

Be Choosy

Only LESCO offers four distinctly different sulfur-coated urea fertilizers. Each available in a variety of analyses.

Choose from our standard formulation, a new intermediate mini-size, the popular ELITE micro-particle products or the new ELITE with iron and manganese bonded to every particle.

All top quality. All designed to provide steady, gradual greening for up to three months.

Order today. Contact your LESCO Sales Representative, visit your local LESCO Service Center or call us toll free.

(800) 321-5325
NATIONWIDE

(800) 362-7413
IN OHIO

Standard-Particle
Sulfur-Coated
Urea Fertilizer

ELITE Micro-Particle
Sulfur-Coated
Urea Fertilizer

ELITE Fertilizer
with Iron
and Manganese

Mini-Particle
Sulfur-Coated
Urea Fertilizer



LESCO, Inc.
20005 Lake Road
Rocky River, Ohio 44116
(216) 333-9250

Circle No. 122 on Reader Inquiry Card

Irrigation products combine efficiency and durability

Toro's Irrigation Division has introduced new irrigation equipment designed to operate systems efficiently. The 570C-12P (pictured), the latest in Toro's 570C Fixed Spray Series, features the company's Conilip™ seal and cap configuration for improved seal and reduced flush action.

With the 570C-12P, the Conilip™ series includes three-, four-, six- and 12-inch pop-up models with 75 different nozzles.

Also, Toro has put a stainless steel sleeve around its 610 gear-driven rotary sprinkler.

The company has also introduced two Custom II series controllers available in either hydraulic or electric with a choice of eight or 12 stations.



They feature a seven-day watering cycle and up to 11 start times per day.

Circle No. 192 on Reader Inquiry Card

Aquatic herbicide in gallon containers

Rodeo aquatic herbicide from Mon-

santo is now available in one-gallon containers. Users can order by telephone for direct delivery.

"This will be very convenient for those who have just a small problem with aquatic weeds in drainage ditches or small retaining ponds," says Monsanto's Sharon Gabel. "It will be especially helpful to owners of small recreational swimming and fishing lakes who are troubled with cattails which have taken over the shoreline."

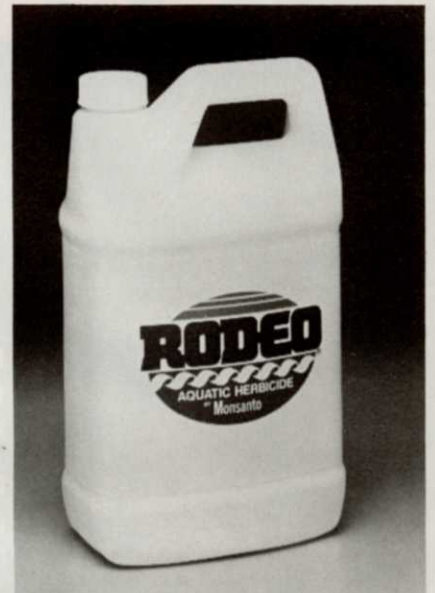

Rodeo is a broad-spectrum aquatic herbicide that provides effective control of more than 160 emerged grasses, brush and broadleaf weeds.

Circle No. 193 on Reader Inquiry Card

Tree transplanter is completely self-contained

The tree transplanter from Mid-Dakota is completely self-contained, can be towed by anything and goes anywhere a garden tractor goes without damaging lawns or underground sprinkler systems.



The size of the rootball can be set exactly for each trunk diameter through 2½ inches, making it useful for potted trees and shrubs. The towa-

continued on page 74

HOLD IT!



STAPLE



PIN

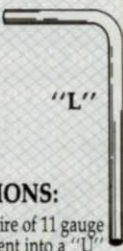

"L"

STANDARD SPECIFICATIONS:

STAPLES: Steel wire of 11 gauge (.120") diameter bent into a "U" shape, flat tops, with 1" between the two parallel legs of 6" standard length.

SOD PINS: Steel rod of 3/16" (.187") minimum diameter, sharp on one end and with a steel washer of 1½" minimum diameter captured on the opposite end.

"L" SHAPE: Steel wire of 9 gauge (.148") diameter, with the standard lengths being 4"x6" 4"x8" and 4"x12". Other Dimensions Available Per Your Specifications.



Mar-Mac staples, sod pins and "L" shapes are made to meet all current geotextile standard installation specifications, and Mar-Mac can also make staples, pins or "L"s to meet any customer specification.

Some of the many applications of the Mar-Mac products are erosion control and foundation stabilization on golf courses, airports, strip mines, and building sites.

Toll Free 1-800-845-6962

MAR-MAC MANUFACTURING CO., INC.
P.O. Box 278, McBee, South Carolina 29101

Circle No. 126 on Reader Inquiry Card



NOW, THE FIRST NAME
IN FUNGICIDES IS
THE LAST WORD
IN CONVENIENCE.

INTRODUCING
NEW CHIPCO®
26019 FLO.

FUNGICIDE

The easy way to stop major
turf diseases for up to
four full weeks.

Thousands of golf course superintendents have discovered one important fact. You just can't beat Chipco 26019 fungicide for controlling turf diseases.

And now you can get all the advantages of Chipco 26019 wettable powder in a convenient flowable formulation. New Chipco 26019 FLO.

Like the wettable powder, new Chipco 26019 FLO offers unsurpassed protection against major turf diseases, including Helminthosporium Leaf Spot and Melting Out, Dollar Spot, Brown Patch, Fusarium Blight, Red Thread, Fusarium Patch, plus Gray and Pink Snow Molds.

Chipco 26019 FLO also delivers the same long-lasting residual control. In fact, both Chipco 26019 formulations protect your turf for up to 28 days.

With Chipco 26019, you also get the added benefits of convenience, no phytotoxicity, pesticide compatibility, low toxicity and no corrosiveness.

Wettable Powder or new FLO, it's easy to see why Chipco 26019 is the Number 1 name in turf disease control.

Rhone-Poulenc Inc., CHIPCO
Department, P.O. Box 125,
Monmouth Junction, NJ 08852.



CHIPCO®
26019

FUNGICIDE

Please read label carefully and use only as directed. CHIPCO® is a registered trademark of Rhone-Poulenc Inc.

Circle No. 140 on Reader Inquiry Card

10 reasons why you should ask for a Continental R-Series engine

High performance, long life design — that's what the Continental R-Series liquid-cooled engines from Teledyne Total Power can offer you.

Take a look at the counter-weighted spheroidal cast iron crankshaft with five main bearings and forged steel connecting rods... right down to the cast iron cylinder block and crankcase, you can depend on the quality to keep up with your

equipment.

Ask for Continental R-Series engines from Teledyne Total Power, with over 5,000 distributors and service centers in over 90 countries ready to serve you. Send for your free "Reasons Why" brochure today: Teledyne Total Power, P.O. Box 181160, Memphis, TN 38181-1160, 901/365-3600, Telex: 462-1058 (ITT)

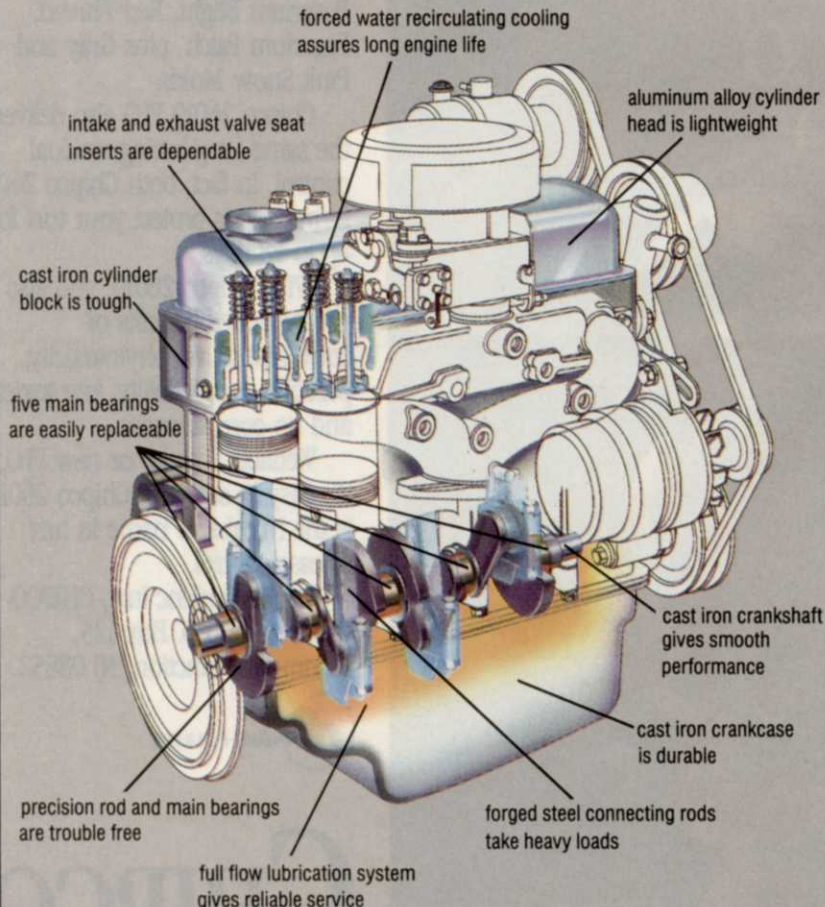

**TELEDYNE
TOTAL POWER**

3409 Democrat Road • Memphis, TN 38118
Call toll-free: 1-800-932-2858

R-11/14

Circle No. 146 on Reader Inquiry Card

PRODUCTS from page 72

ble transplanter is \$4,500, the transplanter for mounting in a bucket or loader is \$1,500.

Circle No. 194 on Reader Inquiry Card

Power saw introduced at Landscape Expo

The Linear Link, a portable power saw from Progressive Power Tools, was unveiled at the Landscape Exposition in Chicago, March 3-5.

The saw leaves a smooth cut on landscape timbers used for building planters, decks, railings and other structures. The saw can cut notches without overcutting, has an eight-inch cutting capacity and cuts angles to 45 degrees.

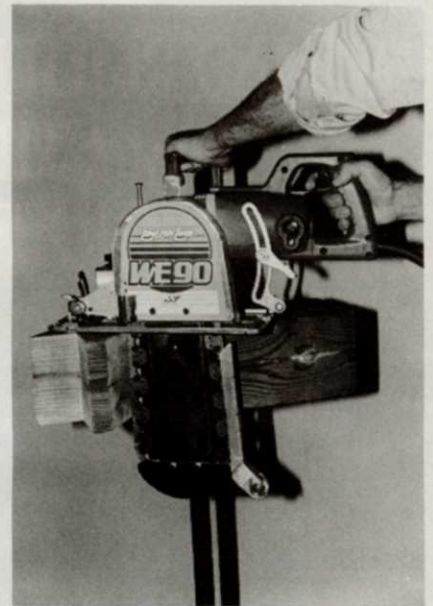

Safety features include a full upper blade guard, a non-removable tip guard and rear pivoting blade guard.

Blue colorant marks path of spray application

Turf Mark, a blue color spray indicator, shows where spray is applied. The temporary colorant is a formulated concentrate that mixes easily with pesticides and fertilizers or other plant growth-regulating chemicals. Amount of colorant concentrate can be varied for more or less color intensity.

The colorant helps eliminate spray overlap, over-application, skips and drift. It can be used in spot spraying or broadcast application. The colorant comes in poly bottles with self-calibrating spouts, in one quart or one gallon sizes.

Circle No. 196 on Reader Inquiry Card

continued on page 76

The Bare Facts

SEED SHIELD VERSUS STRAW.



USCO Landscapes project, Richmond, VA—SEED SHIELD was tested by a professional landscaper against straw in covering grass seed.

Both areas were identically prepared, seeded and subjected to the same growing conditions including a 6 week drought.

But then, after 1 week of identical watering, the SEED SHIELD covered side (left) showed dramatic germination results compared to the straw covered side (right).



Betty Staples, Owner
USCO Landscapes, Richmond, VA

“SEED SHIELD cuts germination time in half.”

“I was skeptical about using SEED SHIELD at first,” admits Betty Staples, a professional Richmond, VA landscaper. “But after using it on several commercial and residential projects since September, I am sold on it.

“On the average, using SEED SHIELD along with proper soil preparation and watering, I’ve been getting over 90% germination

in 4-5 days for fescue. With a straw covering, it generally takes twice as long to get just 60% germination and considerably longer to get full germination.

“SEED SHIELD seems to hold just the right amounts

of heat and moisture. I was able to get excellent fescue germination in October and November despite extreme weather conditions including drought and drastic temperature changes. Plus only one daily watering was needed instead of the usual 3 required with straw.

“It also solved a number of other landscaping problems. I got fewer bare spots. SEED SHIELD virtually eliminated debris from the new grass. It cut down on wash caused by rain. And it kept the birds from eating the seeds.

“I’ve recommended it to homeowners and other landscapers as being very cost-effective in the long run for producing faster, healthier sod quality growth. Plus it can let you seed earlier and later in the season than straw.”

For faster, fuller grass and profit development, talk to A.C.F., Inc. about the unique, new SEED SHIELD fabric.

Distributorships
Available

SEED SHIELD™

A.C.F., Inc.

Distributor for



Manufactured by Amoco Fabrics & Fibers Co. for Atlantic Construction Fabrics, Inc.
10201 Jefferson Davis Hwy., Richmond, VA 23237 • Toll Free 1-800-448-3636. In VA 804-271-0633

Circle No. 101 on Reader Inquiry Card

FAST GREEN COVER UP

with



or with the new



HYDRAULIC MULCHING WITH CELLIN IS EASY, AND FAST, AND ECONOMICAL. SEED, FERTILIZER AND MULCH ARE MIXED INTO A SLURRY AND SPRAYED ONTO THE GROUND — IN ONE EASY STEP.

TACKLING STRAW (OR HAY) MULCHES WITH CELLIN MULCH IS EFFECTIVE, AND FAST, AND ECONOMICAL.

CELLIN MULCHES ARE DARK GREEN, COMPLETELY FREE OF WEED SEEDS AND CONTAIN NO GROWTH INHIBITING FOREIGN MATTER.

CELLIN MULCHES ARE FORMULATED TO MIX READILY WITH WATER AND TO REMAIN EVENLY DISPURSED IN THE SLURRY.

PACKAGED IN 50 lb. HEAVY DUTY POLYETHYLENE BALES — EASY TO HANDLE, STACK AND STORE.

CELLIN
MANUFACTURING INC.
800/336-3074
703/690-1195

Circle No. 104 on Reader Inquiry Card

PRODUCTS from page 74

Water absorber handles 4,000 gal./hr.

The Super Sopper has been used in Australia for more than eight years. It is now available in the United States. The Sopper, available in four sizes, can handle as much as 4,000 gallons per hour (the Whale) for heavy duty



jobs such as fairways or outfields, down to smaller jobs such as greens or tennis courts.

The Sopper works on grass, sand, concrete, asphalt and other surfaces, absorbing one inch of water on each pass. Conversely, it can also be used to wet a surface after an event to help repair damage.

Circle No. 197 on Reader Inquiry Card

Wheel loader performs with power, durability

The Coyote C8 fully articulated loader goes where skid loaders go, handling buckets from 0.75 cubic yards to 1.25 cubic yards through means of a Z-bar linkage with one double-acting lift and one double-acting bucket cylinder.

It is powered by a Duetz four-cycle, two-cylinder air-cooled diesel engine generating 38 hp. Four-wheel drive



can be activated by the operator from the cab. The loaders feature a three-year/3,000-hour full drive train warranty.

Circle No. 198 on Reader Inquiry Card

Even more
It's kid proof



Denser, darker green Manhattan II takes the bruises *for* your athlete

What goes up must come down . . . and that goes double for athletes' knees and elbows.

Improved Manhattan II perennial ryegrass has a built-in cushion developed through genetic improvement. The greater tiller density of Manhattan II takes the punishment athletes dish out, then springs back to retain its great-



looking appearance. All that toughness . . . with improved mowability to boot!

Manhattan II also provides a darker green color than the old standard Manhattan; improved disease resistance, drought and shade tolerance as well as fertilizer savings.

Manhattan II was developed to save on maintenance costs . . . but the *real* saving is on knees and elbows!

"Fall on the leader"
Manhattan II
TURF-TYPE PERENNIAL RYEGRASS

Qualified turf associations can earn cash for turf research by saving Manhattan II blue tags. Contact your dealer for details.



Distributed by

Turf Merchants, Inc.

P.O. Box 1467 • Albany, OR 97321
Outside Oregon 800-421-1735
503/491-3622 TWX 910-997-0733

Turf-Seed, Inc.

P.O. Box 250 • Hubbard, OR 97032
503/981-9571 TWX 510-590-0957

Circle No. 148 on Reader Inquiry Card

CLASSIFIEDS

RATES: \$1.00 per word (minimum charge, \$25). Bold face words or words in all capital letters charged at \$1.25 per word. Boxed or display ads: \$85 per column inch-1x (one inch minimum); \$80-3x; \$75-6x; \$70-12x. Agency commissions will be given only when camera-ready art is provided by agency. For ads using blind box number, add \$5 to total cost of ad. Send ad copy with payment to Dawn Nilsen, LANDSCAPE MANAGEMENT, 1 East First Street, Duluth, MN 55802 or call 218-723-9200.

BOX NUMBER REPLIES: Mail box number replies to: LANDSCAPE MANAGEMENT, Classified Ad Department, 1 East First St., Duluth, MN 55802. Please include box number in address.

BUSINESS OPPORTUNITIES

Outstanding business opportunity available! Very, very fast growing tree, shrub and lawn care company on Long Island for sale by one of New York's leaders in the greens industry. Serving prestigious areas of Suffolk Counties North and South shore. Fully automated working environment. Three truck fleet completely equipped. Terms negotiable. Monday through Friday 9:00 - 5:00. 516-360-3361. 8/87

WANT TO BUY OR SELL a golf course? Exclusively golf course transactions and appraisals. Ask for our catalog. McKay Golf and Country Club Properties, 15485 N. East Street, Lansing, Michigan 48906. Phone (517) 484-7726. TF

Tired of working 12 hours a day for someone else's bottom line? Be your own boss! Earn your own profits! For as little as \$6800 down you can join the LawnCare professionals at ServiceMaster. Call (312) 964-1300 ext. 2242 to receive information on how to get started. 12/87

HELP WANTED

Landscape Maintenance Salesperson position available with Yardmaster, Inc. in Cleveland, Ohio. Excellent compensation plan and benefits. Join Ohio's largest design/build and maintenance firm. Send resume or call **YARDMASTER, INC., 1447 N. RIDGE RD., PAINESVILLE, OH 44077, 216-357-8400.** 10/87

ESTIMATOR SALESPERSON: A diversified, growing, suburban Cleveland landscape firm has an opening for a landscape Estimator/Salesperson for commercial projects. Applicants must have experience in commercial landscape contracting and a college degree in a related field, ability to deal with landscape architects and general contractors needed. We are looking for a highly motivated individual with a proven record to help us grow. If you are qualified for this career opportunity, please send resume, work and salary history to Chagrin Valley Landscaping, P.O. Box 391002, Solon, OH 44139. 8/87

ARBORISTS: ASSISTANT FOREMAN AND FOREMAN positions available. Top pay and benefits including medical plan, paid sick and vacation time, education and year round work. You should be experienced in shade tree and ornamental pruning, landscape planting and spray operations. An excellent chance to work for a top quality company in suburban Boston. **CALL LUEDERS TREE AND LANDSCAPE @ 617-359-4855 OR 617-444-0994.** 8/87

LANDSCAPE MAINTENANCE AND CONSTRUCTION FOREMEN: Suburban Cleveland firm is seeking experienced individuals who can work together with other people. Must be hard working, organized and capable of directing a project from beginning to end. Salary commensurate with experience. Send resume to: P.O. Box 391002, Solon, OH 44139. 8/87

LANDSCAPE MAINTENANCE SUPERVISOR: Expanding landscape management firm seeking individual with supervisory ability and a minimum of two years experience in maintenance and/or installation. An agricultural related background or degree would be beneficial. Send resume with salary requirements to: Maintain Inc., 16008 Boss Gaston, Richmond, TX 77469, Attn: Branch Manager. 8/87

Sales Rep. North Jersey tree expert co. seeks responsible, experienced, sales oriented person. Excellent compensation for right individual. Send resume & salary history to LM Box 423. 8/87

NEED MANAGERS? Need qualified managers to run new or existing operations? Locate key personnel quickly. Call Beecher Smith, Green Industry Resources Corporation (301)253-5787.

CITY ARBORIST

The City of Urbana, Illinois, (pop. 38,000), home of the University of Illinois, and a TREE CITY U.S.A. for 11 consecutive years, seeks to fill an opening for City Arborist. The person who fills this position will be responsible for the administration of the City's tree planting and maintenance program; supervision of divisional staff; administration of the Arbor Division budget, including special funds; and administration of the City's tree ordinance and standards and special projects.

Interested candidates should hold a bachelor's degree with emphasis in forestry, ornamental horticulture, or appropriate biological science and three (3) years of work experience in arbor management.

To apply, please submit resume and introductory letter, salary history and expectations to: Ronald Gremore, Personnel Manager, City of Urbana, 400 South Vine Street, Urbana, Illinois 61801, before September 11, 1987.

(E.O.E.)

LANDSCAPE MAINTENANCE FOREMEN NEEDED: Expanding commercial landscape maintenance firm servicing Dallas/Ft. Worth areas. Knowledge of industry a must. Send resume to: **GROUND TECH INC., 2036 Bedford Road, Bedford, Texas 76021.** 9/87

ASSISTANT TO PRESIDENT: Outstanding opportunity to join and grow with Westchester's fastest growing Tree Care Company. All benefits. Send resume to Ms. Michele Gerards, Sav-A-Tree of Westchester, Inc., P.O. Box 527, Armonk, NY 10504-0527. 8/87

PROJECT MANAGER: Excellent opportunity for career and goal oriented individual to work with a commercial landscape firm in Atlanta, Georgia. Must be experienced in all aspects of landscape construction and willing to assume total responsibility. Good salary, benefits and incentive program. Scapes, Inc. 404-956-7500. 8/87

PO•TEN•TIAL - THAT CAN, BUT HAS NOT YET, COME INTO BEING; POSSIBLE. Established and expanding landscape Management Firm in D/FW area is looking for Account Representatives that are self-motivated & energetic individuals. Training, benefits, salary plus commission. Send resume/work history to John Delin, 2036 Bedford Road, Bedford, Texas 76021. 8/87

ARBORIST SALES POSITION: Outstanding opportunity to join and grow with Westchester's fastest growing Tree Care Company. All benefits. Send resume to Ms. Michele Gerards, Sav-A-Tree of Westchester, Inc., P.O. Box 527, Armonk, NY 10504-0527. 8/87

Gibbs Landscape Company - Landscape and grounds maintenance. High caliber people needed to assist award winning company doing quality work in Atlanta area. Must have good driving record, and transportation. Offer good pay, and benefits. If you are dependable and industrious, send resume: Attn: Mike Sherman, 4111 Burge Road, Smyrna, GA 30080. (404)432-7761. 9/87

TURF AND ORNAMENTAL APPLICATOR MANAGER - Located in the beautiful, horse country of Lexington, KY. The nation's 2nd oldest landscape nursery is looking to expand its pesticide/lawn/care department. Applicants must have experience in all phases of chemical application, record keeping, sales, personnel, customer relations, and department management. We are looking for a self-motivated person to fill this career position. Compensation includes a full set of benefits plus top pay. If qualified, please send resume and salary history to: Hillenmeyer Nurseries, Inc., 2370 Sandersville Road, Lexington, KY 40511, ATTN: Lee Gifford or call 606-255-1091. 8/87

LANDSCAPE MAINTENANCE SUPERVISOR: Scapes, Inc., a commercial landscape firm in Atlanta, Georgia, is seeking an individual who has strong management skills, as well as, extensive landscaping experience and knowledge of plants. Advancement potential — up to Division Manager — makes this position ideal for a goal oriented individual. 404-956-7500. TF

HELP WANTED

Assistant Managers & Foremen

Excellent growth opportunity with Connecticut's largest landscaping firm. Complete Interior and Exterior Construction and Maintenance Departments. Candidates should have an "A.S." or "B.S." in Horticulture or equivalent in experience also two years experience supervising and motivating people. Excellent company benefits. Salary commensurate with experience. Send resume with education, experience, and salary history in confidence to:



Milford

MILFORD LANDSCAPING & MAINTENANCE, INC.

P.O. BOX 2-186
MILFORD, CT 06460
203-878-8748

Fleet Superintendent/Equipment Coordinator to perform maintenance on diesel/gas equipment 80 h.p. to 1 h.p. and coordinate the use of equipment throughout the state of Florida. Please send resume to Quandt-Ayer Enterprises, P.O. Box 271880, Tampa, FL 33688. 8/87

SEND YOUR RESUME IMMEDIATELY! We have open positions for Lawn Care Branch Managers, Nursery Managers, Horticultural, and Landscape/Const. Managers. We computer file your resume and contact you when jobs open in your field or area you desire. Confidential placement from Green Industry Resources Corporation, 25230 Conrad Ct., Damascus, MD 20872, (301)253-5787. 8/87

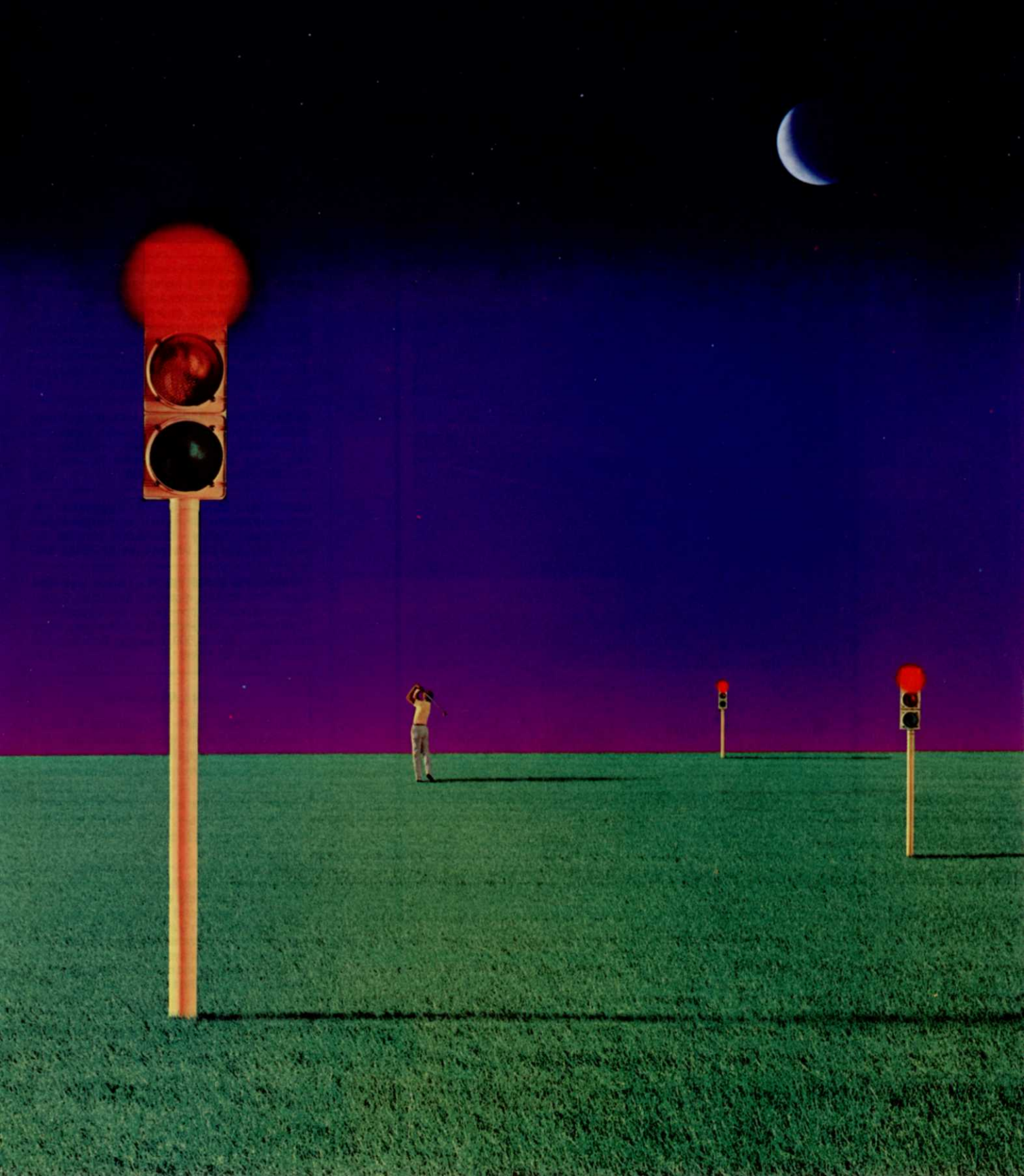

Stops leaf spot for less.

Dyrene 4.

It's the economical new formulation of a proven performer. So now you can keep leaf spot under control. Without your budget getting out of control. DYRENE 4 flowable turf fungicide. The stopper. Mobay Corporation, Specialty Products Group, Box 4913, Kansas City, Mo. 64120



DYRENE is a Reg. TM of Mobay Corporation. 6-2254

Circle No. 128 on Reader Inquiry Card

TURFCO METE-R-MATIC II

TOW-TYPE TOP DRESSER

Top dressing levels existing turf on athletic fields while stimulating growth and improving soil conditions. Repetitive top dressing fills in the low spots and also promotes the decomposition of thatch.



■ Top dress 18 golf greens in under 6 hours

■ Top dress an athletic field in under 2 hours

■ 18.3 cubic feet hopper capacity

■ Top dress at up to 8 miles/hour



■ Spreading width of 60"

■ Ground driven no engine to maintain

TURFCO also manufactures self-propelled and truckster-mounted METE-R-MATIC TOP DRESSERS

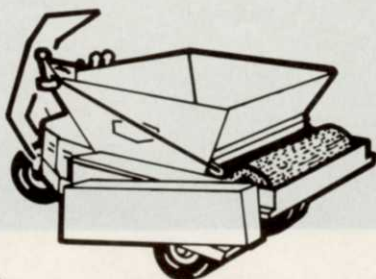

TURFCO MFG., INC.
3456 N. Washington Ave.
Minneapolis, MN 55412-2688

Ph. 612/588-0741
Telex 5106013762

TURFCO

Circle No. 147 on Reader Inquiry Card

HELP WANTED

Lawn Care and Lawn Maintenance Assistant Manager: Leading Horticultural Company since 1929 is seeking qualified applicant who is highly motivated, management oriented and strong in customer sales and service. Excellent growth opportunity and benefits. Salary commensurate with experience and performance. Send resume to: McNaughton's Nurseries, Inc., 351 Kresson Road, Cherry Hill, NJ 08034. 10/87

Established Central Florida landscape contractor has an opening for a highly qualified operations manager for its maintenance division. Ability to schedule, organize, and manage people in a rapidly growing organization. Heavy field experience, and a commitment to quality work required. Opportunity for an aggressive person to be a key member of a top notch team. Excellent salary and benefits. Call: Mr. Singh, 305-831-8101. 8/87

NURSERY MANAGER - Metro-Detroit landscape contracting firm. Horticultural degree, experience in purchasing, inventory control, wholesale nursery. Salary - \$25-45,000, benefits. Resume: P.O. Box 314, Walled Lake, MI 48088. 8/87

LANDSCAPE DESIGN/SALES - Aggressive, self-motivated person. Minimum 2 years experience in design/sales. Salary - \$25-45,000, benefits. Resume: P.O. Box 314, Walled Lake, MI 48088. 8/87

LANDSCAPE SUPERVISOR - Detroit area landscape firm, seeking motivated individual. Experience in residential, commercial landscape plans. Plant material and construction techniques. Benefits, salary - \$25-35,000. Resume: P.O. Box 314, Walled Lake, MI 48088. 8/87

ORKIN LAWN CARE

Orkin Lawn Care is opening 4 new branch locations this summer and is NOW taking applications for experienced Lawn Care Managers and Assistant Managers. Areas include Florida, Texas, North Carolina. Send resume to Gordon Crenshaw, 2170 Piedmont Rd. N.E., Atlanta, Georgia 30324 or call 404-888-2771.

Landscape Architects/Supervisors (project foremen) to join a nationally acclaimed firm looking to expand into its second generation Long Island area supports a high budget landscape industry. Year round employment, company benefits and continuing education available. Experienced and aggressive people send resume to: **GOLDBERG & RODLER, INC.**, 216 East Main Street, Huntington, New York 11743. 10/87

CAREER OPPORTUNITIES: ChemLawn is now accepting applications for the positions of Lawn Specialist in our expanding Florida Markets. Join the Nation's Leader in Lawn Care. Send resume to LM Box 422. TF

HELP WANTED: Landscape, turf and spray foremen, nurserymen and pruners. Experience and/or education necessary to work for our dynamic, quality oriented, large, 40 year established company in the Hamptons on Long Island. Professional wages and benefits, year round, full time positions. Contact: Whitmore-Worsley Inc., P.O. Box 10, Amagansett, NY 11930. (516)267-3756. 9/87

MANAGEMENT: Ever-Green Lawns Corporation, a division of the multi-national Hawley Group, Ltd. is looking for experienced lawn and tree care professionals. Please respond in writing only to Richard D. Niemann, Corporate Recruiter, Ever-Green Lawns Corp., 1390 Charlestown Industrial Drive, St. Charles, MO 63303. TF