



"I have only eighteen concerns when selecting my greensmowers."

*Peter Smith, Superintendent
Shinnecock Hills Golf Club*

"When you're hosting the U.S. Open, the quality of your greens is going to be evaluated by the best golfers in the world and a national television audience. That's why I use only Buntun mowers to maintain my greens here at Shinnecock Hills," says Golf Course Superintendent Peter Smith.

Since he discovered Buntun mowers, Smith has purchased eight greensmowers and two teemowers. Here are some of his comments.

On the tournament:

"For three years before the 1986 Open I mowed my greens at 5/32" with 22" Buntun walk-behinds. For the tournament I mowed at 1/8". The Buntun doesn't have a floating head so I get a true 1/8" cut once I set and lock in the height. With the new Buntun tournament knife I can easily get down to 7/64" without digging into the green."

On Buntun features:

"The powered rotary brush is a great feature. It stands the grass up before it's cut to control grain and

eliminate runners. I use grooved rollers for closer, more accurate cuts and verticut attachments for thatching."

"The solid aluminum drive rollers on the Buntun machines give me firmer greens without compaction. They cut straight, since both rollers are powered, and I've never had a problem with the engines."

On teemowers:

"My tees concern me as much as my greens. With Buntun I get a striped, walk-behind look, plus the efficiency of a 26" mower. After all, those TV cameras focus on the tees almost as much as the greens. They have to be in top condition."

For at least eighteen more good reasons to use Buntun, write or call for our new literature and the name of your Buntun distributor.

BUNTON CO.

P.O. Box 33247
Louisville, KY 40232 USA
Phone 502/966-0550 • Telex 204-340



plex reel mower used primarily for greens and increasingly for mowing close-cut fairways. The 300 greens-mower's strength lies in its unique features, including an 18-hp twin cylinder engine, hydraulic "power" steering, and an improved filtration system. Additional strengths include the use of only the finest components and dedication to quality and service support. And by marketing direct to the end user, Lesco is able to offer the product at a competitive price.

Locke Manufacturing Inc.

● Model No. 6, a 70-inch triplex lawn mower with five blades used in commercial applications. Model No. 10, which is the same as a No. 6, but has a reverse transmission. This mower has been Locke's backbone in sales for more than 55 years. The average life is 20-25 years, an excellent value the customer enjoys.

Mathews Company

● M-C Lawn Genie flail pickup mower offers increased safety for both the operator and bystanders. It is used in a multitude of applications for homeowners, estates, parks, schools, municipalities, golf courses, and professional lawn care operators. It has consistently produced satisfactory growth not only in domestic sales, but

also in foreign sales since its development some 16 years ago.

Middlesworth Eng. & Mfg.

● C40 rotary riding mower with 40-inch cut, is the size mower which fits more people's needs and requirements.

● C44F flail riding mower with 44-inch cut is designed for lawn care and is safer than rotaries.

National Mower Co.

● 84-inch National triplex mower. It exemplifies basic simplicity and rugged construction. It has sold for 60 years.

Ransomes Inc.

● 21-inch heavy duty rotary mower.
● Mid-size mowers (34- to 54-inches). Both types of mowers are used in the landscape industry. They are of heavy duty quality designed specifically for commercial use. Their superior quality has withstood the test of time.

Scag Power Equipment

● SW48-13K, a 48-inch belt-driven walk-behind. Scag introduced it in April and it has gone "hog wild" ever since. The SW48-13K is maneuverable and price competitive.

● ST18B, 61-inch rider used for large capacity cutting areas. Offers maneuverability, high productivity, and an exceptionally good cut.

Sensation, Division of Gilson Bros. Co.

● Sensation walk-behind mowers. These are heavy duty commercial mowers used extensively by lawn care professionals for small areas and trimming after larger riding mowers. Heavy cast Sensation decks are the standard designed for the commercial lawn care industry. The strength and reliability offered makes the mowers well-suited for the professional with reliable, dependable service.

Simplicity

● New Sunstar Series Garden Tractors feature shaft drive to 42-, 48-, and 60-inch mowers, state-of-the-art electronics, two range transaxle, and 18- to 20-hp engines. They come with a large variety of attachments and accessories such as front-end loaders, tiller plows, snowthrowers, dozer blades, and many other work saving devices.

Snapper Power Equipment

● Rear-engine riding mowers.
● Lawn tractors.
● Commercial walk mowers. All three lines are readily accepted by commercial users.

Turner International Ltd.

● Turner Hydramower, a rear-mounted boom mower reaching 17-, 19-or 25-ft., to the left and right hand



The Turner rear-mounted boom mower.

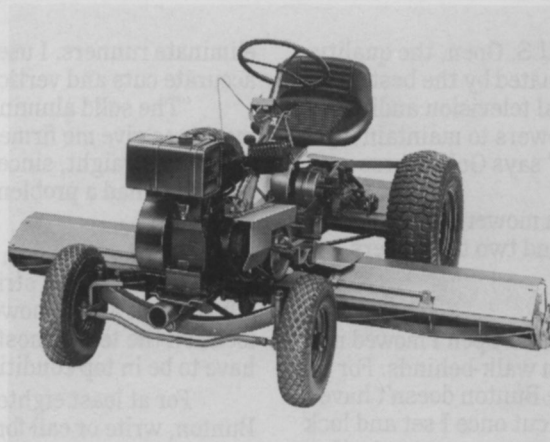

National Mower's 84-inch triplex mower.



The Exmark 48-inch commercial mower.



The Ford lawn and garden tractor, model No. LGT18H.



Simplicity's 18-hp SunStar series garden tractor.



Woods' tractor-powered grass mower.



Frank J. McDonald, Director of Marketing
Cushman Division, Outboard Marine Corporation
Lincoln, Nebraska

CUSHMAN®

"Few things in life last as long and work as hard to make your job more productive and cost efficient."

Frank J. McDonald

An investment in Cushman® turf vehicles and attachments is an investment in a true turf care "working system".

Team up the Cushman Turf-Truckster™ vehicle with one or more of a half-dozen specialized turf care attachments, and you can aerate large or small areas, haul equipment and materials, dump sand, spray, seed or top dress. And, switch from one job to another quickly with the Cushman exclusive "pin-disconnect" system.

The Cushman Turf-Truckster™ vehicle offers plenty of power with the OMC-built 22-hp engine. Choice of 3-wheel or 4-wheel models. And a ground-speed governor control for uniform application over uneven terrain. The Turf-Truckster also rides over fine turf areas without damage to the turf.

No single turf vehicle lets you accomplish so much day after day, year after year.

For more information, and a free full line brochure write:

CUSHMAN®
Frank McDonald, Director
of Marketing, OMC Lincoln
P.O. Box 82409, 5302 Cushman,
Lincoln, NE 68501 or call toll-
free: 1-800-228-4444.

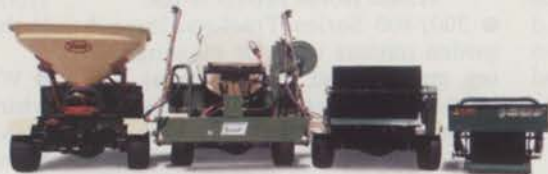

"OUR REPUTATION IS BUILT TO LAST"

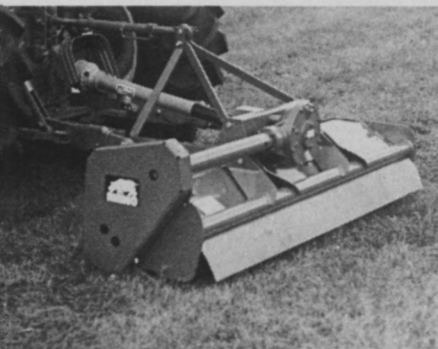

The Alamo Group's Rhino flail mower.

Scag's mid-size walk-behind mower.

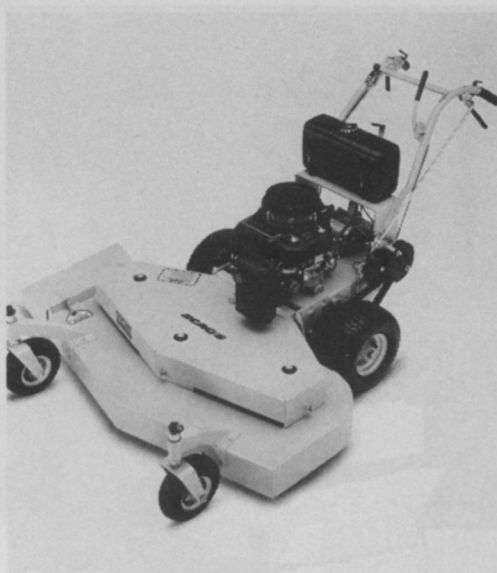

The Bunton 36-inch rotary mower.



Yazoo's Eagle II, a 42-inch, front-cut mower.



Excel's Hustler model No. 340 72-inch out-front rotary mower.



Dandl's Industrial mower.

side of the tractor, hydraulically swinging similar to a backhoe, used for heavy mowing of trees, brush, and grass. The mower's unique design dramatically reduces "deadheading" time spent reversing or travelling back to make a second cut. The mower can be completely removed or fitted within 10 minutes.

Vrismo Manufacturing, Inc.

● **Mighty Max**, front-mounted flail for John Deere, Toro, Hustler, Ransomes, Turf Blazer, and Cushman. It can be used for mowing, thatching, and breaking up aeration cores. Jacobsen offers the only other front-mounted flail. Rotaries cannot be used for thatching and breaking up cores.

Walker Mfg. Company

● **Walker Mower M36-42 or C36-54** is a mid-size (36-inch or 42-inch) commercial grade riding mower used for

mowing and trimming small to medium size landscaped turf areas where maneuverability and grass catching are required for efficient performance of the job. The requirement for a mid-size mower is an emerging segment of the commercial turf care business due to a trend towards use of more small green areas around offices, condominiums, resorts, and the trend towards more residential commercial mowing.

Wheel Horse Products Inc.

● **300/400 Series Tractors**, lawn & garden tractors used for mowing, tilling, grading, and snow removal. The tractors have been the strength of Wheel Horse with their durability and dependability. The cast iron transaxle and angle iron frame give years of dependable service even under the day to day stress of heavy duty applications.

● **700 Series Mowing Machines**, commercial mowers for mowing. A new addition to this product lineup, the 700 Series Commercial Mowing Machines. Its speed combined with zero turning radius maneuverability, make it one of the most efficient/cost saving buys on the market.

Woods, Division of Hesston

● **Rotary, tractor-powered grass mowers** with a cutting swath ranging from 3.5 to 20 ft. The product is Woods' strength based on strong sales in the turf market.

Yazoo Manufacturing

● **Walk-behind Big Wheel mowers** which have been manufactured since 1945.

● **Industrial three-wheel front-cut tractors.**

● **Consumer riders.** The three products constitute 90 percent of sales. **WT&T**

INTRODUCING SCAG'S FULL LINE OF COST CUTTERS.

Scag offers a full line of money-saving, low-maintenance commercial riders and walkers tough enough to handle all your jobs. Not only do Scag mowers cost up to 25% less than comparable models, their easy, self-service design allows for on-site tire changes, replacement of spindle bearings and other repairs at a fraction of the usual time and expense.

What's more, when you save with Scag you don't sacrifice performance because Scag's machines cut up to 30% faster than competi-

tive brands. And, Scag mowers are built from the highest quality parts and materials, like over-size cast iron pulleys, heavy-duty spindle and rugged pneumatic caster wheels. So, they'll outlast as well as outperform ordinary mowers.

Boost your bottom line with Scag's heavy-duty riders and walkers from 8- to 18-HP models with 32 to 61 inch cutting widths. See for yourself why no mower is easier to use than Scag.

W226 N900 Eastmound Drive
Waukesha, WI 53186
Phone: (414) 544-4090

SCAG

POWER EQUIPMENT

IT SIMPLY COSTS LESS. AND CUTS MORE.

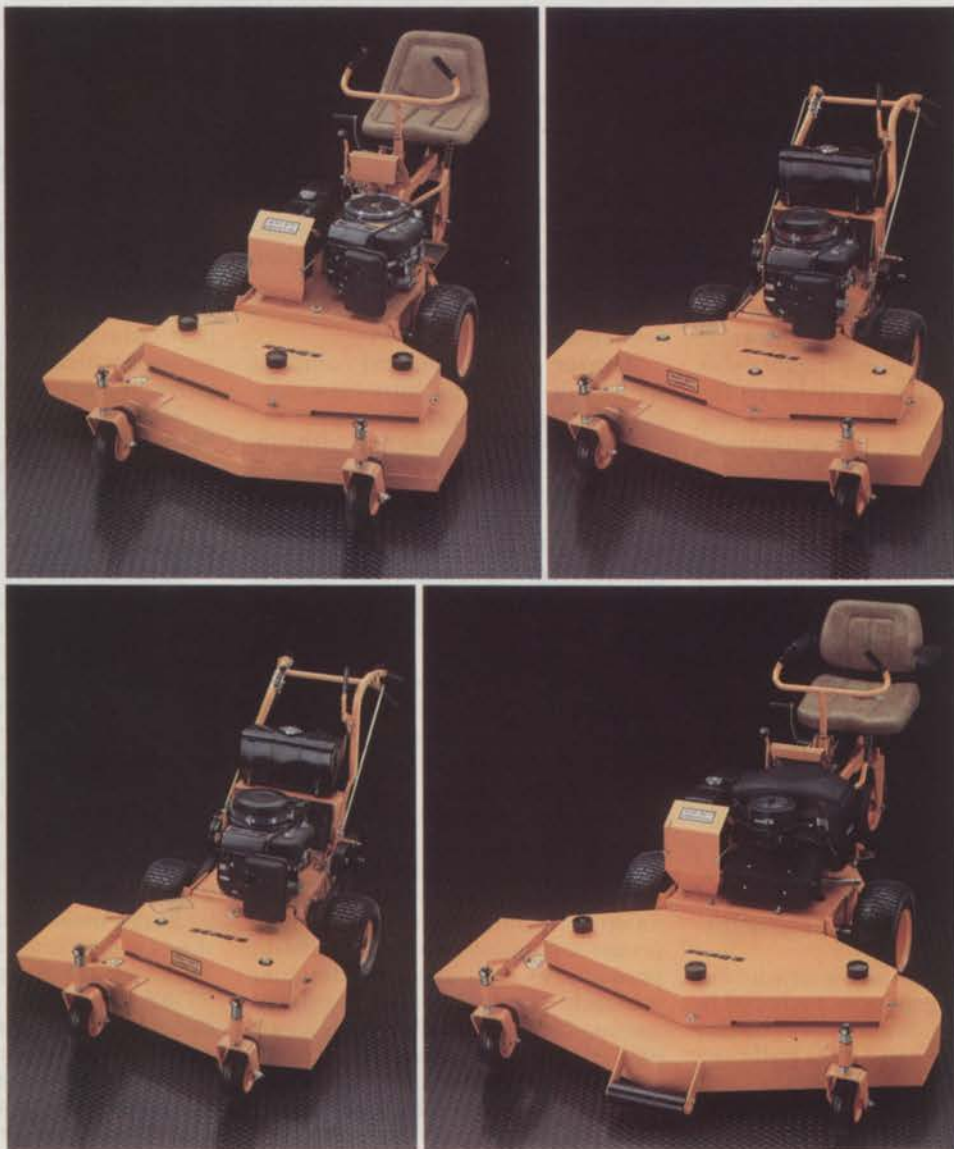

INTO THE FUTURE

Here's what to expect from major mower manufacturers in the future.

Alamo Group is looking at hydraulically powered mowers which would cut down on the wear of the mower, making the upkeep cost lower. The company also is investigating belly-mount units which would fit underneath a tractor and self-powered small mowers which would hook behind an all-terrain or recreational vehicle and be ideal for smaller mowing areas.

Ariens will broaden the WBLM line with more models.

Bomford & Evershed is hard at work building "better and cheaper flail mowers."

Brouwer will market two new 5-gang tractor mid-mounted mowers in 1987.

Bunton has just introduced a thatcher attachment for the rotary mowers, which allows the operator to dethatch. Also, a 12.5-hp Kawasaki engine or an 11-hp overhead valve Honda engine will be available for the rotary mowers. Within the next few months, Bunton will start marketing a triplex greensmower.

Cushman Ryan will offer a wider range of attachments for the commercial mowing market including thatcher attachments, snow and dozer blade, leaf blower, reel mower attachment, flail mowers, aerator attachment, and additional size decks to appeal to all potential users.

Cushman's newest product on the market is the Model 807 Cushman Front Line Diesel with 3-cylinder, 21.5-hp Kubota engine which features a 4-wheel tractor standard, extra wide tires, and power steering.

Dandl Manufacturing has plans for a new reel with both coarse and fine cut knives for the Expando and Industrial mowers.

Deere has introduced a new line of 12 golf and turf products. Included in that line will be 3- and 5-reel tractor mounted and 3- and 5-reel pull-type mowers.

Excel "feels good" with where the product line is right now. They are,

however, looking at additional engine options and attachments which would make the tractors more flexible. The availability of new cutting widths is another possibility for Excel in the future.

Ford Tractor plans to redesign "certain models." Available to the public in the spring of 1987 will be a new diesel-powered garden tractor mower.

Grasshopper is completing the conversion to a new powder-coated paint system. This state-of-the-art process gives an unmatched appearance as well as long-lived durability. Also in the plans is a water-cooled, gas engine model.

Gravely plans to market a new 36-insert multi-mode mower for their 5000 series line (mower has side discharge, rear discharge, and grass collection all in one).

Grazer will implement complete hydraulic drive and introduce commercial walk-behind mowers.

Heckendorn is working with liquid-cooled gas and diesel engines, as well as hydrostatic drives for its original line of mowers. The new line will offer a deck which allows the user to tailor it to fit his needs with respect to size and capability. Options such as a snow thrower and rotary broom also will be available.

Ingersoll Equipment Co., Inc. has released five hydraulically powered attachments in the last three years and is continually striving to add to the versatility of the only hydraulic drive tractor manufactured for lawn and garden use.

Jacobsen maintains a constant, strong engineering research and development and product refinement program: improvements to existing products, as well as newly-designed products are introduced regularly. Among Jacobsen's new products are new triplex mowers and a hydraulic drive 5-gang tow-behind reel mower.

Kinco Manufacturing is getting away from castings and stampings and

looking to forgings in some critical areas to ensure the strength and longevity of products like a new walk-behind front-throw reel mower.

Kubota plans to introduce a 72-inch mower deck and 48-inch mower deck models. Also in the works is a radio control mower with all four wheel steering.

Lesco has introduced the "500" Greensmower, which will be available next spring. The "500" uses the basic design of the "300" with two cutting units added. This gives a 100-inch cutting width and offers the finest cut available for fairway mowing. An out-front rotary and a line of walk-behind rotaries will be available within two years.

Locke doesn't plan modifications of existing products, but will introduce two new products: an 18-inch rotary trimmer for commercial use only and a 70-inch triplex hydrostatic model.

Mathews Co. will broaden its established lines with more models, particularly flail-type mowers and mowers which reduce time and manpower requirements.

Middlesworth Engineering & Manufacturing is designing a 54-inch mower for a line that already runs from 40- to 72-inch cut and adding a grass catcher to the C40R rotary riding mower.

National Mower says changes in its mowers are "always under study." They will introduce a 76-inch triplex to the market in '87.

Ransomes will make modifications to improve the user's "down time" and cost of operations. New products include: 61-inch riding rotary with several engine options (low cost) for the landscape industry; narrow transport 71-inch triplex for golf course and municipality use; and a triplex greensmower for golf course use.

Scag Power Equipment will offer the new engine options of a Kohler 18-hp Kawasaki 17-hp engine for their ST18B rider. They also plan to introduce 12-hp brakes on the mid-size walk-behinds and riders.

Sensation, Division of Gilson Bros. has plans for Honda engine options on 21-inch push mowers at 4- and 5.5-hp,

BROUWER MOWERS



7-GANG FAIRWAY
HYD. LIFT MOWER

- Quality
- Reliability
- Service

tournament tough . . . market proven

THE golf course mower designed specifically to give the precision quality cut that is demanded by the top superintendents. A golf course reputation can be made or lost by word-of-mouth, make sure that the story about your fairways is nothing but praise, by grooming with a Brouwer fairway mower. Check the specifications and the long list of outstanding features that include: Unique floating head design that allows the reels to follow the rolling contours; The special design that permits mowing on slopes without side-slip; The proven mechanical drive, requires less H.P. and fuel and reduces weight for minimum compaction; Front and rear rollers and anti-skid shoes reduce scalping; A high strength structural steel frame for extra durability and lightness . . . These features and many more, plus important options, add up to a superb mower that will outperform others through any conditions cut after cut, season after season.



BROUWER TRIPLEX-376

Triplex-376 . . . Quality in one word. Proving to be a workhorse on the course, when mowing a "Tee" area or around a green which requires a more precise cut, in wet or dry, heavy or light conditions. Superior features include: Dynamically balanced reels; Fine tuned reel to bedknife setting; Free-floating reels with anti-scalp rollers; Foot operated differential lock, and many more. Coupled to Brouwers enviable reputation for after-sales-service, second to none the Triplex-376 will make your buying decision an easy one.

Greensmower . . . from Brouwer for a superb "Tournament Quality" finish cut-after-cut, green after green. The growing reputation earned the hard way . . . by proven performance. This is no idle boast, the machine speaks for itself with outstanding features like: Special hardened alloy steel bedknife; Bearing mounted gears in the traction and reel drive; 1/8in. to 1-3/16in. height of cut; Self pre-load taper bearings, and so on . . . Don't compromise and miss the "Finest Cut" put your greens in tournament day shape, every day . . .



BROUWER GREENSMOWER

BROUWER
TURF EQUIPMENT LIMITED

7320 Haggerty Rd./Canton, MI. 48187 Telephone (313) 459-3700

Woodbine Avenue/Keswick, Ontario, Canada L4P 3E9 Telex 065-24161 Telephone: (416) 476-4311

10 reasons why you should ask for a Continental R-Series engine

High performance, long life design — that's what the Continental R-Series liquid-cooled engines from Teledyne Total Power can offer you.

Take a look at the counter-weighted spheroidal cast iron crankshaft with five main bearings and forged steel connecting rods... right down to the cast iron cylinder block and crankcase, you can depend on the quality to keep up with your

equipment.

Ask for Continental R-Series engines from Teledyne Total Power, with over 5,000 distributors and service centers in over 90 countries ready to serve you. Send for your free "Reasons Why" brochure today: Teledyne Total Power, P.O. Box 181160, Memphis, TN 38181-1160, 901/365-3600, Telex: 462-1058 (ITT)

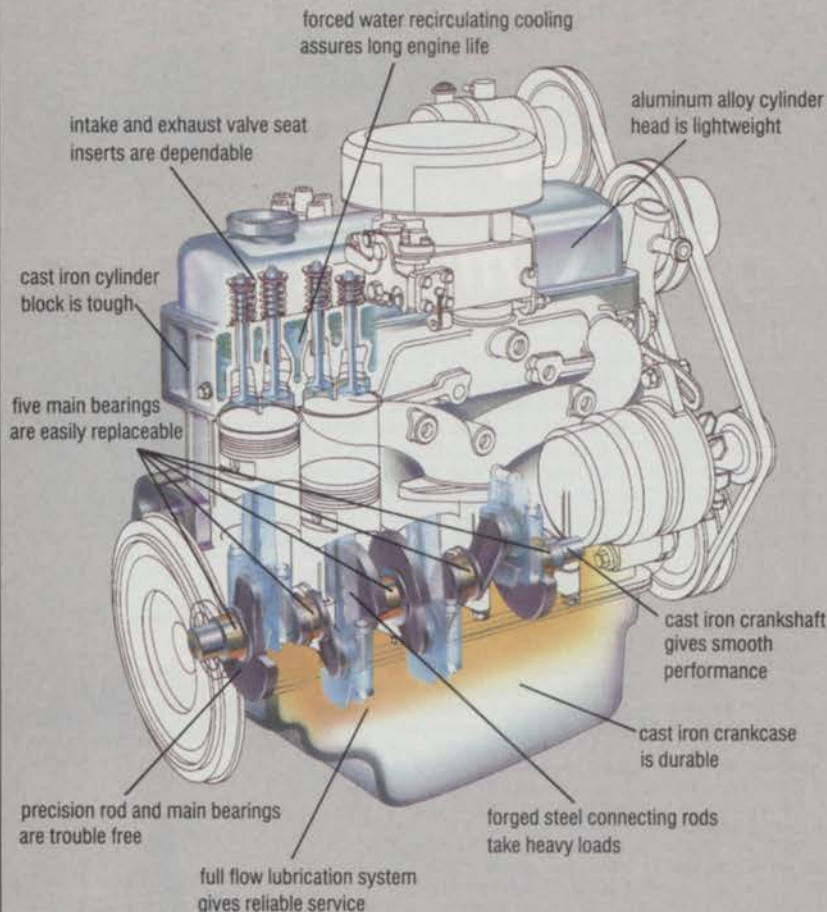

 **TELEDYNE
TOTAL POWER**

3409 Democrat Road • Memphis, TN 38118
Call toll-free: 1-800-932-2858

R-11/14

for two riding mowers with out-front 61-inch and 48-inch cutting decks, three-wheeled configuration, and good maneuverability.

Simplicity promises larger mowing decks for both belly-mount and front-mount mowers along with lower cost and better performing grass collection systems.

Snapper will introduce new models designed for the commercial market, including walk-behinds.

Toro has just introduced a commercial 112-inch walk power mower. It is the fourth model in the company's

Snapper will introduce new models designed for the commercial market, including walk-behinds.

line of mid-size commercial rotary mowers. The mower features a powerful 4-cycle, 12.5 hp Kawasaki engine, making it ideal for heavy cutting situations. It is compatible with Toro's three floating decks (36, 44, and 52 inches).

Turner International Ltd. is constantly evaluating new methods and modifications which will increase output, with safety being the highest priority.

Vrismo will introduce a complete line of updated three-point flails for the turf market plus a new flail knife for a finer cut.

Walker plans to introduce a 16-hp model "C" with long life drive train components. The company will continue to refine the existing model, particularly in boosting performance of the grass handling system.

Wheel Horse will introduce a commercial or extra heavy duty garden tractor with a "beefed up" mowing deck plus a commercial rear engine rider.

Woods, Division of Hesston has an ongoing program for improving existing mower products in performance, safety, and cost competitiveness. The company has no plans at the moment for new mower products.

Yazoo is constantly updating its mowers particularly with safety features and improved appearance. They have introduced two new 42-inch front-cut mowers, the Eagle I for consumer use and the Eagle II for commercial use. Both mowers have hydrostatic drive. **WT&T**

Any way you look at it,



the new Supreme Romanazzi truck bodies give you the best of all worlds.

Supreme Corporation has teamed up with Romanazzi of Italy to produce two tough new truck bodies – a unique three-way dump and a rugged platform. Both bodies combine the advantages of European styling and technology with Supreme's assembly and service expertise.

The Three-Way Dump Body

Offering the convenience and versatility of dumping from the back or either side, the three-way dump body adds a new dimension to the domestic trucking industry. That's not all. With fold-down sideboards and four-way tailgate, a side-locking system and 12-ton hoist capacity, this three-way dump body can handle the toughest assignments in the tightest quarters.

The Supreme-Romanazzi Platform Body

Other trucks may talk quality, but no other body delivers like the new Supreme Romanazzi fixed platform truck. Engineered for stylish performance, this platform body features anodized extruded aluminum sideboards and stainless steel underframe for durability and performance in the harshest conditions.

Any way you look at it, you can't buy better truck bodies on either side of the Atlantic. These bodies are the best of all worlds. And they're only available through Supreme Corporation. Call us today for more information.

16500 CR 38, P.O. Box 463, Goshen, IN 46526
(219) 642-4888

19 & 41 Bypass South, P.O. Box 939, Griffin, GA 30224
(404) 228-6742

Supreme Corporation of Texas, 1910 N. Britain Rd., Irving, TX 75061
Metro 445-0414, (214) 438-4012

Supreme Truck Bodies of California, 13489 Slover Ave., Fontana, CA 92335
(714) 822-0753



When it comes to truck bodies, our name is Supreme



Fall
With A