

SNOW & ICE GUIDE > PLANET'S EXECUTIVE FORUM
TOURING THE CALIFORNIA SPRING TRIALS

Landscaping Management

*The preferred resource
for large contractors*

THE **BIG** **GIVE**

Landscapers across the country lend communities their time and talents.



THE ALL-NEW RAM HEAVY DUTY.
6.7L CUMMINS® TURBO DIESEL.
MOTOR TREND'S 2010 TRUCK OF THE YEAR.*



APPARENTLY, FOLKS WHO
WORK THE LAND FOR A
LIVING PLAN ON DOING SO
FOR A WHILE LONGER.



RAM



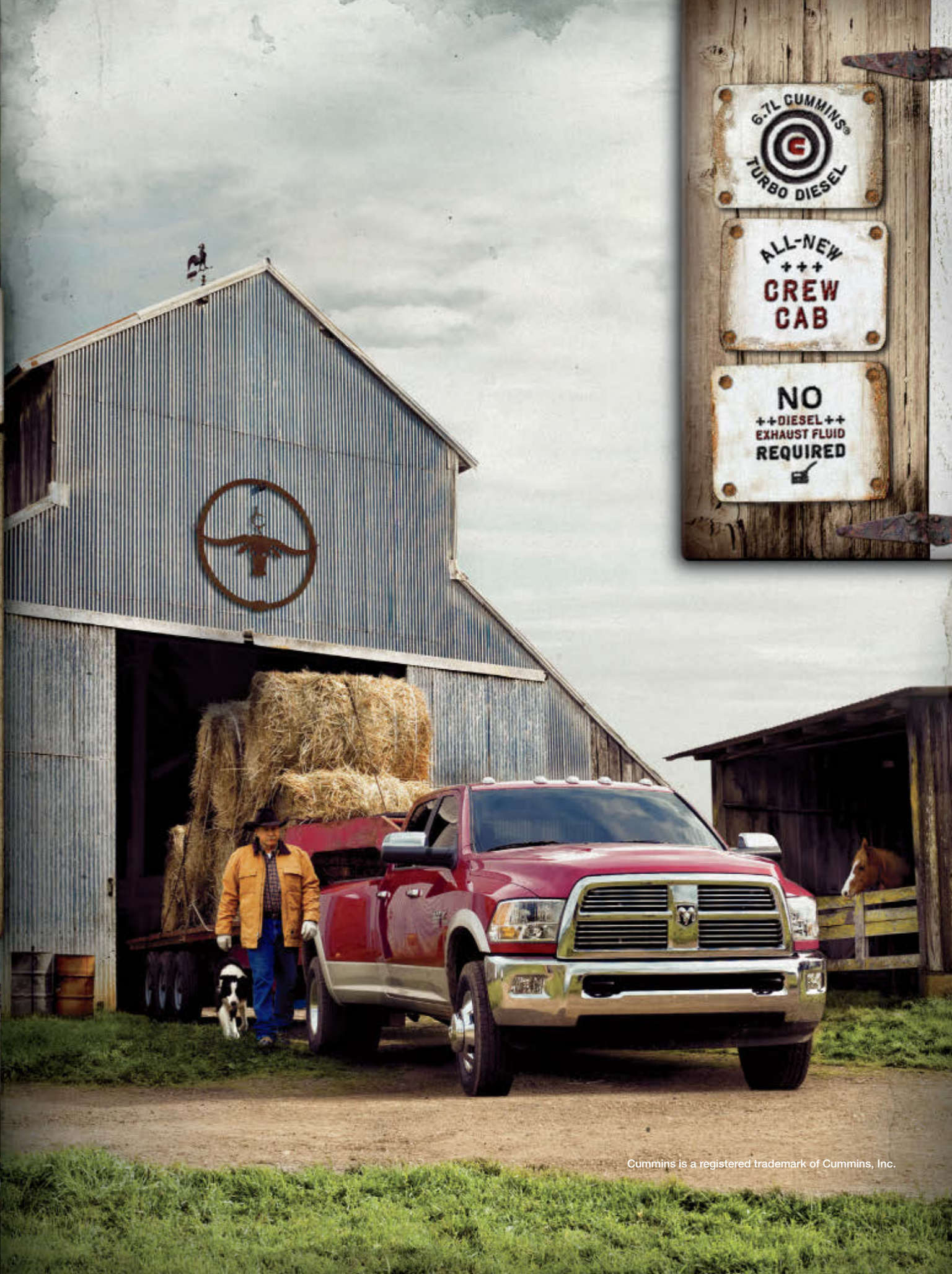

6.7L CUMMINS®
C
TURBO DIESEL

ALL-NEW
+++
**CREW
CAB**

NO
++DIESEL++
EXHAUST FLUID
REQUIRED

CONTENTS »

MAY 2010
VOL 49, ISSUE 5



FEATURES

8 The big give (B) (D/B) (I) (LC) (M)

Landscapers across the country lend communities their time and talents. BY NICOLE WISNIEWSKI, RON HALL AND DANIEL G. JACOBS

60 Executive Forum (B)

PLANET's annual Executive Forum explain it's a sustainable world; we're just living in it. BY DANIEL G. JACOBS

LM MARKET MATCH We've made your life a little easier by supplying icons that direct you to stories targeting your core business.

B – Business, D/B – Design/Build, I – Irrigation, LC – Lawn Care, M – Maintenance

SPECIAL SECTION

39

SNOW + ICE GUIDE

When salt supplies dried up, one contractor tried something different.



DEPARTMENTS

30 **LM Reports** Insecticides; alternative fuel; drip irrigation



30

34 **Lawn Care Pro** John Gibson, Swingle Lawn, Tree & Landscape Care, Denver, CO BY RON HALL



36 **Weed Watch** Annual lespedeza; kyllinga

52 **A Cut Above** Cleary Bros. Landscape, Danville, CA BY DANIEL G. JACOBS

ON THE COVER
Photo by Ron Hall

COLUMNS

4 **First Cut**
BY NICOLE WISNIEWSKI

6 **The Hall Mark**
BY RON HALL

28 **The Benchmark**
BY KEVIN KEHOE

38 **Best Practices**
BY BRUCE WILSON

54 **Info Tech**
BY TYLER WHITAKER

64 **Jacobs' Journal**
BY DANIEL G. JACOBS

IN EVERY ISSUE

62 Classifieds 63 Resources

SPECIAL SECTION

57 **LIVESCAPES**
The California spring trials showed off new varieties and plant trends.



Landscape Management

OUR MISSION: *Landscape Management* — the leading information resource for large, successful lawn care, landscape maintenance, design/build and irrigation professionals — empowers Green Industry professionals to learn and grow from their peers and our exclusive business intelligence. Serving as the industry conscience, we not only report on but also help shape news, views, trends and solutions.



THINKING ABOUT BECOMING A BUSINESS OWNER?

We can help.
We start with you. We stay with you.

Our Franchise Support Team has over 260 years of combined commercial landscape industry experience to assist you with business and industry knowledge.



INVEST IN YOUR FUTURE

BECOME A
FRANCHISE OWNER WITH
U.S. LAWNS

**YOUR
SUCCESS**
is everything to
US



NATIONAL STRENGTH
LOCAL COMMITMENT

1-866-781-4875
franchise@uslawns.net
www.uslawns.com/franchise



FIRSTCUT

NICOLE WISNIEWSKI EDITOR-IN-CHIEF

Contact Nicole at 216/706-3735 or via email nwisniewski@questex.com.

Give a little, get a little

My neighbor, Sean, is one of the most giving people I know. I live in the Cleveland snow belt, and we had some serious accumulation early this year. One morning, just as I was putting on layers of warm clothes and boots and grabbing the snow shovel, he walked his snowblower over to clear my driveway. He saved our backs more than a few times this winter.

In the spring, he is usually the first one to mow his lawn ... and the common areas on our street ... and some of the neighbors' yards. He cruises around on his mower, and before we've even had our first cup of coffee, he's done. "I enjoy it," he says, and leaves it at that.

Sean's giving attitude inspires others on the street. After one particularly bad winter storm, he started clearing neighbors' driveways before many made it home from work. Once they got home, at least four other neighbors joined in. Before long, the impromptu crew had every driveway on the street cleared.

My husband and I tend to feel guilty after these generous acts. We always want to reciprocate. But, most of the time, Sean refuses to let us.

So I tend to talk about him ... a lot. He owns a window and door installation business, and I recommend him ... a lot. His regular unselfish acts speak volumes about his character and, in my opinion, his work ethic.

One person doing something for someone else is great. But an entire industry providing needed services across the country is extraordinary.

On April 22 – Earth Day – more than 3,000 Green Industry professionals put a hold on regular business to donate their services to various community projects in 38 states across the U.S. and Canada during the Professional Landcare Network's 2nd annual Day of Service. *Landscape Management's* Ron Hall, Dan Jacobs and myself traveled to Ohio, Colorado and Connecticut, respectively, to join various landscape teams in their efforts.

For each of us, it was a special experience:

- ▶ Because of a lack of funds and ongoing vandalism at Tarlton, OH's Cross Mound Park, the entrance gate remains closed to visitors. But Ron witnessed its potential reopening because of Mirrorscapes' service.
- ▶ After hearing about Riverside Cemetery's years of

water challenges, Dan watched industry efforts pick up the spirits of cemetery overseers and give new, more sustainable life to the 134-year-old grounds.

▶ And I witnessed the New Milford, CT-based YardApes' crew give all of their effort — without earning a penny — to benefit the community's children.

These events gave back to us in more ways than one. Now it's our turn. In this issue, we showcase these teams' distinctive projects and highlight what it did for them, both personally and professionally.

Who says one good deed doesn't lead to another?

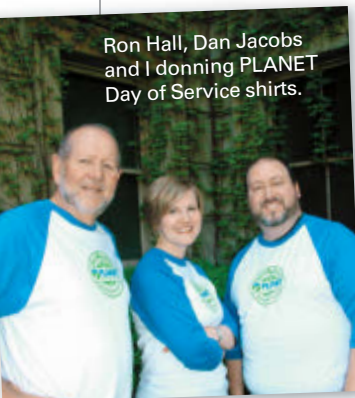

Ron Hall, Dan Jacobs and I donning PLANET Day of Service shirts.

Landscape Management

CLEVELAND HEADQUARTERS
600 SUPERIOR AVE. EAST SUITE 1100
CLEVELAND OH 44114 800/669-1668

EDITORIAL STAFF

Editorial Director Marty Whitford 216/706-3766 | mwhitford@questex.com

Editor-in-Chief Nicole Wisniewski 216/706-3735 | nwisniewski@questex.com

Editor-at-Large Ron Hall 216/706-3739 | rhall@questex.com

Managing Editor Daniel G. Jacobs 216/706-3754 | djacobs@questex.com

Technical Editor Pete Grasso 216/706-3775 | pgrasso@questex.com

Executive Editor Larry Aylward 216/706-3737 | lailward@questex.com

Contributing Editor Heather Gooch 330/723-3539 | hgooch@questex.com

Art Director Carrie Parkhill 216/706-3780 | cparkhill@questex.com

ADVERTISING STAFF

Publisher Patrick Roberts
216/706-3736 Fax: 216/706-3712 | proberts@questex.com

Northern National Sales Manager Dave Huisman
732/493-4951 Fax: 732/493-4951 | dhuisman@questex.com

Southern National Sales Manager Jason DeSarle
216/706-3758 Fax: 216/706-3712 | jdesarle@questex.com

Business Development Manager Ric Abernethy
216/706-3723 Fax: 216/706-3712 | rabernehy@questex.com

Account Executive Classifieds Kelli Velasquez
216/706-3767 Fax: 216/706-3712 | kvelasquez@questex.com

BUSINESS STAFF

Vice President Kevin Stoltman 216/706-3740 | kstoltman@questex.com

Administrative Coordinator Petra Turko 216/706-3768 | pturko@questex.com

Production Manager Amber Terch 218/279-8835 | aterch@questex.com

Production Director Jamie Kleist 218/279-8855 | jkleist@questex.com

Audience Development Manager Antoinette Sanchez-Perkins
216/706-3750 | asanchez-perkins@questex.com

Assistant Audience Development Manager Carol Hatcher
216/706-3785 | chatcher@questex.com

MARKETING/MAGAZINE SERVICES

Reprints landscapemanagement@theygsgroup.com | 800/290-5460 x100

Ilene Schwartz Circulation List Rental 216/371-1667

Customer Services Subscriber/Customer Service
landscapemanagement@halldata.com | 866/344-1315; 847/763-9594 if outside the U.S.

Paul Semple International Licensing
714/513-8614 Fax: 714/513-8845 | psemple@questex.com

For current single copy, back issues, or CD-ROM, call 866/344-1315; 847/763-9594 if outside the U.S.

QUESTEX MEDIA CORPORATE OFFICERS

President & Chief Executive Officer Kerry C. Gumas

Executive Vice President & Chief Financial Officer Tom Caridi

Executive Vice President Antony D'Avino

Executive Vice President Gideon Dean

At least there's one place where the left
and the right work in harmony.

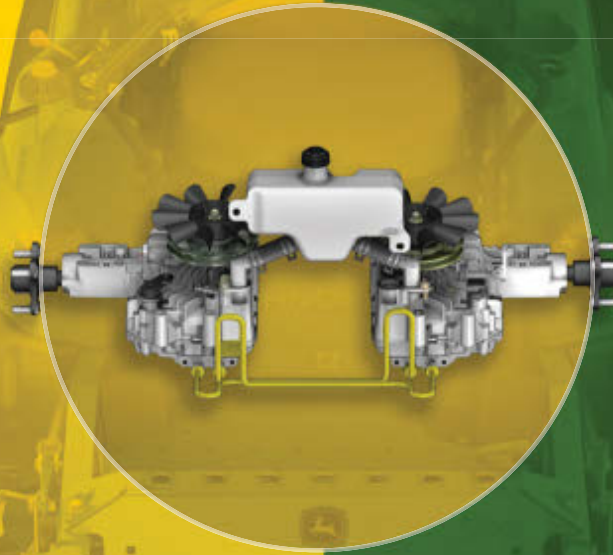

0%
APR
FOR 24
MONTHS

Our unique, all integrated ground drive system.

Even in our divided world, there's still a place where two sides work perfectly together: on our new ZTrak PRO 900. Thanks to an integrated ground drive transmission with piston pumps and piston wheel pumps, the Z900 has lightning-quick responsiveness and tremendous traction. And with our unique cross-porting system, cool hydraulic fluid routes to the hydraulic pump doing the most work. For a demo, contact your local John Deere dealer. And don't forget to ask about the Work It For A Week Guarantee.

Accept nothing less.

Offer valid 2 March 2010 through 2 August 2010. Subject to approved credit on John Deere Credit Installment Plan. 0%APR for 24 months only. Some restrictions apply, so see your dealer for complete details and other financing options.



JOHN DEERE

www.JohnDeere.com/MowPro



Victims of our own promises?

It's mid-spring, and many of us are putting in 50 or more hours a week to meet property owners' expectations.

What level of expectations are we establishing with customers, especially in regard to landscape services? Are we promising perfection or near perfection? It seems many of us are, and, thanks to the knowledge we've gained about landscape care and to modern chemistry, we can almost make it happen. This in spite of unpredictable weather, techs who call in sick or mowers that go on the fritz midweek.

The bar is set high

There's a term for what some of us are promising. Let's call it the Augusta National Syndrome, after the private golf club in Georgia that each April hosts The Masters Tournament where an audience of millions is treated to days of televised coverage of images of perfectly manicured, weed-free, deep-green turfgrass in a landscape of spring-blossoming ornamentals in all of their pink, purple and milky white glory. I've often wondered if this spring spectacle — grass, flowers bluebirds and all — hasn't contributed to an unrealistic vision of what our own landscapes should look like.

I often wonder if we're **promising too much** and **doing too little** to provide customers a more sustainable understanding of their landscape care.

That kind of unnatural beauty comes at a steep price in terms of labor, equipment, chemicals and water. The golf club can afford it, of course, but can the rest of us. Or our environment, for that matter?

Yes, we in the landscape service industry have gotten expert in promising manicured, uniformly green and essentially weed-free turfsapes, not that the mowing, fertilization and pest control practices we've developed over the past half century haven't, served our clients and ourselves extremely well.

Even so, I'm beginning to wonder if we're promising too much and doing too little to educate ourselves, our teams and our customers to a more sustainable approach to landscape care.

I'm wondering if we're relying too much on many of the same practices that have gotten us to this point (for better or worse), and we're paying too little attention to the concerns of a growing segment of the public, lawmakers and regulatory authorities over issues such as emissions, noise, water waste, inappropriate chemical use and non-point-source pollution.

Yes, we know that by mowing turfgrass properly — no more than 1/3rd of the leaf blade and at a higher height — we can dramatically reduce weed populations using far less herbicides.

Yes, we know that once we improve clients' properties, following best management fertilization and pest control guidelines, we can maintain attractive lawns using far less pesticides. That's assuming we've established the proper level of expectations with our clients.

Yes, we know that bagging grass clippings is wasteful with little upside other than it allows us to meet the expectations we've set with certain of our clients — clients that don't understand the costs of bagging clippings, both financially and in terms of the environment.

Yes, there's a price to be paid for everything, and I'm convinced the closer we attempt to approach what I call The Augusta National Syndrome, the higher the price we pay.

THE ARMY KNIFE OF TURF HERBICIDES



NEW Q4® PLUS CONTAINS 0.75 LBS/ACRE OF QUINCLORAC FOR EXTRA KNOCKOUT POWER ON GRASSY WEEDS

CRABGRASS • YELLOW NUTSEdge • BROADLEAF WEEDS • TURF TOLERANCE • SPEED



G pbi / GORDON corporation
An Employee-Owned Company

800-821-7925 • pbigordon.com/q4plus

NOTE: Includes bermudagrass labeling

Q4®, ProForm® & Checkered Flag/Label Design are registered trademarks of PBI/Gordon Corporation. ALWAYS READ AND FOLLOW LABEL DIRECTIONS 01009

THE BIG GIVE

Landscapers across the country lend communities their time and talents.

BY **NICOLE WISNIEWSKI** EDITOR-IN-CHIEF

SURE, DISCOUNTS and add-ons can get customers in the door. But a growing number of clients aren't basing their purchasing decisions solely on service and price anymore. A business' social consciousness and community involvement also can turn customer heads.

Every day, more companies are watching their employees sign up early when the list goes up for blood donors, join teams to build Habitat homes, donate food and money to Harvest for Hunger or spend time as a Big Brother or Big Sister.

According to the Corporation for National and Community Service, 61 million Americans — 26% of the adult population — give approximately 8.1 billion hours and \$158 billion worth of volunteer service annually.

In terms of employer-sponsored volunteer programs, 81% of companies use them to support core business functions, and nearly 50% incorporate volunteer programs into overall business plans.

Green Industry businesses also are contributing to this growth. Compared to last year, 1,000 more landscape and lawn care professionals donated time and service to the Professional Landcare Network's second annual Day of Service on April 22 — the 40th annual Earth Day. This amounted to more than 3,000 people in 38 states and Canada.

Webster's defines community as a group of people with a common background or shared interests within a society, and ser-

continued on page 10



CALCP President
Andy Ferguson
helps rehabilitate
Riverside Cemetery.



MirrorScapes' employees helped revive Cross Mound Park while a pair of YardApes workers (inset) spread mulch at a newly installed playground.

DAY of SERVICE

FIELD REPORT #1:

Cross Mound Park
Tarlton, OH

13

FIELD REPORT #2:

Riverside Cemetary
Denver, CO

16

FIELD REPORT #3:

Children's Playground
New Milford, CT

24

continued from page 8
 vice as providing that community with something it needs. As a gathering place for family and friends, industry experts agree landscapes are at the hearts of these communities.

So as an item in a landscaper's marketing agenda, professionals recommend properly planned community service as a low-cost way to improve employee attitude and retention, enhance goodwill, drive revenue and soothe the soul.

Beefing up the bottom line

Research shows there is a direct correlation between active community outreach programs and increased revenue and customer loyalty for businesses that engage in helping their communities.

To measure return-on-investment from community service events, start by maximizing priceless advertising opportunities. Sending press releases before the event and choosing a highly visible or important town project can draw press. A front-page story in the daily local paper is invaluable ... and possible. It's happened to Shayne Newman, president of New Milford, CT-based YardApes two years in a row after his company's Day of Service projects (and as a result of other volunteer

Framed through a climbing wall, YardApes' crew install pavers.

efforts his company supports).

And what visibility like that brings is clear: Clients.

Last year, Greener By Design chose a Day of Service project located in a market CEO Richard Heller wanted to expand into. He picked up 22 clients in that new market, and 11 of them mentioned hearing about the company from his Day of Service project.

Adequate promotion of the work before and after the event helped boost these numbers. Heller videotaped his project last year, edited it down and put it up on YouTube and the company's Facebook fan page. Greener By Design typically picks up two to three new fans a week with fresh content, such as videos of employees at work to tips on growing herbs or trends in eco-art to updates on local speaking engagements or gardening classes.

In addition to proper promotion and planning, volunteering can directly influence sales through improved employee attitudes.



According to the study "Good Companies, Better Employees," some of the outcomes of effective employee volunteer programs include:

- Increased job satisfaction levels.
- Increased positive word of mouth among employees about their employer and an improved rating among employees for their employer as a place to work.
- Higher employee retention rates.
- Employees who participated in volunteer programs appeared to be more prone to pursue promotion and development activities in the months following the participation in the

continued on page 12

PHOTO BY: NICOLE MISNEWSKI

Helping Landscapers save money, no matter what they drive.

No matter what kind of vehicle you use for your business, you could save with Progressive Insurance. To learn more about Progressive, and see why we are the #1 Truck Insurer in America, please visit ProgressiveCommercial.com.



Call for a Free Quote | Find an Agent
 1-888-375-7908 | ProgressiveCommercial.com



United Financial Casualty Company and its affiliates, Mayfield Village, Ohio. Available in most states. No. 1 truck from Highline Data's 2007 written premium data. 09P00560.BA (12/09)





Onetime[®] HERBICIDE

You have enough things to worry about. But with **Onetime[®] herbicide**, wasting time tank-mixing isn't one of them. **Onetime** combines our new patented formulation of quinclorac, MCPP-P and dicamba, enabling you to control more than 70 weeds, including crabgrass, clover and dandelion *without* tank-mixing. Plus, its liquid formulation, which includes the same active ingredient as in **Drive[®] XLR8 herbicide**, provides more rapid absorption into the plant in both warm- and cool-season turf. If you've got weeds, it's time for **Onetime**.

betterturf.basf.us | 800-545-9525

 **BASF**
The Chemical Company

continued from page 10
volunteer programs.

The *Harvard Business Review* did a study of the linkage between employee attitude, customer relations and sales at Sears and found improving employee attitude by five points resulted in a 1.3-point improvement in customer satisfaction, which produced a 0.5% revenue hike. For a company like Sears, this amounts to \$65 million annually.

Do unto others ...

Heller admits he was a pretty shy kid growing up.

“I was a social moron,” says the outgoing president of PLANET’s Day of Service Committee. “It has taken years of my wife telling me to go and network for me to be comfortable speaking in public. She encouraged me not to talk about my business too much, but rather to take baby steps and be comfortable with each one. You can’t



The world on their shoulders: Mirrorscapes’ crew removes debris.

go straight from being shy to being a motor mouth.”

What helped Heller get over the rough spots was having a passion for what he was doing, including the various customer service projects his company supports. “It’s easier to talk about something if you really care about what you’re doing and whom you’re doing it for,” he explains.

When choosing a volunteer effort, passion is the most important criteria.

“You have to be excited about what you’re doing and feel good about helping someone who has a need,” explains Newman, the incoming president of the PLANET Day of Service Committee. “If you are excited and have passion, everyone you interact with — whether it’s your employees or vendors or the media — will feed off of your excitement.”

And that’s where one community service effort sets itself apart from another. Making a positive impact and growing employee and customer loyalty are all key drivers of volunteer efforts. But many Green Industry professionals who have had success here say none of this is possible by faking it. The primary rule of thumb: Believe in your project. “It’s more than just trying to make a good impression for the sake of making a good impression,” Newman says. “It’s about simply doing good because it’s the right thing to do.” **LMI**

PHOTOS BY: RON HALL



Quincept®

Stops esQapes dead.

X MARKS THE SPOT

Mirrorscapes refreshes the surroundings of mysterious — and beautiful — Cross Mound Park.

BY **RON HALL** EDITOR-AT-LARGE

NOBODY KNOWS the exact age of an ancient and mysterious Native American mound located at the summit of a wooded ridgeline in central Ohio. Most experts believe it was constructed about the time of the birth of Jesus. The X-shaped mound, whose circumference approximates the size of a Little League

infield, is the attraction at Cross Mound Park on the outskirts of the village of Tarlton (about 300 people), which is a 35-minute drive south of Columbus.

Chuck Miller selected Cross Mound Park as his company's PLANET Day of Service project. His company,

continued on page 14

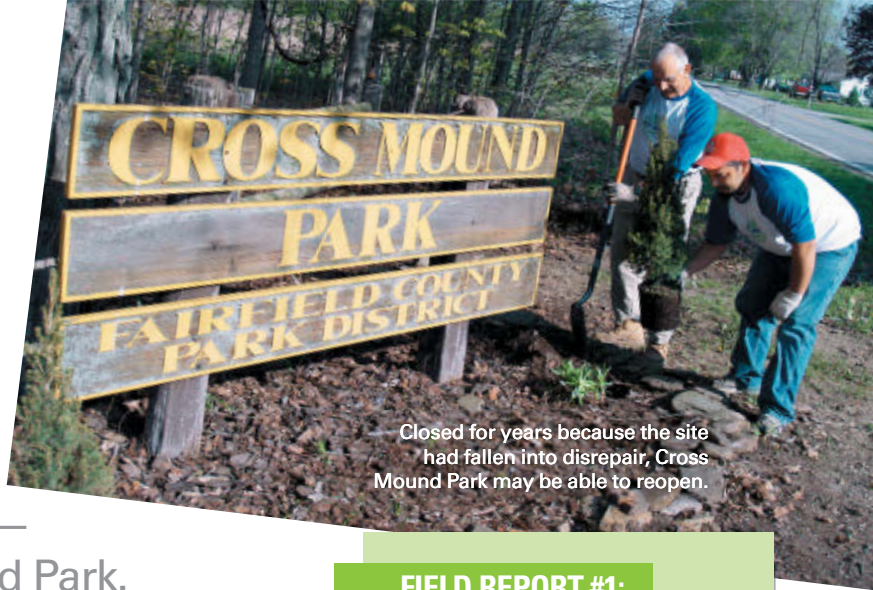

Closed for years because the site had fallen into disrepair, Cross Mound Park may be able to reopen.

FIELD REPORT #1:

Cross Mound Park
Tarlton, OH

Day of Service Mission:

Mirrorscapes team members repaired a split rail fence and cleaned debris from the Cross Mound Park.

EsQape-proof your weed control.

Even hard case weeds like crabgrass can't get away from Quincept® herbicide. With three active ingredients in rates that optimize performance, Quincept nails grass and broadleaf weeds that have escaped pre-emerge applications. See your distributor or www.nufarm.com/turf for more on how to put a stop to escapes.

Better Choices. Better Business.

© 2010 Nufarm. Important: Always read and follow label instructions. Quincept® is a registered trademark of Nufarm.



www.nufarm.com/us

continued from page 13

MirrorScapes LLC, proves you don't have to be a big landscape company or one that's been around a long time to do something nice for your region. Miller, 52, founded MirrorScapes in nearby Lancaster, OH, three years ago as he was winding down a 30-year-career as a high school educator — much of it spent teaching agriculture.

His company has four trucks and employs “seven or eight” employees, adding part-time help as needed for bigger projects. Miller's top challenge this spring has been reining in his firm's rapid growth, thanks to its “follow-up and customer service” and, more recently, to winning a prestigious award for its display landscape at the Tri-County Home Builders Home and Garden Show in March.

“We've been going like crazy. The phone's been ringing off the hook,” says



On the bridge to recovery: MirrorScapes' crew brings new life to Cross Mound Park.

Miller, obviously pleased as he and his six-man crew load two work trucks for the morning's work at the park. “We needed a break. The guys needed something different to do. They've been putting in a lot of hours.”

His young crew (including “plant man” Lennie Conrad, a retired high school guidance counselor/coach and

several years Miller's senior) approaches the Earth Day project with unfeigned enthusiasm, fueled probably as much by the prospect of a working picnic in the park — as evidenced by the boxes of goodies being loaded into the trucks — as by the cloudless, bracing April morning.

Driving three trucks to Cross Mound Park, and after digging into pastries and

PHOTO BY: RON HALL



SPRINTER

orange juice, the workers scatter about the 29-acre site. Several employees hike across the bridge spanning Salt Creek, built in 1936 as part of the Work Projects Administration (WPA) program, and up a woodland path to the ancient Cross Mound. There, they replace a section of broken split rail fence and clear it of seasons of broken tree limbs, rotting logs and an ankle-deep layer of brittle, dry oak leaves.

The freshly uncovered earthen mound clearly reveals its perfect X shape that, in spite of being surrounded by mature eastern woodlands, has — through some treatment or process known only to its builders — remained, to the bewilderment of many experts, vegetation-free for two millennia or more.

Elsewhere in the park, other employees focus on the park's entrance, where they weed, trim, plant ornaments and put down dark, fragrant mulch.

Amid the roaring and whirring of blowers, mowers and trimmers, David J. Fey, director/secretary of Fairfield County Parks, stops by mid-morning to thank Miller and his team. Fey is the sole employee of the park system. Age 65 and a retired teacher himself (biology), Fey is tasked with maintaining five covered bridges, several historical buildings, nature preserves and a sculpture garden as well as Cross Mound. Even after 11 years on the job, he approaches his duties with an unabashed interest and love for the county's rich cultural history. He also welcomes any help he can get for the cash-strapped park system.

Unfortunately, because of a lack of funds and ongoing vandalism at Cross Mound, Fey has had to keep the park entrance gate closed. (You can still hike to the mound if you park just outside the gate. There's room for one vehicle.)

Miller, whose Day of Service project

in 2009 was at the county's Lockville Park, is pleased to be of help and obviously enjoying his half-hour chat with Fey. Then, it's back to work for the both of them.

"I'm really enjoying this 'retirement,'" says Miller, taking a short break as noon approaches. "Every once in a while, an acquaintance from the school will call and ask what I'm doing and I'll say, 'I'm outside and enjoying it.' And, yes, I work with the crews and then I come home and do the paperwork."

Miller says he has no plans for a second retirement, and he wants to continue to grow his landscape company as circumstances allow.

But we had to know: What exactly was the inspiration behind the company name, Mirrorscapes?

"It's our tag line. Your lawn is a reflection of you," says Miller with a broad smile. **LM**



HEAVY ON THE LIFTING. LIGHT ON ITS FRAME.

The 2010 Freightliner Sprinter Cab Chassis proves that it doesn't take a heavyweight to carry heavy loads. Its lightweight, all-steel, unibody frame handles a Best-In-Class* payload up to 6,269 lbs. And with numerous upfit options and body packages available, the Sprinter Cab Chassis has the versatility to carry any business. Visit FreightlinerSprinterUSA.com or your local dealer to discover your Sprinter today.

*Based on a comparison of the Automotive News classification of full-size commercial vans.



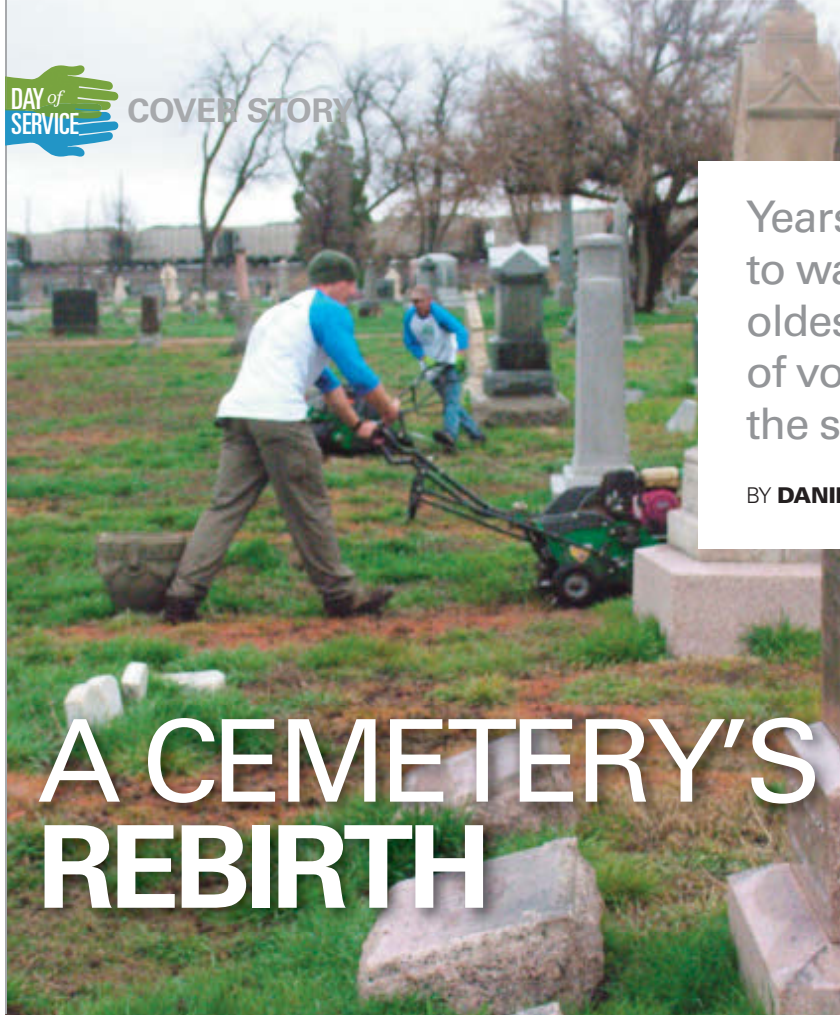

A CEMETERY'S REBIRTH

Years after losing the ability to water one of Denver's oldest cemeteries, a group of volunteers works to revive the site with native species.

BY **DANIEL G. JACOBS** MANAGING EDITOR

PATRICIA CARMODY steers her white Subaru Outback wagon along the bumpy dirt and gravel road that winds its way through the 77-acre Riverside Cemetery, Denver's oldest operating cemetery. She muses about her desire to find a scout troop in search of a community service project, and a benefactor willing to donate some gravel to repair the many potholes dotting the road, now oozing with mud following the morning's cold shower. But the sun has

continued on page 18

PHOTO BY: DANIEL G. JACOBS

We are actively seeking Landscaping Professionals to sell, install and service our innovative outdoor misting systems that effectively control mosquitoes and other annoying insects.

Great margins and recurring revenues!

1-866-485-7255
WWW.MISTAWAY.COM

Is this how your clients are enjoying their new landscaping?

BECOME A MISTAWAY DEALER TODAY!



Knock out multiple weeds in a single round.

Only Solitare® takes on crabgrass, sedges and broadleaf weeds with no tank mixing required.

Fighting more than one weed problem used to require more than one product. Now there's new Solitare® herbicide from FMC Professional Solutions, the only all-in-one postemergence solution designed to help you control multiple weeds in a single, fast-acting application.

Wherever several weeds like crabgrass, sedges and broadleaf weeds come together, you'll experience the Solitare "sweet spot." That's because Solitare controls or suppresses over 60 weeds without the hassle and cost of tank mixing. Dual-action Solitare herbicide features a patent-pending combination of active ingredients that combats weeds from the foliage down and the root up. Solitare also impacts viability of seeds and tubers within the soil, helping to decrease weed populations this season and next. When multiple weeds gang up on you, there's only one solution you want in your corner: Solitare herbicide.

For more information on Solitare and other solutions from FMC, visit www.fmcprosolutions.com or contact your FMC Sales Representative or local FMC Distributor.

FMC

FMC Professional Solutions

1-800-321-1FMC • fmcprosolutions.com

Solitare®
HERBICIDE

continued from page 16
since come out, and wispy clouds waft through a blue sky over the cemetery — through which volunteers scurry about, working on a number of projects as part of PLANET's second annual Day of Service.

Carmody passes a small raised

planter and stops both the car and her conversation. She catches her breath slightly as she sees the work some of the volunteers completed earlier. Within a few hours, the planter went from weed-filled to tilled bed to beautiful display of native and specially selected flowers, all to please visitors coming to honor the

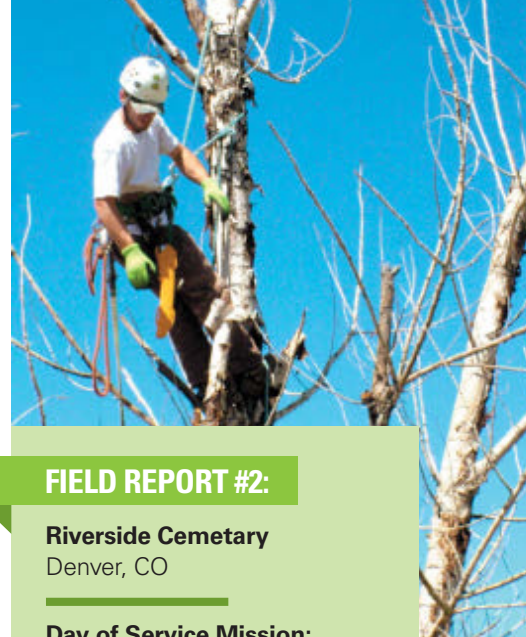

FIELD REPORT #2:

Riverside Cemetery
Denver, CO

Day of Service Mission:

The Riverside Cemetery lost watering rights which left a number of plants and trees dead.

67,000 friends and loved ones buried in the 134-year-old cemetery.

“Look at that,” says Carmody, executive director of the Fairmount Heritage Foundation, which oversees the cemetery. Still wearing the plastic-garbage-bag-turned-rain-poncho, Carmody stares in awe at the transformed planter. “I am so grateful. It’s the revival of Riverside.”

Dozens of volunteers come courtesy of the Colorado Association of Lawn Care Professionals (CALCP) to prep and plant 2 acres of groundcover; install a variety of native trees, plants, and shrubs; plant a heritage iris garden; and remove a number of dead heritage trees — including an approximately 80-year-old American elm.

Though it will take years to complete, the goal is to make the cemetery sustainable. The only watering done will be until the plants are established.

CALCP committed to reviving the cemetery, which fell into disrepair after the organization overseeing the site lost a long court battle that went to the Supreme Court over water rights.

“This is one of my favorite days of the year,” says Andy Ferguson, president of CALCP and the district manager of the West Denver office of The Davey Tree Expert Co. “Our members show up in force.”

continued on page 20

PHOTO BY: DANIEL G. JACOBS

Sprinkler Adjuster,

Wire Cutter,

Time Saver.

With a built-in sprinkler adjuster and wire cutter, you can now do more in less time. Razor-sharp, ultra-tough and all-day comfortable, the new BP 3670 cuts up to 1" — and it'll turn heads for years to come.

CORONA

coronaclipper.com 800-847-7863



IT'S BIGGER THAN IT USED TO BE.

KIND OF LIKE YOU.



ARE YOU M-POWERED?

Sometimes bigger is better. Like the new cab on the Bobcat® M-Series loaders. Bobcat lowered the door threshold and increased the size of the front access to give you an easier entry and exit – also making it easier to see and do your work. Bobcat increased the cab space by 10%, giving you more room where it matters at your arms, legs, shoulders, head and feet. You can grow comfortably with the new Bobcat M-Series loaders. Go to www.bobcat.com/bigger19 to learn more, or see your dealer to find out how these new loaders can M-Power you to do more.

THE NEW S650 SKID-STEER LOADER

www.bobcat.com/bigger19

Bobcat® and the Bobcat logo are registered trademarks of Bobcat Company in the United States and various other countries ©2010 Bobcat Company. All Rights Reserved.



Bobcat®

One Tough Animal™

continued from page 18

Providing labor and equipment for half a day means those workers, machines and vehicles aren't doing work the company can bill for. But that's not really the point.

"It's a great way for us to make a big impact without impacting our ability to make some money," Ferguson says.

Companies from across the state and across the country participated in a variety of projects.

"We found out about Day of Service two years ago," says Bryan Gooch, marketing manager for Agrium Advanced Technology. "We jumped on the opportunity to be a lead sponsor. It is perfectly aligned with what we believe in. We saw Day of Service as not only a chance to give back to the communities that we live in, but also to donate products to people who can help extend the message, and let them use products



Workers install native plants at Riverside Cemetery. Lifescape Associates Troy Shimp and Michael Hupf (inset) create a healing garden at the Denver Children's Advocacy Center.

that are good for the environment."

Loveland, CO-based Agrium volunteers worked on their own project near the company's new headquarters (transplanting native plant seedlings to help restore wetlands and natural areas) and donated fertilizer to several more.

Planting the seeds for healing

While CALCP members toiled away at the Riverside Cemetery, about 20 min-

utes away Troy Shimp, senior designer for Denver-based Lifescape Associates, and his team started working on a healing garden between two buildings that house the Denver Children's Advocacy Center (DCAC). Though the rain only slowed the crew at Riverside Cemetery, it put a halt to the day's work at the DCAC. But that only meant the crew would be back at the next opportunity.

"We see giving back to the commu-

PHOTOS BY: DANIEL G. JACOBS

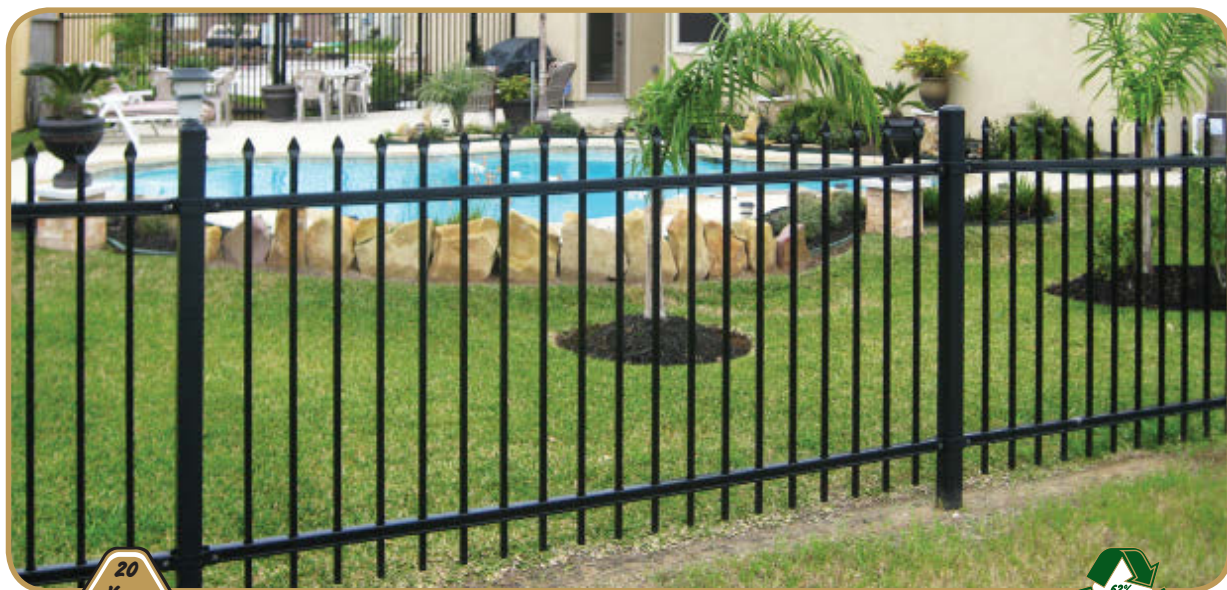

Fusion-welded for durability • E-coated maintenance free finish



1555 N. Mingo Road Tulsa, OK 74116

AMERISTAR FENCE.COM

Phone 1-888-333-3422 Fax 1-877-926-3747

Email: mktg@ameristarfence.com

Cut Costs!

nity as very important,” says Michael Hupf, CEO of Lifescape Associates. “For us, it creates a huge sense of teamwork.”

In all, about 15 workers will install scores of plants, trees and shrubs — along with a flagstone patio to create a seating area.

“The addition of the Children’s Healing Garden ... will make our facilities more beautiful and provide a better experience for the children and families we serve,” says Dr. Gizane Indart, executive director of the DCAC. **LM**

RIVERSIDE CEMETERY PROJECT PARTICIPANTS

A number of organizations from CALCP and a few other organizations volunteered their time and effort to the Riverside Cemetery Revival project as part of PLANET’s Day of Service on Earth Day 2010:

Agrium Advanced Technologies
Alpha One Inc.
Arkansas Valley Seed
Barr Lake Nature Center
Colorado Forest Service
Colorado State University
Colorado State University Master Gardeners
Colorado Tree Coalition
Davey Tree Expert Co.
Denver Botanic Gardens
Denver Rose Society
Fertek Co.
Front Range Community College
Green Mountain Lawn Service
Helena Chemical Co.
International Society of Arboriculture
Iris Colorado
John Deere Landscape
L.L. Johnson Distribution
Million Tree Project
Organix Supply
Pawnee Buttes Seed
Project Learning Tree
Scotts Lawn Service
Swingle Lawn, Tree & Landscape Management
Timberline Landscaping
Welby Gardens



Cut Operating Costs - And Increase Profits!

Looking for a place to cut operating costs? Atrimmec® can reduce labor and disposal costs by 50% or more. Use the on-line Atrimmec Trimming Cost Calculator at pbigordon.com/trimmingcalculator to input your current costs and compare. See for yourself how Atrimmec can enhance your profit potential.

Easy Spray Application • Irrigation Not Required • No Affect On Turf

800-821-7925
pbigordon.com/atrimmec

G pbi / gordon
CORPORATION
An Employee-Owned Company

Atrimmec® is a registered trademark of PBI/Gordon Corporation. Always Read and Follow Label Directions.

00804

WHAT GOES AROUND, COMES AROUND



YardApes' Owner Shayne Newman chats with Parks & Rec committee members and the New Milford mayor.

YardApes' Shayne Newman is a big believer in good karma, and that's why his investment in community service marketing has yielded great return — in more ways than one.

BY **NICOLE WISNIEWSKI** EDITOR-IN-CHIEF

SOME PEOPLE think Shayne Newman is a mastermind when planning community service and gaining recognition for his New Milford, CT-based company, YardApes.

"They think I know it all when it comes to these events," says the incoming president of the Professional Landcare Network Day of Service Committee. On a recent PLANET Webinar on the topic, moderator and industry consultant Jeffrey Scott even called Newman a

continued on page 24

PHOTO BY: NICOLE WISNIEWSKI

You need eight rotors, two shovels and one piece of good advice.
You only have time for one stop.

YOU NEED

Horizon Distributors.

Horizon gives you the edge you need by providing professional landscaping products, all backed by personalized service.



Cap off your next visit to Horizon with a **FREE HAT** just for mentioning this ad.

Irrigation ♦ Specialty ♦ Landscape ♦ Equipment ♦ HorizonOnline.com

© 2010 Horizon Distributors, Inc. All Rights Reserved.

Horizon
The Edge You Need



Fungicides. Because you're not the type to leave a job undone.

Unfortunately, skipping a fungicide application is not nearly this noticeable—at first. But it will be. And you are not the type to leave a lawn *unfinished* and *unprotected* all season long. Encouraging homeowners to let you finish the job is an upsell opportunity for your business.

To help explain disease control to your homeowners, we are offering a free Lawn Disease ID Guide, one per route truck. Call 1-800-395-8873 to receive this helpful Syngenta sales tool.

©2010 Syngenta Crop Protection, Inc., P.O. Box 18300, Greensboro, NC 27419. **Important: Always read and follow label instructions before buying or using Syngenta products. The instructions contain important conditions of sale, including limitations of remedy and warranty.** The Syngenta logo is a registered trademark of a Syngenta Group Company.

syngenta

continued from page 22
community service “rock star.”

What’s his *real* trick? “I just get lucky,” says Newman, crossing his arms over his chest and shrugging his shoulders. He squints in the sun at his team of 12 working in khakis and blue, white and green PLANET Day of Service shirts at a town playground on April 22. It’s a cloudless,



Spread the love: YardApes’ crewmembers shovel topsoil and plant turf seed.

FIELD REPORT #3:

Children’s Playground
New Milford, CT

Day of Service Mission:

YardApes donated their time and energy to move 60 yards of topsoil, plant turf and install a paver patio at a children’s park in Connecticut.

70-degree day. One couldn’t ask for a better morning to move mulch and 60 yards of topsoil, plant turf seed and install a paver patio walkway in a children’s park that needs some attention.

On this Earth Day, Newman donates services worth \$7,000 to the community park. And where this “luck” is concerned, Newman is on a winning streak.

Instant karma

Five years ago, when he held his first community golf fundraiser, Newman raised \$10,000 for his charity and maxed out at 120 golfers. Last year, on his first PLANET Day of Service, Newman’s event was featured on the front page of the local garden club’s newsletter — as well as the local daily newspaper. This year, because the playground is a hot-button issue in the town, reporters showed up again.

Also in attendance is New Milford Mayor Patricia Murphy, as well as Dan Calhoun and Eleanor Covelli — the director and assistant director of the Parks & Recreation Department, respectively. As this trio and several members of the media survey the project while the crew works, Newman talks to them with ease about the park

continued on page 27

PHOTO BY: NICOLE WISNIEWSKI

There’s business out there. Get more of it. Guaranteed!

Maximize your chances to win that new landscape or renovation project using the most complete landscape design software available. PRO Landscape will help you communicate your designs with stunning photorealistic 3D images, easily create accurate 2D and 3D CAD drawings and automatically generate professional proposals. We guarantee you’ll sell, plan and bid better than ever before, or we’ll give you your money back.



“I’ve won every bid when I’ve used PRO Landscape.”
Aron Hoffman, Groundskeepers Landscaping, Inc.



VISUAL DESIGNS THAT SELL

Excite customers with photos of their home with recommended landscaping in place.



PROFESSIONAL PROPOSALS

Show your professionalism with complete, polished proposals prepared in seconds.

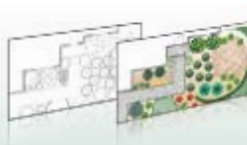

ACCURATE SITE PLANS

Easy-to-use CAD lets you quickly develop detailed, accurate site plans.

drafix software, inc.

PRO Landscape™

The Standard in Design Software for Landscape Professionals!

prolandscape.com

800-231-8574 or
prolandscape@drafix.com

SELL BETTER • PLAN BETTER • BID BETTER

Does your insurance company think a “grub problem” means mystery meat monday?



In a competitive business environment, you can't afford an insurance company that doesn't understand your business. Hortica has over 120 years experience in the horticultural industry. We provide specialized insurance solutions and loss control strategies that other companies don't deliver.

To learn how Hortica can help protect your business visit www.hortica-insurance.com or call 800-851-7740.

hortica
INSURANCE & EMPLOYEE BENEFITS
To guide and provide

“In **this** neighborhood,
PERFECTION
is the only acceptable
RESULT.

That's why I use
4-Speed™ XT.”

Eric Larson, Green Systems Turf Management
Site: Astor's Mansion
Newport, Rhode Island

With contracts for many of the world's most famous mansions, Eric Larson faces customer expectations that are as high as the real estate prices. So when ground ivy, clover and other tough weeds started showing up, he turned to 4-Speed XT. Its combination of four active ingredients makes weeds 'Deader. Faster.' For more on 4-Speed herbicide brands, and more of Eric Larson's story, go to www.nufarm.com/us.

Better Choices. Better Business.

© 2010 Nufarm. Important: Always read and follow label instructions. 4-Speed™ is a trademark of Nufarm.



www.nufarm.com/us

COVER STORY



Laying the groundwork: Workers meticulously lay the paver pattern, above, and a crewmember's son, right, enjoys the playground after the hard work is done.

continued from page 24

maintenance, as well as other projects that need assistance. It's certainly not bad company to keep when you're a landscape contractor.

"Yeah, that was pretty cool that the mayor showed up," Newman says, nonchalantly.

There's one theory Newman uses to explain this good fortune. Deep pockets? No. Political agenda? No. Ingenious planning? A little. Right place, right time? Maybe. However, Newman says he can sum it up with just one word: Karma.

"I believe that if I do good things then good things will come back to me," he says. "It might not be today or tomorrow, but somewhere down the line it will pay off."

That's when you see it. The immense pride. Newman swells with it as he watches his crew in action while juggling reporters' questions and mingling with the mayor.

"We are working on two projects today, and 15 of my 17 guys volunteered to help — unpaid," he says, beaming.

This fact you wouldn't know off-hand. The crew is as focused as usual. Crewmembers Ramiro Parra and Franklin Guaman, who were installing the paver patio walkway, are meticulous in their laying of the pattern — a design that duly impressed the mayor. Just a normal day's work? Hardly.

"My wife and kids come here all the time, and people in town will know we did this. It has to be perfect," Parra



says to Newman.

And it is — down to the last brick engraved with a special message: "Walkway Donated by YardApes Landscaping."

Though Newman hasn't crunched the numbers on exactly the type of return-on-investment this community service event will provide, he knows there is value he can't compute. After all, how much could you pay for the front page of the local daily paper? What price can you put on more than an hour of undivided attention from the city mayor? What about employee excitement and pride? Or the number of current and potential clients who say they saw what YardApes did for the community?

"I'm a numbers person, and I can get really into the processes," Newman admits, taking a bite of the pizza he provided his crew for lunch. "But I try not to get too wrapped up in numbers during Day of Service.

"It would take away from the good feeling I get just by giving back," Newman says, "and that is bigger for me than anything I could get back monetarily." **LM**

BETTER RESULTS



4-Speed™ XT Saves Contracts

APPLICATION RATE:

1.3 oz/1,000 sf of 4-Speed XT plus spreader-sticker (1 oz/gallon finished spray)

APPLICATION EQUIPMENT:

LT Rich Z-Sprayer, 1/3 gal spray tips

TIMING:

July 13, 2009

SUMMARY:

"This was not ideal herbicide application timing for ground ivy control, but we still had great results on it and all the other weeds on the 4-Speed XT label. As a result, we saved several contracts. We'll be using a lot more 4-Speed XT and other Nufarm products in the future."

4-SPEED™ XT

**Better Choices.
Better Business.**



www.nufarm.com/us

Nufarm Turf & Ornamentals: 800-345-3330
© 2009 Nufarm. Important: Always read and follow label instructions. 4-Speed™ is a trademark of Nufarm.



THE BENCHMARK

KEVIN KEHOE

The author is the owner-manager of 3PG Consulting. Contact him at kkehoe@earthlink.net.

Keys to managing a sales machine

Developing a sales machine is the most important investment a landscape contractor can make. Given pricing conditions and the negative impact this is exacting on gross profit margins, generating increased revenue volume is necessary to achieve net profit dollar goals.

Key to this revenue generation effort is the sales team. The team has never been more important, and its management has never been more critical.

The sales game is a tough one, and lack of success can cause even the best to go into a slump. Keeping your sales staff motivated is essential. The primary motivators include:

- › the need for achievement,
- › the desire to get better, and
- › the opportunity to make money.

To produce these motivators, try using the classic carrot-and-stick approach.

Carrot

Goals and commission programs provide the carrot. Goals should be set weekly for number of sales calls, monthly for the dollar value of bids required, and quarterly for every quarter for closed revenue volume.

In my experience, most managers set goals too low. Low goals provide little pressure, and most salespeople are motivated by pressure.

Commission plans are essential. A successful salesperson should be the second- or third-highest paid employee in the company. I prefer a first year 60/40 base/commission structure, graduating it by the third year to a 40/60 with unlimited upside for the sales rep.

Salespeople are motivated when there is something at risk. When pay is guaranteed, they don't run as hard.

Stick

Dashboards and coaching provide the stick. Most contractors do a good job managing production.

Yet they don't apply this same principle to the sales. Salespeople perform better when they are focused on high-return activities. The dashboard is the pipeline report. It is a necessary "stick" because too many salespeople spend too much time:

- › selling to people they know and too little to those they don't, and
- › working on prospects that ultimately have little chance of closing.

Salespeople need feedback. All good salespeople have had the experience of wishing they had been quicker or smarter at some point during a call. Making joint calls and engaging in post-call "curbside chats" applies the stick gently and motivates them to become better.

In working with salespeople, I have discovered some typical bad habits that can be easily addressed by this method. These include:

- › talking too much,
- › not asking the right questions,
- › arguing with the customer, and
- › failing to ask for the business and get a signature.

No salesperson is immune to these behaviors. Some years ago, in an important sales presentation, a customer actually said to me more than once, "Kevin, ask me if I want to sign this contract."

Apparently, I did not hear this. Instead, I proceeded to provide him with proof and testimonial to my wonderfulness until he finally became adamant. "Ask me!" he said.

At this point, I said, "Would you want to sign this contract?"

He said, "Yes. Now let's talk schedule. When can you start?"

I was so busy talking and avoiding the potential rejection that comes with "NO" that I never asked the closing question. It is a lesson I have never forgotten: Salespeople require the coaching stick.

The best salespeople are hard-wired for the job. At their best, salespeople are capitalist athletes. They like to win. And when they are not winning they are high-maintenance time wasters.



THE WINNING FORMULA FOR RESISTANT CHINCH BUG.

Southern chinch bug resistance has become a big problem in St. Augustine grass. So if you're trying to save a few bucks by using older products, you're risking more than costly callbacks—you're risking business. Get the best solution for chinch bug control with Arena[®] Insecticide. Arena controls pyrethroid-resistant chinch bug and has the longest-lasting residual on the market. One application can bring up to eight weeks of consistent Southern chinch bug control. It's also effective on a broad spectrum of other pests including white grubs. And Arena has lower water solubility than other neonicotinoids, so you're less likely to have to reapply after rain. Which all adds up to happier customers and a successful business.



A BETTER VALUE THAT LASTS.
AND LASTS. AND LASTS.™



Products That Work, From People Who Care[®] | www.valentpro.com | 800-89-VALENT (898-2536)

Read and follow the label instructions before using.

A better value that lasts. And lasts. And lasts. is a trademark and Products That Work, From People Who Care is a registered trademark of Valent U.S.A. Corporation. Arena is a registered trademark of Sumitomo Chemical Company, Limited.
©2010 Valent U.S.A. Corporation. All rights reserved. AM22453.7

chinch bug (including pyrethroid-resistant)
billbugs | white grubs | ants | more

LM REPORTS

YOUR GUIDE TO PRODUCT RESEARCH

LAWN CARE: INSECTICIDES

Bayer Environmental Science

TopChoice insecticide is based on the powerful active ingredient fipronil. Just one broadcast application of the ultra-low-dose granule provides 95% control of fire ants for up to one year. TopChoice also controls mole crickets, fleas, ticks, and nuisance ants when treating for fire ants. *BackedByBayer.com*



BASF Professional Turf & Ornamentals

Amdro Pro Fire Ant Bait insecticide delivers cost-effective control of imported and native fire ants and offers flexible dose and application options for single mounds or large areas. When used as directed, Amdro Pro eliminates the queen and her colony within seven days of a mound treatment, and rids an entire infested area of fire ants within two weeks of a broadcast application. *BetterTurf.BASF.us*



FMC Professional Solutions

New Talstar XTRA granular insecticide eliminates dangerous fire ant colonies in four hours or less — meaning you bring your customers peace-of-mind faster than ever. Its optimized combination of zeta-cypermethrin and bifenthrin provide fast-acting, long-lasting control of more than 75 pests. The product will be available by June 1. *FMCTProSolutions.com*

Syngenta

Meridian insecticide (thiamethoxam) offers both control and application flexibility in managing a broad spectrum of grubs and insects on turf, trees and shrubs. Meridian 0.33 G granular formulation contains .05 oz. of active ingredient per pound of formulated product, and is packaged in 40-lb. resealable bags. Water-dispersible Meridian 25WG contains 4 oz. of active ingredient per pound of formulated product, and is packaged in 4- and 17-oz. bottles. *GreencastOnline.com*

MAINTENANCE: ALTERNATIVE FUELS

Gravely

The Pro-Master 260H LP XDZ, a propane-powered zero-turn mower, is available with a 60-in. cutting width. The mower features a 28 hp/992 cc Generac Liquefied Petroleum (LP) engine with heavy duty air cleaner and uses twin 33-lb. LP tanks (not included). The aluminum 33.5-lb. fuel canister for the LP unit is common across many equipment platforms, reducing fuel logistics for a commercial user. *Ariens.com*



AgriFab

Ideal for spaces smaller than 1,000 sq. ft., the new electric dethatcher eliminates the mess and fuss of gas and oil: Connect an extension cord to the dethatcher and plug it in. No tools are needed to adjust dethatching height; just pull an easy-to-move handle. The 40 stainless-steel tines are designed to protect against rust and wear and tear, while quickly removing thatch buildup for a healthier lawn. For assembly, simply attach the pre-assembled handle to the pre-assembled base. *Agri-Fab.com*



Worx Yard Tools

The new lineup of 18-volt, lithium-ion battery powered-tools includes a two-in-one grass trimmer/edger (WG151), hedge trimmer (WG251) and sweeper/blower (WG540). The tools, which bear the Energy Star label, are as much as 35% lighter than competitive models. The emission-free products hold their charge for long periods, and have seasonal operating costs of less than a dollar. *WorxGT.com*

continued on page 32



DRIVE XLR8 HERBICIDE

You've got enough things to worry about. But with **Drive® XLR8 herbicide**, rain isn't one of them. Our new liquid formulation is rainfast in just 30 minutes. And a single application quickly controls a broad spectrum of broadleaf and grassy weeds — from crabgrass and foxtail to clover and dandelion — even at low use rates per 1,000 square feet. Let it rain. You've got **Drive XLR8**.



betterturf.basf.us | 800-545-9525

BASF
The Chemical Company

LMREPORTS

continued from page 30

IRRIGATION: DRIP UNITS

Hunter Industries

Hunter's Professional Landscape Dripline applies water slowly and evenly for consistent distribution. Water soaks in gradually, easily reaching its intended goal. It incorporates a pressure compensated and check valve emitter that prevents clogging and keeps water in the tubing between cycles. It's flexible- and kink-resistant, with industry-standard flows and spacing. HunterIndustries.com



Rain Bird

As the latest innovation in the Rain Bird Xerigation Family, the XF-SDI Series Sub-surface Dripline offers up to 90% watering efficiency for turf grass, shrubs and groundcover. Because the dripline is buried underground, it is unaffected by wind, evaporation or vandalism, effectively watering plants and turf while using 30% to 70% less water than overhead sprays. The patent-pending Copper Shield Technology protects dripline emitters from root intrusion without the use of chemical-treated filters. RainBird.com/drip/index.html

John Deere Water

Ro-Drip's patented design employs two independent anti-plugging systems: Vortex Flow Action, which resists clogs by keeping particulate in suspension; and the exclusive Expanding Flow Channel, which reacts to blockages by actually changing shape, often pushing even the toughest particulate build-up. JohnDeereWater.com



The Toro Co.

Pre-packaged and ready for installation, Toro Drip Zone Valve Kits provide everything you need for drip zone automation. Choose from Toro EZ-Flo Plus or TPV valves for residential and light commercial applications, or the 700 Series UltraFlow valve for commercial and institutional applications. Toro's Y-Filter features a 150-mesh stainless steel screen filter to assure clog-free operation. Kits also include a pressure regulator to prevent emitter blowouts, as well as needed fittings. Toro.com

How long does a Corona last?



We'll let you know when we find out.

You shouldn't have to buy a tool twice. Get it right the first time with a Corona, built tougher than any on the market.



CORONA

coronaclipper.com 800-847-7863

X-CEPTIONAL RESULTS that won't exceed your budget.

Your turf gets the nutrients you're paying for with XCU Slow-Release Fertilizer. Each XCU granule delivers the most bang for your buck of any Polymer-Coated, Sulfur-Coated Urea (PCSCU) thanks to its superior, more durable coating technology. When using XCU in your blends, you can be assured of a consistent, more predictable nutrient release for healthy, green turf.

Boost your bottom line.
Ask your distributor for XCU in your blend.



Slow-Release Fertilizer

Learn more at agriumat.com/XCU.

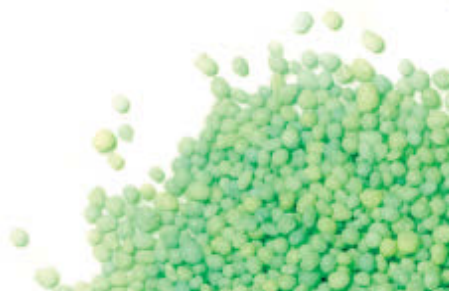



John Gibson was well on his way to an electrical engineering degree when a summer job cutting lawns for Tom Garber, a former president of the Associated Landscape Contractors of America (ALCA) changed his plans. Gibson joined Swingle in 1991, starting in ground maintenance. From there, he took over care/plant health care and eventually was named director of operations, overseeing acquisitions, geographic expansion and technology upgrades and implementation.

You became president of Swingle in the fall of 2008. What do you see as your chief responsibility within the company? My primary role is to lead and motivate our team to accomplish our goals in line with our overall strategic plan. This includes maintaining our strong culture, coordinating the activities of our executive team, overseeing our financial management and, of course, leading our team.

What changes have you seen in the Denver-area lawn care market since joining Swingle? The industry has matured dramatically, but there continues to be many new companies starting up in our market. Most of them are small, but the individuals running them are strong and some are entrepreneurial. Of course, there are more than a few not-so-professional operators, too. Swingle's focus remains — as it's always been — about keeping our promises. As our business

grows, we keep growing our highly trained, professional staff. We are capable of helping our customers with almost every service their landscapes require.

Describe the state of the economy in your market and its effect, if any, on professional lawn care services. The local economy started to slip in the fall of 2007, which continued throughout 2008 — and by the spring of 2009, it reached its lowest point. This spring, we're seeing modest recovery in our other services, especially tree work, but we think it will probably be the spring of 2011 before lawns start to pick up to the level we would like to see them.

Swingle's market, the Front Range of the Colorado Rockies, gets lots of sunshine and

mild temperatures, but is semi-arid with not-infrequent droughts. What does this mean for lawn care? Basically, it means we have to be aware of and educate our customers about any water restrictions we may currently have. It also means we have to focus on teaching our customers how to water for the best results over the long run, so restrictions don't dramatically change the look of their lawns.

You have served on many industry committees and taken leadership roles both in Colorado and nationally, as a past president of the Professional Landcare Network (PLANET). What have you learned from these experiences? I was encouraged by the example of the mentor I work for at Swingle, Tom Tolkaacz. Industry involvement

AT A GLANCE

COMPANY: Swingle Lawn, Tree & Landscape Care

FOUNDED: 1947

TITLE: President

NUMBER OF LOCATIONS: Two (Denver and Fort Collins, CO)

INDUSTRY INVOLVEMENT: Chair for the Irrigation Landscape Industry Certified Technician Test for the Associated Landscape Contractors of Colorado; director for the Green Industries of Colorado (GreenCo); past chairman of GreenCO's Water Efficient Leaders in Landscape Program; past president of the Colorado Association of Lawn Care Professionals; former VP of the Professional Lawn Care Association of America (now part of the Professional Landcare Network (PLANET)); past president, PLANET.

EDUCATION: B.S. business management from the University of Phoenix

WEBSITE: myswingle.com

has been one of the most rewarding experiences of my personal and professional development. It's allowed me to get to know and to learn from and share with the best people in our industry.

MY ROLE IS TO MOTIVATE OUR TEAM TO ACCOMPLISH OUR GOALS IN LINE WITH OUR STRATEGIC PLAN



If only everything worked as fast as Dismiss.[®]

Satisfy your need for speed with Dismiss herbicide, the fastest visible control of sedges available.

With all the things you have to do, you don't have time to wait around for your sedge control to start working. That's why FMC Professional Solutions formulated Dismiss for faster, visible control against yellow nutsedge, green kyllinga and purple nutsedge* than any other product.

Dismiss starts working immediately, producing noticeable signs of control in just 24 to 48 hours. University research trials have demonstrated greater than 90% control within a week, before other products begin to work. What's more, Dismiss also prevents sedge tubers from germinating, helping you avoid future outbreaks and reducing the need for re-treat applications. Once you've experienced the fast-acting, long-lasting control of Dismiss, you'll wish everything on the job kept you working at top speeds. For more information on Dismiss, visit www.fmcprosolutions.com or contact your local FMC Sales Representative or FMC Distributor.



FMC Professional Solutions

1-800-321-1FMC • fmcprosolutions.com



*For purple nutsedge, two applications of Dismiss turf herbicide are recommended for optimal control. Always read and follow label directions. FMC and Dismiss are trademarks of FMC Corporation. ©2010 FMC Corporation. All rights reserved.

WEEDWATCH

STANDING SENTINEL TO PROTECT PLANT HEALTH



ANNUAL LESPEDEZA

Lespedeza striata

IDENTIFICATION TIPS

- ▶ Summer annual features small, inconspicuous purple flowers and three slender oval leaves per node, with pronounced and pinnate veins. Hairs on stems point down.
- ▶ Grows all summer and blooms from August through October.
- ▶ Prostrate in structure, it thrives in areas where turf is thin. It grows so close to the ground that it is rarely cut with a mower.

CONTROL TIPS

- ▶ In early spring, apply a pre-emergent herbicide labeled for lespedeza control.
- ▶ Maintain a dense, actively growing turf through proper mowing, fertilizing and watering practices.
- ▶ If you use a post-emergent herbicide, it is best to apply in late spring or early summer to allow the turfgrass a greater chance to fill in areas previously occupied by this weed.



KYLLINGA

Cyperus brevifolius

IDENTIFICATION TIPS

- ▶ Dark-green, narrow, ridged leaves have a shiny, grass-like appearance.
- ▶ Tightly bunched round seed heads sit on spikes.
- ▶ Flowers bloom from May to October on three-sided triangular stems.
- ▶ This perennial plant forms dense mats, and thrives with low mowing — preferring wet, poorly drained soils.

CONTROL TIPS

- ▶ Control soil moisture, because excessive moisture encourages growth and germination.
- ▶ Low, routine mowing heights reduce its persistence.
- ▶ Make multiple post-emergent applications of an arsonate herbicide like MSMA, or sulfonyleurea-type herbicides like halo-sulfuron or penoxsulam.

For more information regarding these and other turf weeds — and related control technologies and tips — please visit www.DowProvesIt.com or call 800/255-3726.

BROUGHT TO YOU BY  **Dow AgroSciences**

Dimension[®]
Specialty Herbicide

Gallery[®]
Specialty Herbicide

Snapshot[®]
Specialty Herbicide

 **Dow AgroSciences**



It takes courage to admit there's a problem.

Meet Frank. He's got what you'd call a "problem" with hand-weeding. Fortunately, there's Dimension[®], Gallery[®] and Snapshot[®] specialty herbicides from Dow AgroSciences. They give Frank the kind of group therapy he really needs by delivering serious control of the toughest weeds in lawn and landscape settings. So go ahead and skip the awkward meetings. Come learn more about the portfolio of products proven to help kick the hand-weeding habit at DowProvesIt.com.

www.DowProvesIt.com 800-255-3726

*Trademark of Dow AgroSciences LLC. State restrictions on the sale and use of Dimension specialty herbicide products and Snapshot apply. Consult the label before purchase or use for full details. Always read and follow label directions. [™]The swinging golfer logo is a registered trademark of PGA TOUR, Inc. ©2010 Dow AgroSciences LLC T38-000-018 (2/10) BR 010-60665 DATOTURF9072

OFFICIAL
CHEMISTRY
COMPANY



P R O V E N S O L U T I O N S



BEST PRACTICES

BRUCE WILSON

The author is a partner with the Wilson-Oyler Group consultancy. Visit www.wilson-oyler.com.

Optimize crew size

Among the frequently asked questions I receive is “What is the ideal crew size?” While on the surface it sounds like this should have a simple answer, it’s really quite complex. There are just as many factors favoring small crews as those favoring larger crews. Let’s take a look at six of the most common.

1. Job size. It’s nearly impossible to efficiently do a small job with a large crew. This is especially true of a route made up of small jobs. If a crew has to make four or five stops per day to service the route, things such as travel time, set-up time and loading time can eat into efficiency. The larger the crew, the more time is lost to non-revenue producing activities — making small crews more efficient on small jobs.

An exception might be if the small jobs were all in one industrial park, and the same crew could work numerous jobs simultaneously. Cost tracking is difficult, but should not be reason enough not to do it.

2. Route density. While every good manager strives to improve route density, it rarely is perfect. Four- to six-man crews can be efficient on large sites (one to three sites per day), as long as there aren’t long drives between jobs. Crew sizes of two to three people work well for mixed job size routes with varying job density.

3. Average hourly wage. The larger crew usually has a lower average hourly wage than a smaller crew, because a lower-paid crew offsets the crew leader’s higher wage. A simple example is a \$12/hr foreman with two \$9/hr laborers. This crew has an average hourly wage cost of \$10. Compare that to a \$14/hr foreman with five \$9/hr laborers, which creates an average hourly wage of \$9.83. The wage savings alone with the larger crew contributes 1.7% to the bottom line.

Understanding and managing average hourly

wage can be a significant factor in improving profitability, especially if combined with right-sizing crew to other factors.

4. Crew leader qualifications. While larger crews can have advantages of size and lower cost, they mean nothing if the crew leader cannot manage properly and crew members get in one another’s way. Large crews need good crew leaders, with leadership being the driving factor. Many crew leaders are the best workers — or in some cases, the person with the driver’s license. If this is the case, that person might be ineffective at managing five people and keeping them all operating efficiently.

With small crews, the job of leadership is important, but is much simpler: The hard-working crew leader’s personal impact is more significant.

5. Equipment availability and efficiency.

Smaller crews require a company to have more vehicles on the road. We all know that has a higher cost and greater liability exposure. Large crew trucks may have a higher initial cost, and big trailers might be harder to drive safely — but long-term, the cost is lower because you can derive higher revenue per hour per vehicle and dollar of capital investment.

6. Job requirements. A larger job that might be more efficiently serviced by a large crew requires someone on-site daily. Perhaps the client wants the whole job mowed in one day, requiring a large crew. In these and similar situations, you may find that individual job requirements dictate crew size.

Crew right-sizing and route optimization can be a big profit driver for a landscape maintenance company. The right crew size for a company is probably a combination of large and small routes and crew sizes. Based on the above, the best practice is to understand and manage the variables and to plan out the most efficient and effective combination of factors in constructing your routes and crew sizes.

SNOW+ICE

GUIDE

Liquid saves the season

When salt supplies dried up, this Michigan contractor knew it was time to try something different — or suffer through another tough winter.

BY DANIEL WEISS



New sprayer models feature lightweight construction for reduced stress on the vehicle and in-cab controllers for convenient operation from inside the cab.

PHOTO COURTESY: BOMEX, A DIVISION OF TRINEX INTERNATIONAL

THE PROBLEMS OF THE WINTER of 2007-2008 were not going to be repeated, I promised myself, heading into this past snow and ice management season. As you may remember, in mid-season 2008, salt ran out. There was little warning, a few rumors, grumblings from vendors, but little clarity. Salt deliveries were on the way — yet, by about February (at least in Michigan), the salt was gone. First it slowed to a dribble, and then like the drying action of a bread-and-butter snow melt, it was just gone.

Here's what we heard in our market: There are two major deposits of salt in the United States, one stretching from northern Ohio into Michigan and the other in Louisiana and northeast Texas. Curiously, much of the salt in Michigan, where we offer services, is sold elsewhere, out of state. Barges travel down the Mississippi with grain and bring back salt. But because of record-high fuel prices and the big push to produce bio-fuels, grain that ordinarily would have been shipped south stayed in the Midwest to be turned into bio-fuel. Fewer barges going south empty helped push up the price of the salt coming back. Eventually the stores of salt available for transport ran out.

This wasn't a new development. It started the previous winter — with the economy in the dumper, a record snowfall in our region of the country and salt, when it was available, at previously

continued on page 41

PUT YOUR
RIGHT WING IN
PUT YOUR
RIGHT WING OUT
PUT YOUR
LEFT WING IN
AND MOVE
MORE SNOW ABOUT



Windrow Position



8' Retracted Straight Blade



10' Expanded Straight Blade



9' Scoop Mode



Financing Available

**WESTERN® WIDE-OUT™ EXPANDABLE-WING SNOWPLOW
MOVES MORE SNOW IN LESS TIME**



www.westernplows.com

continued from page 39
unimaginable high prices.

Yes, salt was occasionally available, but lines were long to get loaded. That winter, contractors showed up with fists of cash trying to outbid other contractors for salt. Complicating matters, the media took its time reporting on the salt shortage — so most customers hadn't heard of the shortage, and they didn't want excuses. They expected service. Consequently, we used a lot of very expensive bagged salt and paid dearly for the salt we could get our hands on.

Near the end of the 2007-2008 season, customers finally began to realize that salt was gone, especially when they noticed that city and county roads were left untreated. Suddenly, the availability of salt wasn't just a contractor problem. This realization helped us improve relations with customers, but some still didn't get it.

I didn't want to experience that again, so I began investigating liquid products for the 2008-2009 winter season. Admittedly, I was reluctant to



Liquid deicers are often a better option than salt.

change, and I began asking myself a lot of questions.

Could we make the change and be successful? Would it work? Would we be able to keep customers happy using liquids on their properties?

The liquid diet

That first season, we put liquids to the test. We didn't feel comfortable com-

pletely abandoning salt, so we kept a stock of both products to use. Now with two winters under our belts, we have a much better idea of what liquid can and can't do, and how it compares to salt.

Within a few winter events, we determined that the liquid did not work as well as we would have liked when additional precipitation covered it and temperatures remained cold. Keep in mind that preventing freezing and burning off snow or ice aren't the same thing. Also, preventing freezing doesn't mean the area that was treated won't be slippery — something we learned early last season when we were using just the liquid. By contrast, salt burns from the top down and continues working even when some additional precipitation covers it.

Our use of liquid ice melter did find a place in our treatment regimen, however. And it did have several pluses. For starters, we had an ample supply of the liquid ice melter all winter. Also, equipment was easier to operate and we could do more with smaller trucks. These factors combined to save us a lot of money, particularly when there was just a dusting of snow. Why spend more than you need to on salt when you only needed a little ice melter to burn it off?

All in all, we considered the switch to using liquids in some situations and on some properties to have been successful. Different snow or precipitation

Dynamic fluid		
	SALT	LIQUID (MAGNESIUM CHLORIDE)
advantage	<ul style="list-style-type: none"> » Works from the bottom up and top down » It melts and dries 	<ul style="list-style-type: none"> » Non-corrosive » Low price versus what you can charge » Can use smaller truck to spread more material » Works to below freezing » Ample supply » Equipment easier to operate
disadvantage	<ul style="list-style-type: none"> » Corrosive » High price/scarcity » Need larger truck for larger amounts » Works well to about 20°F » Equipment needs maintenance, washing 	<ul style="list-style-type: none"> » Works top down only (additional precipitation will cover) » Prevents freezing, but surface tends to refreeze » Slow to melt snow » Must plow more often and to lower depths

events usually call for different management strategies. On many events, we sent out trucks with both salt and liquid. One route was liquid and one route was salt, depending on the needs of our customers and the amount of freezing rain, ice or snow. We saved money on salt, and made money on the liquid, which was our goal when we began the season.

The 2009-2010 season was challenging and once again, we learned a lot. In the northern United States, low-pressure systems spin counterclockwise, taking moisture from ground level to the sky, then dumping it back down as precipitation. Because of the rotation and its usually slow track speed, Michigan had several long-lasting systems that would produce a half to a full inch of snow during a 12- to 24-hour period for several

We used a lot of very expensive bagged salt, and paid dearly for the salt we could get our hands on. (With liquid) equipment was easier to operate and we could do more with smaller trucks.

days in a row. Unfortunately, we had to turn to salt to keep up with this kind of storm system. Liquid would work to keep roadways from freezing, but they became snow-covered. With commercial contracts, depth of snow is often less important than if the roads are snow-covered at all. The liquid couldn't keep up. Even with the price of salt coming back down by 20%, it made for busy and expensive storms.

Will this treatment strategy work for you? It might be worth trying. **LM**

WEISS owns Elysian Design Group. Contact him at ElysianDesign@aol.com.

The lighter side

Fisher's new HT Series snowplow is designed to fit today's lighter half-ton 4WD pickup trucks for standard-duty commercial and institutional applications. The full-featured HT Series boasts many of the same features of larger Fisher plows, including Intensifire lights, the fast Minute Mount 2 on/off system and Fisher's original trip edge. It also incorporates a hydraulic scrape lock for clean scraping and back dragging. FisherPlows.com



Quiet power

Ariens' new AMP 24 Sno-Thro is an all-electric two-stage snow thrower with a 24-in. clearing width. The machine runs 45 to 60 minutes on a single charge depending on snow conditions, and provides a quieter alternative to traditional gas-powered snow throwers. It's powered by a 4-hp brushless

DC electric motor and energized by two 48-volt AGM Valve Regulated battery packs. Starting the machine is as simple as turning the key and pulling the PTO switch, which instantly starts the electric motor. With no gas engine, the unit reduces service requirements, fuel costs and special storage requirements during the summer months. Ariens.com

Hydraulic power

Available in either electric/hydraulic or central hydraulic powered configurations, **Hiniker's** new 1032 Series 10-ft. plows are designed for use with trucks such as GM 4500/5500 series, the Ford F-450 and F-550, and the Dodge 4500/5500 series. The 32-in.-tall moldboard uses a dent-resistant, corrosion-free plowing surface made of low-friction HDPE polyethylene. A top-mounted extruded polyethylene snow deflector is included as standard equipment. The trip hinges have been designed to eliminate any pinch points, assuring a full return after tripping. Hiniker.com



continued on page 44

BLIZZARD. COFFEE. BLIZZARD®.

[repeat]



Unmatched innovation, productivity and profitability.

blizzardplows.com



financing available

continued from page 42

Slick success

Available in two sizes (8 ft., 2 in. and 9 ft., 2 in.), The **Boss**' new Poly Power-V XT Plow features a super-slick poly surface that lets snow easily slide off the blade, saving on fuel costs and minimizing wear and tear on the vehicle drivetrain. The multi-position plow also features a 37-in. flared blade wing that improves snow discharge. Among its many other features are the SmartHitch 2 Attachment System and the SmartTouch 2 Handheld Control. BossPlow.com



Let it blow

Two new models of front-mounted snowblower implements, featuring a 49- or 62-in. cutting width, are now available for Bobcat compact tractor models CT120 to CT235. A 72-in. cutting width model for the CT225 to CT450 will be available at a later date. The discharge chute on the snowblower rotates hydraulically, so the operator can easily redirect snow as needed. To operate a front-mounted snowblower, the tractor must be equipped with a mid-PTO, loader joystick and control valve. The snowblower requires a lift kit and PTO kit to mount to the tractor. BobcatDealer.com

Heated wipers

Now made of silicone, **W.N. Miller Co.**'s newly redesigned Everblades heated wipers are more robust and provide a streak-free wipe — regardless of whether they're in heat mode. The redesigned squeegee profile also offers better durability, life and functionality to enhance winter driving vision, safety and productivity. Everblades.com

Rugged performance

The new 9 ft. **Blizzard** 9000HD straight blade snow plow features a flared moldboard that rolls snow far ahead and to the side, an aggressive cutting edge angle, optimized blade curl, and the fast, hydraulically powered Power Hitch 2 mounting system. BlizzardPlows.com



Full line

The Ice Control Sprayers line from **Turbo Technologies** ranges in size from 30 gal. for ATVs to 1,600 gal., truck-mounted units. It also offers both electric pumps for quiet operation and gasoline-powered engines and pumps. Integrated liquid transfer is standard on gasoline-powered units. Remote operated booms for up to three-lane coverage are available, as well as multi-nozzle turret booms and ice control sprayers on over-the-road trailers. Units can be equipped with spray guns for sidewalk and step applications. IceControlSprayers.com

Clean sweep

Attachable to most brand-name snowplows, **SnowEx**'s new SPB-072 and SPB-090 Snowbrooms are capable of clearing snow and slush without damaging concrete, sod or sprinkler heads. This makes them an ideal choice for use on decorative concrete, sidewalks and paths. They also add versatility to mid- and full-sized pickup trucks by allowing them to remove sand, salt and other debris after the winter season. Because the patented Snowbrooms take advantage of existing equipment, they contain no engines, pulleys, sprockets, belts, chains or any other moving parts. Trynexfactory.com



continued on page 46

HIGH-PERFORMANCE COMMERCIAL PLOWS

HOMEOWNER



HINIKER



TRIP-EDGE
C-PLOWS



TRIP-EDGE **V-PLOWS**

STRENGTH & PERFORMANCE

Hiniker offers a *comprehensive line* of *professional grade* snowplows to meet the demands of the toughest conditions and snowplow operations.

V-PLOWS: Trip-edge design gives smooth operation and effective protection with a nine-inch high pivot point. Double acting cylinders provide positive moldboard position control.

C-PLOWS: Get the heavy-duty performance of the Hiniker trip-edge conventional plow plus the added versatility of a high performance backdrag plow. An amazing time-saver in driveways, parking lots and loading docks.

SCOOP PLOWS: High capacity concave shape captures snow to efficiently clear lots and parking areas. Angles left or right for conventional plowing.

CONVENTIONAL PLOWS: 30 inch tall high-curvature blades roll deep snow off quickly and efficiently. Commercial plowers will appreciate the extra strength and efficient design.

HOMEOWNER PLOWS: Low-maintenance poly moldboard surface reduces friction, never needs painting. 6 vertical and 2 diagonal ribs provide strength and support.

The *Quick Hitch* mounting system is interchangeable with all Hiniker snowplow models, adding versatility to your snowplow fleet.



TRIP-EDGE
SCOOP PLOWS



TRIP-EDGE
CONVENTIONAL PLOWS



FULL-TRIP
CONVENTIONAL PLOWS



FULL-TRIP
HOMEOWNER PLOWS

HINIKER

HINIKER COMPANY
Mankato, MN • 1-800-433-5620 • www.hiniker.com



continued from page 44

Brine converter

The ABS-800 from **GVM Snow Equipment** will convert standard rock salt to a liquid brine for anti-icing or prewetting at the spinner, resulting in more efficient results for snow and ice management practices. The brine maker has the capability of making up to 3,000 gal. of brine per hour. The pump station is enclosed in a poly enclosure, with plenty of room to store all necessary hoses required to manufacture the brine. Voltage requirements to run the pump station are 115 volts, making this system portable if needed. *SnowEquipmentSales.com*



**SECTIONAL
SNO-PLOW™**

By
ARCTIC®
Snow & Ice Control
Products

"THE ONLY PLOW YOU'LL EVER NEED."™

www.sectionalplow.com

Call us at 888-2-ICE-SNO

101 North Euclid Avenue • Bradley, IL 60915



Even distribution

With a 32-in. height and 75-degree attack angle, **Meyer's** new Lot Pro delivers quick clearing performance and quality back dragging. Supporting the tall, aggressive moldboard is a redesigned "black iron" consisting of a heavy-walled, tubular-steel A-frame and push bar. This improved design has been simplified to create a stronger plow at key pressure zones and more evenly distributes the load. It's also interchangeable with the Meyer Super V and Diamond Edge bottom-trip plow. In addition, the modular EZ-Mount Plus system attaches or detaches from the truck quickly and easily. *MeyerProducts.com*

Safe and secure

The exclusive Security Guard Anti-theft System provides a safe and secure way to electronically "lock" Western snowplows, providing a deterrent from theft or non-permitted use. The system works by electronically synchronizing the snowplow control and snowplow's electrical system. When activated, the system disables the electrical controls and renders the plow inoperable to unauthorized users. It's currently available on select Western snowplow models. *WesternPlows.com*

continued on page 48



**“Meyer[®], there is a difference.
You have my word on it.”**

Andrew L. Outcalt

Andrew L. Outcalt
President, Meyer Products LLC

When you think of the best, it's time to think "Meyer." We recently completed a company wide transformation that included redesigning all our products, investing millions of dollars in new manufacturing equipment, and hiring a new management team.

Backed with an industry-leading 3/5-year warranty, our plows will minimize your downtime. You'll push more snow faster while leaving the job site clearer. And mounting systems will now take seconds to use and are interchangeable with all new moldboards.

I invite you to "experience the difference" in our **Reliability**, **Performance** and **Ease of Use**.

For more information go to www.meyerproducts.com

continued from page 46

Dual edges

Pro-Tech's Switchblade is a reversible Sno Pusher for loaders, backhoes and skid steers that has both a rubber cutting edge and a steel cutting edge. The rubber edge is designed for wet, heavy snow conditions where the rubber can squeegee the surface clean. The steel side is ideal for breaking up hard packed snow conditions and now comes standard with the patented IST steel trip system. Like all of Pro-Tech's products, the Switchblade is engineered for simplicity and reliability. SnoPusher.com



Salting options

Morton Salt's line of professional-grade ice melting solutions includes the economical Safe-T-Salt, the fast-acting Ice Melter Blend, the low-temperature Calcium Chloride Ice Melter, the environmentally friendly Eco-Safe Blend (pictured) and the high-visibility Ice Melter Blend with Fast-Acting Blue Crystals. MortonSalt.com



Mix it up

Fecon's new CM2000 Salt Mixing System combines de-icing, liquid-based agents with bulk salt or sand solutions to use as pre-treatment before snowstorms. It features a 170-hp John Deere engine and mixes up to 240 tons per hour. The unit includes a feed hopper, a primary mixing chamber and an automated continuous flow additive injection metering system. An optional stainless steel body is also available. Fecon.com



PERFORMANCE YOU CAN TAKE TO THE BANK!

A penny saved is a penny earned. But how does saving up to 680,000 pennies – \$6,800 – per vehicle/per year sound for your operation?

SAVES Maintenance

No pulleys, sprockets, belts or chains.

SAVES Material

Independently controlled auger and spinner speeds.

SAVES Manpower

Patented auger drive systems ensure continuous flow.

START SAVING TODAY! Visit your local dealer to get more information on limited-time, free product offers from SnowEx.

SnowEx
LEADERS IN ICE CONTROL

1-800-SALTERS • snowexproducts.com

Visit us in booth #825 at the SIMA show.



UTILITY



TAILGATE



PRO



V-MAXX



REPLACEABLE TAILGATE



DE-ICING SPRAYERS



ACCUSPRAY



Electric drive

SnowDogg plows from **Buyers Products** include a stainless-steel, corrosion-free moldboard, heavy-duty covered power unit and quick mount system. The plows are available for light-duty trucks up through heavy-duty commercial/municipal applications. A full line of SaltDogg spreaders completes the plow truck. From 4-cu.-ft. tailgate spreaders to 15-yd. municipal spreaders, there's a SaltDogg for a complete range of applications and preferences. The new electric-drive stainless steel undertailgate and electric-drive stainless steel hopper spreaders are popular choices. SnowDoggPlows.com / SaltDogg.com



TRIPLE THREAT.

NOTHING'S TOUGHER, SMARTER OR FASTER. Introducing the **NEW Poly Power-V XT**: a rock-solid combination of professional-grade toughness, Power-V versatility and super-slick poly efficiency. Not to mention 37" tall flared blade wings that throw snow higher and farther than any other plow. Bottom line? There isn't a tougher, smarter or faster plow on the market today. Simple as 1-2-3.

To learn more about THE BOSS **XT** lineup, including the all-new Poly Power-V **XT**, visit bossXTplow.com



PRO-TECH GIVES YOU MORE

GROWTH OPPORTUNITY

'We were hired by another place because of the reputation we developed using Sno Pushers.'

-Chris James
Chris James Landscaping, Waldwick, NJ

EFFICIENCY GAINS

'One Sno Pusher saves us the equivalent of five trucks.'

-Darin Campbell
Greenthumb Lawncare, Wichita, KS

TIME TESTED QUALITY

'Sno Pushers are far superior to the competition.'

-Lawrence Neville
Royal Turf Chemical Lawn Care, Stirling, NJ

Visit our website to see our vast product line and to find your local distributor.



PRO-TECH[®]
MANUFACTURING & DISTRIBUTION



www.snopusher.com • 888-PUSH-SNO

Legislative Day On The Hill

July 18 – July 20

2010



REGISTER ONLINE

Register Today!

[LandcareNetwork.org/
cms/lldr](http://LandcareNetwork.org/cms/lldr)



Renewal & Remembrance

July 19, 2010

Arlington National
Cemetery



Build Awareness

Plan now to join other green industry professionals to increase your knowledge about legislative issues that affect your rights and privileges and to participate directly in the political process.

HONOR AMERICA'S VETERANS

Reaffirm your pride and patriotism as you join other PLANET member volunteers in dedicating manpower and equipment to enhance the beauty of Arlington National Cemetery.

THANK YOU TO OUR 2010 SPONSORS

PLATINUM SPONSORS:



GOLD SPONSORS:



SILVER SPONSORS:



MEDIA SPONSOR:



HAT SPONSOR:



Registration Deadline:
July 2, 2010



ACUTABOVE

GREEN INDUSTRY MAINTENANCE LEADERS » BY DAN JACOBS

It's a matter of accountability. "Our people have a clear understanding of what they are supposed to deliver and are measured on that," says **Martin Cleary**, owner along with his brother Mike, of Cleary Brothers Landscape, Danville, CA. The Clearys have built a successful enterprise by rewarding decision makers and letting them make decisions that affect their rewards. "They are given power to make decisions and also make mistakes," Martin Cleary says. "As an owner, I am always available for council but I expect my people to take action. I have high expectations, but I don't expect absolute perfection."



Martin Cleary runs one of the largest landscaping companies in California.

INSIDE INFO

Company: Cleary Brothers Landscape

Headquarters: Danville, CA

Year founded: 1987

Employees: 165 full-time

Annual revenue: \$10 million

Services offered: Landscape construction, landscape maintenance, arborist services

Key to being a maintenance leader: Our key has been the same since day one. Do great work and love our customer. We make every effort to provide a top-level experience for our customers. We don't accept shoddy work. Every person in our company is trained to respect our customers in every action that we take. This is a primary part of our culture. All of our employees consider themselves as professionals and take pride in the work that they do. We have great people on staff. Great people attract great people. Great people also attract great customers.

tion systems, pest control choices, sustainable landscaping processes, management information systems, and compliance. Without a strong staff, this is a huge challenge to the landscape contractor.

» **Downward Push.** Pricing pressure is going to continue to get worse for the next two years.

TOP OPPORTUNITIES

» **Water Management.** In many parts of the country water is in short supply. Being expert in managing that resource is a huge opportunity for the landscape contractor. Getting educated through trade groups and vendors on technology and techniques is a key to success.

» **Renovation Work.** In order to keep property values up in a tough market, the property has to look better than the competition. Renovation will always be an opportunity, particularly in the smaller commercial arena.

» **The Proper Attitude.** Being positive in a negative world. People, it's a buyers market right now for top talent. While others are putting the brakes on, this is the time to recruit.

TOP TRENDS

» **Sustainability.** There is a real movement toward sustainable and responsible landscaping. Our industry has matured and so have our customers. Commercial customers expect to deal with professional firms.

» **Mutual Growth.** Property owners expect more from their landscaper than just horticultural care. They expect a partner, a company that will give them support and input that helps to meet their goals.

» **Accountability.** We don't micromanage our managers. They are given power to make decisions and also make mistakes. When mistakes are made I only expect action to fix the mistake.

TOP OBSTACLES

» **A Down Economy.** Most landscape companies are small and are going to have a hard time competing with the larger firms. If a company has sales under \$5 million overhead is going to be very difficult to dilute. To thrive in this economy, the landscaper has to have people focused on sales, marketing, production, customer service, and accounting.

» **Expertise.** To be on top, the landscaper has to be expert in a variety of topics: advanced irriga-

BROUGHT TO YOU BY



Put your business here.

**TAKE YOUR TURN ON THE NEW PRO-TURN™ 200
AND TAKE YOUR BUSINESS WHERE IT BELONGS.**

Get more machine for your dollar. The New Pro-Turn™ 200 Series means less maintenance, less downtime and improved operator productivity—all at a great price. We could tell you more but it wouldn't matter. You've got to experience the revolutionary Pro-Turn™ 200 Series for yourself. So visit your Gravely dealer today and put your business in the driver's seat.



WE KEEP YOU CUTTING®

WWW.GRAVELY.COM



WWW.YOUTUBE.COM/GRAVELYCHANNEL

Check out what cutters and dealers had to say after they took their turn on the Pro-Turn™ 200 at the 2009 GIE+EXPO.



Mac vs. PC: I choose Door No. 3

Even though my first computer was an Apple IIc, I've been a Windows guy for years. I'm comfortable on a PC. My Dell Latitude 630 has been a great little laptop for me. But recently,

I was given a 15-in. MacBook Pro, and I have to admit, I'm impressed. The real question, yet to be answered, is: Will I switch?

Judging from all of the commercials, you could easily guess that Windows users and Mac users don't see eye to eye. You might even have the impression that Windows users are either nerds or the All-America Average Joes who love their computers. Conversely, Mac users are either hip twenty-somethings or out-of-touch elitists.

It's easy to see the marketing machines at both companies running at full tilt. It's somewhat more difficult to cut through the noise and get a sense of which system works better.

For me, a computer has to fit my needs. It's just a tool, a means to an end. It's not a fashion or political statement. Getting things done is the key. My daily workload consists of software development, email, social media, finance and, of course, article writing. My computer is also my launching point to the most important tool available to me: the

Internet. It's interesting that, with the exception of social media, those tasks haven't changed for me for more than 15 years. I think it's safe to say that, independent of my computer's operating system, I'll be doing these same tasks for many years to come.

I like my Windows PC because I'm comfortable with it. I understand how things work. The standard keystrokes have become second nature to me. I have all of the software tools I need to get things done, both quickly and efficiently. Unlike the message I hear from Apple commercials, I run Windows Vista and like it. It just works.

Now that I've had a chance to play with my new MacBook Pro, however, there are several things that are really nice. First, the multi-touch track pad works like a dream. Using two fingers to scroll, three fingers to move top or bottom, and four fingers to view all of my running applications is really nice. The solid, glossy, smooth laptop hardware definitely lives up to the Apple hype. And surprisingly enough, I'm finding Mac versions of my favorite software. From a developer's perspective, it's also nice to have access to the underlying Unix operating system. It's been a bit of a learning curve understanding where things are and how to be efficient, but certainly manageable.

So, do I now consider myself a Mac guy? It's interesting. Through learning more about the Mac, I've come to realize that my ability to transition from Windows to Mac has less to do with the features or functionality of either system. It has everything to do with the fact that my computing life is now solidly out in the Internet. Most of my software tools reside on Web sites I can get to from either a Windows PC or a Mac. And while I like both computers, it has become clear to me that they both equally provide access to the one tool I can't do without: the Internet. I suspect that in the years to come, computers will be seen as just a gateway to the Internet.

As for Windows vs. Mac: I choose the Internet.



It's easy to see the **marketing machines** at both companies **running at full tilt**. It's somewhat more difficult to cut through the noise and get a sense of **which system works better**.

“A PERFECT GAME IS RARE.
PERFECT TURF SHOULD BE ROUTINE.”

— Andrew Adams
Capital Turf Management
Willow Grove, PA



Make a statement with DuPont™ Acelepryn® insecticide.

Evolve your business with DuPont™ Acelepryn®, the latest advancement in grub control. One application provides unparalleled performance against every turf-damaging white grub species as well as key surface feeders. The Acelepryn® Application Advantage delivers timing that fits every grub preventative treatment program. Acelepryn® also provides effective control of key insect pests infesting landscape ornamentals. And, Acelepryn® is the first and only grub control product to be granted reduced-risk status by the U.S. EPA for application to turfgrass. Customers will appreciate the excellent environmental profile and the exceptional performance of Acelepryn®, while you'll benefit from a reduced number of costly callbacks. **DuPont™ Acelepryn®. Start an evolution.**



The miracles of science™

Make money with
matrix[®]
pansy



Matrix[®] pansy makes more blooms for more impact – count on season-long color in your plantings. Turn to Ball for fast, easy and profitable landscape color solutions!

Request your free Landscape Color Solutions catalog with poster and photo CD at **balllandscape.com**.

800 879-BALL





TOURING • THE *trials*

THE CALIFORNIA SPRING TRIALS SHOWED OFF NEW VARIETIES AND PLANT TRENDS.

BY JAMIE J. GOOCH

FROM GILROY TO ENCINITAS, and all the stops in between, the new and yet-to-be-released cultivars were on display for a week in April during the 2010 California Spring Trials. Growers, retailers and landscapers who want to know what's new and what's next attend the annual event. This year's displays didn't disappoint.

In what is perhaps a sign of an improving economy, visitor traffic reports were up this year, compared to last year's trials, despite the timing of the 2010 event.

"We were all very surprised by the turnout, especially since the event was extra late this year (due to how Easter fell on the calendar) and most growers were deeply involved in spring crops already," says Dean Bemis, broker account manager for Syngenta Flowers.

Expanding color ranges

"There was, as always, a plethora of color on display," says Steve Carver of the trials. Carver is manager, Technical Education at OFA — An Association of Floriculture Professionals. He and his OFA companions made 13 stops along the trial trail this year. "Everyone is trying to push the border on the color range of their product lines. This year, the stand-out for me was the black petunia."

"The Ball FloraPlant Black Velvet Petunia — the world's only black petunia — certainly wowed at this year's trials," says Jennifer Neujahr, product marketing manager for PanAmerican Seed, a Ball Horticultural brand. "Black is the perfect complement to other colors and can create drama in the landscape and in mixed containers."

That drama stems from the contrast between light and dark, which was a popular theme in this year's displays.

"Contrasting colors seemed to make a bigger impression this year: blue set off by orange, red set off by green or yellow," says Bemis. "Using contrasting colors of any kind was of great interest. It's an economical way to

A rainbow of colors greeted visitors to Goldsmith Seeds/Syngenta Flowers' trials in Gilroy, CA.

PROUD SPONSOR

Ball®

PHOTO COURTESY: SYNGENTA FLOWERS



BALL VARIETY FOCUS: MATRIX® PANSIES

It's never too early to plan for cool-season color. Matrix® Pansies are known for their superior holdability, large flowers, and outstandingly uniform colors and blends. Strong stems hold large and thick flowers without stretching; less stretching means greater longevity in the landscape. Matrix ships well, and landscape contractors experience less spoilage and better profitability. Pre-book Matrix Pansies for your cool-season landscapes. For more information, visit www.BallLandscape.com.

make a big impact as fewer plants can be used but they 'pop' and are very striking."

What landscapers learned

In addition to seeing new varieties, landscapers who attended this year's trials were able to see what the industry is doing to promote sustainability, pick up marketing ideas, and learn how to better maintain the plants they install for clients.

"What's exciting about Spring Trials is the inspiration it provides to all attendees," says Faith Savage, retail account manager for Syngenta Flowers. "That certainly holds true for landscapers and the growers who serve them. At Spring Trials, it's our mission to create landscape displays that inspire and motivate."

In addition to inspiration, landscapers at the trials were able to determine what new plants they should order this year for maximum impact.

"The landscape market segment wanted to see cultivars that were not necessarily the least expensive on a

per plant basis, but that could fill in a big space so the number of plants per bed was reduced," says Bemis. "TigerEye rudbeckia, Volumnia begonia, and Xtreme impatiens would be good examples from our seed assortment. Believe it or not, the Picobella milliflora petunia is very spreading and thus falls into this category."

Carver says landscapers should attend the trials to get the big picture of the plant options that are available.

"Landscape design and maintenance is based on sound science, but it is art that composes its heart and soul," he says. "If an artist would not attempt to paint a portrait or a landscape mural without a full pallet of color at his disposal,

For more information on the 2010 trials, including complete interviews and dozens of pictures, visit www.landscapemanagement.net/livescapes/.



Black was the new black at Ball Horticultural Company's trials in Santa Paula, CA.

why would a landscape professional attempt to 'paint' or maintain a living landscape without at least knowing the pallet options at their disposal? The California Spring Trials provides landscaping professionals with the ideas and materials to keep properties they design and manage fresh, fashionable ... and profitable." 🌿

Gooch is a freelance writer based in Northeast Ohio. Contact him at jamie@goochandgooch.com.

PHOTO COURTESY: STEVE CARVER, OFA — AN ASSOCIATION OF FLORICULTURE PROFESSIONALS



WE HAVE THE WIDEST SELECTION OF LED SOLUTIONS FOR WHATEVER DESIGN YOU HAVE IN MIND.

Leading the industry with the most advanced LED technology, Vista offers a longer lasting solid-state design available in copper, brass, aluminum, stainless steel and composite enclosures to meet all your project needs.

Call **800-766-8478** for a **FREE** 12 Volt Series brochure that details everything.



VISTA PROFESSIONAL OUTDOOR LIGHTING

www.vistapro.com



EarthWay
SPRAYPRO

S25 Ground Driven Push Sprayer

Use the S25 for spraying pesticides, herbicides, fertilizers around the home and office. Use it on lawns, driveways and paths. NO GAS, NO BATTERIES, NO PROBLEM...

For information call 800-294-0671 or visit www.earthway.com



Well red

Benary's new *Gaillardia x grandiflora* 'Arizona Red Shades' is the first red gaillardia from seed, according to the company. This FastraX perennial flowers the first year without vernalization, and offers an excellent branching habit. Its masses of flowers bloom throughout the summer, and offer impact in beds, pots or mixed containers. Benary.com

Variiegated beauty

Twist of Lime Variiegated Abelia from Garden Debut has bright yellow leaves with green centers when young, maturing later in the season to ivory and green. It produces blooms of fragrant, white-tinged-pink clusters of trumpet-shaped flowers (up to 5/8 in. long), which appear from late spring to fall. Dusty pink "ruffs" of sepals last after the petals are gone. This Abelia hybrid is a rounded, spreading, multi-stemmed shrub in the honeysuckle family. It typically grows to a mature height of about 4½ ft., especially in Zones 6-10. GardenDebut.com



Plum delicious

The purple leaves on Terra Nova Nurseries' Heuchera 'Sugar Plum' make a full mound of evergreen foliage. Silvery pink flowers rise 26 in. above the soil and frequently rebloom. Hardy in Zones 4-9, this perennial coral bell plant likes moist, well-drained soil. It thrives in mixed beds, borders, understory, containers and entryways. TerraNovaNurseries.com

Z-SPRAY VS. the COMPETITION

	Z-SPRAY	Competitor A	Competitor B
True Zero Turn Maneuverability	✓	✗	✗
By-Pass Agitation	✓	✗	✗
All Stainless Steel Chassis	✓	✗	✗
220 LB Hopper Capacity	✓	✗	✗
Optional Auxiliary Tank	✓	✗	✗
50' Hose Reel for Spot Spraying	✓	✗	✗
G.P.S. Speedometer	✓	✗	✗
8 m.p.h. Transport Speed	✓	✗	✗
3 Section Independent Boom	✓	✗	✗
Hydraulic Drive Hopper	✓	✗	✗
3' to 25' Variable Spread Width	✓	✗	✗
4.0 GPM Pump	✓	✗	✗
Standard 18 Gallon Spray Capacity	✓	✗	✗
Up to 1 Gallon per 1000 capacity	✓	✗	✗
Air Injection Low Drift Nozzles	✓	✗	✗
18" Front Tires	✓	✗	✗
20" Rear Tires	✓	✗	✗
18 HP Electric Start Engine	✓	✗	✗
Locking Caster System	✓	✗	✗
5 Gallon Gas Tank	✓	✗	✗

Z-Max & Intermediate
50 on Z-Max
not applicable
not applicable

L.T. Rich Products
 Call us at: (877) 482-2040
 or visit us at: www.zspray.com

Why choose anything else?

weedalert.com

The Turf Professional's Free On-line Source for Weed ID and IPM Control Recommendations

- Weed ID Photos
- Regional Alerts
- Control Options
- Turf School Links

TEST YOUR WEED IQ!

WEEKLY CONTEST-

Correct ID Can Win This Magic Mug

With Disappearing Ink

An Industry Service From

An Employee-Owned Company



CEO Burt Sperber explains the ValleyCrest way as part of a site visit to the company's Las Vegas offices.

EXECUTIVE

It's a sustainable world; we're just living in it.

BY **DANIEL G. JACOBS** MANAGING EDITOR

Sustainability.

Get used to the word. You'll be hearing it a lot more. In fact, if you haven't already, it's probably because you haven't been paying attention.

Whether it's developing a sustainable business model or adopting "more green" business practices, "sustainability" was a theme thread throughout the Professional Landcare Network's (PLANET's) Executive Forum held in Las Vegas in February.

It might seem ironic to hold a conference dealing with sustainability in a city known for excess, but presenters repeated the theme throughout the event. And the event's 270 attendees, including 70 first-timers, were presented with a wealth of information from Green Industry veterans, consultants and a well-regarded economist.

A tour of the top

The folks of ValleyCrest Landscape Cos. do a lot of things well. Perhaps most important is founder, chairman and CEO Burt Sperber's ability to adapt to fit the changing needs of clients. And that hasn't changed in the company's 60-year history.

"Burt doesn't do anything small," says Tom Donnelly, president of ValleyCrest Landscape Development, a division of ValleyCrest Cos., perfectly describing the site visit hosted by the company's Las Vegas office.

With nearly \$1 billion in revenue in 2009 and almost 10,000 employees in 112 offices, ValleyCrest gave Executive Forum attendees an insider's glimpse of one of the Green Industry's largest operations. Those who participated in the facility tour got to hear about how the company continues to evolve. ValleyCrest has embraced the sustainable movement, examining its supply chain and business practices, as well as the expected outcomes.

"We're a little behind the curve," explains Kelly Duke, ValleyCrest's vice president of pre-construction. Duke says sustainability is achieved when the company meets its environmental, social and economic goals.

One concern many people have about sustainability is the perceived expense associated with it, but Duke argues that "sustainable practices need not be a cost."



AUTOMATE YOUR SUCCESS

with **GroundsKeeper Pro** business software

Organize your business better with **GroundsKeeper Pro** business software. It's specially designed for the lawncare and landscaping industry, easy to use and affordable...

FEATURES INCLUDE:

- Time & Materials
- Estimating
- Scheduling
- Optional credit card processing
- Income & Expense Reporting
- Contracts
- Routing
- Billing



JUST \$399

SAVE THOUSANDS OVER SIMILAR PROGRAMS

FREE TRIAL

ADKAD TECHNOLOGIES / 1.800.586.4683 / WWW.ADKAD.COM/LM.HTM

FORUM

More and more customers are asking to see documentation of companies sustainable practices. If an organization can't prove its sustainable approach, it might never get the job.

Before making any move, ValleyCrest does benchmarking for the current practice. Next comes a cost/benefit assessment. Then, realistic goals are created.

Economic outlook

Economic Futurist Jeff Thredgold offered Executive Forum attendees his rundown of the economic outlook. And in his words, things are looking up.

"We have endured the longest, deepest, most costly, most painful, the most pervasive recession in our lives," Thredgold says, "But we have returned to growth, and that will pay dividends in your industry."

According to Thredgold, there are seven critical industries to the U.S. and world economies: technology, transportation, telecommunications, financial services, energy, entertainment and biomedicine. There also are three guaranteed growth industries: healthcare, financial planning and leisure/entertainment.

Looking ahead

"Change is inevitable; growth is optional," says Jim McCutcheon, CEO and partner with Atlanta-based High-Grove Partners.

McCutcheon chaired PLANET's Crystal Ball Committee, which this year focused its efforts on sustainability. The result was the 29th Crystal Ball Report, "Green Industry Economics: Innovating Toward a Sustainable and Profitable Future," penned by *Landscape Management* Editor-at-Large Ron Hall.

The question for Green Industry

business owners is whether they will embrace change or get run over by it.

It doesn't have to be difficult, and you don't have to work from scratch," McCutcheon says. "I'm a strong believer in R&D — rob and duplicate."

To order a copy of PLANET's Crystal Ball Report #29, visit the *LM* bookstore at: <http://shop.landscapemanagement.net/shop.php>. **LM**



As a contractor, you work hard for your money... let TimeScope work equally as hard to help you keep your money. TimeScope will help your firm capture the reality of your largest expense...LABOR. By simply scanning barcodes, your crews will no longer hand in paperwork...it's all automated. Join over 6,000 users and get back in the game with TimeScope!



"The more companies that know their costs, the better for the industry. Your system can really help the industry with that problem."

- Jim Schwants,
President Acres Group,
Wauconda, IL

Modeco Systems LLC

Call Today! 866.677.8184

www.modecosystems.com

WEB EXTRA

To get Jim McCutcheon's 10 quick-start goals and the five reasons sustainability programs fail, visit the *LM* Extras section of *Landscape Management's* Web site at www.landscapemanagement.net.

CLASSIFIED SHOWCASE

ADVERTISING INFORMATION

Call Kelli Velasquez at
216-706-3767,
Fax: 253-484-3080,
E-mail:
kvelasquez@questex.com



Payment must be received by the classified closing date. We accept Visa, MasterCard, and American Express.

Mail LM Box # replies to:

Landscape Management Classifieds, LM Box # _____
306 W. Michigan St., Suite 200
Duluth, MN 55802

(please include LM Box # in address)

Every month the Classified Showcase offers an up-to-date section of the products and services you're looking for. **Don't miss an issue!**

BUSINESS OPPORTUNITIES

Professional Business Consultants
PBC
Merger & Acquisition Specialists

WANT TO BUY OR SELL A BUSINESS?

Professional Business Consultants can obtain purchase offers from numerous qualified potential buyers without disclosing your identity. There is no cost for this as Consultant's fee is paid by the buyer. This is a **FREE APPRAISAL** of your business.

If you are looking to grow or diversify through acquisition, we have companies available in **Lawn Care, Grounds Maintenance, Pest Control and Landscape Installation** all over the U.S. and Canada.

182 Homestead Avenue, Rehoboth, MA 02769
708-744-6715 • Fax 508-252-4447
E-mail pbcmello1@aol.com

SELL MORE LANDSCAPES & JOBS



Two **NEW** Profit Centers - 50%+
Two **NEW** Revenue Streams
Two **NEW** Customer Bases
A Simple, Easy Add-On Service
Buy Factory Direct - Wholesale
NO PAYMENTS & INTEREST
FOR 90 DAYS
We **FUND** Your Installs
1-800-334-9005
www.allprogreens.com/training

FREE DVD & TRAINING
SYNTHETIC LAWNS

EARN BIG
With Landscape Lighting



- Great Add-On Sale
- Enhance Your Projects
- Penetrate Affluent Households

WE CAN TEACH YOU TO DO LANDSCAPE LIGHTING THE RIGHT WAY!

Training ~ Support ~ Products
Call For Information
1.800.687.9551
www.nitetimedecor.com



SELL MORE LANDSCAPES & JOBS



Two **NEW** Profit Centers - 50%+
Two **NEW** Revenue Streams
Two **NEW** Customer Bases
A Simple, Easy Add-On Service
Buy Factory Direct - Wholesale
NO PAYMENTS & INTEREST
FOR 90 DAYS
We **FUND** Your Installs
1-800-334-9005
www.allprogreens.com/training

FREE DVD & TRAINING
SYNTHETIC GOLF GREENS

Snow, Lot Sweeping, & Landscape Contracts
Join the affiliation that works for YOU.
Contractors needed throughout the US.
Sign up today www.agmgus.com.
EXPERIENCE THE AGMG DIFFERENCE.

FOR SALE

Maryland based lawn maintenance company
100% commercial providing lawn maintenance, installations, and snow removal.
1 million annual gross sales.
Includes all equipment.
(301) 725-4956 (301) 725-0274 fax

PLACE YOUR CLASSIFIED AD TODAY TO REACH THOUSANDS OF INDUSTRY PROFESSIONALS!

Landscape Management

Visit us **ONLINE**



www.landscapemanagement.net

Incorporate
for as little as **\$99**

Visit www.incorporate.com
or call 800-616-0216

THE **COMPANY** CORPORATION®

INCORPORATING WHAT'S RIGHT FOR YOU

Use color to get the attention your ad deserves!

HELP WANTED

FLORASEARCH, INC.

In our third decade of performing confidential key employee searches for the landscape/horticulture industry and allied trades worldwide.

Retained basis only.

Candidate contact welcome, confidential and always FREE.

1740 Lake Markham Road
Sanford, FL 32771

407-320-8177 ♦ Fax: 407-320-8083

E-mail: search@florasearch.com

www.florasearch.com

SOFTWARE

TAKE YOUR OFFICE WITH YOU
CLIP2Go



GPS Tracking + Bilingual Directions + Start/Stop Times for each Job

* Requires CLIPr, a Windows Mobile device, Garmin mapping software, Microsoft MapPoint and GPS receiver.

To Learn more call

800-635-8485

www.clip.com

Keep your
business
growing.

Advertise in Landscape
Management. Contact
Kelli Velasquez today:

216-706-3767

kvelasquez@questex.com

RESOURCES

AD INDEX

Adkad Technologies.....	p60
Agrium Advanced Technologies.....	p33
Ameristar Fence.....	p20
The Andersons.....	cv3
Arctic Snow & Ice.....	p46
Ariens Company.....	p53
BASF Corp.....	p11, 31
Ball Horticultural.....	p56
Blizzard.....	p43
Bobcat Company.....	p19
Boss Snowplows.....	p49
Corona Clipper.....	p18, 32
Daimler Vans USA, LLC.....	p14-15
Dodge Chrysler.....	cv2-1
Dow AgroSciences.....	p37
Drafix Software.....	p24
DuPont.....	p55
Earthway Products.....	p58
FMC Professional Solutions.....	p17, 35
Hiniker Co.....	p45
Horizon.....	p22
Hortica.....	p25
John Deere Commercial.....	p5
John Deere Construction.....	cv4
L T Rich Products.....	p59
Meyer Products.....	p47
Mistaway Systems.....	p16
Modeco Systems.....	61
Mow More Landscape Supplies.....	Outsert (reg)
NuFarm.....	p12-13, 26, 27
PBI/Gordon.....	p7, 21, 59
Progressive Insurance.....	p10
Pro-Tech Mfg.....	p50
Syngenta.....	p23A
Trynex International.....	p48
U S Lawns.....	p3
Valent USA.....	p29A
Vista Professional.....	p58
Western Products.....	p40

Indices are provided as an additional service. The publisher does not assume any liability for errors or omissions.

EDIT INDEX

3PG Consulting.....	28
Agrium Advanced Technology.....	20
Ball Horticultural.....	57
Benary.....	59
Cleary Brothers Landscape.....	52
Colorado Assoc. of Lawn Care Pros.....	18
Dow AgroSciences.....	36
Elysian Design Group.....	42
Garden Debut.....	59
Greener By Design.....	10
HighGrove Partners.....	.61
Lifescape Associates.....	20
Mirrorscapes.....	12
PanAmerican Seed.....	57
PLANET.....	4, 8, 60
SnowEx.....	39
Swingle Lawn, Tree & Landscape Care.....	34
Syngenta Flowers.....	57
Terra Nova Nurseries.....	59
The Davey Tree Expert Co.....	18
ValleyCrest Landscape Cos.....	60
Wilson-Oyler Group.....	38
YardApes.....	4, 10

AFFILIATE ASSOCIATIONS



LANDSCAPE MANAGEMENT (ISSN 0894-1254) is published monthly (12 issues per year) by Questex Media Group LLC, 306 W Michigan St, Suite 200, Duluth, MN 55802. **Subscription rates:** one year, \$54, two years \$76 in the United States & Possessions; \$87 for one year, \$127 for two years in Canada and Mexico; all other countries \$165 for one year, \$246 for two years. For airmail delivery, include an additional \$75 per order annually. Single copies (pre-paid only): \$8 in the United States; \$10 in Canada and Mexico; \$15 all other countries. Back issues, if available: \$16 in the U.S.; \$20 in Canada and Mexico; \$30 all other countries. Add \$6.50 per order for shipping and handling. **Periodicals postage paid** at Duluth, MN 55808 and additional mailing offices. **POSTMASTER:** Please send address changes to *Landscape Management*, P.O. Box 1288, Skokie, IL 60076-8288. Canadian G.S.T. number: 840 033 278 RT0001. Publications Mail Agreement Number 40017597. Printed in the U.S.A.



Copyright 2010 Questex Media Group LLC. All rights reserved. No part of this publication may be reproduced or transmitted in any form or by any means, electronic or mechanical, including by photocopy, recording, or information storage and retrieval system, without permission in writing from the publisher. Authorization to photocopy items for internal or personal use, or the internal or personal use of specific clients, is granted by Questex Media Group LLC for libraries and other users registered with the Copyright Clearance Center, 222 Rosewood Dr., Danvers, MA 01923 phone: 978-750-8400 fax 978-750-4470; call for copying beyond that permitted by Sections 107 or 108 of the U.S. Copyright Law. For those not registered with the CCC, send permission requests to questexpermissions@theygsgroup.com or phone 800-494-9051 ext. 100.

Landscape Management does not verify any claims or other information appearing in any of the advertisements contained in the publication, and cannot take any responsibility for any losses or other damages incurred by readers in reliance on such content. *Landscape Management* welcomes unsolicited articles, manuscripts, photographs, illustrations and other materials but cannot be held responsible for their safekeeping or return. Questex Media Group LLC provides certain customer contact data (such as customers' names, addresses, phone numbers and e-mail addresses) to third parties who wish to promote relevant products, services and other opportunities which may be of interest to you. If you do not want Questex Media Group LLC to make your contact information available to third parties for marketing purposes, simply call 866-344-1315; 847-763-9594 if outside the U.S. between the hours of 8:30 am and 5:00 pm CT and a customer service representative will assist you in removing your name from Questex Media Group LLC's lists.





A thousand awesome things

Maybe Neil Pasricha was having a bad day. As the story goes, he got tired of opening the daily paper reading about war, crime and natural disaster — in other words, bad news. So he started a little blog (1000awesomethings.com) to remind himself — and the rest of us — about the little things in life that make us so happy.

“1,000 Awesome Things” won a number of blog awards, and soon became so popular that Pasricha was approached by literary agents. Last month, he turned his blog into “The Book of Awesome,” published by Penguin.

Pasricha started his list in June 2008, and counts backward from 1,000 every weekday. He’s about halfway through the list.

Some of Pasricha’s awesome things are pretty obvious:

#995. Finding money you didn’t even know you lost.

#828. Remembering what movie that guy is from.

#575. When the guy with a full cart of groceries lets you go ahead because you’re only buying one thing.

Others are... let’s say a matter of personal preference:

#975. Airplane toilet flushes.

#929. Your colon.

But it doesn’t really matter if you agree with his idea of awesome. The point is to appreciate the little things that, while easy to overlook, enrich our lives beyond measure. Some of them are under our control (**#858.** The other side of the pillow.) and some we luck into (**#913.** Having a whole row by yourself on the plane.). Either way, if we can stop for a moment and appreciate that brief moment of joy, then it helps us accept the thousand horrible little things that it is human nature to dwell on.

In fact, when I’m really in the right frame of mind, I can even appreciate those events that might otherwise really tick me off — getting stuck at an intersection while the slow driver in front of me just squeaks through before the light turns red. Who knows, maybe if I’d made that light I would have been blindsided by a car coming the other direction. Maybe it’s just bad luck, but the more I dwell on the positive, the less stressed I am by the negative.

I’ve started my own list of awesome things: a baby’s laughter, watching my daughter play softball, the building excitement as my son finishes high school and prepares for college.

Let’s face it. Work is stressful. We’ve written many articles talking about work-life balance — the idea that you can’t spend all of your time on the business. You must focus on your personal life, too. While that’s true, we all know during the busy season, there are times when the family or even your own needs take a back seat to the company. All of our preaching isn’t going to change that. And if I’m being honest, there are times when I’m at the office more than I’m home.

It’s during those times when it’s most important to take that moment to appreciate the awesome little things that happen when you least expect them, like **#699.** A long hug when you really need it.

#566. Unforgettable friends.
#553. When a friend returns something they borrowed so long ago that you forgot you owned it. **#997. Locking people out of the car and pretending to drive away.**



PROPHECY™ FUNGICIDE

Disease Control With DG Pro Convenience

Fast Acting Dispersing Granules.

Prophecy fungicide delivered to your turf via fast acting DG Pro technology provides prevention of dollar spot, brown patch, anthracnose, rust and over a dozen other common turf diseases.

Because it is a DG (Dispersible Granule) Pro product. With light watering, Prophecy immediately begins to dissolve into the target areas, eliminating any chance of mower pickup, runoff or tracking. That means the easy to apply treatment provides a no-waste solution to your disease control program.

Find out more about why you should add Prophecy into your turf maintenance schedule. Contact your Andersons distributor today or visit www.andersonsturf.com



The Andersons



**DESIGNED TO MEET THE MOST DEMANDING SPECS.
YOURS.**

You said you needed a small “big” excavator. Consider it done. Weighing in at just over 18,400 pounds, the 85D still manages to pack plenty of your other big ideas into its reduced-tail-swing design. Versatility? It sports a standard blade, a swing boom for tight work, and three track options: continuous rubber belt, rubber crawler pads, or steel tracks. For big excavator technology (and reliability) in a compact package, see your dealer or call 800-503-3373. Productivity? Uptime? Low Daily Operating Costs? We’re On It.™



JOHN DEERE

JohnDeere.com/85D

VISIT US AT OUR WEBSITE... www.mowmore.com

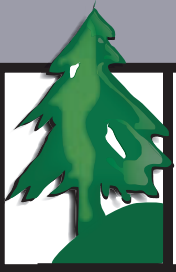

MOW MORE
LANDSCAPE SUPPLIES, INC.

2010



blades

trimmer

line



filters

and more

QUALITY, DEPENDABLE SERVICE



FREE SHIPPING!

on orders of \$250 or more

Excluding oil and grinders

\$25 MINIMUM ORDER



EASY ORDERING • 800-866-9667 • www.mowmore.com • 24 HOUR FAX 716-937-3155

Top Quality

Products made for the professional user. We do not offer lower quality products. We only sell best quality so that you have less down time and put more profits in your pockets.

Premium Parts

Only parts of the best quality are selected for our catalog. Premium service, premium parts without the premium price.

We ARE Your Warehouse

Running a business is challenging; let us simplify your supply chain and let you focus on your business. Thousands of lawn care products at great prices.

In a fast pace industry it is important for the focus to be on your company. We will not insult your intelligence MOW MORE will save you valuable time. We ARE the warehouse. Premium service and merchandise without the premium price.

Tom Ulbrich
President
Mow More Landscape Supplies

Free Direct Shipping

Free means Free. With every \$250 order we cover the shipping, some exclusions* apply. Easy ordering, free shipping right to your door.

Service

Friendly, professional representatives provide you the service with respect you deserve.

Call us Toll Free

1-800-866-9667
8:30am to 5:00pm E.S.T.

Visit our Website

www.mowmore.com

Order by Fax Anytime

716-937-3155

Email us at

sales@mowmore.com



**Premium Replacement Parts
When You Need Them So You
Can Mow More For LESS!**

Page 17

BULK BUY!



Edger Blade
Top Quality Blade
Mow More Catalog #EBU8

Replaces OEM #'s
840084 • 216062
4133-713-4101
720-237-001
613223

Fits Maruyama, Ryobi, Echo,
Green Machine, Shindaiwa
and Stihl.

Long lasting heat treated

Specs: 7-11/16" long
1" center hole
2" wide
.125" thick

Price Each	Price 10+	Price 50+	Price 200+
\$2.15	\$1.85	\$1.60	\$1.35

BULK BUY!



Kawasaki
Air Filter

Mow More Catalog #KA9506

Replaces
Kawasaki #11013-7002
• Fits FH-500V Engine 17 HP
• Waffle Panel Filter

Specs: 6 1/2" wide

Price Each	Price 10+
\$9.75	\$8.75
Price 30+	Foam Pre-Wrap
\$7.75	order #KA9506F
	\$2.15 Each 10+ \$1.60 Each

AIR FILTERS
Page 19



Kohler & Kawasaki
Air Filter

Mow More Catalog #KO9583

Replaces Kohler #25-083-01
• Fits Gravely 21537000 and Toro Z-Master 200 series.
• Midmount design ZTR Mowers with Kohler CommandPro Engines 23 and 25 HP
• 52", 62" and 72" cut decks.
• Also replaces Kawasaki # 11013-7020
• And Fleetgard AF 25551.

Bulk Buy Deal

Specs: 4" long
2 13/32" wide
x 10.5" height

Price Each	Price 10+
\$14.50	\$12.99

Inner Filter Available
order #KO9583F
\$14.25 Each 10+ \$13.50 Each

BULK BUY!



Oil Filter
Top Quality Filter

Mow More Catalog #KA71
Replaces Kawasaki OEM #'s
490652071 • 490652078
• 490652057 • Fits most
Kawasaki Engines
• Replaces John Deere
#AM107423 and #AM101054

• Onan # 122-0737
• Wheelhorse #NN10684
• Woods #72859
• Snapper #77355

Specs: 3/4"-16 thread
2 11/16" OD
2 7/8" height
25 micron

Price Each	Price 12+	Price 36+	OIL FILTERS
\$5.60	\$4.35	\$3.35	Page 24

BULK BUY!



Elvex
Ultra Lite Ear Muffs

Mow More Catalog #HB25

• 25DB NRR rated
• Extremely Lightweight
• Great Value!

Specs: 6.8 oz weight
25DB NRR rated
Adjustable Fit
Blue color

Price Each	Price 3+	Price 6+
\$9.50	\$8.60	\$7.50

SAFETY EQUIPMENT Page 29

Order ONLINE

www.mowmore.com

Call us Toll Free

1-800-866-9667

8:30am to 5:00pm E.S.T.

BULK BUY!



Specs: 2 step filter
1/4" & 5/16" nipple
60 micron

Fuel Filter
Economy
Mow More Catalog #FF1358E
Replaces OEM: Gravely 21410800
Onan 149-220601
Bobcat 38283/38666
Bunton PM244
Exmark 303197
Jacobsen 552265.
John Deere AM116304
Kohler 2505003
Large in-line filter

Price Each
\$1.70

Price 10+
\$1.45

Price 30+
\$1.30

FUEL FILTERS
Page 23

BULK BUY!



Specs: Top Quality

Spark Plug
NGK
Mow More Catalog #NGBPM8Y
Replaces NGK BPM8Y

Price Each
\$3.35

Price 10+
\$2.85

Price 100+
\$2.45

SPARK PLUGS
Page 18

BULK BUY!



Trimmer Line
Ultra Edge Round
Mow More Catalog #TL5095
Top Quality
Formulated for Commercial Use

Specs: .095 Size
Call for others

Price Each
\$39.99

Price 3+
\$37.99

Price 12+
\$33.99

TRIMMER LINE
Page 17



R.B.G. Grinder
Model BG121
Mow More Item #BG121
Perfect for the small pro shop.
Do it yourself and save money!
Specs: 1/2 HP reversible motor
8" Hardened Ruby wheel
Fast bevel adjustment
Steel work table

Grinds right or left handed blades.
Sharpen standard and mulching blades
(optional mulch plate adapter available)

Your Price
\$425.99
F.O.B NY

Mulching Plate Adapter
order #RBG1245
\$30.99 Each

Blade Grinders
Page 31

BULK BUY!



Safety Glasses
TTS Truly Terrestrial Spectacle
Mow More Catalog #SG15G and #SG15C
Popular Alien style safety glasses, close fit and excellent protective features. Economy and style.
Specify grey or clear lens when ordering.

Specs: Clear lens
Grey lens
1 size fits most

Price Each
\$3.95

Price 5+
\$3.35



MOW MORE
LANDSCAPE SUPPLIES, INC.



Call for your complete catalog with 1000's of parts inside!





Premium Replacement Parts
When You Need Them So You Can **Mow More For LESS!**

ALL BLADES ARE MADE IN THE USA FROM HIGH QUALITY STEEL AND ARE HEAT TREATED FOR OPTIMUM HARDNESS. WHEN THE REPUTATION, SAFETY AND PERFORMANCE OF YOUR EQUIPMENT IS AT STAKE, THERE IS NO BETTER BLADE THAN AN AUSTEMPERED (MADE IN THE USA) BLADE.



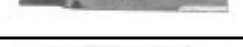



BOBCAT/RANSOMES

Mow More Catalog #	Replaces O.E.M. #	Length	Center Hole	Width	Thickness	Price Each	Price 12+	Quantity/Fits
BC16	 32061A 32061	16-1/4"	5/8"	2-1/2"	.240	10.15	9.25	Heavy Duty (2) blades for 32" cut. (3) blades for 48" cut.
BC16A	 112111-01	16-1/4"	5/8"	2-1/2"	.204	10.15	9.25	(2) blades for 32" cut. (3) blades for 48" cut. (formed blade)
BC16B	 32061A 32061	16-1/4"	5/8"	2-1/2"	.150	8.55	7.60	(2) blades for 32" cut. (3) blades for 48" cut.
BC18	 32022A	18"	5/8"	2-1/2"	.240	10.45	9.25	Heavy Duty (2) blades for 36" cut. (3) blades for 54" cut.
BC18A	 112111-02	18"	5/8"	2-1/2"	.204	10.15	9.25	(2) blades for 36" cut. (3) blades for 54" cut. (formed blade)
BC18C	 32022A	18"	5/8"	2-1/2"	.150	9.00	8.20	(2) blades for 36" cut. (3) blades for 54" cut.
BC21	 72039B	21"	3/8"	2-1/2"	.150	11.25	10.45	21" Push Mower.
BC21A	 42180B	21"	5/8"	2-1/2"	.240	11.25	10.45	Heavy Duty (3) blades for 61" cut.
BC21B	 112111-03	21"	5/8"	2-1/2"	.240	11.75	10.95	Heavy Duty (3) blades for 61" cut. (formed blade)
BC21C	 112243-03	21"	5/8"	2-1/2"	.240	11.75	10.95	Heavy Duty (3) blades for 60" cut.
BC25	 42139B 112111-04	25"	5/8"	2-1/2"	.240	13.50	13.10	Heavy Duty (3) blades for 74" cut.

BUNTON

BU16	 PL4055	16"	5/8"	2-1/2"	.204	8.55	7.90	(3) blades for 48" cut. (Standard Lift)
BU16B	 PL4855	16-1/2"	5/8"	2-1/2"	.204	8.55	7.90	Low Lift blade. (3) blades for 48" cut. Gear and Hydro drive midsize V-deck models.
BU16C	 PL4205	16-1/2"	5/8"	2-1/2"	.204	8.55	7.90	High Lift blade. (3) blades for 48" cut. Gear and Hydro drive midsize V-deck models.
BU18	 P2005	18"	5/8"	2-1/2"	.204	8.55	7.60	(3) blades for 52" cut. (Standard Lift)
BU18HL	 PL4206	18"	5/8"	2-1/2"	.204	8.55	7.60	(2) blades for 36" cut. (3) blades for 52" cut. (High Lift)
BU21	 PC005	21"	5/8"	2-1/2"	.204	10.15	9.25	(3) blades for 61" cut.









CUB CADET

CC15	 7423002 759-8312 7593812 59704-C1	15-1/8"	3/4"	2-1/2"	.204	8.55	7.60	(3) blades for 44" cut.
CC11805	 01008616	15.94"	3/4"	3"	.204	9.60	9.10	Fits Z Force Turn Rider. High Lift blade. (3) blades for 44" cut.
CC16	 489-393-R1 490-475-R1 759-3847	16"	3/4"	2-1/2"	.204	10.70	9.90	Takes (2) #CC16 and (1) #CC17A for 48" cut.
CC10636	 759-3939	16"	3/4"	2-1/2"	.204	9.25	8.75	(3) blades for 44" cut. Used on mowers from 2002 to present.
CC16A	 742-3019 742-3025 759-3825	16-1/2"	3/4"	2-1/2"	.204	10.15	9.60	(3) blades for 48" cut Garden Tractor model 2000 and Pro mid-size Walk Behind.
CC0361	 01005336	17"	3/4"	3"	.204	9.25	8.55	(3) blades for 48" cut. High Lift blade.
CC17	 742-3003 759-3813 59705-C1	17-3/16"	3/4"	2-1/2"	.204	10.95	9.90	(3) blades for 50" cut.







REPLACEMENT BLADES

REPLACEMENT BLADES

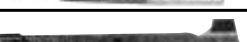

CUB CADET *continued*

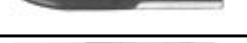
Mow More Catalog #	Replaces O.E.M. #	Length	Center Hole	Width	Thickness	Price Each	Price 12+	Quantity/Fits
CC11250 	01010168	17-29/32"	3/4"	2-1/2"	.204	10.95	10.15	High lift blade. (3) blades for 50" cut. Fits tank commercial.
CC11479 	742-04068 942-04068	17.90"	3/4"	2-3/8"	.160	10.15	9.00	(3) blades for 50" cut. Fits 1000 series hydrostatic lawn tractors. Model LT1024.
CC11480 	742-04053A 942-04053A	17.90"	Modified Star	2-3/8"	.160	10.15	9.00	(3) blades for 50" cut. Fits RZT series tractors. Model RZT50.
CC18 	742-3013 759-3820	18-1/2"	3/4"	3"	.204	12.10	10.95	(3) blades for 54" cut Garden Tractor and Pro mid-size Walk Behind.
CC0362 	01005337	19"	3/4"	3"	.204	11.75	10.70	(3) blades for 54" cut. High Lift blade.
CC10383 	1004719	20-1/2"	3/4"	3"	.204	12.40	11.25	(3) blades for 60" cut. Fits Cub Cadet and MTD Pro ZTR's with stamped steel decks.
CC0363 	01005338	21"	3/4"	3"	.204	11.75	10.95	(3) blades for 60" cut. High Lift blade.
CC11475 	759-3830 742-3033	21-1/4"	3/4"	2-3/4"	.204	10.99	10.25	3 in 1 blade. Fits deck series 1500 & 1517. (2) blades for 42" cut.





DIXIE CHOPPER

DC14 	30227-42	14-1/2"	5/8"	2-1/2"	.203	9.00	8.55	(3) blades for 42" cut.
DC17 	30227-50	17"	5/8"	2"	.204	9.60	8.75	(3) blades for 50" cut.
DC17HL 	30227H 30227-50H	17"	5/8"	2-1/2"	.204	9.00	8.20	(3) blades for 50" cut. ZTR
DC6442 	30227N 30227H	17"	5/8"	3"	.240	12.40	11.25	(3) blades for 50" cut. Fits ZTR models. (High Lift)
DC6790 	30227-50V	17"	5/8"	2-1/2"	.240	10.70	9.90	(3) blades for 50" cut. High Lift for wet grass.
DC6441 	30227-60H	20-1/2"	5/8"	3"	.240	13.50	12.70	(3) blades for 60" cut. (High Lift)
DC20HL 	30227-60-V	20-1/2"	5/8"	2-1/2"	.240	11.50	10.95	(3) blades for 60" cut. High Lift for wet grass.
DC6404 	30227-72H	24"	5/8"	2-1/2"	.240	14.60	13.50	(3) blades for 72" cut.
DC6833 	30227-72N	24"	5/8"	3"	.240	14.90	13.80	(3) blades for 72" cut. Heavy Duty.

DIXON

DI15HL 	8688	14-1/2"	11/16"	2-1/2"	.187	7.30	6.75	For ZTR models 428 and 429 (3) blades for 42" cut. (High Lift)
DI6766 	9444	17"	11/16"	2-1/2"	.187	8.75	7.90	(3) blades for 50" cut. (High Lift)
DI17 	9229	17"	5/8"	2"	.204	7.60	6.75	(3) blades for 50" cut standard deck.

EXCEL/HUSTLER

EX0372 	781898	17-7/8"	5/8"	3"	.240	12.40	11.50	(3) blades for 52" cut. Fits models Hustler Z, Super Z and Short Cut.
EXL11557 	795526 783753	17-7/8"	5/8"	2-1/2"	.204	10.99	10.25	(3) blades for 52" cut. Fits Super Z. High lift.
EX0373 	782516	21"	5/8"	3"	.240	13.10	12.40	(3) blades for 60" cut. Fits models Hustler Z, Super Z and Short Cut.
HQ10720 	795252	21"	5/8"	2-1/2"	.204	11.25	10.70	(3) blades for 61" cut.
EXL11721 	798496	22-1/2"	5/8"	3"	.204	12.25	11.50	(3) blades for 66" cut.



















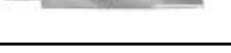

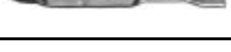

EXMARK

Mow More Catalog #	Replaces O.E.M. #	Length	Center Hole	Width	Thickness	Price Each	Price 12+	Quantity/Fits
EX6820 	653102 103-2519	15-1/4"	5/8"	2-1/2"	.204	10.15	9.25	(3) blades for 44" cut. Mulching blade.
EX0420 	103-1579	15-1/4"	5/8"	2-1/2"	.204	9.60	8.75	(3) blades for 44" cut. Solid Air Foil Hi-Lift.
EX11500 	103-6390	15-1/4"	15/16"	2-1/2"	.204	10.15	9.25	(3) blades for 44" cut. Mulching blade.
EX6821 	653101 103-2529	15-5/16"	5/8"	2-1/2"	.204	10.15	9.25	(3) blades for 44" cut. (High Lift)
EX11231 	103-6401	16-1/4"	15/16"	2-1/2"	.204	11.75	10.95	Notched air foil blade. (3) blades for 48" cut. High Lift blade.
EX11240 	103-6391	16-1/4"	15/16"	2-1/2"	.204	11.75	10.95	(3) blades for 48" cut. Mulching blade.
EX0419 	103-1577	16-1/4"	5/8"	2-1/2"	.204	10.15	9.25	(2) blades for 32" cut. (3) blades for 48" cut. Solid Air Foil High Lift.
EX9487 	1-323515	16-1/4"	5/8"	2-1/2"	.204	9.90	8.75	(3) blades for 48" cut, (2) blades for 32" cut. Fits Turf Tracer, HP Metro and Viking.
EX16 	103-6583 403059 103-2527	16-1/4"	5/8"	2-1/2"	.240	10.15	9.25	Heavy Duty (3) blades for 48" cut. (2) blades for 32" cut.
EX16A 	403026	16-1/4"	5/8"	2-1/2"	.150	8.55	7.60	(3) blades for 48" cut.
EX16B 	103-6581 103-2517 403086 & 403148	16-1/4"	5/8"	2-1/2"	.160	9.25	8.75	(3) blades for 48" cut. Mulching blade.
EX10718 	103-2507	16-1/4"	5/8"	2-1/2"	.204	9.90	9.25	(3) blades for 48" cut. Low Lift blade.
EX12002 	103-8251	16-1/4"	15/16"	3"	.204	11.25	10.70	High Lift blade. (3) blades for 46" cut.
EX18C 	303495	17-15/16"	5/8"	2-1/2"	.160	9.90	9.25	(2) blades for 36" cut. (3) blades for 52" cut. Mulching blade.
EX18E 	633484 103-2518 & 103-6582	17-29/32"	5/8"	2-1/2"	.204	10.15	9.25	(3) blades for 52" cut. Mulching blade. Fits 52" cut Lazer Z.
EX10071 	1-303527	18"	5/8"	2-1/2"	.204	10.70	9.60	(3) blades for 52" cut. High Lift blade. Fits Lazer Z.
EX18 	103-2528 303283 & 633482	18"	5/8"	2-1/2"	.240	10.45	9.25	Heavy Duty (2) blades for 36" cut. (3) blades for 52" cut
EX18A 	303146	18"	5/8"	2-1/2"	.150	9.00	8.20	(2) blades for 36" cut. (3) blades for 52" cut.
EX10719 	103-2508	18"	5/8"	2-1/2"	.204	10.15	9.25	(3) blades for 52" cut. Low Lift blade.
EX11241 	103-6392	18"	15/16"	2-1/2"	.204	12.40	11.75	(2) blades for 36" cut. (3) blades for 52" cut. Mulching blade.
EX11495 	103-6402	18"	15/16"	2-1/2"	.204	10.45	9.60	(2) blades for 36" cut. (3) blades for 52" cut. High Lift blade.
EX11778 	103-9607	19-1/2"	15/16"	3"	.204	11.75	10.70	(3) blades for 56" cut. Medium Lift blade.
EX12004 	103-9606	19-1/2"	15/16"	3"	.204	12.99	11.99	High lift blade. (3) blades for 66" cut.
EX11242 	103-6393	20-1/2"	15/16"	3"	.204	12.70	11.75	Fits Lazer model. (3) blades for 60" cut. Mulching blade.
EX11249 	103-6383	20-1/2"	15/16"	2-1/2"	.240	15.20	14.10	Air foil blade. (3) blades for 60" cut. High Lift blade.
EX11224 	103-6403	20-1/2"	15/16"	2-1/2"	.204	12.10	11.25	High lift blade. (3) blades for 60" cut. Notched Air Lift blade.
EX11139 	103-0301	20-1/2"	5/8"	3"	.204	13.50	12.40	(3) blades for 60" cut. Mulching blade.
DC20HL 	633483	20-1/2"	5/8"	2-1/2"	.240	11.50	10.95	(3) blades for 60" cut. (High Lift for wet grass) Fits Lazer Z or Turf Ranger.







REPLACEMENT BLADES

REPLACEMENT BLADES

EXMARK continued

Mow More Catalog #	Replaces O.E.M. #	Length	Center Hole	Width	Thickness	Price Each	Price 12+	Quantity/Fits
EX10667 	103-2530 105-7718	20-1/2"	5/8"	2-1/2"	.204	10.15	9.60	(3) blades for 60" cut. Notched High Lift blade.
EX20A 	603874	20-1/2"	1/2"	2-1/2"	.204	12.10	10.95	(3) blades for 60" deck. Mulching blade for Explorer, Lazer Z and Turf Tracer.
EX20HL 	603283	20-1/2"	1/2"	2-1/2"	.204	9.90	9.00	(3) blades for 60" deck. Standard high lift for models Explorer, Explorer II, Turf Ranger and Turf Tracer.
EX20B 	613112	20-1/2"	5/8"	2-1/2"	.204	10.95	10.15	(3) blades for 60" cut. Mulching blade. Fits 60" Lazer Z.
EX0249 	612111 103-2510	20-1/2"	5/8"	2-1/2"	.204	10.95	10.15	(3) blades for 60" deck. Low Lift Sand Blade.
EX12005 	103-8244	20-3/4"	15/16"	3"	.204	12.80	11.75	High Lift blade. (3) blades for a 60" cut.
EX11782 	103-8396	20-3/4"	15/16"	3"	.204	12.80	11.75	Medium Lift blade. (3) blades for a 60" cut.
EX11783 	103-8107	20-3/4"	15/16"	3"	.204	12.80	11.75	Mulching blade. (3) blades for a 60" cut.
EX12027 	103-9618	22-3/4"	15/16"	3"	.204	13.90	12.80	High Lift blade. (3) blades for a 66" cut.
EX11786 	103-9619	22-3/4"	15/16"	3"	.204	13.90	12.80	Medium Lift blade. (3) blades for a 66" cut.
EX6481 	643006 103-2531	24-13/32"	5/8"	3"	.204	12.40	11.75	(3) blades for 72" cut. Fits Lazer Z.
EX9882 	1-643097 103-2521	24-1/2"	5/8"	3"	.204	14.60	13.50	(3) blades for 72" cut. Mulching blade. Fits Lazer Z units.
EX0421 	103-1581	24-1/2"	5/8"	3"	.204	14.60	13.50	(3) blades for 72" cut. Solid Air Foil Hi-Lift.
EX11244 	103-6394	24-1/2"	15/16"	3"	.204	14.10	13.10	Fits 72" Lazer model. (3) blades for 72" cut. Mulching blade.
EX11229 	103-6404	24-1/2"	15/16"	3"	.204	14.60	13.50	Fits 72" Lazer model. (3) blades for 72" cut. Air Foil Lift blade.
FERRIS								
FE9967 	1520843	16-1/4"	5/8"	2"	.240	12.40	11.50	(3) blades for 48" cut. Low lift blade sharpened 4 sides.
FE18 	1521227	18"	5/8"	2-1/2"	.204	9.25	8.55	(2) blades for 36" cut. (3) blades for 52" cut.
FE21 	1520842	21"	5/8"	2-1/2"	.240	12.40	10.95	(3) blades for 61" cut. Fits mid-mount ZTR.
SC24 	22476	24-1/2"	5/8"	2-1/2"	.204	10.95	10.25	(3) blades for 72" cut.
GRASSHOPPER (WOODS)								
GH15A 	320233	15"	1/2"	2-1/2"	.240	10.15	9.60	Contour blade - fits 48" deck models 9548, 9548S, 9348, 9348S. 48" cut takes (1) GH15A and (2) GH18A.
GH15HL 	320232	15"	1/2"	2"	.204	9.00	8.55	(3) blades for 44" cut (high lift). Also, 48" cut takes (1) GH15HL and (2) GH18HL blades.
GH18 	320236	18"	1/2"	2"	.204	8.55	7.90	(3) blades for 52" cut (standard lift). Also takes (2) GH18 and (1) GH15 for 48" cut.
GH18A 	320238	18"	1/2"	2-1/2"	.240	10.95	10.15	Contour blade - fits 48" deck models 9548, 9548S, 9348, 9348S. 48" cut takes (2) GH18A and (1) GH15A.
GH18HL 	320237 320239	18"	1/2"	2"	.204	8.75	8.20	(3) blades for 52" cut (high lift). Also 48" cut takes (2) GH18HL and (1) GH15HL blades.



GRASSHOPPER (WOODS) continued

Mow More Catalog #	Replaces O.E.M. #	Length	Center Hole	Width	Thickness	Price Each	Price 12+	Quantity/Fits
GH21 	320242	21"	1/2"	2"	.204	10.70	9.90	(3) blades for 61" cut (standard lift).
GH21A 	320242	21"	1/2"	2-1/2"	.240	10.70	9.90	Heavy Duty (3) blades for 61" cut (regular lift).
GH21HL 	320243 320245	21"	1/2"	2"	.204	10.15	9.60	(3) blades for 61" cut (high lift).
GH21HLA 	320243 320245	21"	1/2"	2-1/2"	.240	10.45	9.90	Heavy Duty (3) blades for 61" cut (high lift).
GH6401 	320242	21"	1/2"	2-1/2"	.240	10.25	10.15	(3) blades for 61" cut (medium lift).
GH6402 	320250	25"	1/2"	2-1/2"	.240	13.10	12.40	(3) blades for 72" cut (low lift).
GH6403 	320251 320253	25"	1/2"	2-1/2"	.240	13.10	12.40	(3) blades for 72" cut (high lift).

GRAVELY

EX16 	04919100	16-1/4"	5/8"	2-1/2"	.240	10.15	9.25	Heavy Duty (3) blades for 48" cut. (2) blades for 32" cut.
GR17 	11234 88616 8861651 08899300	17"	5/8"	2"	.204	7.30	6.75	(3) blades for 50" cut.
GR17A 	38947 206562	17"	5/8"	2"	.240	10.70	10.15	(3) blades for 50" cut sharpened 4 sides. Low Lift blade.
GR17B 	046998 87792 8779251 08899600	17"	5/8"	2-1/2"	.240	9.25	8.75	(3) blades for 50" cut ZTR. (high lift)
EX10071 	4916400	18"	5/8"	2-1/2"	.204	10.70	9.60	(3) blades for 52" cut.
GR18 	42124 88166 08899400	17-11/16"	5/8"	2"	.240	9.60	9.00	(2) blades for 36" cut (high lift).
GR20 	25124 89046 8904651 08899000	20-1/2"	5/8"	2"	.240	9.90	8.75	(2) blades for 40" cut. (3) blades for 60" cut.
GR20B 	52929 08899100	20-1/2"	5/8"	2-1/2"	.240	12.40	11.50	(3) blades for 60" cut. Fits ProMaster 300 and Pro 40. Mulching blade.
GR20D 	89796 046999 8979651	20-1/2"	5/8"	2-1/2"	.240	10.45	9.60	(3) blades for 60" cut.
GR20E 	48864 8781851	20-1/2"	5/8"	2-1/2"	.240	11.25	10.45	(3) blades for 60" cut. Mulching blade. Fits 60" mower with fabricated deck.
GR24 	047685 89838 8983851 08898800	24-1/2"	5/8"	2-1/2"	.240	12.10	11.25	(3) blades for 72" cut.

GREAT DANE





GR3403 	D18086	16-1/2"	5/8"	2-1/2"	.204	8.75	8.20	(3) blades for 48" cut.
GR3404 	D18037	18"	5/8"	2-1/2"	.204	9.00	8.20	(3) blades for 52" cut.
GR3434 	C39949	21"	5/8"	2-1/2"	.204	9.60	9.00	(3) blades for 61" cut.

ALL BLADES ARE MADE IN THE USA FROM HIGH QUALITY STEEL AND ARE HEAT TREATED FOR OPTIMUM HARDNESS. WHEN THE REPUTATION, SAFETY AND PERFORMANCE OF YOUR EQUIPMENT IS AT STAKE, THERE IS NO BETTER BLADE THAN AN AUSTEMPERED (MADE IN THE USA) BLADE.



REPLACEMENT BLADES

REPLACEMENT BLADES

HONDA

Mow More Catalog #	Replaces O.E.M. #	Length	Center Hole	Width	Thickness	Price Each	Price 12+	Quantity/Fits
HO21	 72511-960-004 Code#2801595 72511-VA2-690	20-7/8"	.845	2-1/4"	.150	7.30	6.75	Fits: HR214, HRA214 and HRA216. (See below for more Honda Walk-behind blades)
HO6431	 72511-VE2-000 Code#4010609	20-7/8"	.830	2-1/4"	.095	7.90	6.70	Lower blade. Use with our HO6430 upper blade. Fits 21" Walk-behind.
HO6430	 72531-VE2-001 72531-ZE2-010 72531-VE2-020	21"	1-17/64"	2-5/8"	.095	9.00	8.55	Upper blade. Use with our HO6431 lower blade. Fits 21" Walk-behind.
HO325100	 72511-VK6-000 7869381	21-1/4"	.807	3-1/2"	.098	11.25	10.50	Lower blade. Fits HRC216 K2 HXA.
HO325104	 72531-VK6-010 7869555	20-7/8"	1.25	2-5/8"	.118	10.99	10.25	Upper blade. Code 8504896. Fits HRC216 K2 HXA.





HUSQVARNA/YAZOO/KEES

HQ7010	 539-1032-74	14-7/8"	5/8"	2-1/2"	.204	10.45	9.90	(3) blades for 42" Commercial Mowers.
HQ6500	 539-100-340	16-1/4"	5/8"	2-1/2"	.204	10.70	10.15	(3) blades for 48" cut. Fits Husqvarna, Yazoo, Kees Commercial Mowers
HQ10720	 539-101-733	21"	5/8"	2-1/2"	.204	11.25	10.70	(3) blades for 61" cut.





JOHN DEERE

JD46	 AM31100 M41967	16"	11/16"	2"	.187	8.55	7.90	(3) blades for 46" cut. Model 300 Series.
JD16A	 M113517	16-5/8"	13/16"	2-1/2"	.204	9.60	9.00	(3) blades for 48" cut. Fits model F710. Mulching blade.
JD16B	 M115495	16-5/8"	13/16"	2-1/2"	.204	9.90	9.00	(3) blades for 48" cut.
JD0291	 M145476	17"	.800	2-1/2"	.204	9.00	8.55	(3) blades for 48" cut. Fits 48C Decks, since 1999.
JD0284	 M136194	17"	.904	2-1/2"	.240	11.50	10.95	(3) blades for 48" cut. Fits 7-Iron Decks.
JD10634	 GX20250	17"	.675	2-1/2"	.150	8.55	7.90	Fits L120 & L 130 series riders. (3) blades for 48" cut.
JD50	 AM39966 M86209	17-3/16"	11/16"	2-1/2"	.204	10.70	10.15	(3) blades for 50" cut.
JD18A	 M113518	18-5/8"	13/16"	2-1/2"	.204	9.60	8.55	(3) blades for 54" cut. Fits model F-725. Mulching blade.
JD18B	 M115496	18-5/8"	13/16"	2-1/2"	.204	9.60	8.75	(3) blades for 54" cut.
JD6738	 M122455	18-11/16"	1"x1-1/8"	2-1/2"	.204	10.70	9.90	Fits midsize commercial mowers models GS-25-36. (2) blades for 36" cut.
JD6480	 M136195	19"	7/8"	2-1/2"	.240	9.90	9.00	(3) blades for 54" cut. Fits the 7-Iron Deck.
JD0292	 M143520	19"	.800	2-3/4"	.204	11.25	10.45	(3) blades for 54" cut. Fits 54C Decks.
JD38A	 M82408 AM100946	19-1/2"	11/16"	2-1/2"	.204	10.95	10.15	(2) blades for 38" cut. For Riders.
JD38B	 M83459 AM100991	19-1/2"	11/16"	3"	.204	12.40	11.75	(2) blades for 38" cut. Fits models SX-38. (high lift)
JD20	 M87622 AM100538 M141785	20-1/2"	29/32"	2-1/2"	.313	14.90	14.10	(3) blades for 60" cut.
JD6479	 M128485	21"	7/8"	2-1/2"	.313	16.30	15.45	(3) blades for 60" cut. Fits the 7-Iron Deck.
JD330501	 TCU15881	21"	29/32"	3"	.250	16.99	15.99	(3) blades for 60" cut. Hi-lift blade for models 737, 757, 777, 797 and 997.

JOHN DEERE continued

Mow More Catalog #	Replaces O.E.M. #	Length	Center Hole	Width	Thickness	Price Each	Price 12+	Quantity/Fits
JD10635 	GX20249	21"	.675	2-1/2"	.150	8.55	7.90	Fits L100 & L110 series riders. (2) blades for 42" cut. Also fits Sabre and Scott mowers.
JD330587 	M131958	21"	29/32"	2-1/2"	.250	18.00	16.85	(3) blades for 60" cut. Fits models Z-Trak, M655, M653, F680 and 4000 series.
JD12380 	M154061	21"	7pt. star	2-3/4"	.204	13.50	12.75	Heavy duty blade. Fits 42" riders. Models 102, 115, 125 & 135. (2) blades for 42" cut.
JD25 	AM102401 M83363	24-15/16"	29/32"	2-1/2"	.313	17.45	16.30	(3) blades for 72" cut 9/16" lift.
JD25A 	M80783 AM38314 AM102402 & M141786	24-15/16"	29/32"	2-1/2"	.313	18.00	16.85	(3) blades for 72" cut. 1" lift.
JD12643 	TCU15882	25"	.900	3"	.250	15.99	14.99	High lift blade. (3) for 72" cut on 777, 797, 997, 1400 & 1500 series front mowers.





KUBOTA

KU16A 	76500-34330	16-5/8"	3/4"	2"	.204	9.90	9.00	(3) blades for 48" cut. Fits models RC62, 72 and 82. Decks: RC48-62A/F, RC48G and RC48-62H.
KU19 	76529-34330	18-11/16"	1-1/8"	2-1/2"	.240	10.45	9.60	(3) blades for 54" cut riders. Fits G1800, 1900 and 2000 models.
KU20B 	76539-34330 70000-00602	20-1/2"	1-1/8"	2-1/2"	.240	9.90	9.00	(3) blades for 60" cut. Fits tractor models B2150, B1750, B7100HSD, B1550, FZ2100, FZ2400, G1900 and G2000 with deck models RC60-17B, 60B, 60F221 and 60G0.
KU25 	76550-34330	24-9/16"	15/16"	2-1/2"	.240	12.40	11.25	(3) blades for 72" cut. Fits tractor models L2850, L2550, F2100, F2100F and F2400 with deck models RC72-78, RC72-F25, RC72-F20 and RC72-F24.





LAWN BOY

LB21 	683682 608094 612543 89844 611240 682915	20-7/8"	5/8"	3"	.134	8.20	7.60	For 21" Tri Cut (Standard) Most popular blade.
--	---	---------	------	----	------	-------------	-------------	---

LESCO

LE16 	021871	16-1/2"	5/8"	2-1/2"	.204	8.75	8.20	(3) blades for 48" cut.
LE16HL 	050111 High Lift	16-1/2"	5/8"	3"	.204	9.60	9.00	(3) blades for 48" cut (high lift).
LE18 	050125	18"	5/8"	2-1/2"	.204	9.00	8.20	(2) blades for 36" cut. (3) blades for 52" cut.
LE18HL 	482467 050140 High Lift	18"	5/8"	3"	.204	10.45	9.90	(2) blades for 36" cut. (3) blades for 52" cut. (high lift)
LE21 	050170	21"	5/8"	2-1/2"	.204	9.60	9.00	(3) blades for 61" cut.



SCAG

SC16 	482461 48110 & 481706	16-1/2"	5/8"	2-1/2"	.204	8.75	8.20	(2) blades for 32" cut. (3) blades for 48" cut.
SC16HL 	48184 High Lift 481710	16-1/2"	5/8"	3"	.204	9.60	9.00	(2) blades for 32" cut. (3) blades for 48" cut. (high lift)
SC340874 	482877	16-1/2"	5/8"	2-1/2"	.203	10.75	9.95	Notched blade. (3) blades for 48" cut. Fits Tiger Cub & Freedom Z decks.
SC18 	482462 48108 & 481707	18"	5/8"	2-1/2"	.204	9.00	8.20	(2) blades for 36" cut. (3) blades for 52" cut.
SC18HL 	48185 High Lift 481711	18"	5/8"	3"	.204	10.45	9.90	(2) blades for 36" cut. (3) blades for 52" cut. (high lift)

REPLACEMENT BLADES

ALL BLADES ARE MADE IN THE USA FROM HIGH QUALITY STEEL AND ARE HEAT TREATED FOR OPTIMUM HARDNESS. WHEN THE REPUTATION, SAFETY AND PERFORMANCE OF YOUR EQUIPMENT IS AT STAKE, THERE IS NO BETTER BLADE THAN AN AUSTEMPERED (MADE IN THE USA) BLADE.

SCAG continued

Mow More Catalog #	Replaces O.E.M. #	Length	Center Hole	Width	Thickness	Price Each	Price 12+	Quantity/Fits
SC21 	481708 48111/482879	21"	5/8"	2-1/2"	.204	9.60	9.00	(3) blades for 61" cut.
SC21HL 	481712	21"	5/8"	3"	.204	11.75	10.45	High lift. (3) blades for 61" cut.
SC24 	48112 481709	24-1/2"	5/8"	2-1/2"	.204	10.95	10.25	(3) blades for 72" cut.

TORO/WHEELHORSE

T014 	117192 3-11620 106077 106636	13-7/8"	3/4"	2"	.187	7.30	6.75	For 42" cut side discharge. Set of 3 replaces OEM #3-11620
T015 	540010 54-0010-03	15-1/2"	5/8"	2-1/2"	.187	8.20	7.90	(3) blades for 44" cut. Deck #57358, Groundsmaster model 117 and 1144 Rider Tractor.
T015HL 	554940	15-1/2"	5/8"	2-1/2"	.187	9.60	8.55	Fits model 30144 44" midsize cutting mower. (high lift)
T015A 	927952	15-1/2"	5/8"	2-1/2"	.187	7.60	7.05	(3) blades for 44" cut.
T016A 	106637 3-10607 106078	16"	3/4"	2"	.187	7.60	7.05	For 48" cut side discharge. Wheel Horse set (3-10607)
T017 	84-4370 93-0107	16-7/8"	21/32"	2-1/4"	.125	9.60	9.00	Fits 37" deck. Take (1) T017 and (1) T021C deck model 30137. Left hand cut, short blade.
DC17HL 	113579	17"	5/8"	2-1/2"	.204	9.00	8.20	(3) blades for 50" cut. Toro ZTR Heavy Duty High lift blade.
EX18 	105-7781	18"	5/8"	2-1/2"	.240	10.45	9.25	Heavy Duty (2) blades for 36" cut. (3) blades for 52" cut
T018 	270990 44-5480 27-0990-03	18"	1/2"	2-1/2"	.187	8.55	7.90	(2) blades for 36" cut. (3) blades for 52" cut. Groundsmaster and Timecutter Zero Turn.
T018HLA 	562390	18"	1/2"	2-1/2"	.187	9.60	8.30	(2) blades for 36" cut. (3) blades for 52" cut. (high lift)
T020A 	69-6920	20"	5/8"	2-1/2"	.240	10.70	9.90	Fits Toro 580D mower. (11) blades for 16' deck Groundsmaster.
EX10667 	105-7718	20-1/2"	5/8"	2-1/2"	.204	10.15	9.60	(3) blades for 60" cut. Notched High Lift blade.
T010928 	93-4106-03 108-3762-03	20-27/32"	7/16"	2-1/4"	.150	8.30	7.90	Fits 21" Recycler Walkbehind.
T021A 	260880 421000 42-10000-03	21"	7/16"	2-5/8"	.125	9.90	9.00	Toro Rear Bagger and Grassmaster.

FREE SHIPPING!

ON ORDERS OF \$250.00 OR MORE

Excluding oil and blade grinders.



www.mowmore.com

REPLACEMENT BLADES

TORO continued

Mow More Catalog #	Replaces O.E.M. #	Length	Center Hole	Width	Thickness	Price Each	Price 12+	Quantity/Fits
T021B 	62-7700 62-7700-03	21-1/16"	7/16"	2-3/4"	.134	9.60	9.00	Vac-U-Deck. For 21" rear bagger model 26622.
T021C 	84-4380 93-0106	20-7/8"	21/32"	2-1/4"	.125	10.70	9.90	Fits 37" deck. Takes (1) T021C and (1) T017. Deck model 30137. Left hand cut, long blade.
T010929 	104-8697-03 108-9764-03	21-23/32"	7/16"	2-1/4"	.150	8.75	7.90	Fits 22" Recycler Walkbehind, Personal Pace models.
T021H 	44-6250	21-1/2"	1/2"	2-1/2"	.187	10.15	9.00	(3) blades for 62" cut. Fits Toro 62" cut Groundsmaster.
T021RA 	14-9419 75-9420 91-2256	20-15/16"	7/16"	2-9/16"	.134	9.60	9.00	Blade only. Fits Toro 21" Recycler without saddle. Saddle blade stiffener sold separately.
T06465 	80-0510-03	-	-	-	-	2.25	2.00	Blade stiffener. Used with our T021RA blade.
T011821 	106-2247-03	21.675"	5/8"	2-1/4"	.160	11.25	10.70	(2) blades for 42" cut. Fits model Time Cutter Z - standard blade.
T09986 	94-1861	24-3/4"	1/2"	2-1/2"	.204	12.40	11.50	(3) blades for 72" cut. Fits 72" Groundsmaster.
T025 	295530 23-2410	25"	3/4"	2-1/2"	.240	14.10	13.20	(3) blades for 72" cut Groundsmaster. Left hand cut.
T06443 	98-3028	25"	7/8"	2-1/2"	.187	12.10	10.95	Fits 48" cut, model 320. Takes (1) T06443 and (1) T06444 for a 48" cut. Right hand blade.
T06444 	98-3029	25"	7/8"	2-1/2"	.187	12.10	10.95	Fits 48" cut, model 320. Takes (1) T06443 and (1) T06444 for a 48" cut. Left hand blade.
T025C 	85-6040	25-3/16"	1/2"	2-1/2"	.240	14.60	13.50	72" Recycler deck blade. Used on Groundsmaster models 322D, 322, 325D and 325.
T032M 	80-4430	31-3/8"	5/8"	2-1/2"	.187	11.50	10.95	Mulching blade for 32" rear engine riders.







WALKER

WA20L  LIMITED SUPPLY	5705-2	20"	5/8"	2-3/4"	.160	11.25	10.70	Fits 36" cut rear discharge. (Left hand)
WA20R 	5705-0	20"	5/8"	2-3/4"	.160	10.70	9.90	Uses (3) blades for 54" side discharge. (Right hand)
WA21M 	5705-10	21"	5/8"	2-3/4"	.160	11.50	10.70	(2) WA21M and (2) WA22M for 42" cut mulcher. Lower blade.
WA22M 	5705-11	21-15/16"	5/8"	2-3/4"	.160	11.50	10.70	(2) WA22M and (2) WA21M for 42" cut mulcher. Upper blade. Also (3) WA22M and (3) WA22R for 62" mulcher cut.
WA22L 	5705-4	22"	5/8"	2-3/4"	.160	10.95	10.45	(G.H.S.) Grass Handling System. Fits 42" cut rear discharge. (left hand)
WA22R 	5705-3	22"	5/8"	2-3/4"	.160	10.95	10.45	Fits 42" cut. Rear and side discharge (Right hand) also fits (3) blades for 62". Also (3) WA22M and (3) WA22R for 62" mulcher cut.
WA25L 	7705-2	25-1/16"	5/8"	2-3/4"	.160	11.75	11.25	(1) WA25L and (1) WA25R for 48" cut. Left hand blade.
WA25R 	7705-1	25-1/16"	5/8"	2-3/4"	.160	11.75	11.25	(1) WA25L and (1) WA25R for 48" cut. Right hand blade.
WA6793 	5706	-	-	-	-	8.75	7.90	Replaces Walker Blade Hub.
WA8801 	Bolt #F202	10-24x1				4.50		Package of 10, stainless steel.
WA8802 	Nut #F002	10-24				3.35		Package of 10, zinc plated, low carbon steel.



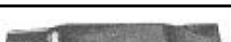

REPLACEMENT BLADES

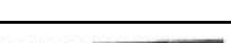
ALL BLADES ARE MADE IN THE USA FROM HIGH QUALITY STEEL AND ARE HEAT TREATED FOR OPTIMUM HARDNESS. WHEN THE REPUTATION, SAFETY AND PERFORMANCE OF YOUR EQUIPMENT IS AT STAKE, THERE IS NO BETTER BLADE THAN AN AUSTEMPERED (MADE IN THE USA) BLADE.

WOODS

Mow More Catalog #	Replaces O.E.M. #	Length	Center Hole	Width	Thickness	Price Each	Price 12+	Quantity/Fits
W06432	 31359	20-1/4"	5/8"	2"	.204	10.15	9.60	(3) blades for 60" cut. Fits models RM59, RM500, L59 and L35. (high lift blade) Left hand cut.
W06433	 34615	20-11/16"	5/8"	2-1/2"	.240	12.40	11.75	(3) blades for 60" cut. Fits new tunnel deck. Models RM360 and RM550. (high lift) Right hand cut.
W021	 23825 31359	20-5/32"	5/8"	2"	.204	9.60	8.75	(3) blades for 60" cut. For models RM-59 and L-59. Left hand cut (cw)
W06467	 6950	20-3/16"	5/8"	2"	.204	9.60	8.75	(3) blades for 60" cut. Fits model 59C2. (medium lift)
W021B	 70134	21"	1/2"	2-1/2"	.240	10.70	9.90	Heavy Duty (3) blades for 61" cut. (regular lift)
W021BHL	 70142	21"	1/2"	2-1/2"	.240	10.45	9.90	Heavy Duty (3) blades for 61" cut. (high lift)
W024	 13404 31306	24-1/2"	1"	2-1/2"	.204	12.10	10.95	(3) blades for 72" cut. Fits models L306, RM306 and RM600. Left hand cut.
W06434	 15127	24-11/16"	5/8"	2-1/2"	.240	14.90	14.10	(3) blades for 72" cut. Fits new tunnel deck models RM372 and RM660. (high lift)



EDGER BLADES

Mow More Catalog #	Replaces O.E.M. #	Length	Center Hole	Width	Thickness	Price Each	Price 10+	Price 50+	Quantity/Fits
EBS10	 2059 HD-10	10"	1/2"	2"	.150	2.69	2.59	2.39	Used on many Commercial Edgers. Sharpened four sides. Fits Little Wonder, Tanaka, McLane #2059-HD-10.
EBGM	 237001 696015-52631	7-11/16"	1"	2"	.095	2.25	1.95	1.70	Replaces: Green Machine 237001. Fits Edger Tool #2851, Shindaiwa #LE-20 also Echo 696015-52631 model PE2400.
EBU8	 840084 216062 4133-713-4101 720-237-001 613223	7-11/16"	1"	2"	.125	2.15	1.85	1.60	Fits Maruyama, Ryobi, Echo, Green Machine, Shindaiwa and Stihl. Long lasting heat treated.
						200+ only 1.35 each			
EBS276	 237001	8" DIA	1"	-	.095	4.75	4.25	3.99	Replaces: Green Machine 237001. Fits Edger Tool #2851. Also fits Echo model PE2400 and Shindaiwa model LE-20.



COMMERCIAL MULCHING BLADES

- GREATER CUTTING SURFACES FOR INCREASED MULCHING
- CENTRIFUGAL AIR LIFT DESIGN FOR UNIFORM CLIPPING DISTRIBUTION

BOBCAT

Mow More Catalog #	Replaces O.E.M. #	Length	Center Hole	Width	Thickness	Price Each	Price 12+	Quantity/Fits
MB6296	 32061A	16-1/4"	5/8"	2-1/2"	.204	10.70	10.15	Commercial Mulcher Blade. (2) blades for 32" cut. (3) blades for 48" cut.
MB6294	 32022A	18"	5/8"	2-1/2"	.204	10.95	10.45	Commercial Mulcher Blade. (2) blades for 36" cut. (3) blades for 54" cut.
MB6299	 42180B	21"	5/8"	2-1/2"	.204	13.10	11.75	Commercial Mulcher Blade. (3) blades for 61" cut.

BUNTON

MB6300	 PL4205 PL4855	16-1/2"	5/8"	2-1/2"	.204	10.70	10.15	Commercial Mulcher Blade. (3) blades for 48" cut.
MB6294	 PL4206	18"	5/8"	2-1/2"	.204	10.95	10.45	Commercial Mulcher Blade. (2) blades for 36" cut. (3) blades for 52" cut.
MB6299	 PC005	21"	5/8"	2-1/2"	.204	13.10	11.75	Commercial Mulcher Blade. (3) blades for 61" cut.



COMMERCIAL MULCHING BLADES

- GREATER CUTTING SURFACES FOR INCREASED MULCHING
- CENTRIFUGAL AIR LIFT DESIGN FOR UNIFORM CLIPPING DISTRIBUTION



CUB CADET

Mow More Catalog #	Replaces O.E.M. #	Length	Center Hole	Width	Thickness	Price Each	Price 12+	Quantity/Fits
MB12809 	742-04053A 942-04053A	17.9"	modified star	2-1/2"	.187	10.95	10.45	Commercial Mulcher Blade. (3) blades for 50" cut. Fits RZT series tractors.

DIXIE CHOPPER

MB6316 	30227-42	14-1/2"	5/8"	2-1/2"	.204	10.70	10.15	Commercial Mulcher Blade. (3) blades for 42" cut.
MB6298 	30227-50 30227-50V	17"	5/8"	2-1/2"	.204	10.95	10.45	Commercial Mulcher Blade. (3) blades for 50" cut.
MB6303 	30227-60 30227-60V	20-1/2"	5/8"	2-1/2"	.204	12.40	11.50	Commercial Mulcher Blade. (3) blades for 60" cut.

DIXON

MB6298 	9258 9265	17"	5/8"	2-1/2"	.204	10.95	10.45	Commercial Mulcher Blade. (3) blades for 50" cut.
MB6303 	9383	20-1/2"	5/8"	2-1/2"	.204	12.40	11.50	Commercial Mulcher Blade. (3) blades for 60" cut.



ENCORE

MB6294 	363291	18"	5/8"	2-1/2"	.204	10.95	10.45	Commercial Mulcher Blade. (2) blades for 36" cut. (3) blades for 58" cut.
--	--------	-----	------	--------	------	-------	-------	---



EXMARK

MB11243 	103-6395	15-1/4"	15/16"	2-1/2"	.204	11.75	10.95	(3) blades for 44" cut. Mulching blade.
EX9884 	653101	15-5/16"	5/8"	2-1/2"	.204	12.10	11.25	(3) blades for 44" cut.
MB11279 	103-6396	16-1/4"	15/16"	2-1/2"	.204	11.25	10.45	(3) blades for 48" cut. Mulching blade.
MB6296 	403059 403086 403026	16-1/4"	5/8"	2-1/2"	.204	10.70	10.15	Commercial Mulcher Blade. (3) blades for 48" cut.
MB6294 	303146 633482	18"	5/8"	2-1/2"	.204	10.95	10.45	Commercial Mulcher Blade. (2) blades for 36" cut.
MB6303 	613112	20-1/2"	5/8"	2-1/2"	.204	12.40	11.50	Commercial Mulcher Blade. (3) blades for 60" cut.
MB11469 	103-6398	20-1/2"	15/16"	2-1/2"	.204	13.50	12.70	Commercial Mulcher Blade. (3) blades for 60" cut.
MB11788 	103-9630	22-3/4"	15/16"	3"	.204	13.90	12.80	Commercial Mulcher Blade. (3) blades for 66" cut.

FERRIS

MB6296 	1520843	16-1/4"	5/8"	2-1/2"	.204	10.70	10.15	Commercial Mulcher Blade. (3) blades for 48" cut.
MB6299 	1520842	21"	5/8"	2-1/2"	.204	13.10	11.75	Commercial Mulcher Blade. (3) blades for 61" cut.

GRASSHOPPER

MB6415 	320231	15"	1/2"	2-1/2"	.204	11.50	10.95	Commercial Mulcher Blade. (3) blades for 44" cut.
MB6309 	320236 320237/320239	18"	1/2"	2-1/2"	.204	10.70	9.90	Commercial Mulcher Blade. (3) blades for 52" cut.
MB6311 	320242 320243 320245	21"	1/2"	2-1/2"	.204	14.10	13.10	Commercial Mulcher Blade. (3) blades for 61" cut.



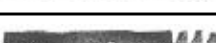





GRAVELY

MB6298 	087792 046998	17"	5/8"	2-1/2"	.204	10.95	10.45	Commercial Mulcher Blade. (3) blades for 50" cut.
MB6303 	089796 046999	20-1/2"	5/8"	2-1/2"	.204	12.40	11.50	Commercial Mulcher Blade. (3) blades for 60" cut.



COMMERCIAL MULCHING BLADES

**• GREATER CUTTING SURFACES FOR INCREASED MULCHING
• CENTRIFUGAL AIR LIFT DESIGN FOR UNIFORM CLIPPING DISTRIBUTION**

JOHN DEERE

Mow More Catalog #	Replaces O.E.M. #	Length	Center Hole	Width	Thickness	Price Each	Price 12+	Quantity/Fits
MB6300 	AM104489	16-1/2"	5/8"	2-1/2"	.204	10.70	10.15	Commercial Mulcher Blade. (3) blades for 48" cut.
MB6314 	M115495	16-5/8"	13/16"	2-1/2"	.204	11.25	10.45	Commercial Mulcher Blade. (3) blades for 48" cut.
MB12821 	M127673 M145476 & M127500	17"	.800	2-1/2"	.204	10.95	10.45	Commercial Mulcher Blade. (3) blades for 48" cut.
MB6294 	PT8721	18"	5/8"	2-1/2"	.204	10.95	10.45	Commercial Mulcher Blade.
MB6478 	M122455	18-11/16"	1x1-1/8"	2-1/2"	.204	12.40	11.50	(2) blades for 36" cut.
MB6315 	M115496	18-5/8"	13/16"	2-1/2"	.204	11.25	10.45	Commercial Mulcher Blade. (3) blades for 54" cut.
MB10072 	M136195	19"	7/8"	2-1/2"	.240	12.70	11.75	Commercial Mulcher Blades. (3) blades for 54" cut. Fits 7-Iron Deck.
MB10073 	M128485	21"	7/8"	2-1/2"	.240	13.80	13.10	Commercial Mulcher Blade. (3) blades for 60" cut. Fits 7-Iron Deck.



KEES

MB6296 	483011 76675 & 77378	16-1/4"	5/8"	2-1/2"	.204	10.70	10.15	Commercial Mulcher Blade. (2) blades for 32" cut.
MB6294 	363245 363055 77344 & 76450	18"	5/8"	2-1/2"	.204	10.95	10.45	Commercial Mulcher Blade. (2) blades for 36" cut. (3) blades for 54" cut.



KUBOTA

MB11558 	76539-34330 70000-00602	20-1/2"	1-1/8"	2-1/2"	.240	13.50	12.60	Commercial Mulcher Blade. (3) blades for 60" cut. Fits models B2150, B1750, B7100HSD, B1550, FZ2100, FZ2400, G1900 and G2000.
---	----------------------------	---------	--------	--------	------	-------	-------	---





LESCO

MB6300 	21871	16-1/2"	5/8"	2-1/2"	.204	10.70	10.15	Commercial Mulcher Blade. (2) blades for 32" cut. (3) blades for 48" cut.
MB6294 	50125 050140	18"	5/8"	2-1/2"	.204	10.95	10.45	Commercial Mulcher Blade. (2) blades for 36" cut. (3) blades for 52" cut.
MB6299 	050170	21"	5/8"	2-1/2"	.204	13.10	11.75	Commercial Mulcher Blade. (3) blades for 61" cut.

SCAG

MB6300 	A48184 A48110	16-1/2"	5/8"	2-1/2"	.204	10.70	10.15	Commercial Mulcher Blade. (2) blades for 32" cut. (3) blades for 48" cut.
MB6294 	48185 48108 481707	18"	5/8"	2-1/2"	.204	10.95	10.45	Commercial Mulcher Blade. (2) blades for 36" cut. (3) blades for 52" cut.
MB9229 	482235	18"	5/8"	2-1/2"	.204	14.10	12.40	Commercial Mulcher Blade.
MB6299 	A48111	21"	5/8"	2-1/2"	.204	13.10	11.75	Commercial Mulcher Blade. (3) blades for 61" cut.
MB9230 	482237/482693	21"	5/8"	2-1/2"	.204	15.70	14.60	Commercial Mulcher Blades.
MB9883 	48112	24-1/2"	5/8"	2-1/2"	.204	13.50	12.35	(3) blades for 72" cut.





TORO

MB9885 	54-0010	15-1/2"	5/8"	2-1/2"	.187	10.15	9.25	(3) blades for 44" cut.
MB6298 	113579	17"	5/8"	2-1/2"	.204	10.95	10.45	Commercial Mulcher Blade.
MB6410 	56-2390	18"	1/2"	2-1/2"	.187	11.25	10.45	Commercial Mulcher Blade. (3) blades for 52" cut.
MB6308 	75-9420	21"	7/16"	2-1/2"	.160	12.40	11.50	Commercial Mulcher Blade.
MB12649 	108-9764-03	21-23/32"	7/16"	2-1/4"	.150	14.25	13.50	Commercial Mulcher Blade.

COMMERCIAL MULCHING BLADES

TRIMMER LINE

WALKER

Mow More Catalog #	Replaces O.E.M. #	Length	Center Hole	Width	Thickness	Price Each	Price 12+	Quantity/Fits	
MB6414		5705-3	22"	5/8"	2-3/4"	.160	14.45	13.25	Commercial Mulcher Blade. Fits 42" cut rear discharge (right hand). Also fits (3) blades for 62" cut.
MB6413		5705-4	22"	5/8"	2-3/4"	.160	14.45	13.25	Commercial Mulcher Blade. Fits 42" cut rear discharge. (left hand)
MB6412		7705-1	25-1/16"	5/8"	2-3/4"	.160	15.25	14.10	Commercial Mulcher Blade. Fits 48" cut. Right hand blade.
MB6411		7705-2	25-1/16"	5/8"	2-3/4"	.160	15.25	14.10	Commercial Mulcher Blade. Fits 48" cut. Left hand blade.

PREMIUM CO-POLYMER ROUND

Premium Co-Polymer Trimmer Line

The Best \$ can buy!

Don't be misled by cheaper, low quality line offered by competitors.

- Special formula prevents "fraying and welding" of line
- Specially formulated for commercial use
- Top quality MN7 formulation
- Made in the U.S.A.
- Excellent wear/Long lasting
- The best line available for use by the landscape professional
- Top Quality Line



TL5095
12+
\$33.99

Mow More Catalog #	Line Size	Roll Size	Approx. Feet/Roll	Price	Price 3+
TL1080	.80	1#	400	8.99	8.45
TL1095	.095	1#	280	8.99	8.45
TL1105	.105	1#	230	8.99	8.45
TL1130	.130	1#	150	8.99	8.45
TL1155	.155	1#	99	8.99	8.45
TL3080	.080	3#	1200	26.99	24.70
TL3095	.095	3#	840	26.99	24.70
TL3105	.105	3#	690	26.99	24.70
TL3130	.130	3#	450	26.99	24.70
TL3155	.155	3#	300	26.99	24.70
TL5095	.095	5#	1400	39.99	37.99
TL5105	.105	5#	1150	41.50	38.99
TL5130	.130	5#	750	41.50	38.99
TL5155	.155	5#	500	41.50	38.99

PREMIUM DIAMOND EDGE - SQUARE CUT

Diamond Edge - Quad Cut Trimmer Line

The Best \$ can buy!

- Premium Co-Polymer
- Diamond Design for improved cutting performance
- Made in the U.S.A.
- Excellent wear & durability
- Diamond line
- Top Quality Line



Mow More Catalog #	Line Size	Roll Size	Approx. Feet/Roll	Price	Price 3+
TLD080	.080	1#	369	9.99	9.30
TLD095	.095	1#	263	9.99	9.30
TLD105	.105	1#	216	9.99	9.30
TLD130	.130	1#	141	9.99	9.30
TLD1155	.155	1#	90	9.99	9.30
TLD3080	.080	3#	1107	27.99	25.85
TLD3095	.095	3#	789	27.99	25.85
TLD3105	.105	3#	648	27.99	25.85
TLD3130	.130	3#	423	27.99	25.85
TLD3155	.155	3#	270	27.99	25.85
TLD5095	.095	5#	1315	42.70	39.99
TLD5105	.105	5#	1080	43.99	41.50
TLD5130	.130	5#	750	43.99	41.50

RINO-TUFF WITH INNER CORE





- New Technology
- Super Tough Inner Core
- Abrasion Resistant Shell
- Superior Toughness

Mow More Cat.#	Line Size	Roll Size	Approx. Ft./Roll	Price Each	Price Each 3+
TLR1080	.080	1#	400	10.40	9.60
TLR1095	.095	1#	280	10.40	9.60
TLR1105	.105	1#	230	10.40	9.60
TLR1130	.130	1#	150	10.40	9.60
TLR1155	.155	1#	99	10.40	9.60
TLR3080	.080	3#	1200	28.99	26.99
TLR3095	.095	3#	840	28.99	26.99
TLR3105	.105	3#	690	28.99	26.99
TLR3130	.130	3#	450	28.99	26.99
TLR3155	.155	3#	300	28.99	26.99
TLR5095	.095	5#	1400	43.75	41.50
TLR5105	.105	5#	1150	44.99	42.70
TLR5130	.130	5#	750	44.99	42.70

Spark Plugs

Mow More Catalog #	Autolite	Description	Replaces NGK	Replaces Champion	Replaces Autolite	Price Each	Price 10+	Price 100+
AU2974		2974 Autolite Plug	BPM7A	CJ7Y	2974	1.70	1.60	1.50
AU2976		2976 Autolite Plug	BPM6A	CJ8Y	2976	1.70	1.60	1.50
AU3924		3924 Autolite Plug	BCPR6ES	RC12YC	3924	2.40	2.20	2.10
AU458		458 Autolite Plug	B4LM	J19LM	458	1.70	1.60	1.50

Mow More Catalog #	Champion	Description	Replaces NGK	Replaces Champion	Replaces Autolite	Price Each	Price 10+	Price 100+
CHCJ14		CJ14 Champion Plug	BM4A	CJ14	258	2.00	1.90	1.75
CHCJ6		CJ6 Champion Plug	BM7A	CJ6	254	2.00	1.90	1.75
CHCJ7Y		CJ7Y Champion Plug	BPM7A	CJ7Y	2974	2.00	1.90	1.75
CHCJ8		CJ8 Champion Plug	BM6A	CJ8	255	2.00	1.90	1.75
CHCJ8Y		CJ8Y Champion Plug	BPM6A	CJ8Y	2976	2.00	1.90	1.75
CHJ19LM		J19LM Champion Plug	-----	J19LM	458	2.00	1.90	1.75
CHJ8C		J8C Champion Plug	B6S	J8C	295	2.00	1.90	1.75
CHRC12YC		RC12YC Champion Plug	BCPR6ES	RC12YC	3924	2.40	2.25	2.15
CHRCJ6Y		RCJ6Y Champion Plug	4626, BPMR7A	RCJ6Y	2974, 2984	2.50	2.40	2.25
CHRCJ8Y		RCJ8Y Champion Plug	BPMR6A	RCJ8Y	2985	2.50	2.40	2.25
CHRJ19LM		RJ19LM Champion Plug	B2	RJ19LM	308	2.40	2.25	2.15
CHRN11YC		RN11YC Champion Plug	BPR5ES	RN11YC	64	2.40	2.25	2.15
CHRN4C		RN4C Champion Plug	BR6ES	RN4C	403	2.85	2.70	2.60

Mow More Catalog #	NGK	Description	Replaces NGK	Replaces Champion	Replaces Autolite	Price Each	Price 10+	Price 100+
NGBCPR5ES		BCPR5ES NGK Plug	BCPR5ES	RC12YC	----	2.95	2.70	2.40
NGBCPR6ES		BCPR6ES NGK Plug	BCPR6ES	RC12YC	3924	2.85	2.55	2.25
NGBM6A		BM6A NGK Plug	BM6A	CJ8	255	2.30	2.15	2.05
NGBM7A		BM7A NGK Plug	BM7A	CJ4, CJ6	254	2.30	2.15	2.05
NGBMR6A		BMR6A NGK Plug	BMR6A	RCJ8	245	2.50	2.40	2.25
NGBP5ES		BP5ES NGK Plug	BP5ES	N11YC	54, 64	2.30	2.15	2.05
NGBP6ES		BP6ES NGK Plug	BP6ES	N9YC	4253	2.30	2.15	2.05
NGBPM6A		BPM6A NGK Plug	BPM6A	CJ8Y	2976	2.30	2.15	2.05
NGBPM7A		BPM7A NGK Plug	BPM7A	CJ7Y, CJ6Y	2974	2.30	2.15	2.05
NGBPM7Y		BPM7Y NGK Plug	BPM7Y for Echo Trimmers and Blowers			2.30	2.15	2.05
NGBPM8Y		BPM8Y NGK Plug	BPM8Y	----	----	3.35	2.85	2.45
NGBPMR4A		BPMR4A NGK Plug	BPMR4A	RCJ7Y	----	2.85	2.55	2.25
NGBPMR7A		BPMR7A NGK Plug	BPMR7A	RCJ7Y, RCJ6Y	2974	2.50	2.40	2.25
NGBPR2ES		BPR2ES NGK Plug	Used on Kawasaki 27HP watercooled FD750D			3.35	2.85	2.45
NGBPR4ES		BPR4ES NGK Plug	BPR4ES	RN14YC	4265	2.50	2.40	2.25
NGBPR5ES		BPR5ES NGK Plug	BPR5ES	RN11YC	64	2.50	2.40	2.25
NGBPR6ES		BPR6ES NGK Plug	BPR6ES	RN9YC	4264	2.50	2.40	2.25
NGCMR5H		CMR5H NGK Plug	CMR5H	Fits Stihl Trimmers		----	6.20	5.95
NGCMR6H		CMR6H NGK Plug	CMR6H	----	----	6.20	5.95	5.60
NGCMR-7A		CMR-7A NGK Plug	CMR-7A	----	----	6.20	5.55	5.10
NGCMR7H		CMR7H NGK Register Plug	CMR7H	----	----	6.20	5.95	5.45

BRIGGS & STRATTON AIR FILTERS

Don't See Your Filter?

Call 1-800-866-9667 with the O.E.M. Number

Briggs & Stratton Air Filter

ORDER #BS9168

Replaces O.E.M. 498596, 697029 & 690610. Fits 5.5 & 6.5 HP Intek engines. OD- 3-9/16", ID- 2-1/4", Height- 3"

Prewrap Available Order #BS9591F \$1.70ea 10+\$1.45ea.



Price Each \$6.75

Price 10+ \$6.20

Briggs & Stratton Air Filter

ORDER #BS77

Replaces O.E.M. #392642, 394018. 16 & 18 HP horizontal 402400, 421400, 422400 and V-Twin OHV Vanguard. OD- 7", ID- 5-5/8", Height 2-1/8"

Prewrap Available Order #BS77F \$1.55ea 10+\$1.40ea.



Price Each \$5.95

Price 10+ \$5.35

Briggs & Stratton Air Filter

ORDER #BS38

Replaces O.E.M. 399959, 491588. 3 & 5 HP Horz. Waffle Panel filter. Also fits 3.5 & 5 HP Quantum engines (top starter). Also fits JD #PT15853. OD- 5-1/4", ID- 4-1/2", Height 1"

Prewrap Available Order #BS38F \$1.60ea 10+\$1.40ea.



Price Each \$4.20

Price 10+ \$3.70

ECHO AIR FILTERS

Don't See Your Filter?

Call 1-800-866-9667 with the O.E.M. Number

Echo Air Filter

ORDER #EC102561

Replaces O.E.M. #13031051830. Fits models PAS2400, PB24LN, PAS2601, PE260, SRM2400, SRM2601, SRM2605, SRM3100, ES231, HCA2400, HCA261, and LST2400. Length or O.D. 3-1/16", Width or ID 3-7/64", Thickness or HT 5/16"

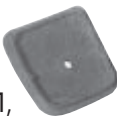

Price Each \$4.95

Price 10+ \$4.25

Echo Air Filter

ORDER #EC102565

Replaces Echo #13031054130. Fits models GT2000, GT1100, GT2400, SRM230 & SRM2100 Trimmers. ES2100, ES2400 Shredd & Vacs. HC1500, HC2000, HC2400, HC2410 Hedge Clippers. Power Pruners and 2400 Mantis Tillers



Price Each \$4.99

Price 10+ \$4.40

Echo Air Filter

ORDER #EC8735

Replaces #13030508360 & 13030508361. Fits backpack blower models PFB4600 and PB6000. Length or O.D.- 10-1/2", Width or I.D. 3", HT. 1-1/2"



Price Each \$6.75

Price 10+ \$6.20

Echo Air Filter

ORDER #EC10269

Replaces Echo #A226000031 & A226000032. Fits blowers PB-403, PB-413, PB-603, PB-611 and PB-650. 4-1/8" length, 2-3/4" width, 1-1/2" height

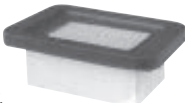

Price Each \$5.25

Price 10+ \$4.75

Echo Air Filter

ORDER #EC8585

Replaces O.E.M. #13031700760. Fits PB400E backpack blower. Length or O.D.- 7" (L.), Width or I.D. 1-3/4" (I.D.), Thickness or HT. 3-1/4 O.D.



Price Each \$10.15

Price 10+ \$9.55



Don't See Your Filter?

Call Us With the Filter O.E.M. #

1-800-866-9667

HONDA AIR FILTERS

Don't See Your Filter?

Call 1-800-866-9667 with the O.E.M. Number

Honda Air Filter

ORDER #HOS84

Replaces O.E.M. 17210ZE1821 & 7210ZE1505, 17210ZE1820, 17210ZE1822. Code 2893881, 5247408, and 144572. Honda 3.5, 5, 5.5 HP horz. Model GX110, GX120, GX140, GX160. Complete with foam wrap. OD- 4", ID- 2-7/8", Height- 2-5/8"

For Extra Prewraps Order #HOS84F \$1.70ea 10+\$1.45ea.



Price Each \$8.45

Price 10+ \$7.85

Honda Air Filter

ORDER #HO9953

Air filter replaces Honda 17211-ZL8-000, 17211-ZL8-023 and 17211-ZL8-003. code 5580402. fits units GC 135, GCV 135 & GC 160, GCV 160. ID - 4-1/2", OD - 5-1/4", Height - 3/4"



Price Each \$5.60

Price 10+ \$5.10

Honda Air Filter

ORDER #HO8906

Replaces O.E.M. #17211-ZE7-W03, Code 5357389. Pre-filter included. Fits 5.5 HP vertical shaft engine. O.D. - 6-3/4", Width or I.D. - 2-1/4", HT. - 2"



For Extra Prewraps Order #HO8906F \$3.10ea 10+\$2.85ea.

Price Each \$11.80

Price 10+ \$11.25

Honda Air Filter

ORDER #HO013

Replaces O.E.M. 17210ZE7013. Code 2741627. Fits 4 & 5 HP vertical engines GVX120, GVX140 GVX160 Commercial mower models HR216 & HRA216, Complete with foam wrap. OD- 7-1/2", ID- 2-1/2", Height- 1-7/8".

For Extra Prewraps Order #HO013F \$2.25ea 10+\$2.00ea.



Price Each \$8.45

Price 10+ \$7.85

Honda Air Filter

ORDER #HO010

Replaces O.E.M. 17210-ZE3-010 & 17210-ZE3-505. Code 2893907. Fits 8 thru 13 HP models. GX240, GX270, GX340, GX390. Complete with foam wrap. OD- 4-3/8", ID- 3-1/16", Height 3-5/8"



For Extra Prewraps Order #HO010F \$2.85ea 10+\$2.55ea.

Price Each \$11.80

Price 10+ \$11.25

Honda Air Filter

ORDER #HOS18

Replaces O.E.M. 17210-ZE2-822, 17210-ZE2-505, 17210-ZE2-821 & 17210-ZE2-521. Code 2538429. Honda 8 & 9 HP horz. models GX240 & GX270. Complete with foam wrap OD- 4", ID- 3-1/2", Height- 3-1/8"



For Extra Prewraps Order #HOS18F \$1.70ea 10+\$1.45ea.

Price Each \$11.80

Price 10+ \$11.25

KOHLER AIR FILTERS

Don't See Your Filter?
Call 1-800-866-9667 with the O.E.M. Number

Kohler Air Filter ORDER #K09583
Canister Filter. Replaces Kohler O.E.M. # 25-083-01, 25-083-01-S, Kawasaki 11013-7020, Gravely 21537000, Briggs & Stratton 841497, Exmark 103-1327, Fleetguard AF25551 & Generac OE3557 Hustler 785261. Fits Toro Z-Master 200 series. Mid mount design ZTR mowers with Kohler Command Pro engines 23 and 25 HP 52", 62" and 72" cut decks. Length or O.D. 4", Width or I.D. 2-13/32" Thickness or HT. 10-1/2".
Inner filter Sold Separately.
Be sure to match OEM#--similar, but different than K08302
For Inner Filter Order #K09583F \$14.25ea 10+\$13.50ea.



Price Each \$14.50	Price 10+ \$12.99
-------------------------------------	------------------------------------

Kohler Air Filter ORDER #K08302
Replaces Kohler O.E.M. #25-083-02-S. Canister filter. Fits canister models CH25, CH26 and TH16. Also replaces Kawasaki 11013-7029, Briggs & Stratton 820263, John Deere M113621, Gravely 21512500, Toro 108-3811, Walker # 5090-1, Fleetguard AF25550 Nelson 870119N O.D.- 3-1/2", I.D. 1-3/4", Height 7-3/8"
Inner filter Sold Separately.
**Be sure to match OEM#--similar, but different than K09583*
For Inner Filter Order #K08302F \$14.70ea 10+\$13.65ea.



Price Each \$15.75	Price 10+ \$14.70
-------------------------------------	------------------------------------

Kohler Air Filter ORDER #K08235
Replaces O.E.M. 12-083-10 & 12-083-16. Fits CV11-15 large capacity engines. Length - 3-1/4", Width or I.D. - 4-1/2", Thickness or HT. - 3-9/32"



Price Each \$8.50	Price 10+ \$6.99
------------------------------------	-----------------------------------

For Prewraps Order #K08235F \$2.00ea 10+\$1.65ea.

Kohler Inner Filter ORDER #K09583F
Inner filter for our K09583 air filter. Replaces Kohler 25-083-04, Kawasaki 11013-7019, Briggs, 821136, Exmark 103-1326, Gravely 21536900, Fleetguard AF25552, Generac OE3656 and Donaldson P822858



Price Each \$14.25	Price 10+ \$13.50
-------------------------------------	------------------------------------

Kohler Inner Filter ORDER #K08302F
Inner filter for our K08302 air filter. Replaces Kohler O.E.M. #25-083-03-S Fits models CH22-66557 and TH16-52527. Also replaces Walker # 5090-3, John Deere M123378 & Fleetguard AF26143 O.D.- 1-3/4", I.D. 1-15/16", Height, 6-11/16"



Price Each \$14.70	Price 10+ \$13.65
-------------------------------------	------------------------------------

Kohler Air Filter ORDER #K088
Replaces O.E.M. 4508302. Fits Kohler 10, 12, 14, 18 & 20 HP Magnum (vert. shaft) engines & CV22. Also fits Onan #140-1216, Cub Cadet #61606C1/1759-3359, Gravely 34776/43644 John Deere #AM37201. Also fits Kohler 16 HP K341 engine. Length - 6" (O.D.), Width or I.D. - 4-3/4", Thickness or HT. - 3"
For Prewraps Order #K088F \$2.15ea 10+\$1.95ea.



Price Each \$5.99	Price 10+ \$5.45
Price 30+ \$4.50	

Kohler Air Filter ORDER #K08329
Replaces O.E.M. 2408303. Fits CH25 Command 25HP OHV engine. Also fits CV18, 20, 22, & 26. Length - 7", Width or I.D. - 5-1/2", Thickness or HT. - 3"
For Prewraps Order #K08329F \$2.15ea 10+\$1.90ea.



Price Each \$6.15	Price 10+ \$5.60
Price 30+ \$4.80	

Kohler Air Filter ORDER #K089
Replaces Kohler O.E.M. #4708303 & 4788303S1. Fits 18 HP K361, along with some newer applications. Also replaces John Deere #AM47494 & Woods 71803. Fits 10 thru 22 HP models K241, K301, K321, K361. Length or O.D.- 7", Width or I.D. 5-1/2", Thickness or HT. 2-1/2"
For Prewraps Order #K089F \$2.25ea 10+\$2.05ea.



Price Each \$4.99	Price 10+ \$4.50
------------------------------------	-----------------------------------

Kohler Air Filter ORDER #K0305
Replaces O.E.M. #1208309, 1208305. Fits 11, 12.5 and 14 HP vert. OHV Kohler Command engines. Triangular shaped filter. Also fits John Deere #AM121608 & M92359. Length or O.D.- 4-1/2" (O.D.), Width or I.D. 3-3/8" (I.D.), Thickness or HT. 2-13/16"
For Prewraps Order #K0305F \$1.50ea 10+\$1.35ea.



Price Each \$7.95	Price 10+ \$6.25
------------------------------------	-----------------------------------

KUBOTA AIR FILTERS

Don't See Your Filter?
Call 1-800-866-9667 with the O.E.M. Number

Kubota Air Filter ORDER #KU8279
Replaces O.E.M. #70000-11221, 15222-11221. Also replaces Cushman 832537, Jacobsen 502619, John Deere CH-15541, AM108243, Onan 1402842, Toro 33-1300, Woods 70649 & Yanmar 171022-12530. Fits models B5100, B5200, B6100, B6100DT, B6100HST, B7100, B7100DT, B7100HST, B8200HST, L225, L225DT, L235, L245, L245DT, L245H, L260H (21 & 24 HP), L275. Length or O.D.- 3-9/32", Width or I.D. 1-11/16", Thickness or HT. 7-1/4"
Price Each \$18.95 **Price 10+ \$17.95**

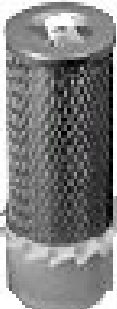

Kubota Air Filter ORDER #KU8328
Replaces 70000-11081. Also replaces John Deere CH12767, Toro 27-7110, Bobcat 48426, Dixie Chopper 90122. Fits models L275, 285, 295, 295DT, 305, 345, 345DT, 355SS, 2250, 2550, 2650, 2850, 2950, 3450, 3650, M4000, 4050, 4500, 4500C, 4500DT. Length or O.D.- 2-1/2", Width 4", Thickness or HT. 10-1/4"
Price Each \$22.45 **Price 10+ \$21.35**



LAWN BOY AIR FILTERS

Don't See Your Filter?
Call 1-800-866-9667 with the O.E.M. Number

Lawn Boy Air Filter ORDER #LB0183
Replaces O.E.M.# 955574. Fits late model 2-cycle mowers. Gold & Silver series. Length or O.D. 5-1/2", Width or I.D. 3", Thickness or HT. 1-1/4"
Price Each \$2.15 **Price 10+ \$1.60**



Lawn Boy Air Filter ORDER #LB80
Replaces O.E.M.# 609493. Fits Lawn Boy F Series 1978 and Up. Length or O.D. 4-1/2", Width or I.D. 2-1/2", Thickness or HT. 1"
Price Each \$1.10 **Price 10+ \$0.85**



RED MAX AIR FILTERS

Red Max Air Filter

ORDER #RE102602

Replaces O.E.M.# T401282310.

Fits EB7000 Back pack blowers.

Length or O.D.- 7-3/4", Width or I.D.5", Thickness or HT. 3/4"

For Prewraps Order

#RE102602F \$3.95ea 10+ \$3.35ea.



Price Each
\$10.15

Price 10+
\$9.00



MOW MORE
LANDSCAPE SUPPLIES, INC.

**Don't See
Your Filter?**

Call Us With the
Filter O.E.M. #

1-800-866-9667

SHINDAIWA AIR FILTERS

Shindaiwa Air Filter

ORDER #S102598

Replaces

Shindaiwa # 20018-81750

Fits model T-230 trimmers.

2-3/8" length, 2" width, 3/8" height

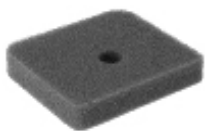

Price Each
\$2.15

Price 10+
\$1.90

Shindaiwa Air Filter

ORDER #S100325

Replaces Shindaiwa #60023-98031

Heavy Duty Air Filter.

Fits models AHS231, T231/T231B, T231X, T231XB

2.252" length, 1.867" width, .504" height



NEW!

Price Each
\$4.75

Price 10+
\$4.25

Shindaiwa Air Filter

ORDER #S100343

Replaces Shindaiwa #68206-82400

Fits models EB630 Blower

2.347" length, 3.843" width, 1.75" height



NEW!

For Prefilters Order

#S100556 \$2.25ea 10+ \$1.99ea.

Price Each
\$10.99

Price 10+
\$10.25

STIHL AIR FILTERS

Stihl Air Filter

ORDER #ST10963

Replaces Stihl #42031410301. Fits B420 and BR420 Blowers.

Length 5-1/8", Width 3-1/2", Height 1-1/4".

Pre-filter now available

For Prefilters Order

#ST10963F \$4.80ea 10+ \$4.50ea.



Price Each
\$5.80

Price 10+
\$5.25

Stihl Air Filter

ORDER #ST100709

Replaces O.E.M.#41371242800.

Fits models FS75, FS80, FS85, HL75K, FC75 and BG75.

Length or O.D.- 2-3/8", Width or ID 2-3/8", Thickness or HT. 1/4".

For Prefilters Order

#ST100713 \$1.90ea 10+ \$1.60ea.



Price Each
\$3.70

Price 10+
\$3.10

Stihl Air Filter

ORDER #ST12081

Replaces Stihl #4282-141-0300(B).

Fits Backpack blower models BR500, 550, 600.

- Length 4-1/2"
- Width 2-1/2"
- Height 1-1/4"



Price Each
\$7.99

Price 10+
\$7.25

Stihl Air Filter

ORDER #ST8716

Replaces O.E.M.#41331241500

Code #135263300.

Fits trimmer models FS74, 76, FC72, HS72, 74, 76 & BG72.

Length or O.D. - 2-7/16", Width or I.D. - 2-7/16", Thickness or HT. - 1/4".

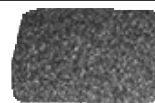

Price Each
\$1.70

Price 10+
\$1.30

TORO AIR FILTERS

Toro Air Filter

ORDER #TO91

Replaces O.E.M.#639380. Used on 2-cycle Suzuki equipped Toro models.

Length or O.D.- 6-9/16", Width or I.D. 3-3/8", Thickness or HT. 1-1/8"



Price Each
\$4.20

Price 10+
\$3.70

Toro Air Filter

ORDER #TO9550

Replaces Toro O.E.M.# 93-2195. Fits Toro "Z" series

mowers with Kawasaki 22HP engines. Also replaces

Kubota K1211-82320, Donaldson 822686 Walker 5090-01

Fits Kawasaki 12HP on John Deere Gator M113621 & Kohler

26HP on Walker. O.D. 3-1/2", I.D. 1-27/32", HT. 7-1/4"



Price Each
\$23.99

Price 10+
\$22.50

Toro Air Filter

ORDER #TO82

Replaces O.E.M.#810100.

Fits Toro/Suzuki 2-cycle engines.

Length or O.D.- 6-3/4"

Width or I.D. 3-5/8", Thickness or HT. 1-1/4"



Price Each
\$2.00

Price 10+
\$1.80



Premium Oil Filters

Replacement Oil Filters
for Most Major Brands

See Us Online
www.mowmore.com



Premium Mower Blades

Proudly Made in the U.S.A.
Blades for Most Major Brands

See Us Online
www.mowmore.com

FUEL FILTERS

Multi-Application Premium Fuel Filter
ORDER #FF1358
 Large in-line 2 step filter 1/4" & 5/16" nipple. Premium filter -see thru plastic housing. paper interior element. Replaces Toro #715960. 9-15 Microns. Used on many walk behind mowers, riders and small tractors.



Price Each \$2.10	Price 10+ \$1.80
------------------------------------	-----------------------------------

Multi-Application Economy Fuel Filter
ORDER #FF1358E
 Large in-line 2 step filter 1/4" & 5/16" nipple. 60 micron interior element. Replaces Gravely 21410800 • Onan 149-220601 • Bobcat 38283/38666 • Bunton PM244 • Exmark 303197 • Jacobsen 552265 • John Deere AM116304 • Kohler 2505003



Price Each \$1.70	Price 10+ \$1.45
------------------------------------	-----------------------------------

Universal Heavy Duty In-Line Fuel Filter
ORDER #FF12619
 Dual hose barbs that fit 1/4" & 5/16" ID fuel line. 80 Micron rating. 3-1/2" long. MADE IN THE USA. Features a high impact polymer-copolymer blend that will stand up to all standard and bio-based fuels including E85.



Price Each \$2.10	Price 10+ \$1.80
------------------------------------	-----------------------------------

Kawasaki and Gravely Fuel Filter
ORDER #FF054071
 Replaces Kawasaki 49019-7001 and Gravely 21538400. Fits models FC420V, FH381V, FH350V, FH451V, FH500V, FH531V, FH601V, FH641V, FH680V and FH721V. For 13 thru 20HP engines. Kawasaki original part.



Price Each \$7.85

Kohler Fuel Filter
ORDER #FF055121
 Original equipment in-line fuel filter. Kohler # 2505003-S, #2505008-S and #2505022-S. 51 Micron for 1/4" fuel line.



Price Each \$5.95

Walbro Trimmer Fuel Filter
ORDER #FF9025
 Replaces Walbro #125-528. Fits engines up to 80cc. For 3/16" ID fuel line. Felt filter.



Price Each \$2.60	Price 10+ \$2.35	Price 50+ \$2.15
------------------------------------	-----------------------------------	-----------------------------------

Walbro Trimmer Fuel Filter
ORDER #FF9024
 Replaces Walbro #125-527. Fits engines up to 33cc for 3/16" fuel line. Felt filter.



Price Each \$2.25	Price 10+ \$1.99	Price 50+ \$1.75
------------------------------------	-----------------------------------	-----------------------------------

Kawasaki Fuel Filter
ORDER #FF7001
 Aftermarket In-line fuel filter, replaces Kawasaki OEM# 49019-7001.

 For original Kawasaki fuel filter order #FF054071



Price Each \$4.99	Price 10+ \$4.25
------------------------------------	-----------------------------------

Kohler Fuel Filter
ORDER #FF055113
 Original Kohler part. Replaces OEM#s 2405002-S, 2405013-S & 2405010-S.



Price Each \$7.80

Multi-Application Premium Fuel Filter
ORDER #FF6000
 Round in-line filter for 1/4" fuel line. Replaces B&S 298090 and John Deere PT4265, Onan 149-2356, Scag 48057-02, Toro 42-5240. 150 micron element. For engines without fuel pump.



Price Each \$2.05	Price 10+ \$1.85
------------------------------------	-----------------------------------

Echo Vent Assembly
ORDER #MP9607
 Vent assembly replaces Echo #'s 131300-56430, 13130040630 & A356000030. Fits model GT1100, 2000, 2100, 2102, 2103, 2400, SRM-1500, 1501, 2100, 2300, 2301, 2400, 2500, 2501, 2510, 3000, 3800, SRS-2100, PE-2400, PB1000/1010, 2400, ES-2000, SHR-2100.



Price Each \$4.65	Price 10+ \$4.15
------------------------------------	-----------------------------------

Multi-Application Trimmer Fuel Filter
ORDER #FF4995
 Fuel tank filter for mini-saws and most string trimmers with 1/8" pickup fuel line. Replaces Tecumseh 410263, 410245 • Homelite 49422 • McCulloch 216985 • Zama ZF-1



Price Each \$1.70	Price 10+ \$1.50
------------------------------------	-----------------------------------

Briggs & Stratton Fuel Filter
ORDER #FF7998
 Replaces Briggs & Stratton #493629 and #691035. 60 micron filter for selected engines with fuel pumps.



Price Each \$2.25	Price 10+ \$1.99
------------------------------------	-----------------------------------

Stihl Trimmer Fuel Filter
ORDER #FF7298
 Fuel Pick-up Assembly replaces Stihl 1115-350-3503. Fits models 045 and 056.



Price Each \$5.10	Price 10+ \$4.50
------------------------------------	-----------------------------------

Multi-Application Premium Fuel Filter
ORDER #FF1349
 Round in-line filter. Replaces B&S 394358 and Toro 566360 and Simplicity 173206. For 1/4" nipple. 75 Micron element. For engines with fuel pumps.



Price Each \$2.15	Price 10+ \$1.99
------------------------------------	-----------------------------------

Kubota Cartridge Fuel Filter
ORDER #S120-670
 Replaces Kubota #15231-43560 and Woods #70666. 1/2" ID x 1-1/8" OD x 3-3/8" length.



Price Each \$2.85	Price 10+ \$2.35
------------------------------------	-----------------------------------

Kohler and Toro Fuel Filter
ORDER #S120-914
 Replaces Kohler 2405002, Toro 83-1320 & 94-2690. Fits 1/4" ID fuel line 10 micron. Fits Toro Greensmaster 3, 300, 3000, 3100 and Sand Pro. Metal construction.



Price Each \$6.20	Price 10+ \$5.50
------------------------------------	-----------------------------------

Kubota Fuel Filter
ORDER #FF9146
 Fuel filter replaces Kubota #12581-43012, Toro #18-1520, & Grasshopper #101005. Fits large horse power models. 10 micron. Fits 5/16" fuel line.



Price Each \$4.50	Price 10+ \$3.85
------------------------------------	-----------------------------------

OIL TRANSMISSION FILTERS

Kawasaki Oil Filter

Mow More Catalog #KA71

Newer Smaller version filter for most Kawasaki engines. Replaces O.E.M.#s 49065-2078, 49065-2062, 49065-2071, 49065-2057. Also replaces Cub Cadet 490-201-0001, Gravely 21527900, 43594, 21480600, 20777000, John Deere #AM107423, AM101054, Onan 122-0737, 122-0737-03, Tecumseh 36262, Toro NN10684, Woods 72859, Snapper 77355. Thread size 3/4"-16", O.D. 2-11/16", Ht 2-7/8", 25 micron.

We now also carry the Original Kawasaki OEM filter # 49065-2078 Our part # is S054-067. *Call for Price*

Price Each
\$5.60

Price 12+
\$4.35

Price 36+
\$3.35

Kohler Oil Filter

Mow More Catalog #KO09

Large version filter. Replaces Kohler O.E.M.# 5205002, 491056. Kohler oil filter for 14, 16, 18, 20 & 26 HP. Magnum engines. Also fits CH11-15, CV11-22, M18-M20, MV16-20 & K582. Also fits B & S 491056, Vanguards & twin cylinder engines, Case C26191, Gravely 042366, John Deere AM101207(w/ Kohler engine), Toro, NN10147, Woods 70939. Thread size 3/4"-16", O.D. 3", Ht 3-7/16", 25.5/27 micron.

We now also carry the Original Kohler OEM filter # 5205002(S) Our part # is S055-109 *Call for Price*

Price Each
\$4.75

Price 12+
\$4.20

Price 36+
\$3.50

Kohler Oil Filter

Mow More Catalog #KO16

Replaces O.E.M. #1205001, 1205001S Filter fits CH18-25, CV. Kohler short oil filter for 18 and 20 HP engines and 25 HP Command Engines. Also fits CV-135.

Price Each
\$6.15

Price 12+
\$5.35

Price 36+
\$4.55

Multi-Fit Transmission Filter

Mow More Catalog #EX9361

Replaces O.E.M.# Exmark 513211, 1-513211 & 109-4180. Also fits Bobcat 2188179, Buntun PL7488, Dixie Chopper 60105, 68140, Dixon 5565, 7252, 501, 502, 5501, 5017, 5020, 5023, 5421, 5601, Encore 423063 & 423361, Ferris 22028, Honda 25641-VE4-003, Husqvarna 539102606, Kees 102606, Toro E63-3750 & 23-9740. Transmission filter has 3/4"-16 thread, 10 Micron, 3-1/2" Height, 3" O.D.

Price Each
\$12.35

Price 12+
\$11.55



MOW MORE
LANDSCAPE SUPPLIES, INC.

Don't See Your Filter?

Call Us With the O.E.M. #

1-800-866-9667

Kubota Oil Filter

Mow More Catalog #S120-360

Replaces Kubota O.E.M.# 70000-15241, 70000-74034. 27 Micron. Also fits Honda 15400-679-033, 15410-MBO-000, 15410-MJO-405, 15400-POH-305PE, Honda code 0801597, 1395417, 3481355, 5038781, 6424329 IEM5000 water cooled engines. Also Howard Price 05364 for 1260 w/Yanmar engines, Hustler 785634, John Deere AM101378, Kubota 70000-15241, 70000-74034 and Yanmar 129150-35150. 27 micron

Price Each
\$8.20

Price 12+
\$7.60

Scag Transmission Filter

Mow More Catalog #SC8631

Replaces Scag O.E.M. #48462-01, Great Dane D18094, John Deere AM131053, Snapper 27164 & 7027164, Toro 67-8110 & Wright 34490002. Hydro filter - 10 micron.

Price Each
\$11.25

Price 12+
\$10.45

Briggs & Stratton Oil Filter

Mow More Catalog #BS932

Replaces Briggs O.E.M.# 492932, 492932S, 492056, 696854, and Tecumseh 36563. Fits Briggs 14 & 18 HP Vanguard engines Also fits 15-17 HP Intek engines. Thread size 3/4"-16", O.D. 2-15/16", Ht 2-1/4", 25/30 Micron

Price Each
\$6.75

Price 12+
\$5.60

Scag Transmission Filter

Mow More Catalog #SC9380

Replaces O.E.M. #48758. Also fits Steiner and Land Pride. Thread size 1"-12, mounting seal OD 2-3/4". OD 3-11/16", height 5-1/4" 10 micron

Price Each
\$10.70

Price 12+
\$9.25

Hydro Gear Oil Filter

Mow More Catalog #HG12374

Replaces Hydro Gear O.E.M.#'s HG52114. Fits transmission model ZT2800. Also replaces Scag HG52114, fits Freedom Z, Exmark 109-3321 and Hustler 768341 and 600976



Price Each
\$12.99

Price 12+
\$11.99

Blade Spacer

Mow More Catalog #DP1191
Replaces Ransomes/Bobcat 64163-12, Buntun PL0617, Exmark 303164, 1-323539, Scag 43278 & 43038, and Snapper/Kees 76436 & Ferris 1541477.
ID- 5/8", OD- 1", Thickness- 1/4"



Price Each \$1.45

Grease Cap

Mow More Catalog #MP10665
Replaces Scag #481559.
Also fits Dixie Chopper #10220, Gravely 20655400, Husqvarna 539102535, Lesco 706347 and Toro 1-543513
dust cap for 1" ID bearings



Price Each \$2.20

Quick Pin

Mow More Catalog #CYS2226
3/16" quick pin.
Replaces Ransomes/Bobcat 6417305, 6417302, Exmark 809006 and Kees 903798



Price Each \$1.60

Exmark Damper

Mow More Catalog #EX9972
Shock Damper replaces EXMARK 103-2913, 103-4079, 109-2339 and 1-523027. Also Fits TORO 103-4079 Fits Lazer Z. 5/16" diameter hole tooth ends. 7" closed length, 11" extended length



Price Each \$32.60

Exmark Throttle Control

Mow More Catalog #TC12218
Replaces Exmark 1-633696.
Fits Metro HP, Turf Tracer, Viking, Lazer & Turf Ranger models with OEM# 1-633696.
Conduit 54", Inner wire 56-1/4"



Price Each \$16.05

Scag Blade Bolt and Nut

Mow More Catalog #DP8343
Replaces Scag 04001-41 & Ferris 1525019-76, Encore 100353 & Wright 11990007.
Fits 32", 40", 48", 52", 61" and 72" mowers.
5/8" x 9-7/8" overall length



Price Each \$5.95

Nut for Bolt Above
Order #DP8343N...**\$0.80 each**

Scag Brake Band

Mow More Catalog #BB587
Replaces Scag #48210. For 36", 40", 48", 52", & 61" midsize mowers.
Also fits Exmark #513048, Encore #363176, Snapper #17048 & Jacobsen #182222



Price Each \$14.60

Scag Bushing

Mow More Catalog #DBU5713
Replaces Scag 48100-01. Used on our CYS8189 support arm, Scag 46082 support arm. Also fits Encore 363007.
Also replaces Velke VPIVOTBUSH.
ID- 7/8", OD- 1-1/8", Height- 1", Flange OD- 1-1/2"



Price Each \$2.95

Scag Clamping Knob

Mow More Catalog #MP10358
Three prong clamping knob.
3/8" - 16 Male thread clamping knob.
Replaces Scag #481625-01



Price Each \$2.55

Scag Caster Yoke Spacer

Mow More Catalog #CYS8190
Replaces Scag 4303701.
Used with our CYS8189 support arm.
Also replaces Wright 13990008, Exmark 303314 & Encore 363006.
ID-7/8", Thickness-1/2", OD-1-1/2"



Price Each \$2.00

Scag Steering Cable

Mow More Catalog #TC9694
Steering cable replaces Scag 48828 & 48042.
Fits 61" and 72" cut riders, models ST17KA and 19KH. 67-1/2" length



Price Each \$21.00

Walker Deck Bushing

Mow More Catalog #DP11833
Walker deck pin bushing replaces Walker OEM# 5740-2.
5/8" ID x 1" OD.
Fits 36, 42, 48 & 54" decks.
Sold individually. 4 Required Per Unit



Price Each \$2.95

Spindle Bearings

Exmark Spindle Bearing

Mow More Catalog #S230233
Replaces Exmark #103-2477
Fits 60" and 72" Lazer Z XP.
Bearing #RA100RR7.
REF. NO.: CS203ASSY



Price Each
\$19.75

Exmark Spindle Bearing

Mow More Catalog #SB8488
Replaces Exmark #513016.
Also fits Dixie Chopper 30218,
Dixon 1701 & 539115279, John Deere 8597,
Grasshopper 120081, Bobcat 38348-01,
Hustler 077123 & Woods 70006.
Bearing #RA100RR
ID-1", OD-2", Height-27/32"



Price Each
\$16.70

Scag Spindle Bearing

Mow More Catalog #S230-023
Replaces Scag OEM# 481022.
New style taper bearing.
Bearing #L44649
and #L44610



Price Each
\$13.90



Don't See Your Parts?

Call Us With the O.E.M. #

1-800-866-9667

Idler Pulleys

Scag Pump Drive Idler Pulley

Mow More Catalog #SCP10414
Replaces Scag #48181.
Fits models SSZ, SWZ
and Turf Tiger.
5/16" offset reducer bushing.
Also replaces AYP 101344L.
ID 3/8", OD 5", Height 7/8"



Price Each
\$11.95

Scag Deck Idler Pulley

Mow More Catalog #SCP269
Replaces Scag 48269 & 482416.
Deck Idler on 40" and 48" decks.
ID- 3/8", OD- 5-7/8",
Height- 1-1/4"



Price Each
\$14.99

Exmark Idler Pulley

Mow More Catalog #EXP9772
Replaces Exmark 603805.
Deep V Idler pulley. Fits Lazer
Z. ID 11/16", OD- 5", Height
7/8"



Price Each
\$15.99

Exmark Idler Pulley

Mow More Catalog #EXP9864
Idler pulley replaces Exmark
1-633109. Fits 52", 60", &
70" Deck belts on Lazer-Z
units. ID-5/8",
OD 6-3/4", Height-1-3/16"



Price Each
\$18.00

Spindle Assemblies

Scag Spindle Assembly

Mow More Catalog #SH5722
Replaces Scag 46020 & 46400, Ferris
1530301, Lesco 050194, and Wright
71460007. Uses our replacement bearing
SB7178. For 1994 and older Scag.
7-3/16" shaft length, 1" shaft OD



Price Each
\$67.99

Scag Spindle Assembly

Mow More Catalog #SH9153
Replaces Scag O.E.M. #46631 &
461663. Fits on models 1995 and
newer. New style with taper roller
bearings. Cast iron assembly w/
grease fitting



Price Each
\$86.99

BEARINGS • PULLEYS • SPINDLES

TIRES and TUBES

Smooth/Slick 11 x 400 - 5 • 4 Ply Tubeless

ORDER #CT9494

Provides wide surface weight distribution for increased steering and traction.



Price Each \$27.35

Price 4+ \$25.25

Turf Saver Tread 9 x 350 - 4 • 4 Ply Tubeless

ORDER #T118

Broad shoulder design provides excellent traction with minimal turf wear.



Price Each \$13.00

Price 4+ \$12.40

Smooth/Slick 9 x 350 - 4 • 4 Ply Tubeless

ORDER #T98

Replaces Scag #48307-02 and #481774 Provides wide surface weight distribution for increased steering and traction.



Price Each \$11.95

Price 4+ \$10.95

Smooth/Slick 13 x 500 - 6 • 4 Ply Tubeless

ORDER #CT0289

Provides wide surface weight distribution for increased steering and traction.



Price Each \$31.50

Price 4+ \$29.25

Turf Saver Tread 13 x 650 - 6 • 4 Ply Tubeless

ORDER #T83

Broad shoulder design provides excellent traction with minimal turf wear.



Price Each \$22.95

Price 4+ \$21.95

Smooth/Slick 13 x 650 - 6 • 4 Ply Tubeless

ORDER #T145

Provides wide surface weight distribution for increased steering and traction.



Price Each \$22.50

Price 4+ \$20.75

Turf Saver Tread 15 x 600 - 6 • 4 Ply Tubeless

ORDER #T121

Broad shoulder design provides excellent traction with minimal turf wear.



Price Each \$25.85

Price 4+ \$24.20

Turf Saver Tread 16 x 650 - 8 • 4 Ply Tubeless

ORDER #CT28

Broad shoulder design provides excellent traction with minimal turf wear.



Price Each \$39.30

Price 4+ \$37.10

Turf Saver Tread 16 x 650 - 8 • 4 Ply Tubeless

ORDER #T122

Broad shoulder design provides excellent traction with minimal turf wear.



Price Each \$31.50

Price 4+ \$29.50

TurfMaster Tread 18 x 850 - 8 • 4 Ply Tubeless

ORDER #CT9188

Deep tread design, a broad footprint for traction and contoured shoulder minimizes turf wear.



Price Each \$71.95

Price 4+ \$67.95

TurfMaster Tread 23 x 9.50 - 12 • 4 Ply Tubeless

ORDER #CT9744

Deep tread design, a broad footprint for traction and contoured shoulder minimizes turf wear.



Price Each \$97.95

Price 4+ \$91.95

TurfMaster Tread 24 x 12.00 - 12 • 4 Ply Tubeless

ORDER #CT9283

Deep tread design, a broad footprint for traction and contoured shoulder minimizes turf wear.



Price Each \$110.95

Price 4+ \$102.95

TUBES • VALVE STEMS • FLAT-GARD

Mow More Catalog #	Size	Also Fits	Valve Stem	Price Each	Price 4+
TS862	9/350-4	-	90° Valve Stem (Turned with Rim)	5.95	5.50
T253	410/350-4	10.5 x 450-4	L - Shaped Valve Stem	5.35	4.80
TU506	13 x 500-6	-	Straight Valve Stem	7.05	6.50
T488	13 x 650-6	-	Straight Valve Stem	7.05	6.50
T553	480/400 x 8	16 x 500, 550-8, 5-8	Straight Valve Stem	6.95	6.50
TU512	23 x 850-12	23 x 950-12	Straight Valve Stem	20.20	19.10



Valve Stems Long Stem, Core and Cap (TR-413)
ORDER #VS4

Price Each \$1.30

Valve Stems Short Stem, Core and Cap (TR-412)
ORDER #VS8

Price 10+ \$0.95

Flat-Gard Tire Sealant

ORDER #FGTS101

Flat-Gard is a complex non-latex based chemical formula containing a high concentration of special fibers and rubber particles suspended in a fluid base. After a puncture occurs the fibers surround and cling to the penetrating object preventing air loss and sealing the hole. **16 ounce bottle**



Price Each \$7.05

Price 12+ \$6.50



Flat Gard
The tire sealant that really works!

Flat-Gard is also available in 1 Gallon and 5 Gallon Sizes

Deck Wheel Exmark and Toro

ORDER #WEX6917

Replaces O.E.M. # 603299, 682730. Wheel size 5 x 2.75, Deck wheel. 2-1/2" offset hub. ID 5/8", width 2-3/4", height 5" Plastic deck wheel for 38", 40", 50", & 60" cut decks. Uses our WB8586 wheel bushing, our WB10007 complete anti-scalp roller hardware kit or WB9874 wheel bolt



Price Each \$7.00 **Price 10+ \$6.75** **Price 30+ \$5.90**

Toro Wheel Bolt for Mow More #WEX6917

ORDER #WB9874

Replaces Toro #99-2842. Fits Toro Z Master Anti-Scalp Roller Wheel Bolt. OD-5/8" Length - 4-1/4"



Price Each \$3.50

Hardware Kit for Mow More #WEX6917

ORDER #WB10007

Replaces Exmark #603602 Bushing, #98-5961 Bolt, #3290-357 Nut, #373034 Pivot Washer and #98-5975 Spring Washer. Kit consists of 1 each of the above items



Price Each \$10.50

Deck Wheel Exmark

ORDER #WEX12015

Anti scalp roller deck wheel only. Replaces Exmark OEM# 103-8415. Fits Triton decks. 5/8" ID, 3-1/4" width, 5" HT



Price Each \$7.20 **Price 10+ \$6.95**

Exmark hardware Kit for WEX12015

ORDER #WEX12016

Hardware kit for our Exmark deck wheel WEX12015.



NEW!
Price Each \$10.95



Don't See Your Wheels?

Call Us With the O.E.M. #

1-800-866-9667

Solid Flat Free Wheel

ORDER #WEX0286

Replaces O.E.M. # 103-0065, Wheel size 13x650-6, Carlisle Reliance Solid Flat Free Wheel Assembly. Replaces Exmark #103-0065, Scag # 482504 & Toro # 633971. 13x650-6 Reliance tire mounted on a 6x4.50" steel wheel. 7.25" centered hub with 3/4" cups pressed in for tapered roller bearings. Painted white. Order bearings WEX9944 separately



Price Each \$99.99

Wheel Bearing Kit

ORDER #WEX9944



Bearing kit for our WEX0286, WEX0288 and 506DC4-562SM wheels. Replaces O.E.M.#633585, 633580, 633581, 254-78, 254-79 ID=3/4", OD=1-25/32". Includes (2) bearings #633585, (2) seals #633580, (2) spacers #633581. 1 kit fits 1 wheel.

Price Each \$13.65

Wheel Bearing Kit

ORDER #WB5812



Open cage roller bearing, replaces Bobcat #38273 & 38274, Scag 48006-07 and 48006-06 5/8"IDx1-3/8"ODx3-1/4" length with flanged bushings Used on 9x350x4 front caster wheels

Price Each \$6.75

Solid Flat Free Wheel

ORDER #WEX0288

Replaces Exmark O.E.M. #s 103-0064, 103-3785, Ferris #22631S, Scag # 482503, Toro #633582 & Wright 72460004. Wheel size 13x500-6, Flat Proof. Carlisle Reliance Flat Proof tire on a 6x3.25" wheel. 5.625" centered hub with 3/4" cups pressed in for tapered roller bearings. Painted white. Order bearings WEX9944 separately



Price Each \$85.99

Deck Wheel Scag

ORDER #WSC0225

Replaces O.E.M. #481632. ID=3/8", Width=3", Height=4-1/2". Anti-Scalp Wheel Fits most Scag units including Turf Tiger. Includes bushings



Price Each \$10.95

Wheel Scag

ORDER #WSC01

Replaces O.E.M. # 4800601, 48307, Wheel size 9x350-4, Front caster wheel assembly 9x350-4, 4-ply smooth tire and tube, 4" centered 3-piece rim with 5/8" open cage roller bearing (included) and zerk fitting, painted Scag gold. (Uses our WB5812 open cage bearing kit or WB7780 semi-sealed bearing kit, as replacements).



Price Each \$37.95

Price 4+ \$33.95

Deck Roller Wheel Scag

ORDER #WSC210029

Replaces O.E.M. #482295, Wheel size 3"x3.32". Deck roller for Turf Tiger. 3-5/16" centered hub with 11/16" bore

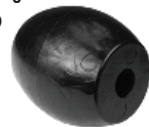

Price Each \$5.60

Solid Flat Free Wheel Scag

ORDER #9354DC-U-SCG

Replaces Scag #48307 & 4800601 Wheel size 9x350-4, polyurethane smooth tire on 1-piece gold wheel with 5/8" open cage roller bearing. Flat Free Tire.



Price Each \$45.99

Solid Flat Free Wheel Velke

ORDER #9354DB-U-V

Wheel size 9x350-4, polyurethane flat free traction tire on 3-piece white wheel with 3/4" open cage roller bearing including spanner bushing. For single wheel Velke



Price Each \$49.99



Premium Oil Filters

Replacement Oil Filters for Most Major Brands



Premium Mower Blades

Proudly Made in the U.S.A. Blades for Most Major Brands



MOW MORE
LANDSCAPE SUPPLIES, INC.

See Us Online www.mowmore.com

WHEELS



Safety Glasses

XTS Alien Style Safety Glasses

XTS stands for Extraterrestrial and it pretty much explains the style. Unlike several similar styles, our XTS frame is substantial and sturdy. It provides a very close fit with the face and can therefore fill the safety requirements of a safety spectacle, including the important side coverage.

Complies with ANSI Z87.1-2003 (+).

	Price Each \$5.60
	Price 5+ \$5.10

TTS Truly Terrestrial Safety Glasses

TTS offers sleek styling, likely to impress today's fashion oriented workers. The close fit and excellent protective features will please employers. TTS in one of Elvex's best selling styles and it is also one of the most economical safety glasses around.

Meets ANSI Z87.1 and CE-EN-166.

	Price Each \$3.95
	Price 5+ \$3.35

Sphere X Safety Glasses

This is one of the boldest safety glass designs to hit the market. Sphere-X offers a unique combination of style, coverage and protection. Dual lens construction (9.75 base curve) allows for excellent optics and extreme coverage.

Complies with ANSI Z87.1-2003 and CE EN-166.

	Price Each \$6.60
	Price 5+ \$5.80

Summit Safety Glasses

The Elvex Summit provides the wide wraparound coverage required for full protection. Adjustable, stylish rubber temples and a mono-lens make it possible to fit these glasses to most faces. All lenses provide 99% UV protection.

Complies with ANSI Z87.1-2003 and CE-EN-166.

	Price Each \$6.60
	Price 5+ \$5.80

Trix Safety Glasses

Trix safety glasses provide style, comfort and economical pricing. Available with clear, gray or silver mirror hard-coated Polycarbonate lens. All lenses provide 99% UV protection. Universal length temples.

Complies with ANSI Z87.1-2003 (Z87+) and CE EN-166.

	Price Each \$4.95
	Price 5+ \$4.25

Ranger Safety Glasses

Elvex Ranger Safety Glasses are loaded with features which translate into a safe, comfortable, and stylish product. Fashionable design allows an uninterrupted field of vision. Polycarbonate lens provides optical clarity and impact resistance. Side and top protection are built in to provide additional safety margin. Nose and ear piece design offers snug and secure fit, even over most prescription glasses. 99% of harmful ultraviolet light is filtered out.

	Price Each \$3.15
	Price 5+ \$2.85

SAFETY EQUIPMENT

Hearing Protection

Elvex Blue is a plug for today's demands. It meets the requirements of both users and safety and health professionals. Excellent attenuation, 32NRR. High level of hygiene. Visually easy to monitor. One size fits all. Easy to insert. Slow expansion time for early insertion. Comfortable low pressure foam. Easy to read instructions, in English, Spanish, and French. Good sound reduction properties.

Uncorded Foam Plug
Each Order #EP201EA...\$0.25/pair
200ct Order #EP201....\$33.50 case

Corded Foam Plug
Each Order #EP211EA...\$0.35/pair
100ct Order #EP211....\$29.99 case

Corded Quattro

NEW!

Each Order #EP412EA...\$1.75/pair
50ct Order #EP412....\$69.99 case



Don't See It?
Call Us
1-800-866-9667

Oil and Lubricants

Mo-Deck ORDER #MD9982

Prevent Clipping Build-up, Prevent Clogging, Spray on underside of mower deck to help the mower cut cleanly and efficiently, saving fuel and wear and tear. 11oz can

Price Each
\$7.50

Price 12+
\$6.95

Price 36+
\$6.40



Grease Cartridge ORDER #GG7896

Premium Red High Temp Grease for spindle assemblies, and more.

14oz tube

Price Each
\$4.99

Price 10+
\$4.25



No Smoke 2 Stroke

- Excellent anti-corrosion performance
- Superior performance with unleaded gas
- Incredible anti-seizure protection
- Remarkably less exhaust port clogging
- Significantly less piston scuffing
- Reduced downtime
- Great results in air cooled engines
- Amazingly low deposit formations
- Safer for the equipment operator
- API air engine oil service classification of TC, Fluidity Grade 3, increased engine life.

No Smoke Two Stroke meets the most severe API air cooled engine oil service classification of TC, and it meets the SAE Miscibility/Fluidity Grade 3. The flash point is 265 degrees F. It is formulated to mix with unleaded gas. No Smoke Two Stroke is a multi-ratio product and gives excellent results in all air cooled two-cycle engines regardless of manufacturer's suggested mixing ratio. Covers all mix ratios 32:1, 50:1, etc.



Freight Charges Apply

6 pack 2.6oz Bottles
Order #NS0266PK **\$9.00**

CASE PACK
48 count
2.6oz Bottles
Order #NS026

Makes **48**
Gallons of Mix
Per Case

Each Case.....**\$60.45/ea**
3+ Cases.....**\$59.40/ea**
5+ Cases.....**\$58.30/ea**
10+ Cases.....**\$56.70/ea**

6 pack 6.4oz Bottles
Order #NS0646PK **\$11.25**

CASE PACK
36 count
6.4oz Bottles
Order #NS06436

Makes **90**
Gallons of Mix
Per Case

Each Case.....**\$60.65/ea**
3+ Cases.....**\$59.55/ea**
5+ Cases.....**\$58.40/ea**
10+ Cases.....**\$56.15/ea**

6 pack 12.8oz Bottles
Order #NS0126PK **\$18.55**

CASE PACK
24 count
12oz Bottles
Order #NS012

Makes **120**
Gallons of Mix
Per Case

Each Case.....**\$61.80/ea**
3+ Cases.....**\$57.30/ea**
5+ Cases.....**\$55.05/ea**
10+ Cases.....**\$51.70/ea**

1 Gallon Jug
Order #NS128
\$21.35 Each

Makes **50**
Gallons of Mix
Per Jug

3+**\$20.80 each**
5+**\$20.20 each**
12+**\$19.10 each**

Assorted Top Sellers

The Budget Debris Bag

ORDER #WE10

16" wide x 14" in length. Secures to mower handle bars with 1/2" webbing straps. Heavy duty weather resistant mesh construction. Color- Black.



Price Each
\$12.35

Price 5+
\$11.80

Parts Assortment

Hair Pin Cotter Assortment

141 Piece Hair Pin Cotter Assortment. From 1/16"x1-3/8" up to 3/16"x3-1/4" sizes



Order #16.....**\$24.60**

Cotter Pin Assortment

555 piece Cotter Pin assortment. From 1/16"x1" up to 5/32"x2-1/2" sizes



Order #11.....**\$25.65**

Electric Starter

ORDER #KO10262

Replaces Kohler #25-098-09, 12-098-03, 25-098-09S & 24-098-01(S). Fits models CH 12.5, 13, 14, 15, 18, 20, 22, 25, 28, CV12.5, 15S, 16, 18, 20, 22, and 25. 9 tooth gear. 30% restocking fee if returned. Match OEM # before ordering.



Price Each
\$142.99

Solenoid

Replaces Kohler OEM# 52-435-02 S & Kawasaki 27010-2122. Fits our KO10262, HO10683, HO10806 & KA10241 electric starters



Order #KO12130.....**\$28.99**

Peerless Transmission

Order #794626A

Many More
Transmission
Models in Stock
www.mowmore.com
1-800-866-9667



O.E.M. #700-070A. Fits some Exmark, Some Scag. Must match 700-070(A) on your original transmission. A restocking fee applies if returned. Picture shown is of a transmission & may not be the exact picture for this transmission

Price Each
\$290.99



Starter Rope 4 Sizes to Choose From

- Red braided premium starter rope
- Heavy duty
- Made in the USA
- High Quality with low stretch core
- Stiffer, more abrasion resistant

#3-1/2-3/32"

200' roll. 3/32" diameter
Fits string trimmers and small 2-cycles

Order #SR-3.....**\$16.25**

#4-1/8"

200' roll. 1/8" diameter
Fits chain saws and large 2-cycles (e.g. Lawnboy)

Order #SR-4.....**\$17.95**

#5-5/32"

200' roll. 5/32" diameter
Fits 4-cycle push mowers

Order #SR-5.....**\$21.95**

#6-3/16"

200' roll. 3/16" diameter
Fits larger 4-cycle engines

Order #SR-6.....**\$26.25**

Blade Care

Economy Blade Balancer ORDER #D827

A quick and inexpensive tool to check blade balance. Balanced blades give your mowers a smoother cut and less wear on equipment!
Compact and easy to use.



Price Each
\$4.55

Blade Balancer ORDER #GMBB32

Blade balancer made of the finest steel with sealed bearings for precision balancing and strong magnets to hold a blade while balancing.



Price Each
\$194.99

Mo-Deck ORDER #MD9982

Prevent Clipping Build-up, Prevent Clogging, Spray on underside of mower deck to help the mower cut cleanly and efficiently, saving fuel and wear and tear. 11oz can



Price Each **Price 12+** **Price 36+**
\$7.50 **\$6.95** **\$6.40**

Ruby Grinder Replacement Stone ORDER #RBG1208

- Ruby (for RBG)
- Diameter 8"
- Thickness 1"
- Center Hole 5/8"

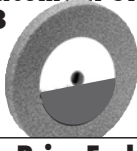

Price Each
\$42.99

Ceramic Grinder Replacement Stone ORDER #RBG2208

- Blue (for RBG)
- Diameter 8"
- Thickness 1"
- Center Hole 5/8"

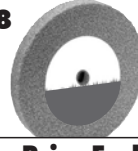

Price Each
\$52.99

Ceramic Grinder Replacement Stone ORDER #RBG2210

- Blue (for RBG)
- Diameter 10"
- Thickness 1"
- Center Hole 3/4"

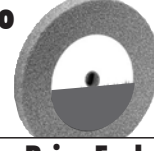

Price Each
\$79.99

Blade Grinders

R.B.G. Grinder Commercial Model ORDER #RBG1012C

Super Heavy Duty 1 HP Commercial duty motor, 12" Ceramic Wheel, Extra large frame, Sharpens all blades, Most heavy duty grinder Manufactured by R.B.G.



Large landscapers, municipalities, repair shops- This is the Grinder for You!

1 Year Warranty
Suggested List \$1,065.00

Freight Charges Apply on Grinders

Price Each
\$899.99

Optional Accessories:

Grit Collector

For a safer, cleaner shop add a grit collector to your grinder. The grit collector provides a simple method of containing flying sparks and grit. Easy to attach and can be reversed for left hand or right hand sharpening.

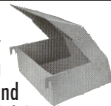

Order #RBG10044.....**\$53.99**

Mulching Plate Adaptor

Convert your blade grinder to a mulching blade grinder. Easy to install and easy to remove (no tools necessary)



Order #RBG10075.....**\$37.99**

Diamond Wheel Dresser

Clean and restore sharpness of a wheel that has become loaded with the material being ground. Increases wheel life and performance.



Order #RBG10043.....**\$104.99**

R.B.G. Grinder Commercial Model ORDER #RBG3410-C

R.B.G. professional model. The same quality features as the BG121 plus... 3/4 HP Reversible motor, Bell front motor (no arbor) extends the hardened ceramic wheel to accommodate the longer bevels being used on the newer style blades (also sharpens extra long mulching blades with optional mulching plate). 10" ceramic wheel, Larger steel table, "The Professionals Choice"



1 Year Warranty
Suggested List \$749.00

Freight Charges Apply on Grinders

Price Each
\$629.99

Optional Accessories:

Grit Collector

For a safer, cleaner shop add a grit collector to your grinder. The grit collector provides a simple method of containing flying sparks and grit. Easy to attach and can be reversed for left hand or right hand sharpening.

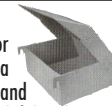

Order #RBG3440.....**\$50.99**

Mulching Plate Adaptor

Convert your blade grinder to a mulching blade grinder. Easy to install and easy to remove (no tools necessary)



Order #RBG1691.....**\$32.99**

Diamond Wheel Dresser

Clean and restore sharpness of a wheel that has become loaded with the material being ground. Increases wheel life and performance.



Order #RBG10043.....**\$104.99**

R.B.G. Grinder Standard Model ORDER #BG121

Save time and money... sharpen your own blades! 1/2 HP. Reversible motor, 8" Hardened Ruby Wheel. Fast bevel adjustment, Grinds right or left handed blades, Sharpen standard and mulching blades (with optional mulching blade kit), Steel work table, Guarded wheel, Designed to be the highest quality blade grinder available with economy in mind.

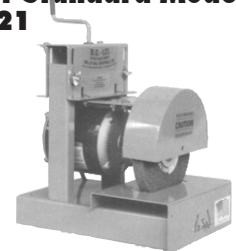

1 Year Warranty
Suggested List \$509.00

Freight Charges Apply on Grinders

Price Each
\$425.99

Optional Accessories:

Grit Collector

For a safer, cleaner shop add a grit collector to your grinder. The grit collector provides a simple method of containing flying sparks and grit. Easy to attach and can be reversed for left hand or right hand sharpening.



Order #RBG1240.....**\$48.99**

Mulching Plate Adaptor

Convert your blade grinder to a mulching blade grinder. Easy to install and easy to remove (no tools necessary)



Order #RBG1245.....**\$30.99**

Diamond Wheel Dresser

Clean and restore sharpness of a wheel that has become loaded with the material being ground. Increases wheel life and performance.



Order #RBG1341.....**\$89.99**

BLADE CARE

V-BELTS

OEM Replacement Belts / Specialty designed belts to meet OEM specifications

PowerPlus V-Belts - Kevlar Reinforced

PowerPlus replacement belts are specifically designed and produced to withstand the riggers of tough, frequent usage in professional lawn equipment. PowerPlus belts with a Kevlar cord withstand severe shock load and provide generally longer life than standard duty belts. They are oil and heat resistant. (Kevlar is a trademark of E.I. DuPont de Nemours and Company) These belts are constructed with high strength Kevlar Cord - a material so strong it's used to make bullet-proof vests. Increased flexibility and the ability to withstand severe clutching action makes our Heavy Duty PowerPlus Belts the only choice for extra heavy duty jobs.

Order #	Description	Replaces OEM #	Price
Bobcat			
21" Mower - M214SP (older models)			
PPB0730	Jackshaft	78030	5.50
PPB0731	Jackshaft to wheel	78031	6.65
Variable Speed Transmission (32", 36", 48", 52" older models)			
PPB016	Transmission Belt	38016N	7.30
P38016N	Transmission OEM Belt	38016N	8.45
B41COG41	Wheel Drive - Single V - OEM	38017N	14.15
PPB030	48" - Main Blade Belt	38030N	19.10
P38030N	48" - Main Blade Belt - OEM	38030N	21.35
PPB031	48" - Short Deck Belt	38031N	10.45
P38031N	48" - Short Deck Belt - OEM	38031N	11.80
PPB039	32" Main Deck Belt	38039N	16.85
PPB0111	36" Main Deck Belt	38111	17.45
P38111	36" Main Deck Belt - OEM	38111	18.00
B0382	Dual Wheel Drive Belt - OEM	38185/38249	23.60
5 Speed Gear Drive (Peerless) (36" & 48" older models)			
PPB031	48" Short Deck Belt	38031N	10.45
P38031N	48" Short Deck Belt- OEM	38031N	11.80
PPB030	48" Main Blade Belt	38030N	19.10
P38030N	48" Main Blade Belt- OEM	38030N	21.35
PPB08804	36"/48" Engine/Trani- OEM	38211	7.85
P38234	36" Engine/Blade Belt- OEM	38234	20.20
B0212	36"/48" Dual Wheel Drive- OEM	38212	27.55
Newer Models- See Descriptions:			
B08803	48" Hydro-Deck Belt- OEM	38440	17.05
B08808	61" Rider- Eng/Hydro Pump-OEM	2188128	12.95
B08809	48" Gear Drive Eng/Deck- OEM	38442	17.05
B08810	'94-'96 Wheel Drive Belt-OEM	38523	28.10
B08811	Gear Drive Mowers- Trani Belt-OEM	128099	7.85
B038389	Deck Cross Drive Belt on 36" XM Series - OEM	38389	15.70
B038439	Gear Belt for 48" cut XM Series - OEM	38439	14.60
B038458	Hydro 36" cut XM Series - OEM	38463 38458	16.85
B0128003	Cutter Deck Belt for ZTR Rider 61" - OEM	128003	29.95

Order #	Description	Replaces OEM #	Price
Bunton			
Flat Front Deck Machines (32", 36", 48", & 52"):			
PPBU21	40" Deck Belt	PL0021	20.20
PPBU11	32" & 36"- Engine/Blade Belt	PL0511	11.55
BU7915	Wheel Drive Belt-Cogged-OEM	PL0619	14.60
PPL0643	52" Blade to Blade Belt-OEM	PL0643	13.50
PPBU813	48" Engine to Blade Belt	PL4813	6.75
BU48	Variable Speed Belt-OEM	PL0848	14.60
PPBU861	52" Engine to Blade Belt	PL0861	9.55
BU443	48" Blade to Blade Belt- Cogged	PL1443	15.70
PPBU511	36" Engine to Blade Belt	PL4511	11.55
New Style with Serial Prefix "SS" (36", 48", 52", & 61") :			
PPBU643	36" & 52" Blade to Blade Belt	PL0643	7.85
PPL0643	36" & 52" Blade to Blade Belt- OEM	PL0643	13.50
PPBU861	52" Engine to Blade Belt	PL0861	9.55
PPBU511	36" Engine to Blade Belt	PL4511	11.55

Order #	Description	Replaces OEM #	Price
Bunton cont.			
New Style with Serial Prefix "SS" (36", 48", 52", & 61") :			
PPBU813	48" Engine to Blade Belt	PL4813	6.75
BU275	Double Wheel Drive Belt-OEM	PL4275	27.00
PPBU039	Variable Speed Belt	PL5039	8.45
Hydro Drive (36", 48", 52", 61") :			
BU734	48" Blade to Blade Belt	PL4734	14.60
BU7912	48" Engine to Blade Belt- OEM	PL4732	24.70
PPBU643	36" Blade to Blade Belt	PL0643	7.85
PPL0643	36" Blade to Blade Belt- OEM	PL0643	13.50
BU519	61" Blade to Blade Belt	PL8519	27.00
ZTR 60" Cut:			
BU332	60" Deck Belt for ZTR Mower	PL7332	33.70
BU436	50" & 60" Engine to Deck Belt	PL7436	24.70
Cub Cadet			
CC10782	42" Deck Belt-2000 Series-models 190-142-OEM	954-3073	20.80
CC10830	38", 42" & 48" PTO Deck Drive Belt-models 70,86,123,169-OEM	490489-R2	19.10
Dixie Chopper			
Chain Drive & Hydro Drive (50", 60", & 72" ZTR's):			
DC30202	Engine to Deck Belt	30202	16.05
DC30203	50" Deck Belt	30203	25.85
P302360	60" Deck Belt - OEM	302360	31.45
DC68082	Engine to Deck Belt - OEM	68082	24.20
DC68162	Deck Belt Fits 72" Cut - OEM	68162	38.20
DC10814	Engine to Deck Drive Belt - OEM	9907B84	30.35
DC10029	Deck Belt for 50" & 60" Cut (B80) - OEM	65080	24.70
DC20256	Engine to Transmission Belt - OEM	20256	13.50
DC9907B41	Engine to Transmission Belt - OEM	9907B41	13.50
DC63204	Engine to Transmission Belt - OEM	63204	14.10
DC30204	Engine to Deck Belt - OEM	30204	22.45
DC9907B85	Engine to Deck Belt - OEM	9907B85	29.20
DC9907B112	Deck Belt - OEM	9907B112	33.70
DC9907B130	Deck Belt - OEM	9907B130	38.20
DC9907B57	Pump to Engine Belt - OEM	9907B57	22.45
DC9907B92	Engine to Deck Belt - OEM	9907B92	38.20
DC9907B94	Deck Belt - OEM	9907B94	40.45

Order #	Description	Replaces OEM #	Price
Dixon			
PPDI11	ZTR 421, 424, 426 -Blade Belt	6111	16.85
PPDI09	ZTR 421, 424, 426 -Deck Belt	6109	12.75
P6109	ZTR 421, 424, 426 -Deck Belt-OEM	6109	14.60
PPDI39	ZTR 421, 422 -Drive Belt	1539	10.50
PPDI12	ZTR 301, 302, 308, 311-Blade Belt	2412	15.70
PPDI69	ZTR 308, 311, 425 Drive Belt	2469	8.45
PPDI61	ZTR 425 Blade Belt	6361	19.10
PPDI860	Drive Belt- Fits model 5421	1860	10.50
P1714	Drive Belt-Fits T Box-50" Mower-OEM	1714	9.55
PPDI650	Engine to Trani Belt- OEM	7650	13.00
PPDI300	Models 5421 & 5422-OEM-99.82"	1300	31.45
DI8912	Models 5421/5422-T Box to Hydro-OEM	1765	9.00

www.mowmore.com

V-BELTS

Order #	Description	Replaces OEM #	Price
Snapper cont.			
Variable Speed Walkbehinds:			
SK053	36" thru 61" Pro Wheel Drive Double V Belt-OEM	17053	40.45
Snapper ZTR (Models Z1202B, Z1402K, Z1802K, Z2002K):			
PPSN779	42" & 48" Engine to Deck Belt	79779	18.00
PPSN777	48" Deck Belt	79777	16.85
P79186	60" Deck Belt-OEM	79186	16.85
P79781	60" Engine to Deck Belt-OEM	79781	15.70
Snapper Riders:			
SN236	33" Engine to Blade Belt-OEM	18236	11.25
Toro			
Walkbehinds (36", 44" & 52"):			
PPT0530	36" Blade to Blade Belt	513530	11.25
PPT0160	44" & 52" Blade to Blade Belt-OEM	271160	30.35
PPT0750	36" & 44" Engine to Blade Belt	542750	14.10
P542750	36" & 44" Engine to Blade Belt-OEM	542750	14.60
PPT0660	52" Engine to Blade Belt-OEM	557660	15.70
PPT0670	36", 44", 52" Engine to Transmission Belt	269670	7.30
TO824110	Pump Drive Belt for Hydro Walkbehinds	82-4110	7.85
TO290	Wheel Drive-Double V Belt - OEM	514290	29.30
TO514291	Wheel Drive Belt - Double V - OEM	514291	35.30
TO1048152	Drive Belt - Traction	104-8152	32.99
21" Mowers:			
TO8887	Models 20624,20684,20695-Blade Brake Belt	420884	7.85
PPT0505	Drive Belt-21" Self Propelled -OEM	54505	6.75
PPT0070	21" Recycler	368070	6.75
Edger:			
PPT0320	Fits 2-3.5 HP Edgers	520320	6.75

Order #	Description	Replaces OEM #	Price
Toro cont.			
Riders:			
TO1057790	Drive Belt - Fits Z587, 60" deck - OEM	105-7790	95.99
TO1058783	Deck Belt - fits Z Master, 60" deck - OEM	105-8783/ 108-4071	89.99
TO994647	Engine to Deck Belt- Fits 62" Z-Master	994647	41.55
PPT0160	44" & 52" Blade to Blade Belt -OEM	271160	30.35
TO260	62" Blade to Blade Belt -OEM	446260	29.20
P448990	52" Groundmaster Torque Belt -OEM	448990	29.20
PPT0890	72" Blade to Blade Belt	210890	14.60
P210890	72" Blade to Blade - OEM	210890	27.00
TO265161	72" Deck Belt Z Master - OEM	570240	57.30
TO265157	52" Blade Belt Z Master - OEM	993904	44.90
TO983780	Fits 52" Z Master Riders - OEM	98-3780	29.20
TO265158	72" Engine to Deck Belt Z Master - OEM	994627	35.30
Walker			
PPWA11	M36-42 GHS PTO Belt	52311	7.85
PPWA41	M36-42-PTO Side/Model C-Engine to Gear Box	52341	7.85
WA30	Engine to Blower-Model C -Cogged-OEM	6230	16.30
WA31	PTO Belt-Gear to Hydro-Model T	6231	9.00
WA72	3 Sided Belt	7230	33.70
WA71	Belt	7231	9.00
PPWA232	Belt	7232	6.75
WA34	Blower Belt Model T-OEM	7234	9.00
WA35	Model T-Ground Drive Belt-OEM	7235	10.15
WA7248	Ground Drive Belt - Fits Hydros after 1996-OEM	7248	11.75
WA8230	PTO Drive Belt - Fits T Models - Triple Belt-OEM	8230	35.30

FREE SHIPPING!

ON ORDERS OF \$250.00 OR MORE

Excluding oil and blade grinders.

www.mowmore.com



GET THE CORRECT PART EVERY TIME

Don't know what you need? DON'T GUESS!

Just match the OEM # of the part from your owner's manual to the column in our catalog labeled "REPLACES OEM #".

If they match - YOU KNOW YOU HAVE THE RIGHT PART!

Get the right part, the first time.

Mail/Fax Order Form

Domestic

Please Mail This Order Form To:
MOW MORE LANDSCAPE SUPPLIES, INC.
 P.O. Box 342
 Lancaster, New York 14086

Fax: 716-937-3155
 Phone: 1-800-866-9667
 web site: www.mowmore.com

UPS Shipments must have a street address. Please provide a daytime phone number.
Ship To:
 Company _____
 Attention _____
 Street Address _____
 City/State/Zip _____
 Daytime Phone _____

Please send additional order forms
Please fill in the customer number and ad code from address label.

Minimum Order is \$25.00

Free shipping on orders over \$250.00 (excluding oil and grinders.) If order is under \$250.00, shipping will be added to credit card orders, if paying by company check or money order, please call for shipping charges.

PART NUMBER	QUANTITY	DESCRIPTION	UNIT PRICE	TOTAL PRICE

PAYMENT METHOD **Minimum Order is \$25.00**

COMPANY CHECK (if under \$125.00) **MONEY ORDER** (if over \$125.00)
 VISA **MASTERCARD** **AMERICAN EXPRESS**
 DISCOVER **C.O.D.** (money order only if over \$125.00) **NO PERSONAL CHECKS**

Credit Card Number
 Credit Card Billing Address _____
 _____ CVC # _____
 Signature _____ Expiration Date _____
 Please print name as it appears on card _____

SUBTOTAL
If order is under \$250.00 and mailing in payment, please call for shipping charges SHIPPING
C.O.D. ADD \$9.00/BOX
SUBTOTAL
SHIPMENTS INSIDE NY ADD 8-3/4% SALES TAX
TOTAL AMOUNT
AMOUNT ENCLOSED, if any

Should all items listed not be available at this time, please hold my order and ship when complete.

* If tax exempt in NY, enter number and enclosed TE Certificate

GET THE CORRECT PART EVERY TIME

No Need To Guess!

Simply match the OEM # of the part from your owner's manual to the OEM column in our catalog. If they match - You know you have the right part!

Get the right part, the first time.

OEM names and part numbers are used for reference only

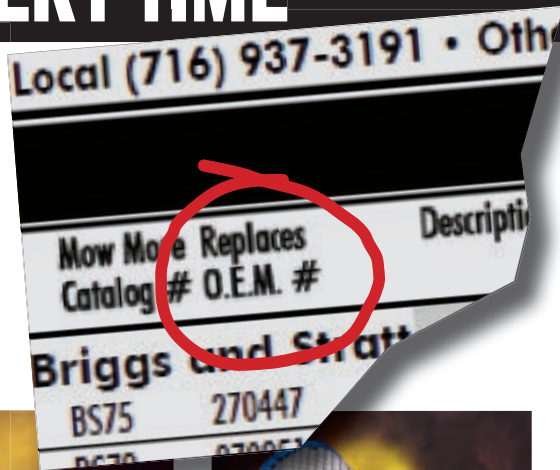

FUEL FILTERS
Briggs & Stratton, Kawasaki, Kohler and More...
Page 23



LUBRICANTS
Two-cycle oil, Lithium Grease, Cleaners and More...
Page 30



OIL & TRANSMISSION FILTERS
Kawasaki, Kohler and More...
Page 24



AIR FILTERS
Briggs & Stratton, Kawasaki, Kohler and More...
Page 19



WHEEL ASSEMBLIES
Exmark, Scag, Toro and More...
Page 28



BEARING KITS
Exmark, Scag, Toro, and More...
Page 28



DECK WHEELS
Exmark, Scag, Toro, and More...
Page 28



EDGER BLADES
Green Machine, Shindaiwa, Echo and More...
Page 14



TRIMMER LINE
Co-Polymer, Diamond Edge, Inner Core and More...
Page 17



BLADE UPKEEP
Grinders, Replacement Stones, Balancers and More...
Page 31



PROTECTION
Hearing Protection, Safety Glasses, and More...
Page 3 & 29



SPARK PLUGS
Champion, NGK, and More...
Page 18

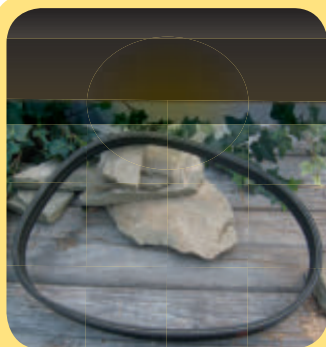

Drive Belt
Scag
 Mow More Catalog #SC02
 Replaces OEM: #48202
 Dual Wheel Drive Belt
 - Double V Belt

Price Each
\$27.55

V-Belts
Page 32



Deck Wheel
Exmark and Toro
 Mow More Catalog #WEX6917
 Replaces Exmark
 OEM #603299 and
 Toro OEM #68-2730

Specs: 5" x 2.75" wheel size
 5/8" ID
 2 3/4" wide
 5" height
 2 1/2" offset hub

Price Each
\$7.00

Price 10+
\$6.75

Price 30+
\$5.90

Wheels
Page 28



Anti-Scalp Roller
 Hardware Kit
Exmark
 Mow More Catalog #WB10007
 Replaces Exmark OEM:
 #603602 bushing
 #98-5961 bolt
 #3290-357 Nut
 #373034 Pivot washer
 #98-5975 Spring washer
Kit contains 1 each of the above

Price Each
\$10.50

Use with WEX6917 Deck Wheel
Bearing Kits
Page 28



Spindle Assembly
Scag
 Mow More Catalog #SH9153
 Replaces Scag OEM:
 46631 and 461663.
 Fits models 1995 to
 present. New style with
 taper roller bearings.
 Cast iron assembly, with
 grease fitting.

Price Each
\$86.99

Spindles and Assemblies
Page 26

No Need To Guess! Simply match the OEM # of the part from your owner's manual to the OEM column in our catalog. If they match - You know you have the right part! Get the right part, the first time. OEM names and part numbers are used for reference only

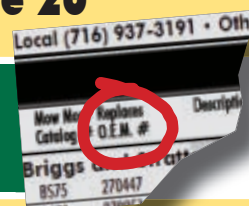

Flat Proof
Exmark, Scag and Toro
 Mow More Catalog #WEX0286
 Replaces OEM#'s Toro
 #633971, Exmark #103-0065
 and Scag #482504. Carlisle
 Reliance Flat Proof Wheel
 Assembly. Painted White.
 Uses WEX9944 Bearing Kit

Price Each
\$99.99

Specs: 13 x 650-6 Flat proof
 6 x 4.50" steel wheel
 7.25" centered hub
 3/4" cups pressed in for tapered roller bearings



Bearing Kit
Exmark, Scag and Toro
 Mow More Catalog #WEX9944
 Bearing kit for own WEX0286,
 WEX0288 and 506DC4-562SM
 wheels. Replaces OEM #
 633585, 633580, 633581,
 254-78 and 254-79

Specs: **Kit Includes**
 (2) Bearings #633585
 (2) Seals #633580
 (2) Spacers #633581
 1 Kit fits 1 Wheel

Price Each
\$13.65

Bearing Kits
Page 28



Oil Filter
Kohler and Others
Mow More Catalog #KO16
 Replaces O.E.M. #1205001 and 1205001S for CH18-25, CV. Kohler short oil filter for 18 and 20 HP engines and 25 HP Command engines. Also fits CV-135.

Specs: 3/4"-16 thread
 3" OD
 2-3/4" height
 32 Micron

Price Each
\$6.15

Price 12+
\$5.35

Price 36+
\$4.55



Oil Filter
Kohler and Others
Mow More Catalog #KO09
 Replaces Kohler OEM# 5205002, 491056. Kohler oil filter for 14, 16, 18, 20 & 26HP. Magnum engines. Also fits CH11-15, CV11-22, M18-M20, MV16-20 & K582. Also fits B & S 491056, Vanguards & twin cylinder engines, Case C26191, Gravely 042366, John Deere AM101207(w/Kohler engine), Toro, NN10147, Woods 70939.

Specs: 3/4"-16 thread
 3" OD
 3-7/16" height
 25.5-27 Micron

Price Each
\$4.75

Price 12+
\$4.20

Price 36+
\$3.50



Lubricant
Mo-Deck
Mow More Catalog #MD9982
 • Prevent clipping buildup
 • Prevents clogging
 Spray on underside of mower deck. Use on grass collection systems and catchers. Use on reel mowers too!

Specs: 11 oz can

Price Each
\$7.50

Price 12+
\$6.95

Price 36+
\$6.40

Lubricants
Page 30



Starter Rope
String Trimmer
Small 2 cycle
Mow More Catalog #SR-3
 Red braided premium starter rope. Heavy Duty. Made in the U.S.A. High quality with low stretch core stiffer, more abrasion resistant. 200' coil. Other sizes available.

Specs: #3-1/2-3/32" Size
 200' Roll
 3/32" Diameter

Price Each
\$16.25

Starter Rope
Page 30

Call for your complete catalog with 1000's of parts inside!

1-800-866-9667 or **www.mowmore.com**



MOW MORE
 LANDSCAPE SUPPLIES, INC.



Idler Pulley
Exmark
Mow More Catalog #EXP9864
 Replaces Exmark OEM: 1-633109 idler pulley fits 52", 60" and 72" deck belts on Lazer-Z units.

Specs: 5/8" ID
 6 3/4" OD
 1-3/16" height

Price Each
\$18.00

Pulleys
Page 26



Idler Pulley
Scag
Mow More Catalog #SCP269
 Replaces Scag OEM: 48269 and 482416. idler fits 40" and 48" decks.

Specs: 3/8" ID
 5 7/8" OD
 1-1/4" height

Price Each
\$14.99

Spindles and Assemblies
Page 26



P.O. Box 342
Lancaster, New York 14086

AD CODE LLMC102E

Attention: Landscape Maintenance
Supply Purchaser

**FREE
SHIPPING!**

on orders of \$250 or more

Excluding oil and grinders

\$25 MINIMUM ORDER

**FAST
FRIENDLY
SERVICE**

www.mowmore.com

1-800-866-9667

**EASY
ORDERING**

1-800-866-9667

www.mowmore.com

**LOOK
INSIDE**

**1000's of
REPLACEMENT PARTS**

