

## A cost-saving way to control fire ants in your landscapes

by Bill Cobb  
and Pat Cobb, Ph.D.

■ The cost of controlling red imported fire ants (RIFAs) can be decreased by using a program similar to the one used at the Colonnade in Birmingham, Ala.

RIFAs are among the most expensive landscape pests to control in the South. Although damage to turf is minimal, fire ants usually build mounds that detract from a landscape's appearance. Mounds are also a reminder that their occupants can inflict painful stings on visitors who disturb them.

Usually, a whole property is scouted regularly and visible mounds are treated with a contact insecticide. This takes time that could be spent on other jobs. Also, colonies that are still small and do not project above the turf are usually overlooked. This results in additional mound treatment throughout the season.

The following study represents an attempt to minimize costs (including labor) while maximizing RIFA control in a commercial landscape.

It is based on the fact that RIFA winged reproductive females and males fly, mate and new colonies are established during warmer months, primarily in the spring. Mated queens can fly several miles if assisted by a tail wind. However, they do not always move that far.

**Background**—The Colonnade is a 106-acre business complex encompassing 54 landscaped acres. The landscape is man-

aged by professional horticulturists. Red imported fire ant control before 1992 consisted of mound treatment only, with acephate (Orthene TT&O). One person needed at least one working day weekly to treat mounds.

The Colonnade grounds and adjacent unmanaged land was scouted in June 1992 to map areas most heavily infested with RIFA. Six highly visible acres that were the most infested were chosen for the study.

It was also an area that, based on previous records, labor and insecticide costs for RIFA control could be calculated.

Three perimeter plots were selected for treatment and three were left untreated. Plots ranged from 2,000 to 6,000 sq. ft. Strips 30 feet wide were treated only in 1992 in adjacent unmanaged areas from which RIFA were believed to migrate into the landscape.

**The process**—In 1992, Affirm fire ant bait (avermectin) was applied to treatment plots and strips with a Solo backpack mist blower equipped with a converter for applying granules. In 1993, Award fire ant bait (fenoxycarb) was applied similarly.

Both baits were applied at 1 lb./acre. Ants were observed picking up bait particles in the treated plots and moving from outside areas into treated areas to collect bait.

Both baits disrupt colony reproductive potential. Worker ants depend on immature stages to digest solids into liquids, the only form of food on which they can feed. Once "immatures" become adults, they can no longer digest solids into liquids and are thereafter themselves dependent on other immatures for digesting solid food. Immature "digesters" feed liquids into workers; workers subsequently feed liquid into each other and into the queen.

Visible mounds in bait-treated areas were treated with a contact insecticide (acephate as Orthene TT&O) within five days after bait applications. This was done to eliminate stinging worker ants quickly rather than waiting six to eight weeks for them to die. Applications were made in June 1992 and August 1993.

Treated plots with the six-acre area totaled 16,000 sq. ft. Not all RIFAs were eliminated, but they were removed from critical locations (treated test plots and surrounding areas). In fact, six acres of control was achieved by treating perimeter areas only. Control costs for the six acres are summarized in Table 1.

**What we learned**—We learned three important lessons about RIFA control from this experiment:

- 1) RIFAs could be mapped. The maps



TABLE 1

Year	Insecticide \$\$	Labor \$\$	TOTAL
1991	\$129.50 (10 lb.)	\$85.00	\$214.50
1992	\$77.70	\$51.00	\$128.70
1993	\$12.95 (2 lb.)	\$8.50	\$21.45

—Source: Dr. Cobb

continued on page 28



Ants were observed picking up bait particles in the treated plots and moving from outside areas into treated areas to collect bait.

represented areas of highest concentration, which included surrounding unmanaged sites from which migration probably occurred. In this case, the landscaped areas were also among the most highly visible parts of the property.

**2) Perimeter treatments were adequate.** Total property treatment, or even treating the six-acre area, was not necessary for acceptable control (based on number of visible mounds).

Baits controlled colonies, including young, not-yet-visible colonies. This eliminated the need for continuous mound treatments throughout the season.

The contact insecticide applied to visible mounds after bait application controlled workers quickly. RIFA workers already present are excellent predators on new queens that fly into an area. Perhaps by leaving a few colonies in less visible areas, new queens were controlled.

**3) Monitoring, mapping and perimeter treatment reduces control costs.**

RIFA control is insecticide-dependent because of the lack of naturally-occurring predators and pathogens. Amounts of insecticide applied were reduced even more with perimeter treatments. Labor costs were reduced because—even though weekly scouting continued—the need for weekly mound treatments was eliminated.

**The future**—Excessive rainfall in 1994 resulted in RIFAs getting a slow start. Fire ant colonies increased dramatically in many areas of the South during late summer and fall. However, only minimum treatment was done at the Colonnade because of the few colonies throughout the season. The 1995 program will be determined after the property is again monitored, mapped and “acceptable” (threshold) levels of RIFA colonies are determined.

—Bill Cobb is operations manager for Environmental Design Group, Birmingham, Ala. Dr. Cobb is professor and extension entomologist at Auburn University, Ala.

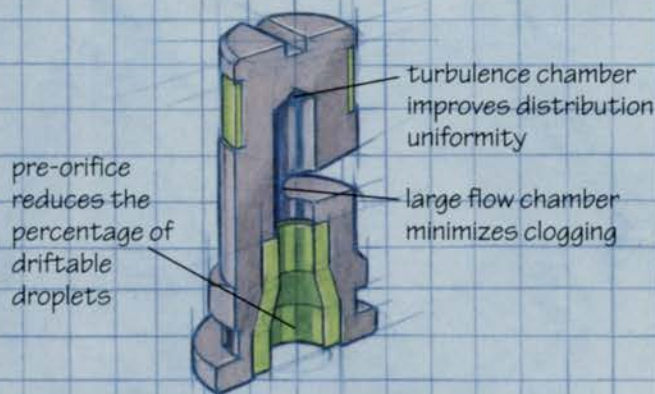

# CAUSE

# EFFECT

You've invested in chemicals, and you want the most out of that investment. But you need to protect your turf and sensitive florals, too. Thanks to a special turbulence chamber and pre-orifice in our Turbo FloodJet® tip, you no longer have to sacrifice effective coverage for drift control – or vice versa. The Turbo FloodJet tip. There's no better way to spray.

**Free Drift Management Tool** Get a specialized slide rule that helps applicators choose the right tip to manage drift for each spray situation – free! Just write to: Drift Tip Selector, Spraying Systems Co., P.O. Box 7900, Wheaton, IL 60189-7900.

 **Spraying Systems Co.**  
P.O. Box 7900, Wheaton, IL 60189-7900

**TeeJet**  
The Drift Control Tip