

LM REPORTS

New skid-steer loaders can pay for themselves in heavy-duty workloads

Versatility a key to overall landscaping effectiveness of these machines.

■ It's no secret why skid-steer loaders are popular in the golf and, especially, landscape industries. It's their versatility. Besides being excellent loaders that can fit into relatively small places where bigger equipment can't, here are some other uses for the machines, if you've got the right attachments:

- stump grinder
- tiller
- snowblower
- landscape rake
- pallet fork
- box scraper
- trencher
- rock-picker
- auger
- trencher
- scarifier
- backhoe

The skid-steer loaders listed below come in every size from small 19 hp engine-driven units with lifting capacities beginning at 750 pounds to the big heavy-duty machines with engines that deliver upwards of 60 hp and lifting capacities over one ton.

A good variety of attachments are avail-



Bobcat with Harley rake attachment

able, many of which are made by the original equipment manufacturers listed below. But there are more, including these:

Glenmac/Harley makes a line of attachments, including its Model S-6 Power Box Rake that can windrow thrown material to the left or right of the rake. Bi-angular construction permits an operator to angle the single roller and twin barrier bar up to



Thomas loader with Rock Hound attachment



JCB's most popular skid-steer

20 degrees left or right of center.

DuAl Manufacturing has both a skid digger (the economical Model 720 digging attachment) and three different models of backhoes (Models 1015, 1025, 1035), along with a line of trenchers. The skid digger can go 72 inches deep with 185-degree bucket rotation.

more on next page

SKID-STEER LOADER SPECIFICATIONS

Model	Dumping Height	Dump Reach	Forward Speed	Lift Capacity	Breakout Force	Tipping Load	Engine Size
Bobcat 753	109.1"	n/a	n/a	1,300 lbs.	n/a	2,600 lbs.	40 hp
Bobcat 763	114.5"	n/a	n/a	1,500 lbs.	n/a	3,000 lbs.	46 hp
Bobcat 773	115"	n/a	n/a	1,700 lbs.	n/a	3,800 lbs.	46 hp
Bobcat 853	119.6"	n/a	n/a	1,700 lbs.	n/a	n/a	n/a
Case 480FLL	101"	27"	21.9 mph	4,572 lbs.	5,185 lbs.	n/a	69 hp
Deere 3375	74.8"	21"	5.8 mph	750 lbs.	1,400 lbs.	n/a	19 hp
Deere 4475	87.9"	20.8"	6.5 mph	1,450 lbs.	2,600 lbs.	n/a	32 hp
Deere 6675	90.4"	28"	7.3 mph	2,000 lbs.	3,712 lbs.	n/a	45 hp
Deere 7775	90.4"	28"	7.4 mph	2,000 lbs.	3,712 lbs.	n/a	52 hp
Ford-NH 464, 465	87.8"	24"	6.6 mph	1,450 lbs.	3,405 lbs.	2,760 lbs.	30 hp
Ford-NH 565	90"	28"	7.1 mph	2,100 lbs.	3,712 lbs.	3,370 lbs.	40 hp
Ford-NH 665	90"	28"	7.1 mph	2,100 lbs.	3,712 lbs.	3,410 lbs.	50 hp
JCB 150	89"	27"	11 km/hr.	3,570 lbs.	1,985 lbs.	1,000 kg.	43 hp
JCB 165	88"	26"	11 km/hr	3,570 lbs.	3,085 lbs.	1,300 kg.	43 hp
Mustang 920	84.5"	19.3"	4.5 mph	850 lbs.	1,800 lbs.	1,700 lbs.	19 hp
Mustang 930A	86.5"	17.5"	5.7 mph	1,000 lbs.	1,975 lbs.	2,000 lbs.	28 hp
Mustang 940	88.5"	21.3"	6.4 mph	1,350 lbs.	4,100 lbs.	2,700 lbs.	38 hp
Mustang 960	92.7"	27"	6.8 mph	1,700 lbs.	5,050 lbs.	3,400 lbs.	57.5 hp
Thomas T-835	69"	14.5"	5.4 mph	800 lbs.	2,200 lbs.	1,800 lbs.	19.8 hp
Thomas T-103	87.8"	24"	5.4 mph	1,000 lbs.	3,250 lbs.	n/a	31.4 hp
Thomas T-133	88.3"	24.3"	6.2 mph	1,300 lbs.	3,260 lbs.	n/a	43 hp
Thomas T-173HL	106.8"	18.8"	7.3 mph	1,700 lbs.	n/a	3,400 lbs.	52 hp
Thomas 203HD	94.2"	29.2"	7.3 mph	2,050 lbs.	5,100 lbs.	4,100 lbs.	52 hp
Thomas-233HD	91"	25.3"	7.7 mph	2,300 lbs.	4,860 lbs.	n/a	62 hp

n/a = not available at presstime

Source: LM mall/phone survey, October 1994



Mustang skid-steer loader in action

To obtain more information, use our easy Reader Service Card and circle the following numbers. For:

- BobcatCircle No. 250**
- CaseCircle No. 251**
- John DeereCircle No. 252**
- Ford-New Holland .Circle No. 253**
- JCBCircle No. 254**
- MustangCircle No. 255**
- ThomasCircle No. 256**
- Glenmac/Harley .Circle No. 257**
- DuAl Mfg.Circle No. 258**

—Jerry Roche



John Deere units carry up to 2000 pounds, depending on model



Thomas's Swinger skid steer



Case's 1838 has a rated operating load of 1300 pounds



Ford-New Holland skid-steers are available with 30- to 50-hp engines

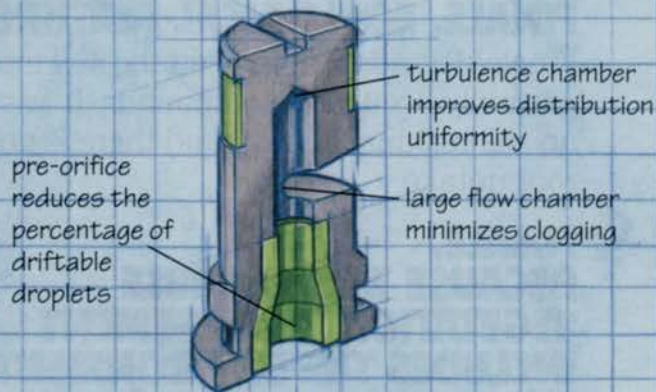

CAUSE

EFFECT

You've invested in chemicals, and you want the most out of that investment. But you need to protect your turf and sensitive florals, too. Thanks to a special turbulence chamber and pre-orifice in our Turbo FloodJet® tip, you no longer have to sacrifice effective coverage for drift control – or vice versa. The Turbo FloodJet tip. There's no better way to spray.

Free Drift Management Tool Get a specialized slide rule that helps applicators choose the right tip to manage drift for each spray situation – free! Just write to: Drift Tip Selector, Spraying Systems Co., P.O. Box 7900, Wheaton, IL 60189-7900.

 **Spraying Systems Co.**
P.O. Box 7900, Wheaton, IL 60189-7900

TeeJet
The Drift Control Tip

Circle No. 123 on Reader Inquiry Card