

PRODUCTS

Low volume rig from Perma-Green

Perma-Green Supreme of Merrillville, Ind. has introduced the GL3001, a low-volume spray rig.

A production capacity of 300,000 square feet per fill-up enables your operator to complete every spray job—large or small—in record time, Perma Green claims.

Twenty-six cubic feet of bagged products, extra chemicals and equipment are kept secure, dry and out of sight in the locking hatchback com-



partment. A gas spring lifts and holds the latch, and built-in brackets secure the spreaders.

Circle No. 190 on Reader Inquiry Card

Four 'heavyweights' for lawn and garden

Agri-Fab has four new products for lawn and garden built to last.

The Model 41-0166 plug-type lawn



aerator connects to tractors and riding mowers with a simple pin hitch.

The Model 41-0184 utility cart has a 17-cubic foot capacity with manual

lift for dumping the big hauling jobs.

The Model 41-0187 broadcast spreader (shown here) holds up to 160 pounds of granulated fertilizers, seed, sand or ice melters.

And the Model 41-0188 5 hp lawn vacuum and 10 cubic foot utility cart hold up to 32 cubic feet of clippings and leaves.

Circle No. 191 on Reader Inquiry Card

Blue River shows rear-mounted blades

Rear-mounted blades from Blue River Equipment ready any tractor to level, scrape, fill, grade, cast, or plow snow.

These blades can be mounted on any standard three-point hitch and come in four- to eight-foot widths. They offer full rotation for a wide range of blade angles. Some models may be offset 12 inches to either side or tilted 15 degrees for ditching.

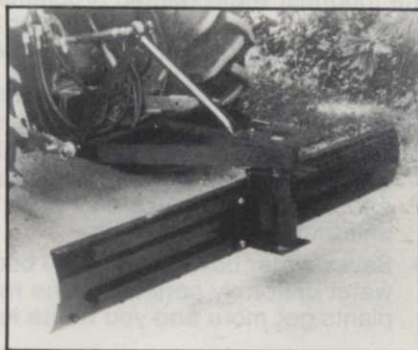

Circle No. 192 on Reader Inquiry Card



ROCKHOUND TEACHES THE ABC'S OF GROUND PREPARATION

A SERIES ROCKHOUND



Dumping



Skid Steer Mount

(Hydraulic)



3 Point Mount

B SERIES ROCKHOUND



Open bottom—PTO Drive. Rocks are raked to a convenient windrow for later pickup.



COST EFFECTIVE ROCKHOUNDS

Rake and collect rocks and surface debris, leaving the soil in a fluffy, level, seed-bed quality condition.

It does not cost to own a Rockhound . . . IT PAYS!

See us at the Landscape Expo in Valley Forge

1-800-426-5615

KEM ENTERPRISES, INC.

2309-A So. Tacoma Way, Tacoma, WA 98409

Circle No. 134 on Reader Inquiry Card

Excel introduces new Hustler Mower

Excel Industries' new Hustler 251 is a dual hydrostatic 18-hp, 51-inch utility-sized mower with twin-lever steering, true zero-degree turning radius, forward-deck design, rear discharge, and vacuum cutting action. An optional Bac-pac grass catcher fits between the mower's rear wheels. Hustler offers a full two-year limited warranty on the 251 model.



Circle No. 193 on Reader Inquiry Card

10 reasons why you should ask for a Continental R-Series engine

High performance, long life design — that's what the Continental R-Series liquid-cooled engines from Teledyne Total Power can offer you.

Take a look at the counter-weighted spheroidal cast iron crankshaft with five main bearings and forged steel connecting rods... right down to the cast iron cylinder block and crankcase, you can depend on the quality to keep up with your

equipment.

Ask for Continental R-Series engines from Teledyne Total Power, with over 5,000 distributors and service centers in over 90 countries ready to serve you. Send for your free "Reasons Why" brochure today: Teledyne Total Power, P.O. Box 181160, Memphis, TN 38181-1160, 901/365-3600, Telex: 462-1058 (ITT)

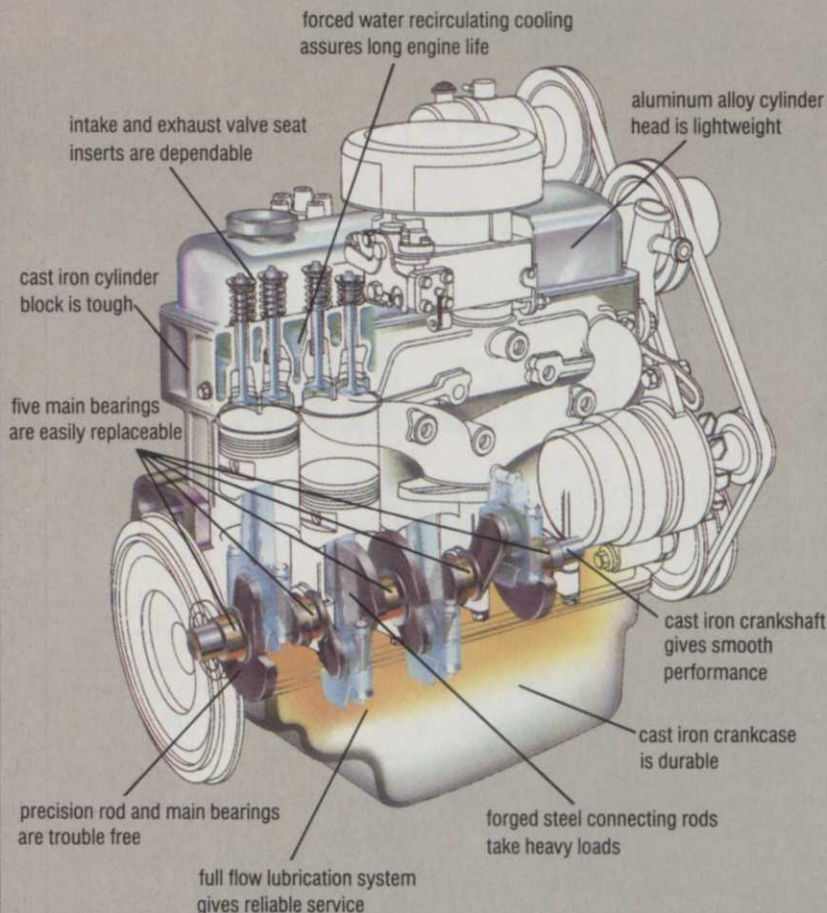

**TELEDYNE
TOTAL POWER**
3409 Democrat Road • Memphis, TN 38118

R-11/14

Circle No. 158 on Reader Inquiry Card

Fiberglass rocks hide aerator floats

Barebo introduces Otter-Rock, a fiberglass accessory designed to simulate rocks, which covers the aerator floats.

The cover gives the impression that the water spray sculpture is natural as it shoots from the aerator unit. An Otter-Rock holds up to six Fountain-Glo lights and will retrofit all aerators up to five hp manufactured



by Barebo.

Aerators control algae buildup and aquatic odors by circulating oxygen back into the water.

Circle No. 194 on Reader Inquiry Card

New Promark lift rotates full circle

The new Promark trailer-mounted aerial lift is powered by an 18-hp twin-cylinder engine that can be started at the bucket.

Rotation is a continuous 360 degrees, and the articulated arms pro-



vide more maneuverability than telescopic lifts. Controls at the base and in the bucket can be feathered to give variable speed operation. The lift is lightweight, stabilized, and easy to tow, says Promark.

Circle No. 195 on Reader Inquiry Card

Oftanol registered for crane fly larvae

Oftanol 2 insecticide, a liquid organophosphate insecticide developed by Mobay Chemical Corp. for insects in turf, has received EPA registration for use against crane fly larvae.

A native of northern Europe, the crane fly is now a major insect problem in Washington and Oregon, and is moving south.



Tests conducted by Mobay have proved that one application of Oftanol 2 provides effective control of crane fly larvae at a rate of one gallon per acre.

Circle No. 196 on Reader Inquiry Card

Trailer allows dual purpose

Long/Run Trailers introduces its ATV-Special, a trailer designed to transport a three- or four-wheeler, and/or to be pulled off road by the ATV. It features a tilt bed, removable sides, and a two position tongue for level towing on- or off-road. Long/



Run says it's a street legal trailer with semi-flotation tires, lights, and safety chain.

Circle No. 197 on Reader Inquiry Card

Hydraulic attachment fits tractor rear

The Hydracutter is the newest hydraulically-powered attachment offered by Ingersoll equipment.

The Hydracutter, a 48-inch



brushcutter, is designed for use behind the 14, 16 and 18 hp Ingersoll HydriV garden tractors.

The cutter has numerous features, among them:

Pivoting mower blades swing back to prevent damage if an obstruction is hit

-Trailing semi-pneumatic



A GREAT TRAILER for TURF MANAGEMENT!



There is a Capacity to Fill Your Needs from 1-Ton to 5-Ton

Steel structured for maximum life and minimum maintenance. Wells Cargo trailers are an easy, economical, efficient way to haul nursery stock, fertilizer, seed, sprayers, implements, mowers... everything your job requires.

We have manufacturing sales & service facilities in IN, GA, TX, & UT and a national network of dealers to serve you.

For FREE literature call TOLL FREE 1-800-348-7553 or write

Wells Cargo, Inc.
P.O. Box 728-595
Elkhart, IN 46515
(219) 264-9661

Circle No. 166 on Reader Inquiry Card

The Growing Choice

Reinco Hydrograssers and Power Mulchers offer you the dependability you need because they are designed with the operator in mind. Our Hydrograssers range in capacity from 800 to 3500 gallons and feature easier to maintain "Hydro-Jet" agitation. Reinco Power Mulchers utilize time proven straight through drive while the M80C offers as standard a variable speed automated bale feed system.

Reinco has been growing for over a quarter century. Why not make us your next growing choice?

See us at:
LICA in Cincinnati,
February 9-12
ALCM in Boxborough,
February 12 & 13
IECA in Dallas,
February 27 & 28
Landscape Expo in Valley Forge,
March 5-7

Call Toll Free (800) 526-7687

Reinco

P.O. Box 512 • Plainfield, N.J. 07061-0512 • (201) 755-0921

Circle No. 153 on Reader Inquiry Card

Slash Costs of Tree Anchoring!

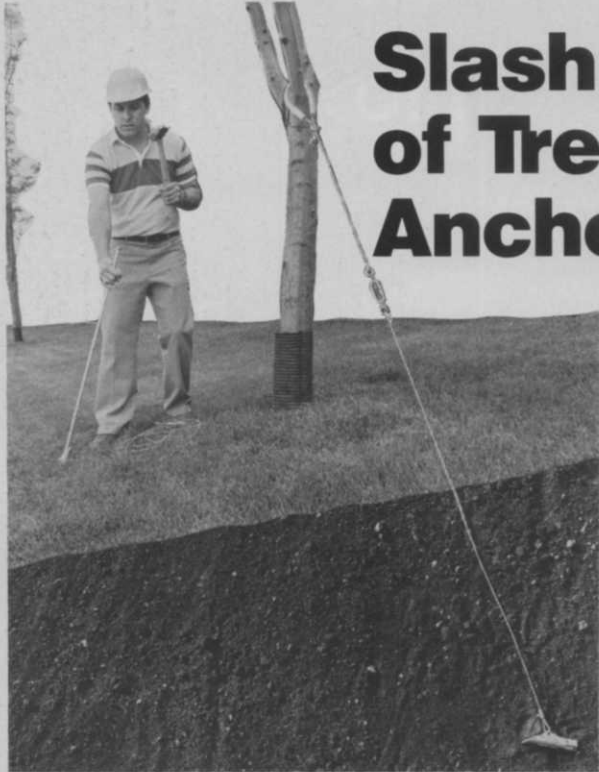

New Duckbill Total System Tree Anchor Installed in Seconds by One Man

The Duckbill Total System Tree Anchor, a completely pre-assembled tree support for trees up to 6 inches in diameter, is available in two models. Model 40, which holds 300 lbs. in normal soil and anchors trees up to 3 inches in diameter, consists of the anchor with 12 feet of galvanized steel cable attached, a tree collar and a 1/16 inch cable clamp. Model 68, which holds 1100 lbs. in normal soil and anchors trees up to 6 inches in diameter consists of the anchor with 13 feet of galvanized steel cable attached, a tree collar and a 1/8 inch cable clamp. Both models are available 3 in a kit or in bulk. A kit of three anchors one tree.

Because it is pre-assembled, the Total System Duckbill Tree Anchor can be installed in seconds by untrained labor. Several trees can be anchored in the time it takes to anchor one tree by conventional methods.



Duckbill is driven into the ground with a drive rod and heavy hammer. An upward pull on the cable rotates the anchor into load lock position, like a toggle bolt in undisturbed earth.

Safe! Strong! Permanent!

Duckbill Anchors are available in different models with holding capacities from 300 to 20,000 lbs. They are the safest anchor you can use because no rigid rods are left above ground to injure people or damage motorized equipment. Once in the ground, Duckbill **stays** in the ground. When anchoring is no longer needed, simply cut cables at ground level, leaving no sign anchors were used. For complete information and your nearest supplier call or write today. Foresight Products Inc., 10780 Irma Drive, Unit 22, Northglenn, Colorado 80233. Phone 1-800-325-5360 or (303) 457-0222 in Colorado.

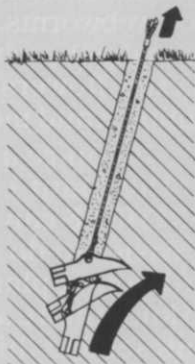

FORESIGHT[®]
PRODUCTS INC.

Circle No. 127 on Reader Inquiry Card

gauge wheels permit easy backing and maneuvering

-Built-in, pre-loaded belt tensioning system.

Circle No. 198 on Reader Inquiry Card

Herbicide controls brush problems

Spike DF, marketed by Elanco Products, controls brush and weeds which choke fence rows and ditch banks. Spike DF is a dry, flowable herbicide which mixes easily with water for spraying areas where brush is a problem.

Spike can be applied at any time of the year, except when the ground is frozen. One application controls mul-



tiflora rose, briars and a variety of woody and herbaceous plants. Livestock can graze in areas where Spike is used, according to label directions.

Sprayers and spreaders for applying Spike are available free from Elanco Products through a promotional program directed toward end users and dealers. Spike is also available in pellet form in a dispensable container.

Circle No. 203 on Reader Inquiry Card

Wide-boom spreader cuts fertilizer costs

The Airjet pneumatic fertilizer spreader is said to improve spreading efficiency and cut costs by almost eliminating frequent boom-instability problems. The spreader, which comes from Britain, boasts boom widths of 53, 60 and 66 feet.

The manufacturer, along with Britain's National Institute of Agricultural Engineering, developed an innovative boom-suspension system which gives the spreader its superior performance. The boom remains parallel to the ground, even when working on slopes, and the suspension system suppresses the bounce, sway and yaw movements which cause erratic spreading. Also, it protects the boom structure against potentially damaging vibrations and shock loads transmitted through the tractor mounting.

The spreader has a 286-gallon capacity hooper which holds more than a ton of granular fertilizer. The machine also spreads microgranular chemicals and seeds.



Circle No. 204 on Reader Inquiry Card

and four-gallon polyethylene tank, and the pull-behind applicator has roller widths ranging from 36 to 48 inches with a 12-gallon chemical tank.



The pull behind attaches to any lawn tractor or three-wheel vehicle.

The direct-lawn applicators are designed for use at home, business or institutions.

Circle No. 205 on Reader Inquiry Card

Core cultivator has new re-styled engine

The newest model of the Ryan Greensaire II core cultivator features a streamlined 8-hp Kohler engine.

The engine has a five-quart gas tank for 25 percent more fuel capacity than previous models. The oil dipstick is on top of the engine for easier access. And, instead of a separate stop switch, there is a "stop" position on the throttle.

The self-propelled Greensaire II can cover up to 6,900 sq. feet per hour with a 24-inch swath and two-inch coring pattern that removes 36 cores per square foot.



Circle No. 200 on Reader Service Card

Direct lawn applicator eliminates overspray

A unique roller arrangement in Danville Industries' new express direct lawn applicators puts chemicals only where you want them. Liquid fertilizer or weed killer can be spread evenly and directly without overspray possibly harming nearby gardens or shrubs.

Two express models are available. The hand model has a 30-inch roller

MT3000™ SPRAYER CONTROL



Only
\$895.00

The MT3000 pays for itself many times over by eliminating costly over and under applying of herbicides, pesticides and liquid fertilizer. Simply select your desired rate of chemical application and the MT3000 will maintain that rate regardless of speed or boom control change. Take the guess work and waste from your spray program and watch the savings go in your pocket.

Also from Micro-Trak:



FLOWTRAK™
SPRAYER MONITOR

Provides direct measurement of speed, application rate, total liquid applied, area worked and distance.

Mfd. in U.S.A. by:



MICRO-TRAK
SYSTEMS, INC.
An Electronics Company

FOR COMPLETE INFORMATION
CALL TOLL-FREE

1-800-328-9613

(Collect in MN (507) 257-3600)

Circle No. 140 on Reader Inquiry Card

SPRING
SPECIAL!

\$4,495
F.O.B. FACTORY



SANDANCER UTILITY VEHICLE

- Model 4: 3 wheels
- 1500 lb. payload
- 5 foot tilt bed
- Strongest utility vehicle built
- 7 major automotive components

SPECIAL \$4,495 PRICE FOR 3 MONTHS ONLY!

Orders must be received by April 30, 1986.

Contact your local distributor or call direct.



TURF VAC CORPORATION

P.O. Box 90129
Long Beach, CA 90809
(213) 426-9376

Circle No. 162 on Reader Inquiry Card