

Under Cover

The Use of Winter Turf Covers is More Personal than Universal

By D. DOUGLAS GRAHAM
Golf Course Management Magazine

Snow is a near-perfect insulator, ideal for protecting cultivated grass. But in this age of climatic changes and possible global warming, snow is fast becoming a vanishing resource. Not so long ago, the arrival and departure of winter snow and ice was a predictable phenomenon. Today golf course superintendents from Helena, Mont., to Helsinki, Finland, can no longer depend on Old Man Winter to dump a natural turf cover on their greens. These days one must rely on technology and ingenuity to do what nature apparently can no longer do with regularity.

Artificial turf covers provide a rational alternative to snow and ice. Covers are increasingly deployed on golf course greens the world over, but no single insulator will work for every winter scenario. Microclimate is everything, the experts say, and what works in Helena may fall flat in Helsinki.

"The first thing to consider is where you are," says Julie Dionne of Laval University in Quebec City, Canada. "No one cover will work in all situations. Quebec City gets lots of snow, much more than Montreal. What you use and how you use it will differ accordingly to each situation."

A Telling Test

In the early 1990s, Laval University conducted a series of experiments to gauge the effectiveness of different turf covers in limiting winter damage to *Poa annua* golf greens. The two sites were Montreal Country Club in St. Lambert and a testing facility at the university. One unprotected control plot was tested against seven covered with the following materials: a

permeable Evergreen cover, an impermeable Evergreen cover, a mat composed of curled wood shavings covered with an impermeable Evergreen cover; a permeable Evergreen overlaid with 15 centimeters of hay and a top layer of impermeable Evergreen, a wooden shelter shrouded with a layer of impermeable Evergreen to allow for a 5-centimeter air space, a light felt material overlaid with impermeable polyethylene and a thick felt overlaid with impermeable polyethylene.

The covers were in place by the winter of 1993-94 and removed in April 1994. The results of the test were conclusive. First of all, the notion that local weather conditions determine the use and effectiveness of winter turf covers was confirmed in spades. The snowfall in Quebec City was far greater than in Montreal. The snow insulated the Laval test sites and stabilized temperatures throughout the season. But winter damage occurred nevertheless. Snow molds were present on the plants because of the warming conditions created by the covers and augmented by the heavy snow.

Conclusion: Under certain conditions, covers may actually open the door to turf disease, illustrating the need for fungicidal treatment before they are installed.

Montreal, meanwhile, experienced very different winter conditions during the testing period. Harsh winds buffeted the course, and a light accumulation of snow was washed away by heavy rains. The covers were all that stood between the test greens and the destructive effects of the season, and, because of this, each one could be evaluated separately.

For instance, the curled wood mat proved to be the most effective insulator, and the *Poa* green underneath it emerged virtually unscathed. The felt covers, both thin and thick, did not fare as well as the curled mat, while the turfgrass covered with only a thin layer of permeable and impermeable material with no insulating layers did the poorest of all. Turf damage due to freezing put the Montreal greens out of commission until May 1995.

But stand-alone permeable and impermeable covers can prove essential to winter turf health. While they provide little by way of insulation, they do fend off desiccation and frost damage. Impermeable covers, when used in combination with other materials, protect against ice and prevent seepage into the other insulators layered beneath them, such as hay and wood mat.

The study uncovered additional data as well. Monitoring the microclimate under the protective covers helped determine the proper time to remove them. This was accomplished by installing thermocouple wires under the covers and periodically recording the results.

Knowing when to install and remove covers is vital. Early implementation can retard the hardening of the soil. Taking the cover off too late may weaken the plants' ability to repair themselves. Once the cover is off, it will be necessary to wean the grass from the microclimate it has become accustomed to. Permeable covers should be used after the winter cover has been removed. This light covering will shield the green from lingering winter effects.

(Continued on Page 23)

We're Right on Par for What You Need!

Applications for All Areas of the Game.

Soil Solutions!

from *Floratine*

CalpHlex-

The Economical, Highly Soluble Calcium Chelate for Managing:

- Calcium Deficiency
- Magnesium Excess
- pH Balance
- Sodium Build-Up

Maxiplex-

The Concentrated Liquid Humic Acid for Better Management of:

- Compaction
- Nutrient Tie-Up
- Leaching
- Hot Spots

Floratine Products Group
129 S Main, Collierville, TN 38017
(901) 853-2898

FLORATINE PRODUCTS

#1 in BioStimulants



JUST FOR THE
HEALTH OF IT!

*ASTRON PLUS *PER "4" MAX PLUS
*KNIFE PLUS *RENAISSANCE

*and other patented hormone
balanced auxiliary nutrient
compounds promoting
improvements in turfgrass:*

- *Root Development
- *Stress Resistance & Recovery
- *Health & Quality

*Decidedly Different in
Design & Performance*

Aqua-Vive

Biological Water Clarifier



- Eliminates Murky Water
- Eliminates Odors
- Controls Algae Bloom
- Removes Surface Scum

PROUD

to be a member



Platinum Tee Club

THANKS

*to our many turfgrass
management friends*

FLORATINE

*Creative Solutions for
Turfgrass Management*



179 So. Main/Collierville, TN 38017
(901) 853-2898

For More Information Call Dan or Rick at 612-934-1205

Superior Tech Products 80 W 78th St, Suite 135 Chanhassen, MN 55317

Under Cover—

(Continued from Page 21)

Turf Covers in the Real World

While winter turf covers may be a practical alternative to snow in some parts of the country, many superintendents don't endorse their use. Installation is labor-intensive, some say, and removing the cover prematurely can actually damage a green. Also, seeded grass can grow into a tarp and come out of the ground in clumps when the cover is removed.

"I've actually seen that happen," says Joe Adams, assistant superintendent at Omaha Country Club in Omaha, Neb., and a member of GCSAA the last eight years. "There are lots of problems with covers, another being the problem you sometimes get with ice storms. When ice accumulates on the covers, it seals off the green. You may have to break it off several times in a single season to oxygenate the grass. The combination of ice and tarp can kill a green."

There are other hazards to turf covers besides premature or incorrect removal. Covers may also create their own greenhouse effect, subjecting the grass to disease pressure even as they protect it for winter desiccation.

"You can't take a cover off quickly without risking the health of the grass," says 21-year veteran John Hoofnagle, CGCS at Valley Country Club in Aurora, Colo. "Removal requires a weaning period. Spring in Colorado can mean warm days, cold nights and frost on the ground the following morning. You can either recover the grass at night, which workwise is no picnic, or you leave the cover on through the spring, creating a microenvironment that may encourage the growth of snow molds and other diseases. Then you have the problem of winter play. We get a lot of that here, and for the players covered greens are unacceptable."

For Adams, Hoofnagle and many others, the best way to protect a green from the ravages of winter is to allow the season to run its course. Mother Nature has her stormy side, but she also takes care of her own. When it's available, snow and ice, with intermittent winter watering, provides more than adequate protection and does so without subjecting the grass to unnatural stress.

Other superintendents augment nature with nature, employing the materials provided by Mother Earth to protect carefully cultivated greens.

Four-year GCSAA member John DeCora, superintendent at Court House & Jail Rock Golf Course in Bridgeport, Neb., covers his greens in the winter with sand.

"The sand is applied in a light coat over the crown. After that, the key is moisture," DeCora says. "Artificial covers really don't work as well as natural ones, and they're also relatively expensive. This is a pretty small course. Four thousand square feet of turf cover is more than adequate to protect it. But the covers would cost us about \$400 to \$500 per green and maybe \$5,000 to cover them all. Another problem: They don't last very long. Inside of four or five years, they're shot and you have to buy more of them."

But for every opponent of winter covers, there are other superintendents who rely on them religiously. Mike Cohrs, the assistant at Buffalo Run Golf Club in Buffalo, Minn., describes artificial winter insulators as "a definite help," and points to the unusually wet winter of 1996 in Minnesota as a prime example.

"There was between ½ to 2 inches of ice on the ground statewide. Lots of places around here had no covers and had plenty of damage as a result," Cohrs recalls. "We routinely cover all of our 19 greens with something called HPI covering. It's made out of synthetic strands all weaved together. We put it down like a very thin carpet and because it's so thin, it allows for oxygen and sunlight penetration.

"We also use Excelsior matting, a plastic matting about ½-inch thick with wooden fibers mixed into it. The wood chips create air pockets that allow the plants to breathe. On problem greens, we use Excelsior in combination with HPI. We have depressions in some areas of the course which, uncovered, would fill up with water and promote freeze damage. Covered or not, problem greens remain problem greens. But the insulators help keep the problems under control."



Golf Course Accessories

- Ball Washers • Detergent
- Mounting Pipes & Bases
- Tee Signs • Spike Brushes
- Hole Cutters • Flag Poles • Flags
- Cups • BunkerPro Rakes™
- Benches • Trash Mates™
- Tee Markers • Practice Greens
- Markers • Whipping Poles
- Course Signage • Divot Mates™
- And More...

*Requested by players.
Preferred by course professionals.
Specified by designers and used
with pride wherever golf is
played.*

Call your Par Aide dealer today
for a FREE CATALOG, or call us
for the dealer nearest you:
612-779-9851

© 1997, Par Aide Products Co., St. Paul, MN.

TEE-TO-GREEN QUALITY FROM JOHN DEERE

2653

Hydraulic reel drive, exceptional climbing ability, and 26-inch cutting units let you mow where others can't.

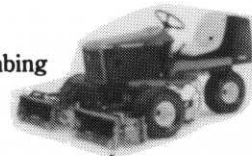

GATOR VEHICLES*

Your best choice for utility hauling with 4- and 6-wheel low-ground-pressure models available.



3215/3235

Both deliver ground-hugging fairway performance with five John Deere-manufactured 22-inch cutting units.

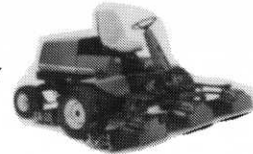

3365

Five 30-inch cutting units combine to deliver a quality cut over wide areas—from fairways to roughs.



1200A

New design features more power, more comfort, more attachments, and less noise.



1800

True utility performance with your choice of sprayer, spreader, and cargo box configurations.

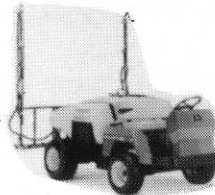

220

This new walk-behind features an operator-presence safety system, new engine, and 11-bladed reel.



2243

Gas and diesel models both feature 18-hp engines and John Deere cutting units, for exceptional quality of cut.

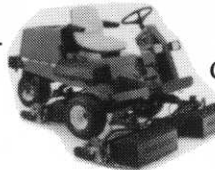

NOTHING RUNS LIKE A DEERE®



Polfus Golf & Turf

12040 Point Douglas Drive S.
Hastings, MN 55033

Call for a Demonstration

Phone: (612) 437-7747 or Fax: (612) 437-3483

Protecting Your Assets

Washing equipment; it's a task that thousands of businesses in Minnesota do every day. Maintaining expensive equipment is a lot easier if the equipment is clean, not to mention that the appearance of our equipment says a lot to our customers about our organization's maintenance philosophy.

What about our environmental philosophy? "A picture is worth a thousand words" strikes very close to home in the golf business. Aesthetic appeal is near the top of the list when it comes to why golfers return to a certain course time and again.

Superintendents and other management personnel can talk 'til they're blue in the face about environmental stewardship. Statistics can be quoted ad nauseum about pesticide application, fertilizer use and the overall care in which chemicals are handled.

However, all it takes is one instance of a golfer or passerby (especially a passerby with an agenda) witnessing what he interprets as environmental callousness. Though unwarranted, we know that much of the public (especially non-

golfers) hold the industry in low esteem environmentally.

How many times have you seen equipment washed-off near surface water? It doesn't take close inspection to see an oil sheen floating down a lateral hazard. It's hard not to notice areas around a maintenance building that are stark in comparison to the adjacent fairway. It just doesn't look good (or smell good) when clippings are left to compost in a haphazard manner in areas that are close to foot traffic.

With all the time that is spent by the golf industry to maintain the beauty and playability of the course itself, it might be a good idea to do something as simple and as inexpensive as installing a curbed or trenched concrete washpad.

Not only will this look good, but it will let the staff know that there is now a *place* to wash equipment, or mix and load, or do routine maintenance. And now you are in control. The risk of accidental discharge or bad publicity has just been dramatically reduced. For one-third the price of a new mower you get twenty years of peace-of-mind.

LEGACY – RELIABLE PRODUCTS FOR GOLF COURSES

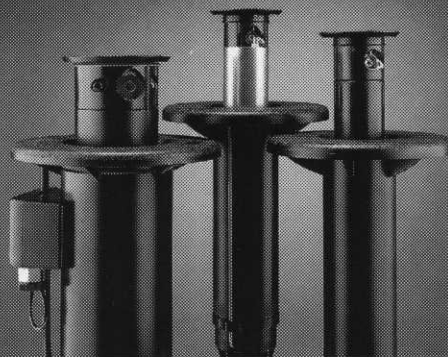

Legacy Golf Rotors

Century – Your Link to Legacy Golf

More golf course professionals like yourself are switching to Legacy irrigation. Your local Century golf representative can show you the advantages of a Legacy system and can offer valuable technical assistance on a new course or retrofit.

CENTURY GOLF PROFESSIONAL - MINNESOTA
Arlan Rust • 608-583-3039

LEGACY GOLF NOW
AVAILABLE AT
CENTURY RAIN AID IN
THESE MAJOR MARKETS

- ALABAMA • DELAWARE
- FLORIDA • GEORGIA
- ILLINOIS • INDIANA
- MARYLAND • MICHIGAN
- MINNESOTA • NEW JERSEY
- NORTH CAROLINA
- PENNSYLVANIA
- SOUTH CAROLINA
- VIRGINIA • WEST VIRGINIA
- WISCONSIN
- ONTARIO, CANADA

Call for a Free Catalog
800-347-4272

www.rainaid.com

CENTURY RAIN AID

No belts. No pulleys. No kidding.

The Jacobsen HR-5111's exclusive Multi-Motor deck design delivers a whole new angle on rotary performance.

Individual hydraulic motors drive each blade for unmatched cutting power, while eliminating time-consuming routine maintenance. This design also enables the blades to rotate in opposite directions for more even clipping dispersal. Team that with our floating-decks, and you've got a cut so clean you'd swear it was done by a reel mower.

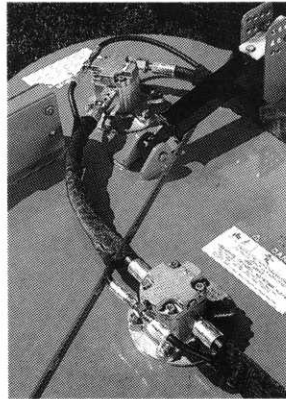

Individual hydraulic motors drive each blade for unmatched cutting power and reduced maintenance.

A full 11' cut and 51 horses of liquid-cooled diesel power let you mow up to 65 acres a day. Plus, agile rear-wheel power steering, a compact design and hydrostatic 4WD allow you to cover ground that other production rotaries simply can't.

For more information about this serious producer, or to see one in action, contact your Jacobsen dealer today.

THE PROFESSIONAL'S CHOICE ON TURF.

JACOBSEN
TEXTRON

Jacobsen Division of Textron Inc.



NORTH STAR TURF, INC.

3080 Centerville Road
St. Paul, MN 55117

(612) 484-8411
(800) 592-9513



1997 MGCSA Championship Results

RUSH CREEK GOLF CLUB

PAR 72

Championship Flight

Tom Meier	76
Bruce Leland	77
Chris Manor	77
Shane Eastman	78
Tom Notch	79
Jim Terry	79
Steve Tomaszewski	80
Chuck Egeberg	81
James Kimberly	81
Mike Hilliard	81
John Rice	81
Scot Ender	82
Monte Swift	82
John Nylund	83
Leif Erickson	83
Brad Klein	84
Jerry Webb	84
Steve Busch	84
Duane Slaughter	84
Jay Monson	85
Joe Buege	85
Mike Brower	85
Toby Weibye	85
James Johnson	86
Mike Klatte	87
Dale Parske	88
Jonathan Pulju	88
Larry Vetter	89
James Gardner	89
Martin Terveer	89
Walt Braung	90
Brooks Ellingson	91
Thomas Schmidt	91
Jason Spitzner	91
Mike Nelson	93
Paul Johnson	94
Charlie Miller	101

First Flight (net scores)

LeRoy Wurm (81)	67
Cliff Reynolds (81)	71
Steve Schumacher (87)	71
Tom Stout (82)	71
Greg Hubbard (84)	72
Lance Paulson (83)	72
John Betchwars (85)	72
Chuck Schoenrock (83)	73
Steve Garske (89)	74
Rick Traver (84)	75
Tom Ferniacek (92)	75
Dave Zimmer (95)	76
Chuck Tuthill (86)	76
Doug Mahal (89)	76
Jim Nicol (92)	77
John Ganske (89)	77
Tom Mundy (89)	77
Paul Jones (92)	78
Don Phenow (90)	78
Dale Hiebert (92)	78
Mark Ness (90)	79
Don Egeberg (90)	79
Butch Greeninger (94)	80
Chris Crockett (94)	80
John Olson (98)	80
Joe Dinnebie (94)	82
David Kirscht (92)	83

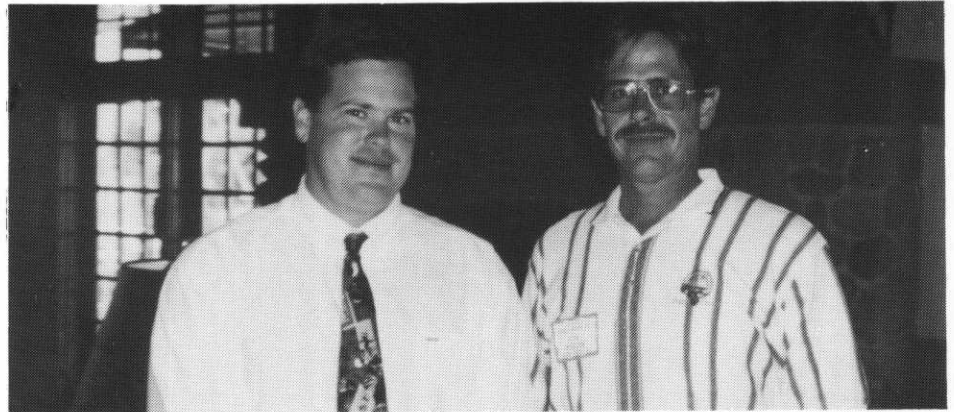

Rush Creek Superintendent Tom Fuller, right, with General Manager Ed Money.

Mike Olson (97)	84
Jeff McDowell (98)	85
George Peterson (101)	85
Eric Sundet (100)	85
Scott Weltzin (95)	85
Keith Flatebo (98)	86

Second Flight (net scores)

Tom Little (91)	68
Marlin Murphy (94)	73
Mike Ligday (95)	74
Bob Fredericks (96)	74
Jon Almquist (94)	74
Bob Adams (95)	75
John Glattly (98)	75
Dale Waleschek (100)	78
Fred Taylor (101)	78
Steve Hamelau (99)	79
Ron Furlong (100)	80
Frank Hoffman (102)	81
Dan Evavold (105)	83
Forrest Tibbetts (106)	83
Shaughn Erickson (108)	83
David Krueger (105)	84
Mark Paffel (119)	85
Jake Jensen (110)	89
Brian Kenny (117)	89
Allen Starke (115)	90

Senior Flight (net scores)

John Monson (81)	69
John Beyer (91)	73
Jerry McCann (85)	74
George Jennrich (99)	80
Gary Rohling (102)	82
Tom Kientzle (100)	85
Joe Check (117)	89
Daryl Scheerhoorn (122)	95
Richard Kolter (107)	98

Callaway Flight (adjusted scores)

Dean Spencer	70
Dean Chaltas	70
Rod Hanson	71
John Quinlan	72

Adam Gable	72
Tim Berquam	72
Kevin Clunis	74
Chuck Molinari	74
Jay Stadler	74
Eric Netz	74
Donnacha O'Connor	74
Enda Murphy	75
Randy Adelsman	75
Troy Carson	75
Bob Atol	75
Edwin Lahr	75
Tom Fuller	77
Jeff Ische	77
Ben Ratzlaff	77
Jason Yonak	77
Ben Sabas	78
Kevin Froemming	78
Tom Lundgren	78
Alex Ellram	80
Tom Fischer	80
Bob Hefta	80

Rush Creek—

(Continued from Front Cover)

shot 81 and netted out to a 68.

Dean Spencer, assistant superintendent at Edinburgh USA, won the Callaway Flight as the numbers worked out to a 70.

Closest-to-the-Pin honors went to Brad Klein, Chris Manor, James Gardner and Tom Meier. Klein, Northern Turf Services, also had the longest drive of the day on number 16.

Next month the superintendents will travel to the Brainerd Lakes area where they will participate in the Stodola Scramble on September 14 at The Preserve in Pequot Lakes. Host Superintendent Mike Bohnenstingl anticipates a great time up north for all participants and their families.

Troubled waters?

Otterbine Aerators

The prescription for troubled breathing, poor circulation, and changing temperatures in ponds and lakes is practical engineering that is esthetically pleasing.

These aerators range in power, circulating from 600,000 to 20 million gallons of water in a

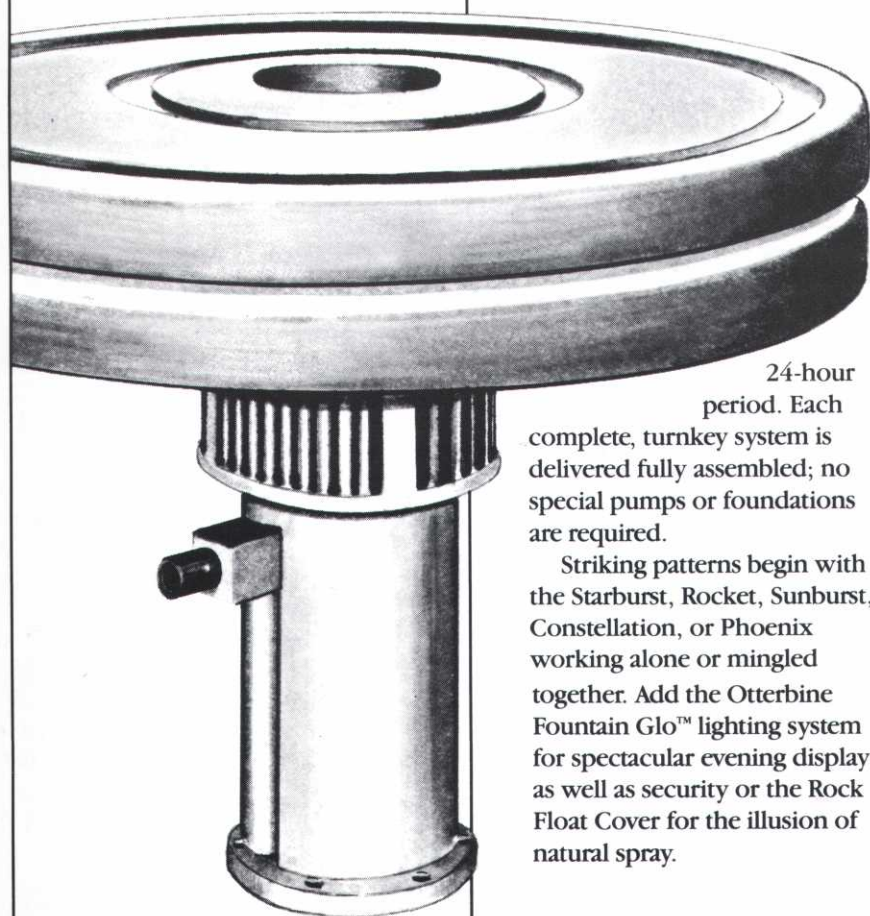

24-hour period. Each complete, turnkey system is delivered fully assembled; no special pumps or foundations are required.

Striking patterns begin with the Starburst, Rocket, Sunburst, Constellation, or Phoenix working alone or mingled together. Add the Otterbine Fountain Glo™ lighting system for spectacular evening display as well as security or the Rock Float Cover for the illusion of natural spray.

Otterbine Aerators meet the water management needs of golf courses, parks, recreational lakes, office developments, and residential condominiums. Call or write for more information:

MTI DISTRIBUTING CO.

14900 21st Avenue North
Plymouth, MN 55447

612-475-2200

1-800-362-3665



MEMBERSHIP REPORT

NEW MEMBERS: JULY 14, 1997

	Class
Lorie Kjergaard Crystal Lake Golf Club 17079 Isleton Ave., Lakeville, MN 55044 W: 612-953-3656	A
Rob St. Sauver The Broadmoor Golf Club 712 Prospect Lake Dr., Colorado Springs, CO 80910 H: 719-473-4862	C
Jeff Dahl Rose Lake Golf Club, Inc. 310½ E. Blue Earth Ave., Fairmont, MN 56031 H: 507-238-5454	C
John L. Poepping Pierz Municipal Golf Course P.O. Box 234, Pierz, MN 56364 H: 320-468-6963	C
Kurt Haugen Hennepin Parks — Glen Lake Golf & Practice Center 14005 40th Ave. No., Plymouth, MN 55447 H: 612-553-2815	C
John Paul Larson The Wilds Golf Club 1987 Christenson Ave., No. 7, West St. Paul, MN 55118 H: 612-552-7107	C
Scott A. Schurman Crystal Lake Golf Course 13421 Cedar Ave., Apple Valley, MN 55124 H: 612-953-4102	C
Todd J. DiBrito Rich Spring 17435 Fairway Circle, Cold Spring, MN 56320 H: 320-685-3571	Student
Matthew W. Kuha Tianna Country Club P.O. Box 297, Walker, MN 56484 H: 218-547-3702	Student
Anders Johansson University of Minnesota R.R.1, Box 58, Ghent, MN 56239 H: 507-532-9745	Student
Robert W. Stern Pebble Creek Golf Course 10050 185th Ave., S.E., Becker, MN 55308 H: 612-263-5030	D
Joe P. Otto The Wilds Golf Club 12531 Portland Ave. S., Burnsville, MN 55337 H: 612-882-7820	D
David C. Swift The Wilds Golf Club 104 Swanson Dr., Sherburn, MN 56171 H: 507-764-3796	D
Don Diederich Crystal Lake Golf Course 679 Orrin St., St. Paul, MN 55102 H: 612-228-9298	D
Jay Monson North Star Turf, Inc. 914 Woodland Circle, Long Prairie, MN 56347 H: 320-732-3696	F

RECLASSIFICATIONS

Duane Stritesky Whitetail Golf Course	B to A
Mike Nelson The Links at Northfork	C to B
Christopher Smith Golf at the Legacy	D to C

*Steve Shumansky,
MGCSA Membership Chairman*

We'd like to say we buried the competition. But that would mean putting an extremely inferior fertilizer in the ground.



Only par ex with IBDU® has the highest WIN percentage.
We have more than Lebanon® and more than Scotts®. Because the higher the Water Insoluble Nitrogen content, the longer your turf will remain green and the less chance there is for burn.



FROM FERTILE MINDS.

Lebanon is a trademark of Lebanon Seaboard Corporation. Scotts is a trademark of O.M. Scotts & Sons Co. © 1996 IMC Agri-Business Inc. All rights reserved.

Precision Turf & Chemicals
7728 Commerce Circle
Greenfield, MN 55373
612-559-5293

Ken Quandt
Territory Manager
West Allis, WI
414-327-3993

Grow With Us™!



New construction or course renovation, contact LESCO for premium performance turf seed varieties and 18-24-12 starter fertilizer with PolyPlus® SCU. To obtain more information on LESCO turf products contact your LESCO Professional Golf Representative or call (800) 321-5325.

LESCO™

LESCO and Grow With Us are trademarks of LESCO, Inc.
PolyPlus is a registered trademark of LESCO, Inc.

1998 ESA Applications Are Now Available

If you've implemented innovative environmental stewardship practices at your facility, consider yourself a candidate for the 1998 Environmental Steward Awards (ESAs).

For the sixth year, the ESAs will be presented to golf course superintendents around the world. Sponsored by Novartis, Rain Bird, Jacobsen Division of Textron and Pursell Technologies Inc., the awards recognize golf course superintendents for their commitment to environmental stewardship efforts on golf courses.

GCSAA will be administering the program in 1998. Applications are available in the August issue of *Golf Course Management* magazine and from each of the participating sponsors. Entries will be due Oct. 31 and will be reviewed by an independent panel of judges. Winners will be announced in late December.

Since 1993, participating sponsors have donated nearly \$100,000 to The GCSAA Foundation, and 150 golf course superintendents have been recognized with these awards.

Entries for the 1997 awards included 63 applications, with 31 superintendents recognized in the national, regional and merit categories. National winners were:

- Private course (tie) — Glenn Smickley, CGCS at Robert Trent Jones Golf Club in Gainesville, Va., and Kerry Satterwhite, CGCS at Rock River Country Club in Rock Falls, Ill.
- Public course — Timothy Kelly, The Village Links of Glen Ellyn in Glen Ellyn, Ill.
- Resort course — Ron Hill, CGCS at Amelia Island Plantation in Amelia Island, Fla.

Golf course superintendents and the facilities receiving national recognition in 1997 are not eligible to apply for the 1998 awards. A three-year moratorium for national ESA winners and the winning facilities has been established to allow other honorees to enter the winner's circle. This decision was made by program sponsors based on feedback received by GCSAA members, previous judging panels and other participants.

ESA recognition opportunities include:

- An introduction of national winners during the Government and Environmental General Session at GCSAA's 69th International Golf Course Conference and Show in Anaheim, Calif.
- Receptions honoring winners before and after the Government and Environmental General Session.
- A personal invitation for each winner's general manager/owner to attend the Government and Environmental General Session and receptions.

- A feature in the February 1998 issue of *Golf Course Management*.

- A donation from sponsors to the GCSAA Foundation in the name of regional and national winners.

- A personalized plaque for regional and national winners.

- A traveling trophy for national winners.

- Regional and local publicity for all winners.

For more information about the Environmental Steward Awards, contact GCSAA's media/public relations department at 800/472-7878, ext. 430 or 608, or e-mail to kfrey@gcsaa.org.

ESA awards are sponsored by:

- Novartis
- RainBird Golf Irrigation
- Jacobsen Division of Textron
- Pursell Technologies Inc.

A Growing Business:

**More seed, service, and
satisfaction for you.**

We're growing to meet your needs for improved turfgrass seed, wildflowers, and erosion control products. All at reasonable prices and just the right kind of services. Call 1-800-545-TURF.

**TWIN
CITY
SEED**
C O M P A N Y

7265 Washington Avenue So.
Edina, MN 55439
Phone: 612-944-7105
Internet: www.twincityseed.com

