

14900 - 21st Ave. No.  
Plymouth, Minnesota 55441  
(612) 475-2200

1-800-362-3665 Minnesota  
1-800-328-3558 Out State

## TURFCO Sod Master

Mete-R-Matic II employs Turfco's original and proven principle of a conveyor, metering gate and revolving, cylindrical brush to drive top dressing down into turf.

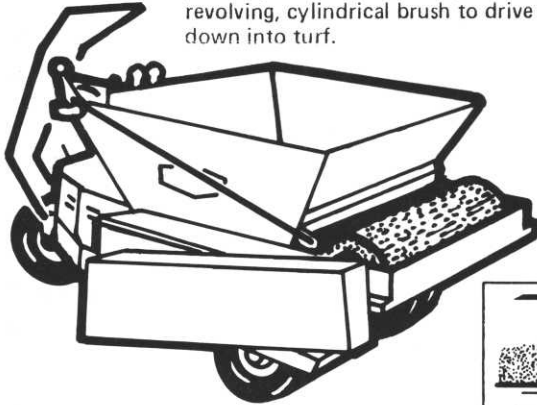

METE-R-MATIC  
SELF-PROPELLED  
TOP-DRESSER

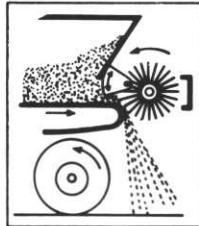

### IDEAL FOR:

golf course greens, tees and fairways; for football and soccer fields; for application of calcined clay on baseball diamonds; for parks and recreation areas; for industrial and commercial grounds; and for sanding icy sidewalks and driveways.

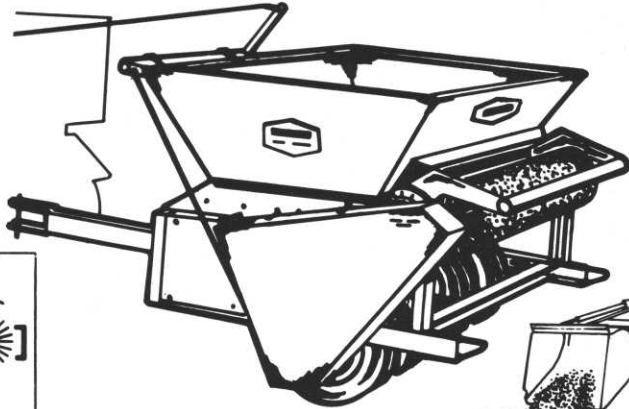

METE-R-MATIC II  
TOP-DRESSER

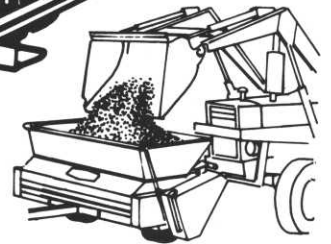

## Olathe



### OLATHE MODEL 65 P.T.O. SWEEPER



- 5 CUBIC YARD HOPPER
- TIMED CHAIN DRIVEN REELS
- HEAVY DUTY GEAR BOX AND P.T.O. SHAFT

MODEL 65 SHOWN WITH OPTIONAL MODEL 87 THATCHER REEL



### OLATHE MODEL 166E TURF SWEEPER

- 5 CUBIC YARD HOPPER
- TWIN CYLINDER 18 H.P. BRIGGS & STRATTON ENGINE
- ELECTRIC START • TIMED BELT DRIVEN REELS
- REMOTE CONTROLS FROM OPERATORS SEAT INCLUDE:  
HYDRAULIC HOPPER DUMP  
HYDRAULIC REEL ADJUSTMENT



**UP TO 40% DISCOUNT ON SELECTED TORO PARTS  
SALE ENDS APRIL 30, 1986!!**



## MINNESOTA'S GOLFING HERITAGE



## INTERLACHEN COUNTRY CLUB

DOUG MAHAL  
Golf Course Superintendent  
Interlachen Country Club

The first steps in the realization of Interlachen began on November 16, 1909 when fifteen members of the Bryn Mawr Golf Club met in the Kauerhof restaurant to discuss the formation of a new golf club. Their meeting was the result of recent events at Bryn Mawr where real estate developments were encroaching on their playing ground. As one of the fifteen explained, "Every month they built a house somewhere on one of the holes and we had to change the course." After the initial meeting, six of the fifteen remained who felt a new club could and should be established. These men began a long search for the right location offering trees, water and rolling terrain. Eventually, three farms, totaling 146 acres were selected and the six men made up a pool of \$1000 for the option. As history has it, one of the farmers demanded gold as payment for his parcel. Upon arrival at the farmhouse with the gold one evening, one of the six found the farmer unwilling to keep the gold in his home for fear of burglary. So, with shotgun in hand, the member-courier stayed up all night in the farmhouse until the banks opened up the next morning. Additions of 20 and 14 acres were later purchased and on December 31, 1909, the club was incorporated, the name Interlachen chosen and articles signed.

Work was begun on the grounds in March of 1910 and the clubhouse in November of that same year. The clubhouse and nine holes were formally opened on July 29, 1911. The course was designed by William Watson, a noted golf architect, and with the exception of a few minor changes, remains as originally built until 1919.

In 1914 Interlachen hosted the first of several major tournaments, the Western

Open. This event was followed shortly in 1916 by the Trans-Mississippi tourney, won by Harry Legg, a leading amateur of that day. Due to changing times and ideas in the world of golf, in 1919 the club undertook a two-year program of rebuilding the course.

By 1930 Interlachen was ready for one of the severest tests of any golf course, the U.S. National Open. The contest made golf history that year, for Robert T. Jones, Jr. won the National Open with a score of 287 and completed his "Grand Slam" of golf. It attracted a greater audience than any National Open before that time and brought international recognition to the club.

In 1935 Interlachen was the scene of another memorable event, the Women's National Amateur Golf Championship. On this occasion, the club's own Patty Berg made a serious bid for the title, losing after a hard fight to the more experienced Glenna Collett Vare. Although only 17 at the time, Patty displayed an amazing ability and determination which has since

Continued on Page 13

### *New from ProTurf...*



A replacement product for Fertilizer Plus 101 BS Fungicide at a greatly reduced price!

Call your Tech Rep for details.

*Mike Redmond*  
Executive Technical Representative



624 North Oak Drive, Suite 207  
Osseo, Minnesota 55369  
Telephone: 612/424-9684

## INTERLACHEN from Page 12

won her many golf championships and the admiration of both her fellow golfers and the galleries.

In 1942 the National Open was again scheduled for Interlachen but the war intervened. Though handicapped with a decreased staff and membership, the club continued to operate. After the war, due to hardships caused by the depression, the clubhouse and course were greatly in need of remodeling and repair. Instead of offering only advice or criticism, members organized into teams and worked on the greens themselves. They cleaned up bunkers and dug out weeds, including a great deal of Poison Ivy. With the addition of more "greenkeepers", tees were rebuilt and greens resurfaced.

1986 will be the most recent of memorable years for Interlachen. The club will celebrate its 75th anniversary with a variety of club events and has the honor of hosting the 32nd U.S. Senior Amateur Championship in September.

Interlachen enjoys a long and rich local, national and international heritage, a fact particularly appreciated by its current membership, their guests and the clubs' employees.

---

## RECORDS AND EQUIPMENT

by JOHN HARRIS  
GOLF COURSE SUPERINTENDENT  
LAFAYETTE COUNTRY CLUB

Capital equipment at any golf club is a must in order to provide cost effective maintenance and keep playing conditions at its peak throughout the season.

However, the mere mention of "new equipment" can send a Greens Committee into orbit. True, today's unit can rival your chairman's Porsche; but, with a few well loaded rounds of ammunition, clubs and their memberships can be educated on your needs.

I started by simply planting a few seeds or burrs under the necessary chairs throughout the '85 season. It was no surprise to anyone when I came up with a grocery list of horse choking quality.

I then compiled our records on our existing equipment. Each unit in our shop has a full record of repairs, maintenance and its costs. These costs of repairs were listed and totaled to reflect the percentage of cost on the original price tag. In your mind, you know they need replacing but, when you actually got it down on paper and found that some units exceed 30% of their original cost, I wonder how the budget ever survived.

I then took a close look at our budget figures in the areas of equipment rental, repairs and maintenance over a five year period. They had escalated at an average of 18% per year. With this in mind (more like infuriating my mind) I listed areas of the budget where we could save money..or, the "payback" on a new unit. They were given in either annual, five years, or ten years payback periods, depending on the life expectancy of the unit, and room for depreciation.

When I took this information to my superiors, it was easy to lay out all the cards on the table, as I had sound reasons for each and every unit. It also goes to say there is no replacement for good sound record keeping. All data collected was easily accessible and accurate.

At this writing the final seal of approval is yet to materialize. All preliminary indicators see this as just a formality. Even so, I have still got my fingers crossed, and plenty of spare keys to the tool box on hand.

---

## R. L. GOULD GETS AWARD

The R. L. Gould & Company, St. Paul, Minnesota won a service award from Jacobsen Division of Textron Inc. for outstanding facilities and service of Jacobsen professional turf equipment. The award was presented February 1, 1986 at Jacobsen's Annual Distributor Awards Breakfast held in conjunction with the 57th Annual Turfgrass Conference and Show in San Francisco.

R. L. Gould and Company distributes and services Jacobsen professional turf equipment which is used to maintain golf courses, parks, cemeteries, schools, stadia and other large turf areas.

# GROUNDS FOR RANSOMES!



THE LIGHTWEIGHT LEADER IN TRIPLEX MOWING

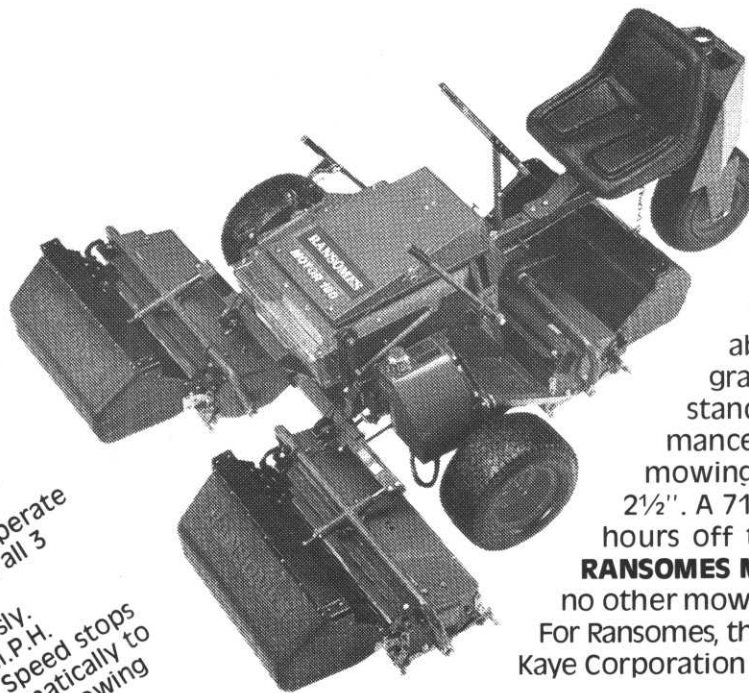

## CHECK THESE OUTSTANDING FEATURES!!!

- ✓ Hydrostatic drive with infinitely variable grounds speed.
- ✓ Economical 11 H.P. Gasoline Engine.
- ✓ Single, easy to operate P.T.O., engages all 3 cutting units simultaneously.
- ✓ Rapid 6½ M.P.H. Transport Speed stops down automatically to your pre-set mowing speed.
- ✓ Over 2 acres an hour of productivity.
- ✓ Two individual wheel motors for superb hillside traction, and maneuverability.
- ✓ Only 850 lbs. of Total Weight.

When professional groundskeepers talk of lightweight mowing they speak of the **MOTOR 180**. The lightweight leader for their mowing **handicaps**. The reel mower that offers real maneuverability. With a low center of gravity and wide track for outstanding stability and performance on steep slopes. Precision mowing at heights from ¼" to 2½". A 71" cutting width that slices hours off the biggest mowing jobs. **RANSOMES MOTOR 180**. On a par with no other mower. If you have the Grounds For Ransomes, then that's Grounds for calling Kaye Corporation your Ransomes Distributor.

When reliability is a "High Priority" Ransomes gives you . . .

- Widest choice
- Proven reliability
- Simple Operation!

FOR A "HANDS ON" DEMONSTRATION OF ANY OF OUR RANSOMES BOB-CAT MACHINES . . . CALL TODAY

**SPECIAL LEASING  
TERMS AVAILABLE  
ON THE COMPLETE FAMILY  
OF ALL RANSOMES  
PRODUCTS, REEL OR ROTARY**

Distributed  
Exclusively  
By



502 No. Front St.  
Mankato, MN 56001  
(507) 345-5083  
(612) 339-1179 (Mpls.)