

Meet
THE PRO-LINE MEN
In Minneapolis!



● All Pro teams need to have a strong line up front. Dependable men who can perform their assignment when the action in the "trenches" gets rough. Standard's front line is the best in the business because of experience, performance, and desire.

It may be cold in Minneapolis and the golf courses are under a coat of wet, cold snow. But at Standard, we think of golf 12 months of the year. So we line up ready to tackle any problem you might toss our way.

In the front is our chief linebacker . . . Robert Voorhees, (#66) President of Standard. Reading left to right is Steve Burrell, (#72); Bob (Chief) Waseskuk, (#77); John Christiansen, (#67) and M. K. Voorhees, (#16).

These pros will be looking for you at the (GCSAA) show in Minneapolis in February. Stop by our booth 500 for complete information. Our crew is ready to tackle any problem you might have even without shoulder pads or helmets!

Pro-Line
BY STANDARD

Standard Golf Company

220 East Fourth Street
Cedar Falls, Iowa 50613

You Could Drop a Bundle Figuring Only Cost Per Lb. When Buying Grass Seed

What about coverage? How many potential plants do you buy in a pound of seed?

Compare seeding rates (which gives you the potential number of plants) and divide by the price per pound. That gives you the true cost of a pound of seed.

That's where Highland Colonial Bentgrass shines. With 8 million seeds per pound its seeding rate is very low. Couple this with the fact that Highland is one of the most economical of the fine-bladed grasses and you'll see it offers the bargain of a lifetime.

Check it out. Compare the seeding rate of the fescues, bluegrass and ryegrass with their cost per pound. Find out how much you're really paying per 1,000 square feet and you'll take another look at Highland. The fine-leaved beauty that's truly a bargain.

Write for free brochures

HIGHLAND COLONIAL BENTGRASS COMMISSION

Dept. A • Suite 1 / Rivergrove Bldg. • 2111 Front St., N.E. • Salem, OR 97303

Circle 108 on free information card

courses being too long, too tough and too expensive to maintain. It did not make good sense to the golfers who had to pay the bills to have courses designed primarily for testing the championship capabilities of tournament specialists who were not paying for the courses.

When the reaction set in and American golfers began to think about an entertaining, testing and beautiful golf hole, the industry began to see that it had many good architects who created some classic results although not often given ideal terrain to work with.

Educational arguments have been developed about the features of a new course designed by Rees Jones, one of the gifted sons of Robert Trent Jones, and the famed father's design of the many courses. George Fazio presented some fascinating courses, among them the Butler National in suburban Chicago, where the Western Open will be played for several years. He is making a case for the good player as an architect and he has company in his class.

Keep Your Course Green

With Annual Ryegrass

Overseed with Annual Ryegrass and your course will be green again in a matter of days. Just the ticket for fairways . . . tees . . . and putting surfaces.

Plan on a bonus in addition to winter beauty. Ryegrass provides protection for the dormant native grass plants which might otherwise be ground out of existence in hard-use areas.

Ryegrass provides the protection to help your native grasses to snap back more rapidly when the warm weather returns.

Sow Ryegrass under unfavorable wet or dry conditions, and you'll see it germinate in a matter of 5 to 14 days, depending on conditions.

For More Information See Your Favorite Seedsman
For Free Brochures Write To:

OREGON RYEGRASS COMMISSION

Dept. 1, Suite One / Rivergrove Bldg. / 2111 Front St. N.E. / Salem, Oregon 97303

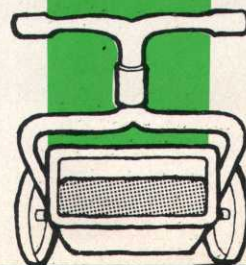

Circle 121 on free information card

PERFECT PICKER

**The Revolutionary NEW
Golf Ball Retriever !**

Pictured:
Three-gang Model



Available in Five-Gang, Three-Gang, Walker & Lake-Picker Models

Labor Saving

Pushed by an ordinary golf cart at 8 mph, each gang can retrieve 20 balls at a time. Gangs on similar units are limited to 12.

Ball Saving

Tractor-hauled units push balls into mud, making recovery & cleaning difficult. Balls are sometimes damaged. Not with PERFECT PICKER!

Maintenance Saving

Detachable in seconds, one-gang repair doesn't halt operation. Remaining gangs can keep working. Low maintenance.

Fuel Saving

Light-weight PERFECT PICKER picks clean in fewer sweeps because of its unique, flexible design. Saves fuel!

Safe To Use

The unit rides on smooth plastic disks; will not damage sprinkler heads, dig up turf, or ruin the plastic liners in lakes.

Ball Recovery

Reduce your ball inventory. PERFECT PICKER retrieves balls from uneven ground, next to fences, even from lakes.

Ask Your PERFECT PICKER Distributor For An Audio-Visual Demonstration

TIECO
Birmingham, Alabama

TIECO
Montgomery, Alabama

TIECO
Nashville, Tennessee

TIECO
Pensacola, Florida

TIECO
Jacksonville, Florida

TIECO
Orlando, Florida

TIECO
Miami Springs, Florida

GOLF CAR SALES
Norton, Ohio

ROBISON'S
Grandview, Missouri

NEWTON COMPANY
Denver, Colorado

WATSON DISTRIBUTING COMPANY, INC.

Dallas Texas

San Antonio, Texas

Houston, Texas

PERFECT PICKER CORP.

18279 Parthenia St. Northridge, CA 91324
Telephone: (213) 885-0111

NEW PRODUCTS

TRADITIONAL and contemporary seating for the country club comes from Buckstaff. Utilizing the durability and rich tones of solid oak along with the array of easy-to-care-for fabrics of today, Buckstaff furniture can become an asset in the clubhouse.



Circle 701 on free information card

CELEBRATING the Bicentennial with a flair is the idea behind a new red, white and blue golf flag from Lewis Line. Seven-feet in height, a white fiberglass pole features three color striping. The colorful flag has red and blue stars on a white field with USA/200 emblazoned on it. Flag material is nylon.

Circle 702 on free information card

A FULL line of club repair products comes from Golf Day and the Illinois firm is announcing a new Super Stripper that will remove old finishes faster. Golf Day Super Stains are also available in a number of colors including black, cherry red, mahogany and walnut.



Circle 703 on free information card

BUILT to take the every day punishment a country club golfer can dish out, Fore carpentering by Crown Industries can handle the gouging and twisting of spikes without showing wear. Constructed of

hardwearing 100 percent continuous filament olefin pile on a reinforced non-stretch vinyl back, Fore is stain-resistant and easy to clean. Eight colors are available, ranging from red to gold.



Circle 704 on free information card

PRODUCTIVITY and profitability go hand-in-hand in the T.C.A. Aerator from Dedoes. Providing one-day course aeration, the T.C.A. unit can aerate any tee or green in 15 minutes. Two units are available, one for tees and greens and one for fairways. Able to operate in either forward or reverse, the fairway model can remove 180 clean plugs per revolution.

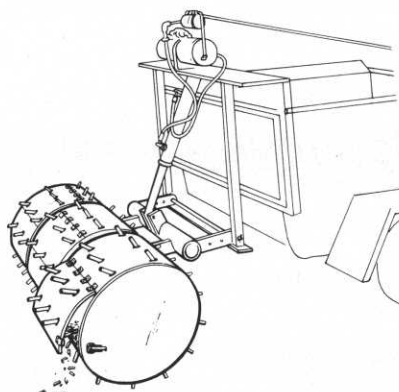

Circle 705 on free information card

BOOSTING your soft goods sales is a snap with Grand Paws athletic hose from Clossco. Seven different

styles are available, five men's and two women's. Retail prices for the hose range between \$1.50 to \$2 per pair. Styling varies from solid white to white with multi-colored stripes. The hose are a blend of nylon and Orlon®.

Circle 706 on free information card

WANT a sauna, but don't want to bother with the added cost of installation, Helo-MacLevy has a new "Do-It-Yourself" pre-cut room kit on the market. Just supply Helo-MacLevy with the room dimensions and they furnish all material, pre-cut, along with illustrated installation instructions.

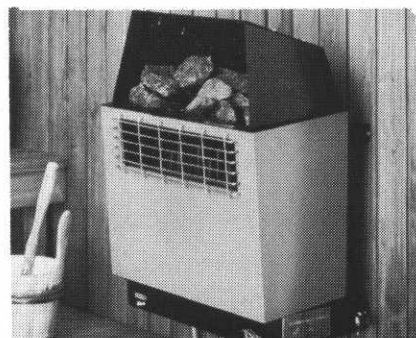

Circle 707 on free information card

INCORPORATING a design feature that helps the golfer point exactly toward the cup, the Win Putter from Jonal could be a big mover in the pro shop. Investment cast of stainless steel and silicone bronze, the putter is available in either right or left hand models.

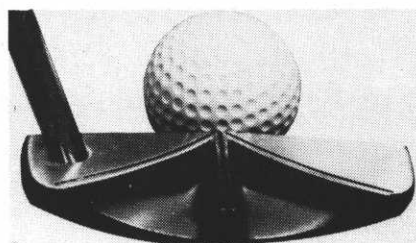

Circle 708 on free information card

EXTENDING vehicle battery charges to new highs is the job of the

"Big Forty" charger from Lester Electrical. On one charge, the unit can charge a 36 volt battery, up to 300 amp-hour types, to ¾ capacity in less than five hours. After the peak charge, the unit rate automatically tapers down to three amps, preventing overheating and excessive gassing. Use for both utility vehicles and golf cars is ideal.

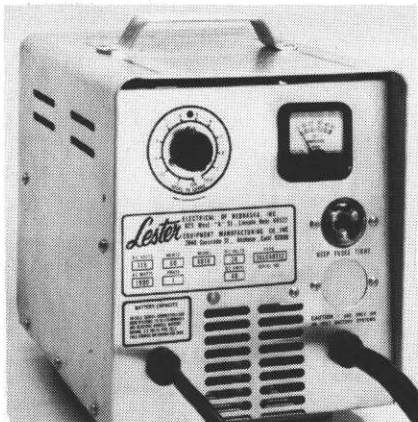

Circle 709 in free information card

INCREASE shop hat sales with new Poplin Roll-Up hats from Mayflower-Medalist. Imported from abroad, the headwear has a suggested retail of \$2.50 each.



Circle 710 on free information card

WEIGHING less than 25 pounds and with a retail price of around \$100, the Caddyloc motorized golf bag carrier is an innovation from Electric Sports Products. The unit has fingertip control and can make any grade easily.



Circle 711 on free information card

EMPTYING holding tanks is a thing of the past with the Envir-o-Pak comfort station by Modular Conceptual Systems. Through a biological process within specially designed toilets, the system needs no domestic water service or need of flush water removal.

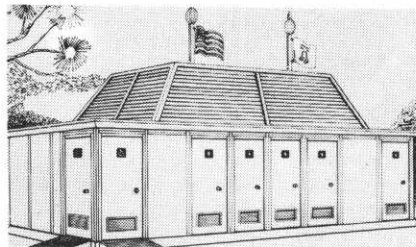

Circle 712 on free information card

AFTER several years of testing and research, AMF Ben Hogan has finally entered the durable golf ball market with its new Leader® model. The ball has the distance, trajectory and consistency of the tour-favorite Apex ball. The cover has a unique blend of thermoplastic resins, developed to give the product a good sounding, great feeling cover.



Circle 713 on free information card

COMPACT and portable, the Port-A-Rake from Al Sal Corporation provides the considerate golfer the ability to maintain sandtraps when course rakes are misplaced or taken. Made of rigid polypropylene, the 8-inch rake fits into its own small package when not in use.

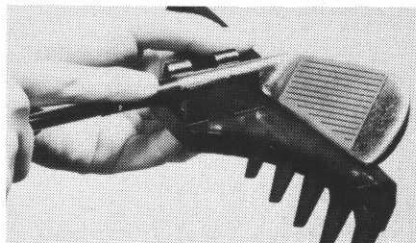

Circle 714 on free information card

FAIRWAYS and tees can get better spraying quality with two, new fiberglass units from Myers. Both models are easy to mount on the back of all utility vehicles. Lightweight and easy to handle, the sprayers include stainless steel booms with dripless nozzles, spray guns, anchor mounting kits and trailer kits.



Circle 715 on free information card

REDUCING service time and cost, Scotsman introduces an ice machine with complete front service access. The AC30 Cuber has all its major operating components located in a convenient slide-out chassis located behind a front panel. Daily cube production is up to 265 pounds.

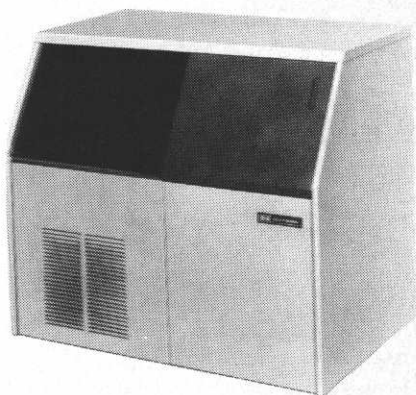

Circle 716 on free information card

FITTING the full range of irons in tip diameter and flex uniformity, Babcock & Wilcox introduces three new graphite shafts for irons. The first fits 2-4, the second 5-7 and the third 8-PW. The biggest plus of the shaft is its torque resistance.

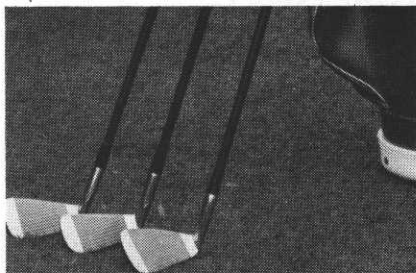

Circle 717 on free information card

CLASSIFIED

Rates: All classifications 50¢ per word. Box numbers add \$1 for mailing. All classified ads must be received by the Publisher before the 10th of the month preceding publication and be accompanied by cash or money order covering full payment.

BUSINESS OPPORTUNITIES

GOLF COURSES: Want to buy or sell a golf course? Our business is exclusively golf courses transactions. We also do golf course market value appraisals. McKay Realty — GOLF AND COUNTRY CLUB PROPERTIES. 15553 N. East St. (U.S. 27), Lansing, Mich. 48906.

HELP WANTED

POSITION OPEN for experienced golf course superintendent, to manage, program and administer 36-hole golf course in Silver Spring, Maryland area. Job is now vacant — applicant, when interviewed should present past records of budget and programming. Salary and benefits applicable to scope of job. Send resume to: Paul M. Yentis, 8720 Georgia Avenue, Suite 410, Silver Spring, Maryland 20910.

MISCELLANEOUS

GOLF CAR TIRES First line 18 x 8.50-8, \$14.50; 18 x 9.50-8, \$14.75 plus F.E.T. Send for our complete tire line. All sizes available. Golden Triangle Sports, Inc., 6317 Library Road, Library, Pa. 15129. Phone 412 835-6898.

GOLF COURSE DESIGN and renovation, irrigation system design and modification of existing systems, cost estimates. William M. Martin, 2009 Southshore Drive, Benton, Arkansas 72015. Phone 501 778-4452.

GOLF CART FLOOR MATS. New nylon plied, reinforced rubber mats for Harley carts, \$12.75 per set. C.O.D. or send check to Rice Die Cutting Co., 8831 33rd. Avenue, Kenosha, Wisconsin 53140. F.O.B. Kenosha.

WANTED: Golf related items to distribute to golf courses in Kansas, Oklahoma, and Missouri. Golf Services Unlimited, 7808 Nantucket, Wichita, Kansas 67213.

GOLF HEADS — Persimmon, laminated; supplies. Louisville Golf Club

Co., Inc., 352 Production Ct., Louisville, Ky. 40299. Phone 502 491-1631.

LEGAL NOTICES

ADVERTISEMENT FOR LEASING PROPOSALS involving the design, construction, operation and maintenance of a regulation 18-hole golf course at the Stony Creek Metropark Oakland County, Michigan. Proposals will be received by the Huron-Clinton Metropolitan Authority, 3050 Penobscot Building, Detroit, Michigan 48226 until 2:00 p.m. (Local Time), Thursday, March 25, 1976, from Proposers able to show a reasonable acquaintance with and an ability to successfully execute the requirements herein described. This project involves the leasing of lands within Stony Creek Metropark for purposes of designing, constructing, operating and maintaining a Regulation 18-Hole Golf Course. Proposal Forms, Location Plans, Soil Survey and Topographical Information may be obtained at the above address on or after December 9, 1975. Each Proposal shall be accompanied by a signed Proposal to Lease as verification that the Proposer will enter into a Lease Agreement. After the time of opening, no proposal may be withdrawn for a period of one hundred eighty (180) days. The Authority reserves the right to reject any or all proposals, to waive irregularities and/or formalities and to make award in any manner deemed for the best interest of the Authority. Huron-Clinton Metropolitan Authority, Robert L. Bryan, Secretary

WANTED TO BUY

WANTED: By experienced pro manager, Greenskeeper, golf course or driving range to lease or purchase. Box 62, Golfdom, 9800 Detroit Ave., Cleveland, Ohio 44102.

POSITIONS WANTED

GOLF PROFESSIONAL — PGA apprentice, age 44, 13 years golf experience, last 5 years in apprentice program, all phases pro shop operations and teaching. Seeking head professional position. Need only to take final examination for Class A membership. Will relocate, preferably southeastern United States. Available now. Box 68, Golfdom, 9800 Detroit Ave., Cleveland, Ohio 44102.

CLASS A PGA GOLF PROFESSIONAL seeks new employment at active club, either private or public. Age 35, 12 years experience in all phases of golf course operations, including complete management of entire golf course and club operation. Presently employed as pro-Supt. Available immediately or in spring of 1976. All replies answered and kept confidential. Box 56, Golfdom, 9800 Detroit Ave., Cleveland, Ohio 44102.

YOUNG GREENSKEEPER — Looking for advancement. Presently employed as assistant Superintendent on 18 hole course. Associate of Applied Science Degree in Horticulture — Grounds and turf. 3 years superintendent experience 4 years previous experience. Married; no children. Box 61, Golfdom, 9800 Detroit Ave., Cleveland, Ohio 44102.

PRO — SUPERINTENDENT, P.G.A. — G.C.S.A.A. member over 20 years — outstanding success. Now at top prestige club, prefer family type country club in the south. A-1 references and resume. Write 2322 Kingsland Drive, Doraville, Ga. 30340.

SUPERINTENDENT: desires 18 hole club or construction. Free to travel. 18 years experience includes 4 years of construction. Age 46, single. Familiar with maintenance and budget preparation. Reply Box 66, Golfdom, 9800 Detroit Ave., Cleveland, Ohio 44102.

CLASS "A". P.G.A. professional, 25 years, fully experienced teaching, clinics, golf shop operation, merchandising, golf course maintenance, tournaments, power cart maintenance. Available 1976 season. Box 64, Golfdom, 9800 Detroit Ave., Cleveland, Ohio 44102.

GENERAL MANAGER of recreational community desires change with organization offering greater challenge and opportunity. College graduate, strong business background, specializing in golf course and property management. Reply Box 57, Golfdom, 9800 Detroit Ave., Cleveland, Ohio 44102.

JOB WANTED, Class A P.G.A. pro, married, one child, 20 years experience, golf pro and greens superintendent, good teacher, promoter. Box 63, Golfdom, 9800 Detroit Ave., Cleveland, Ohio 44102.

GOLF COURSE ARCHITECT'S GUIDE



Member: American Society of
Golf Course Architects



11 South LaGrange Road
LaGrange, Illinois 60525
Telephone—Area Code (312) 352-2113

Circle 174 on free information card

P.G.A. SENIOR PROFESSIONAL desires position to assist head professional with teaching merchandising, clinics, tournaments, excellent teaching and sales ability. Box 65, Golfdom, 9800 Detroit Ave., Cleveland, Ohio 44102.

FORMER WORKING greens superintendent desire job as green superintendent, 20 years experience, will relocate any place on east coast. 5460 Curry Ford Rd., Orlando, Fla. 32806.

CLUB MANAGER, fourteen years experience, food and beverage, pro shop and golf course. Dennis Hogan, Box 505, Naples Florida 33940. Phone 813 774-6410.

GOLF COURSE SUPERINTENDENT: or assistant 27, single. Four seasons experience. B. S. Horticulturer. Philip Eyer, 1507 Carroll, Ames, Iowa.

GOLF PROFESSIONALS, Man-wife, available in '76 — located anywhere. Box 67, Golfdom, 9800 Detroit Ave., Cleveland, Ohio 44102.

FOR SALE

USED GOLF CAR CLEARING HOUSE. We have every make and model golf car in stock. If we don't have the golf car you want we will get it. Write or call collect for the golf cars of your choice. As is or reconditioned. Any quantity at the lowest possible prices and we handle the freight. NEDA Northeast Dealers Association. 420 Penn Street, Spring City, Pa. 19475. (215) 935-1111.

GOLF COURSE CONSTRUCTION

Building throughout the U.S. and Central America. Contact us.



IBERIA EARTHMOVING SERVICE, INC.

IBERIA, OHIO • Ph. Galion, O. 419 468-5454

Circle 151 on free information card

EDMUND B. AULT Ltd.

GOLF COURSE ARCHITECT

Sculptured Greens

Member

American Society of Golf Course Architects

National Golf Foundation

7979 Old Georgetown Road

Bethesda, Maryland 20014

301-942-0716

301-657-4278

Circle 145 on free information card

FOR SALE — 18 hole championship golf course with automatic irrigation system. Buildings (clubhouse, Pro Shop, two maintenance buildings and two story residence) and equipment in new condition. Dining room and cocktail lounge overlook course with seating 180. Banquet room — 80. 142 acres with 40351 frontage on U.S. Highway in Chicago Area. \$2,000,000. Terms available. Call Leon McNair 312 554-1100.

18 HOLE GOLF COURSE in southern California. Sacrifice — owner must sell! Write Bartsas Realty, Inc., 528 East Oakey Blvd., Las Vegas, Nevada 89104. Call 702 735-6377.

FORGED HEADS chrome finished—several stock models. Custom available for production runs only. Box 172. Forestville, Conn. 06010.

REAL ESTATE

WILL LEASE OR BUY golf course in Central Wisconsin. P.O. Box 558, Park Ridge, Illinois 60068.

GOLF COURSE BUILDERS OF AMERICA



BOB
VINCENT
Benton, Pa., says:

"For quality golf construction seek a member of the Golf Course Builders of America."

Request a free biographical-pictorial directory of the nation's leading builders.

GOLF COURSE BUILDERS OF AMERICA

725 15th St.N.W. / Washington, D.C. 20005

Phone 202 / 638-0555

Circle 154 on free information card

**PARTNERS
in PROFIT!**

Ballomatic

This all-purpose, self contained golf ball dispenser automatically washes, counts, stores and dispenses balls into baskets for your customers! Operates by coins, tokens or remote control.

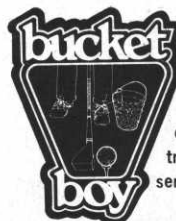

Modern automatic self-contained golf ball dispenser, for dispensing any quantity from 10 to 60 balls for any number of quarters or tokens. Also remote control. This time-saver upgrades service and increases profit!

CALL or WRITE!
Ask for FREE literature and details.
PH.(219)234-0075

TEUTONIX INC.

P.O. Box 1895
South Bend, IN 46634

Circle 133 on free information card

ADVERTISER'S INDEX

Advanced Drainage Systems, Inc.....	51
Edmund Ault	57
Babcock & Wilcox Co.....	46
Brouwer Turf Equip. Ltd.....	48
Chemagro Div.	17
Chicopee Mills, Inc.....	19
Crown Industries.....	50
Cushman Motors Div.....	47
ESB Brands, Inc.....	30-31
Foley Mfg.	18
Golf Course Builders of America	57
Goodall Div.	19
Hahn, Inc.	23
AMF Harley-Davidson.....	29
Highland Bentgrass Commission	52
AMF Ben Hogan Co.	8-9
Hollrock Engineering	48
Holsclaw Bros., Inc.....	18
Iberia Earthmoving Service	57
International Seeds, Inc.	49
Jacobsen Mfg. Co.....	35
Keller Golf Club, Inc.....	5
Maddox Construction	58
Manhattan Ryegrass Growers Association	26
Mallinckrodt Chemical Works ..	41
International Stewart In-fra-red Assoc.	37
Oregon Ryegrass Commission ..	52
Ottawa Silica Co.	12
Packard, Ind.....	57
Par Aide Co.....	7
Perfect Picker Corp.....	53
Quality Metal Products	15
Rain Bird Sprinkler Co.	25
Rhodia, Inc.....	39
Ryan Turf Equip.....	21
Shamrock Golf Co.	18
A. G. Stafford Co.	18
Standard Golf Co.....	32
Taylor-Dunn Mfg. Co... 2nd cover	
Tee-2-Green Corp..... 4th cover	
Teutonix, Inc.....	52
Trojan Battery Co. 3rd cover	

MADDOX

CONSTRUCTION COMPANY

**GOLF COURSE
CONSTRUCTION
BY CONTRACT**

Since 1924!

P.O. BOX 66
ST. CHARLES, ILL.
312-231-2665

212 W. FAIRCHILD
DANVILLE, ILL.
217-442-2411

Circle 150 on free information card

PEOPLE IN THE NEWS

William Johnston is director of golf for **Arizona Biltmore** golf complex, Phoenix. . . West Hilzer is pro at **Waterwood Country Club**, Lake Livingston, Texas. . . Kenneth Bradfield has been appointed marketing manager of the new TURF/AG Division of **Hahn, Inc.**, Evansville, Ind. . . George (Tip) Kockentiet

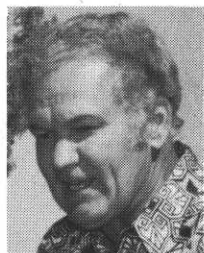

Johnston



Hilzer

has been named territory manager for **Dunlop Sports Co.** for Kentucky and western West Virginia. . . Jack Smith is superintendent at **Carolina Springs Country Club**, Fountain Inn, S.C. . . James Mitter is superintendent at **Calumet Country Club**, Homewood, Ill. . . Ed Compton, who serves Minnesota and the north central portion of the country for **Etonic**, has earned the distinguished salesman award. . . Luca Barbato and Charlie Dugas have resumed handling golf pro duties at their club — **Acadian Hills Country Club**, Lafayette, La. . . Robert E. Miller is manager at **Waupaca Country Club**, Waupaca, Wis. . . Jimmy Wright is pro at **Fenway Golf Club**, White Plains, N.Y. . . **Pargo, Inc.**, Charlotte, N.C., has named Edward V. Bannigan executive vice president of operations. He formerly was president of Ross Products, importer of Melex golf cars. . . Larry Runyan is superintendent at **All Seasons**, Lake of the Ozarks, Kan. . . Buddy Weaver of **Pine Forest Country Club**, Houston, is president of Gulf Coast Chapter of the Southern Texas PGA Section. . . Jim Ford is **PGA/Victor** salesman of the year. His territory includes Arkansas, west Tennessee, Louis-

iana and Mississippi. . . Jerry Sheridan has been named director of merchandising for all **Dunlop Sports** products. . . Apprentice Joe Bryant has taken over the top pro job at **Marshall Lakeside Country Club**, Marshall, Texas. . . Tommy Martty, pro at **Briarwood Country Club**, Baton Rouge, La., has been selected by the Louisiana Chapter of the Gulf States PGA Section as pro-of-the-year. . . Terry McGowan is pro at **Onion Creek Country Club**, Austin, Texas. . . Ralph Maas is superintendent at **Saukie Golf Club**, Rock Island, Iowa. . . William Hambery is manager at **Chattanooga Golf and Country Club**, Tenn. . . John Paisant is manager at **New Orleans Country Club**. . . Bill Macko is pro at **Albion Country Club**, Albion, Neb. . . Paul Xiques is general manager at **Oak Hills Country Club**, San Antonio, Texas. . . Harry Forsythe is general manager at **Country Club of Missouri**, Columbia. . . Jerry Letze is superintendent at **Valley Oaks Country Club**, Clinton, Iowa. . . Lou Michaels is pro at **Treasure Lakes Country Club**, Dubois, Pa. . . Ron Weber is pro at **Woodlands Country Club**, Conroe, Texas. . . Bob Mix of **Albany Country Club**, is president of Northeastern New York PGA Section. . .



Bradfield



Kockentiet

Bob Larsen is pro at **Country Hills Country Club**, Prior Lake, Minn. . . John Morrison is manager at **Hidden Valley Lake Country Club**, Middletown, Calif. . . John Pappas is manager at **Colonia Country Club**, Colonia, N.J. . . Lee Martin is pro at **Los Altos Golf and Country Club**, Los Altos, Calif.

For ad on following page circle 127 on free information

THE BIG FOUR IN GOLF



Over fifty years of engineering and manufacturing experience are reflected in the quality and reliability of Trojan "Mileage Master" Golf Car Batteries — This is why, today, Trojan is the recognized leader in the golf car battery field. For further information call toll free 800-423-6569 — in Calif. 213-945-1471

TROJAN BATTERY COMPANY • 9440 ANN ST. • SANTA FE SPRINGS, CALIF. 90670