

It's What's Below The Surface That Counts!

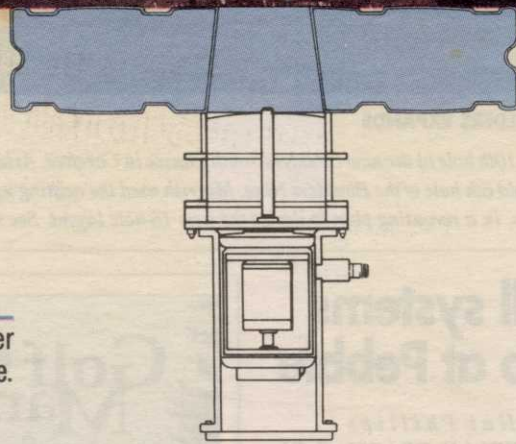

High Density Polyethylene Float:

Filled with US Coast Guard approved closed cell foam. Always floats level, stays afloat even if punctured or damaged. S/S fasteners provide longer life.

4 Pole/High Torque Motor:

Designed specifically for aeration. Runs longer and cooler at 1725 RPM. Easy to maintain. Rebuildable, not disposable.

Lubricating Oil:

Developed by a major oil company for lubricating and very low dielectric capabilities. Acts as heat transfer.

Power Control Center:

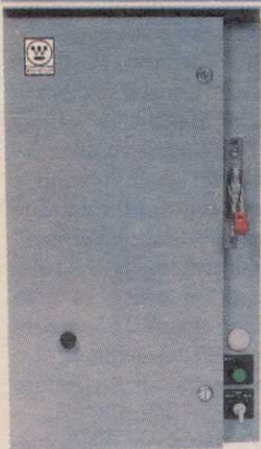

Exclusive Westinghouse motor controls provide maximum built-in protection. UL, CSA and ETL approved. Standard equipment, not an option.



Safety Tested:

All Otterbine aerators are safety tested and approved by ETL.

High Volume, Low Pressure Impeller:

Designed to aerate and move large volumes of water. Precision pitched Stainless Steel affords increased efficiency.

Plug-Type Underwater Connector:

Designed for Otterbine. Easy connect and disconnect makes installation and service simple.

Strong Distributor and Service Network:

Over 130 distributors nationwide with 35 service centers staffed by factory trained personnel.



Otterbine®
We are the competition.

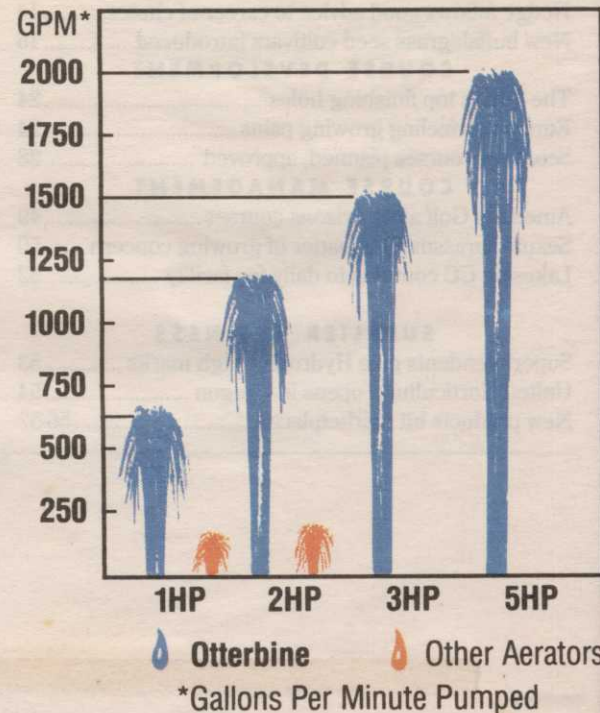

BAREBO, INC.

CIRCLE #101

P.O. Box 217, R.D. 2 • Emmaus, PA 18049 • Phone (215) 965-6018 • Fax (215) 965-6050



Tough On Diseases. Easy On You.

New Duosan® WSB is safer and easier to use—you handle only the bag, not the fungicide. And, the pre-measured soluble bags insure accurate applications every time.

Because each soluble bag contains both a contact and systemic fungicide, Duosan WSB is tough on

diseases. It's labeled to control a broad spectrum of diseases on turf, trees, shrubs and flowers.

Duosan WSB eliminates the need to purchase and store separate fungicides.

Order new Duosan WSB today.

Available in 12 oz. soluble bags (4 x 3 lb. case). Contact your Grace-Sierra distributor or call us toll free at 1-800-492-8255.

Make it easy on yourself. And tough on diseases. With Duosan WSB fungicide in water soluble bags.



GRACE SIERRA
Tournament Condition Every Day.

Duosan WSB is not yet available for sale in California. © 1991 Grace-Sierra Crop Protection Company. Duosan is a registered trademark of Grace-Sierra Crop Protection Company.

CIRCLE #109

Pre-emergents light goosegrass before it gets started

Yamaha wants you to know where we're coming from.



This-2 technology provides light weight, compact, fuel-efficient, and the flexibility of a conventional engine. The engine also provides virtually no maintenance or "lock-off". The result, more value from the battery you apply with an overall improvement in fuel quality.

For more information about This-2 batteries and their performance advantages, contact your local Tech Rep. Or call 1-800-543-0001.

Growing Better Through Technology

The reason has long been the benefits of battery cooling and efficiency, but now that performance comes in a premium price. With its unexcelled This-2 technology, Tech Reps can offer you the performance of advanced power cooling technology at a price comparable to traditional units. This-2 technology offers a superior alternative to lead-acid batteries, with extended service, excellent fuel economy, and more power-to-weight ratio. Tech Rep This-2 battery is a dry, dense, free-flowing, specially designed wet-cell technology, specifically designed for use with a standard generator. With This-2 technology, there's a natural potential for both low on-off and maintenance. And its "efficiency" of release results in a significant reduction in operating costs.



Georgia.

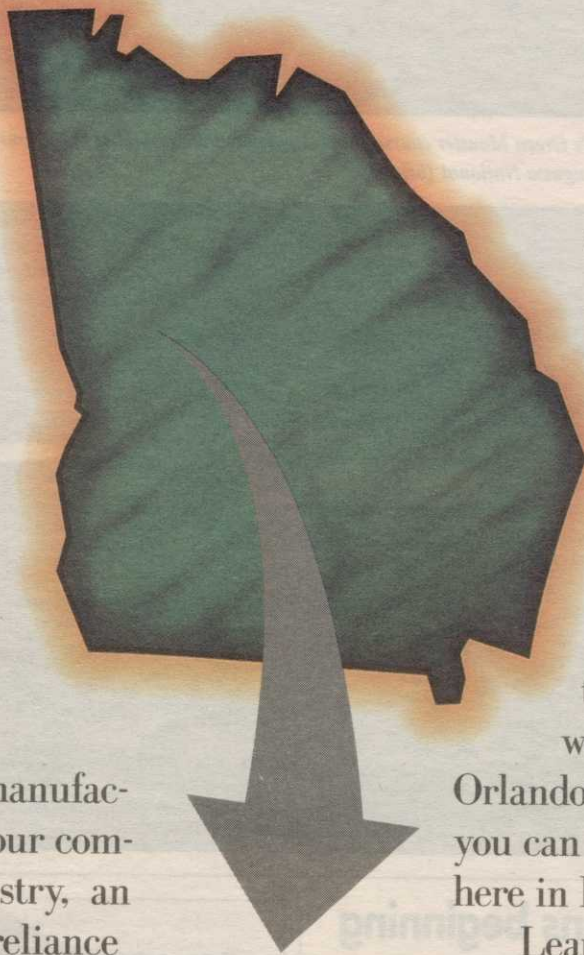

If you think Yamaha makes Japanese golf cars, maybe it's time you brushed up on your geography.

Truth is, Yamaha cars are made in America. By Americans.

Our expert teams roll superior golf cars off the assembly line every day in Newnan, Georgia -- the home of Yamaha's state-of-the-art manufacturing facility. It represents our commitment to the U.S. golf industry, an assurance of our continuing reliance on cutting-edge technologies.

We also take a future-minded approach to fleet-management. Our corporate size and golf industry experience allow us to tailor comprehensive financial pack-

ages for fleet operators. We, in conjunction with our nationwide dealer network, can help you advantageously invest in a fleet that maximizes revenue and return on investment.

The result is profit-building fleets in demand the world over. And whether we export those cars to Orlando, Florida or Osaka, Japan, you can be sure they were built right here in Newnan, Georgia.

Learn more about the efficient, reliable fleets made in our Georgia factory by calling 1-800-447-4700 for the Yamaha USA Golf Car Dealer near you. He'll show you proof that Americans do indeed make the world's finest cars.



YAMAHA USA
Better in the long run.

CIRCLE #115

UNIFORMS OF DISTINCTION



Custom embroidered & screened designs



SOUTHERN
CORPORATE PROMOTIONS

(404)487-8095 **800-233-3853**

CIRCLE #148



Golf Course Accessories

Ballwashers • Detergent • Mounting Pipes & Bases • Tee Signs • Spike Brushes • Hole Cutters • Flag Poles • Flags • Cups • Rakes • Benches • Tee Markers • Practice Greens Markers • Whipping Poles • Course Signage • And More.

Requested by players. Preferred by course professionals. Specified by designers and used with pride wherever golf is played.

Call your Par Aide dealer today for our **FREE CATALOG**, or call us at 612/779-9851 for the name of the dealer nearest you.

© 1990 Par Aide Products Co., St. Paul, MN.

CIRCLE #149

Plan now to attend these two exciting conferences

Marketing to Golf Facilities

A 2-day seminar loaded with ways to help you focus your marketing strategy to the golf course industry

October 4-6, 1992
Oak Brook Hills Hotel and Resort
Oak Brook, Illinois

Plan now to attend *Marketing to Golf Facilities*—a comprehensive seminar for vendors and suppliers to the turf industry.

- Learn the latest trends on the growth of golf facilities and key growth areas for the future
- Discover how superintendents and facility managers recommend, specify and purchase everything they buy—from chemicals to irrigation equipment
- Evaluate your strategy for reaching the golf market—and how to assess a successful marketing campaign
- Gain a competitive advantage in converting leads into sales

CIRCLE #150

Public Golf '92

The premier national conference for managers of public golf facilities

November 1-3, 1992
Oak Brook Hills Hotel and Resort
Oak Brook, Illinois

Don't miss this exciting conference to help you profitably manage, maintain and market the public course.

- Discover what's new—ideas, trends, and methods. A look at the bright future of public golf—and your part in it
- Examine profit minded planning, feasibility, expansion, and construction—and successful ways to finance it
- Get better results by learning new ways to manage and maintain your operation
- Develop a marketing strategy to dominate the market

CIRCLE #146

Send me more information on:

- Marketing to Golf Facilities
 Public Golf '92

Name _____

Title _____

Address _____

Phone _____

Fax _____

Return to:
Golf Course News Conferences
PO Box 997
Yarmouth ME 04096

or fax to 207-846-0657

or call 207-846-0600

Developed and sponsored by

GOLF COURSE NEWS

**DON'T
MAKE A
PUMPING
SYSTEM
PURCHASE
WITH ONLY
HALF THE
FACTS!**

For the complete picture call **THE LEADER IN VARIABLE SPEED TECHNOLOGY:**



FLOWTRONEX™

International

1-800-PUMP STATION

1-800-786-7782

CIRCLE #157



For mowing performance features, nothing else can make this cut.

Superior greens start with superior greens mower features. And the all-new Greens King® 422 is loaded with them.

Exceptional side-to-side, front-to-rear balance and a more compact roller base help accentuate your greens' details, rather than your mower's limitations.

Our new 11-blade, electronically balanced reel delivers an unbelievably smooth cut, even down to 5/64." Plus, our exclusive Turf Groomer® option simply produces faster, truer, healthier greens than any imitator.

Clutch performer.

No other walking greens mower can touch the 422 for reliability. Our all-new clutch has been tested out to the equivalent of 70 years of operation, without any adjustment or lubrication.

The same eye for quality extends throughout this unique machine—from our space-age, long-life bearings and

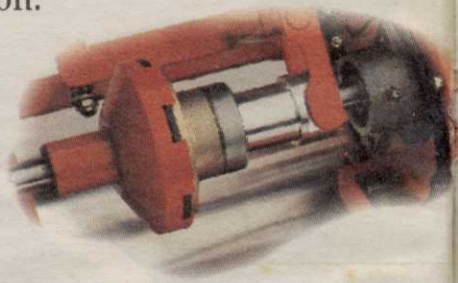

bushings, to the most durable drive belts made, to the powerful, high-efficiency 4-hp, 4-cycle OHV Honda engine.

With features like drop out drive drum, reel and bedknife, and easy, slide-apart traction roller with built-in differential, the Greens King 422 cuts maintenance time as neatly as it cuts grass.

See for yourself why it's a whole new ballgame, ask your Jacobsen distributor for a complete demonstration.

THE PROFESSIONAL'S CHOICE ON TURF.

JACOBSEN
TEXTRON

Jacobsen Division of Textron, Inc.

CIRCLE #158



IT'S A WHOLE NEW BALLGAME.

Ask About
NO PAY 'TIL
MAY 1, 1992
Thru
Participating
Distributors