

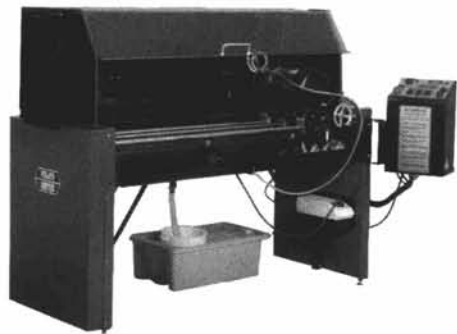

Accu-Pro Grinders



Bedknife Grinder- magnetic bed bar system for the straightest, most accurate grind possible.

630-773-5555
FAX 630-773-4273

Spin Relief Grinder - automatic indexing and a patent pending relief grinding mechanism provide dependable, accurate and fast unattended grind cycles.

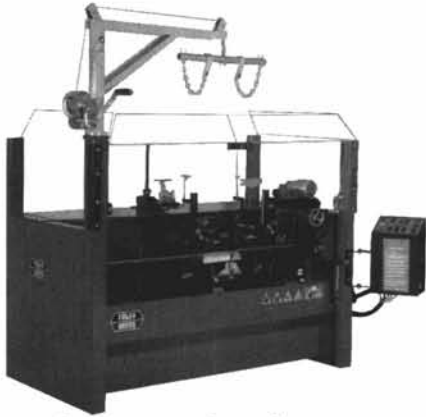

Chicago Turf & Irrigation Inc.
1170 W. Ardmore • Itasca, Illinois 60143



Reelmaster® 3100-D with Sidewinder Cutting Units



The next generation Reelmaster!
Cutting units slide left to right for greater cutting capability and maneuverability.



630-773-5555
FAX 630-773-4273

Chicago Turf & Irrigation Inc.
1170 W. Ardmore • Itasca, Illinois 60143

FEATURES

Now on the Internet
www.magcs.org



1999 BOARD OF DIRECTORS

PRESIDENT

Robert Maibusch (Cheryl)
Hinsdale G.C.

Home: 630-789-1651, Office: 630-986-1323

VICE PRESIDENT

Donald Ferreri (Geri)
Seven Bridges G.C.

Home: 630-357-7964, Office: 630-852-1746

SECRETARY / TREASURER

Brian Bossert (Pam)
Bryn Mawr C.C.

Home: 847-492-1138, Office: 847-677-4112

EXECUTIVE SECRETARY

George Minnis
MAGCS P.O. Box 760
Batavia, IL 60510

Office: 630-406-5356, Fax: 630-406-5456

BOARD

Dan Anderson (Catherine)
Fox Valley G.C.

Home: 630-554-7786, Office: 630-879-3332

Fred Behnke (Nancy)
Mount Prospect G.C.

Home: 773-774-1486, Office: 847-632-9331

Kevin DeRoo (Cheryl)
Bartlett Hills G.C.

Home: 847-697-0595, Office: 630-483-4991

Jim McNair

Orchard Valley G.C.

Home: 630-892-8389, Office: 630-907-8998

Luke Strojny (Debbie)
Poplar Creek G.C.

Home: 630-830-7370, Office: 847-310-3618

Greg Thalmann (Trudi)
Fox Run Golf Links

Home: 847-394-5410, Office: 847-228-3541

PRESIDENT EMERITUS

Kevin Czerkies (Peggy)
Sportsman's C.C.

Home: 847-949-7074, Office: 847-291-2352

COMMERCIAL REPRESENTATIVE

John Anderson

Turf Partners

Office: 630-231-8441

TURFGRASS ADVISOR

Dr. Randy T. Kane

University of Illinois & CDGA
630-954-2753

EDITOR: Fred D. Opperman

810 Greenwood Avenue
Carpentersville, IL 60110
Phone & Fax: 847-428-5009
Email: magcsoc@aol.com

On Course is published monthly. All articles, double-spaced, are required by the first of the month to make the next issue. Advertising is sold by the column inch, sixth page, quarter page, third page, half page and full page.

This publication is not copyrighted. We would like to share our articles with any who would like to use them, but please give the author and *On Course* credit.

FRONT COVER

Eighth hole, par 3 at Poplar Creek C.C.,

4 ON COURSE WITH THE PRESIDENT

Bob Maibusch

8 DIRECTOR'S COLUMN

Kevin DeRoo

10 SUPER -N- SITE PROFILE: Luke Strojny -N- Poplar Creek C.C.

Luke Cella

12 ASK THE "EXPERT": Tracking Soil Temperatures

Nick Hongisto

14 FEATURE ARTICLE: Your Irrigation System and the Illinois Plumbing License Law

20 Greenkeeping Instruction at State University of New Jersey

Howard B. Sprague

22 A Superintendent's Responsibility

Glenn Bereiter

26 THE BULL SHEET

Fred Opperman

The Midwest Association of Golf Course Superintendents (MAGCS), founded December 24, 1926, is a professional organization whose goals include preservation and dissemination of scientific and practical knowledge pertaining to golf turf maintenance.

We endeavor to increase efficiency and economic performance while improving and enhancing the individual and collective prestige of the members.

The MAGCS member is also an environmental steward. We strive to uphold and enhance our surroundings by promoting flora and fauna in every facet in a manner that is beneficial to the general public now and in the future.



You can play a round on us.

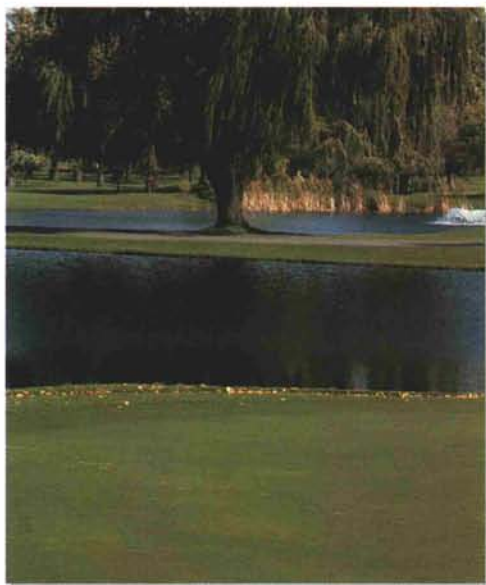

At H&E Sod we don't play around with our bentgrass so you can. All three of our bentgrass varieties meet the rigid USGA specifications. H&E grows all bentgrass on fumigated, native sandy loam type soil and they are *Poa Annua* free.

Penncross™ is known as the worldwide standard for putting surfaces. It is a fast growing, disease resistant, heat and wear tolerant bent sod.

Pennlinks™ is a great all purpose, upright growing bentgrass. It is disease resistant and wears like no other putting surface.

Penneagle™ is a fast growing, dark green creeping bentgrass, which is perfect for tees and fairways.

H&E also grows a variety of great bluegrass blend sods. Our new XL-2000, XL-100, and KY- 33 are second to none for beauty and ease of maintenance.

All H&E bent and bluegrass turfs are available as traditional cut or "Hydro-Cut", in regular or "Big-Roll" sod rolls.

For more information on H & E Sod call, fax, write or visit us on our Web site at www.hesod.com.

General Offices
3900 West 167th Street
Markham, IL 60426
708-596-7200
Fax 596-2481

North Suburban Sales
Depot & Warehouse
29800 North Highway 12
Wauconda, IL 60084
847-526-2300
Fax 526-2507

H&E SOD NURSERY
inc.

Midwest
SOD CULTURE

The Perfect Fit.



HERITAGE® and DACONIL®. The Fungicides That Fit Your Disease Management Program Perfectly.

Most all golf course superintendents puzzle over the right combination of disease control products for their turfgrass management program. Put an end to this dilemma with HERITAGE and DACONIL, the two broad-spectrum fungicides that fit your program perfectly. Together, HERITAGE and DACONIL bring just the right complement of advantages to your tees, greens, and fairways.

HERITAGE FUNGICIDE

- Exhibits both preventative and curative activity
- Only strobilurin chemistry with systemic activity
- Controls most turfgrass diseases, including Pythium, take-all patch, summer patch, anthracnose, and snow mold
- Reduced risk to environmental resources
- Extended spray intervals with low use rates
- Improves turf quality with no stunting or growth regulator effect

DACONIL FUNGICIDE

- Multi-site mode of action
- Sticks and stays for maximum protection against fungal diseases
- Controls 14 diseases, including dollar spot, leaf spot, melting out, rust, and red thread
- Three flexible formulations—Ultrex®, Weather Stik®, and Zn

When putting your turfgrass disease management program together, pick up HERITAGE and DACONIL fungicides—they're the perfect fit.

For more information, contact your authorized Zeneca Agent, or call Zeneca Professional Products Toll Free at 1-888-617-7690. Labels and MSDSs available 24 hours a day, seven days a week via Fax on Demand. Please call 1-800-640-2362.

www.zenecaprofprod.com

Heritage
FUNGICIDE

Daconil
Fungicide

ZENECA Professional Products

Always read and follow label directions carefully. DACONIL Ultrex®, DACONIL Weather Stik®, DACONIL Zn®, and HERITAGE® are registered trademarks of a Zeneca Group Company. © 1999. Zeneca Inc. Zeneca Professional Products is a business of Zeneca Ag Products, a business unit of Zeneca Inc.

ZPP-HER-009



Bob Maibusch, CGCS, MG
Hinsdale G.C.

As most of you are probably aware by now, Fred Opperman will be leaving his post as the Editor of *On Course* magazine sometime in the next few months. Fred and his wife Judy are moving to Montana to pursue new opportunities and dreams.

Rest assured that the Board of Directors and the Editorial Committee will do everything within their power to assure that the quality and timeliness of your magazine will continue. To that end, a search committee, headed by Jim McNair, was formed the day we received notice of Fred's resignation and has been hard at work identifying possible successors. Their collective attitude is to approach this challenge as an opportunity.

Instead of bemoaning Fred's departure, I believe it is an appropriate juncture to give thanks for the time that Fred spent serving the association in the capacity of Editor since 1983. Anyone who has served on the Board of Directors in the last 15 years can relate at least one story about the intimidating voice on the other end of the telephone line reminding you

that your "Director's Column" article was soon due, or, heaven forbid, late. For most of us, that call only needed to be made once during our Board of Directors tenure. A second transgression would have been too frightening to ponder. This, however, speaks volumes for Fred's dedication to providing a quality product, on time, month in and month out.

I will remember Fred as a consummate professional. He brought to the position a passion for excellence which translated into the magazine becoming an extension of himself. At times, we all took for granted the quality of work which he gave us every step of the way. Fred also occasionally found himself on the opposite side of the fence of some vocal critics of the magazine's direction. Oftentimes, people's visions of the future do not mesh, but through it all, nobody ever questioned his commitment to quality and the betterment of the magazine. A less principled individual, or a person of diminished resolve, integrity, passion or dogged determination, would have abandoned his position long ago. We may find another person to assume the role of Editor, but it is safe to say that Fred will never be replaced.

Appropriately, *On Course* was recently awarded First Runner-up in its competition category for chapter magazines through GCSAA. This is quite an accomplishment considering that the other magazines in this category generally have higher budgets and multiple staff members overseeing their production. Congratulations, Fred!

With sincere appreciation for all that Fred and Judy have done for the association, because I am sure that in more ways than any of us realized, she has been a signifi-

cant part of the collaborative effort in assisting Fred in maintaining such high standards, I wish them both the best of luck in the future.

Bob Maibusch, CGCS, MG
President, MAGCS

Take another look at the most complete selection of **Jacobsen *World Class* Greens Mowing Equipment**

Greens King V diesel
19.9hp Kubota engine, comfortable,
tight wheel base, light balanced design
11 or 7 bld *Flash-Attach* reels, 2 or 3
wheel drive. A versatile machine!



Greens King V gas
same as above, with a quiet
18 hp Vanguard gasoline engine



Greens King 522
4 hp Honda engine, loop handle,
improved drive train, integral OPC

Greens King 522T
same as above with a "T" handle
for superior balance and
maneuverability



Greens King IV plus
18 hp Vanguard engine,
power steering, and
11 bld *Flash-Attach* reels

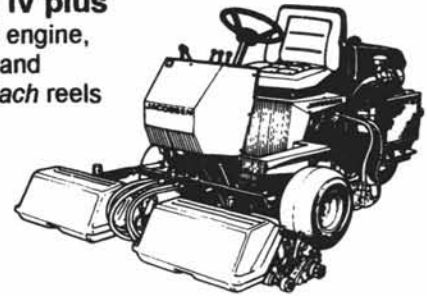

Greens King 518
for authentic recreation of the
surface that the course
architect envisioned

Greens King IV
proven performer, 16 hp Vanguard,
back lapping, 11 bld reels and
a new price

Greens King 526
H.D. 7 bld reels provide
superior cut for tees and
approaches

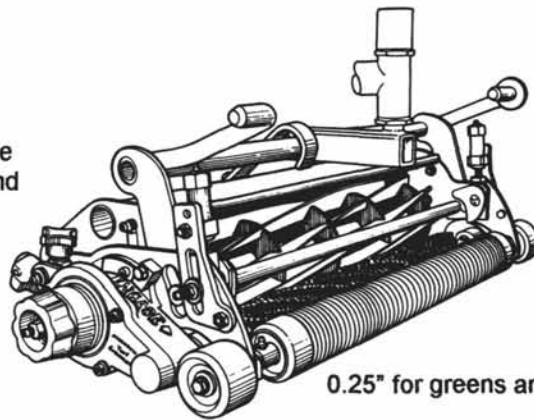

**Turf Groomer®
Greens Conditioner**

0.25" for greens and 0.50" for bent grass tees and fairways

THE PROFESSIONAL'S CHOICE ON TURF

**JACOBSEN
TEXTRON**

Jacobsen Division of Textron Inc.

and



**Illinois lawn
equipment inc.**

800-942-8610

120 Years of Combined Experience!

Keep Your Course In Top Condition...

Legacy Golf

Control water, labor and energy costs with a Legacy irrigation system. Century is your local distributor with a complete line of rotors, valves and controllers.



With Irrigation Supplies from

CENTURY RAIN AID

Sprinklers • Valves • Controllers • Fountains • Pump Stations • Controller Service Repair

Golf course superintendents like yourself are making plans to get their courses in top shape for the new season. And irrigation is at the top of their lists. Century golf professionals can show you how to maintain a highly-playable course, and can

help solve any irrigation or drainage problems. They can also show you what's new in clubhouse landscape lighting, water features and more. Call today for a FREE catalog and on-site consultation: **800-347-4272**.

Controller Board Repairs

Call Century when you need controller board repairs for Rain Bird and Toro golf controllers.



Replacement boards can be shipped within 24 hours. Call 888-855-9132.

SyncroFlo Pumps

An efficient pump station can solve many irrigation problems. Century now offers the SyncroFlo Eagle Series, the premier system for golf courses.



SyncroFlo, Inc.

Aqua Master Fountains

Improve water quality with an aerating fountain. Century can also show you how to create water features from existing streams or ponds.



Aqua Master
Superior Aquatic Management Systems

CENTURY RAIN AID

www.rainaid.com

800-347-4272

Now Serving these Major Markets: Alabama, Arkansas, Delaware, Florida, Georgia, Idaho, Illinois, Indiana, Kansas, Maryland, Massachusetts, Michigan, Minnesota, Mississippi, Missouri, New Jersey, New York, North Carolina, Ohio, Oregon, Pennsylvania, South Carolina, Tennessee, Utah, Virginia, Washington, West Virginia, Wisconsin and Ontario, Canada.

CENTURY GOLF PROFESSIONALS ♦ ILLINOIS/INDIANA > CAMERON BLAYNEY • ED KRUSE • MIKE PATTON ☎ 630-515-8555

> RANDY LANE ☎ 765-743-9599

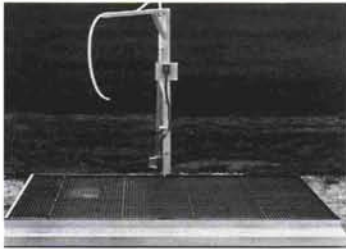

Our units are delivered ready for use after simple connection of utilities.



Computerized pump system keeps fluids within 1/4 inch depth, stainless steel removable screens filter large debris.

EAGLE CONTAINER CORPORATION
 4214 Rome West Rd.
 Chillicothe, IL 61523
 Tel. (309) 274-5273
 Fax (309) 274-4765

“Rinse, Reclaim, Recycle”

An innovative pollution solution

Approved by the
 State of Illinois Dept. of Agriculture

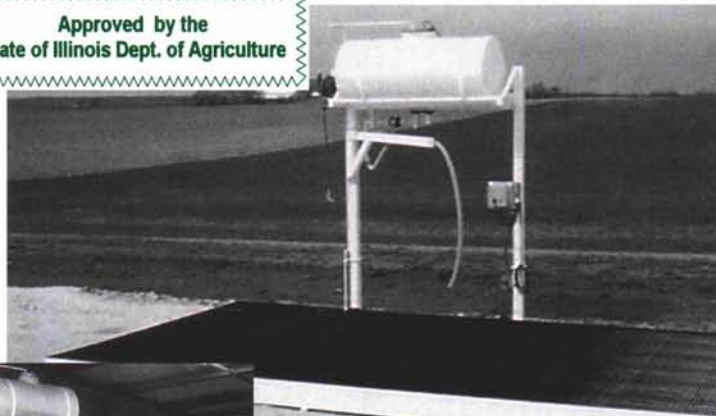

Environmentally correct process to reclaim tainted rinse water. Can be located anywhere

Continuous welded, solid steel construction will not crack like concrete. Each unit is coated with a chemical and UV-resistant paint. With 16 standard sizes available ranging from 8' wide x 8' long to 12' wide x 20' long. We can meet your needs.

Call for your state compliance sizing for your equipment

“U.S. Patent Pending”

RINSATE STATION

Hollembeak Construction, Inc.

Golf Course Construction and Remodeling

“We believe in a quality job and take pride in our finished product.”

- New Construction
- Feature Shaping
- Bunker Sand Replacement
- Pond Dredging
- Pond Construction
- Boulder Features
- Cart Paths
- Drainage

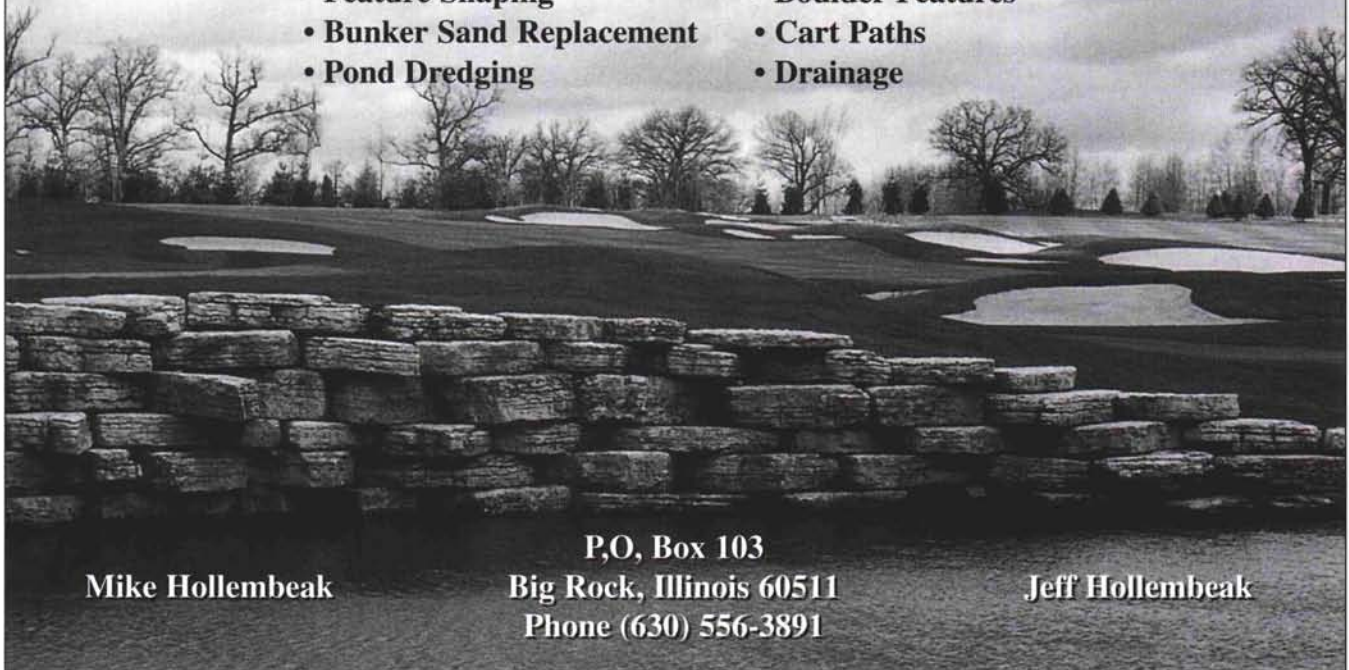

Mike Hollembeak

P.O. Box 103
 Big Rock, Illinois 60511
 Phone (630) 556-3891

Jeff Hollembeak



Kevin DeRoo
Bartlett Hills G.C.

One of the responsibilities of being a director for the Midwest Association of Golf Course Superintendents is coming up with a topic to write about for my "Director's Column." Now if you think about all the former directors and all the articles that have already been written, you will quickly realize that interesting and pertinent subject matter is becoming a relatively thin commodity. But as an elected official representing my fellow superintendents, I persevere; and in life, perseverance usually pays off, even if the unwritten story I have been looking for has been right under my nose all along.

I would like to tell you all an interesting story about an ordinary man. The story is not nearly as interesting as the man behind the story, but I will try. This is a man who has laughed in the face of despair on more than a few occasions. A man who would gladly share his life with anyone who will take the time to listen. A man who is now living out a childhood dream working on a golf course just by driving a tractor and mowing some grass along the way.

His name is Robert Ribbon, born September 20, 1924. Bob quickly fell in love with the game

of golf while growing up in his old neighborhood. He was raised in Chicago across the street from the Mid-City Golf Course (which is now the site of WGN Studios). Bob began caddying there at the age of 13. He continued to caddy all through high school and did so after he graduated until he was drafted that summer of 1943.

He became a Buck-Sergeant as a "tailgunner" in a B-17 bomber and was stationed at Foglia, Italy, with the 15th Airforce Division, 463rd Bomber Group,

*I would like
to tell you all
an interesting story
about an ordinary
man. The story
is not nearly
as interesting
as the man behind
the story, but
I will try.*

the 772nd Bomb Squadron. He flew seven missions over northern Italy and Austria in a B-17 bomber named "The Magnificent Malfunction." On April 20, 1945, returning from a bombing raid of a railroad yard in Innsbrook, Austria, The Magnificent Malfunction was struck by a 88mm German anti-aircraft shell and crashed. Of the nine-member crew, five survived; Bob was one of them. The five survivors were all captured, however, by German soldiers and sat out the rest of the war in a P.O.W. compound near Innsbrook. They remained there until being rescued by the 3rd Armor

Division on May 4, 1945, a few days before WWII ended.

After being discharged from the service, Bob became a carpenter's apprentice and learned the trade of carpentry, and worked as such until 1953 when he was sworn in as a Chicago police officer. After 27 years on the force, he retired as a Chicago police sergeant on March 1, 1980. During this time, he not only became a successful husband and friend to many but also a father of six children as well. During this time, he continued to play golf, and in 1964 he moved to the then tiny suburb of Bartlett strictly because of a little-known golf course called Bartlett Hills. In September 1982, Bob was hired on as a member of the Bartlett Hills Golf Course maintenance staff where he works to this day, living out his childhood dream and playing some golf along the way.

I know by now you are all asking yourselves, "Kevin, have you flipped your noodle? What does this have to do with a being a superintendent?" To you I say only this. As supervisors of many different people from many different backgrounds and cultures, I urge you all to get to know the people who work for you. You may be surprised and fascinated what you find. You will also discover that in getting to know the people who work for you, and with you, you may better utilize them to the best of their abilities. I would also like to say thank you to Bob for sharing with me your stories and friendship. I know my words alone could never do them justice. 

CLEAN UP SPILLS

WITH ENVIRONMENTALLY SAFE

SPILLAWAY+BRANDS™



Microbial Technology,
a better way for golf courses
to clean equipment,
turf and water spills,
parking lots, carts, (even golf balls).

"I highly recommend SpillAway+Products to my fellow superintendents". Ed Braunsky, Geneva Golf Club.

Palatine Oil Co., Inc. ■ P.O. Box 985 ■ Palatine, IL 60078
1-888-358-POC1 ■ FAX 847-358-5904

"One Call Does it All"



Construction Services to the Golf Industry

Your source for Golf Course Construction, Reconstruction & Improvement.

*You have the Projects, Ideas & Needs. We have the Experience & Equipment to do the job **Right the First time.***

*Many Trucks
Equipped with
High Floatation
Tires to
Minimize
Damage to your
Golf Course*



- New Construction
- Remodelling
- Irrigation
- Drainage
- Feature Shaping
- Trap Sand Replacement

- Water Control Structures •
- Pond Cleaning •
- New Ponds •
- Pond Lining •
- Cart Paths •



*Specialized
Equipment
suited to
Cleaning your
existing Golf
Course
Water
Features.*

CALL US TODAY!!

Lee Bruce

(608) 836-7041

Dave Weber

Established 1953

Luke Strojny -N-



*Luke Cella, CGCS
Pottawatomie G.C.*

Luke broke into the golf business as a caddy at St. Andrews Golf Club in West Chicago in the mid-'70s. His talent and perseverance was recognized, and he soon climbed up the ladder to cart boy. Shortly thereafter, Luke's career path took a turn when he made the change to the maintenance staff. He worked at St. Andrews under John Lapp for five years while at the same time earning an Associates Degree in Ornamental Horticulture from the College of DuPage in June of 1981.

At twenty-one years of age, Luke took the position of golf course superintendent at Maple Grove Country Club in West Salem, WI (located about 13 miles east of LaCrosse). He worked there for two years and then found himself at his present place of employment, Poplar Creek Country Club in Hoffman Estates, since 1984. Luke became certified by the GCSAA in 1987 and has kept this status current.

When I spoke to Luke, he was in the middle of working on bid documents for capital improvements at Poplar Creek. Soon he will be ready to fire up his new irrigation system that will be complete this spring. He is replacing a system that has major components over twenty-three years old.

Luke has been a board member of the MAGCS since 1995 and has chaired the Membership, Golf, and Arrangements Committees during that span. He currently chairs the Arrangements



Debbie, Julie, Kyle and Luke Strojny.

Committee, so we all have another reason to thank him besides hosting our monthly meeting.

Luke finds enjoyment in his work through his love for the outdoors, nurturing growing things, and the day-to-day challenges he faces. The one thing he wishes could change about the profession is the time spent away from his family. He has been married to Debbie since 1987, and they have two children: Kyle who is seven and Julia who is two. Luke coaches Little League in the spring and finds himself watching his son participate in soccer and hockey in their respective seasons.

(continued on page 24)

Custom Applications for Lime/Gypsum & Lebanon/ParEx Fertilizer

- Mass output is computer controlled
- Extremely accurate applications.
- 1000 lb. bulk bags available



Experienced and licensed applicator provided.



ARTHUR CLESEN INC.

543 Diens Dr. Wheeling, IL 60090
8050 W. 186th St. Tinley Park, IL 60477

(847) 537-2177 Fax: (847) 537-2210
(708) 444-2177 Fax: (708) 444-2199