

## Product Profile :

Greens King 518

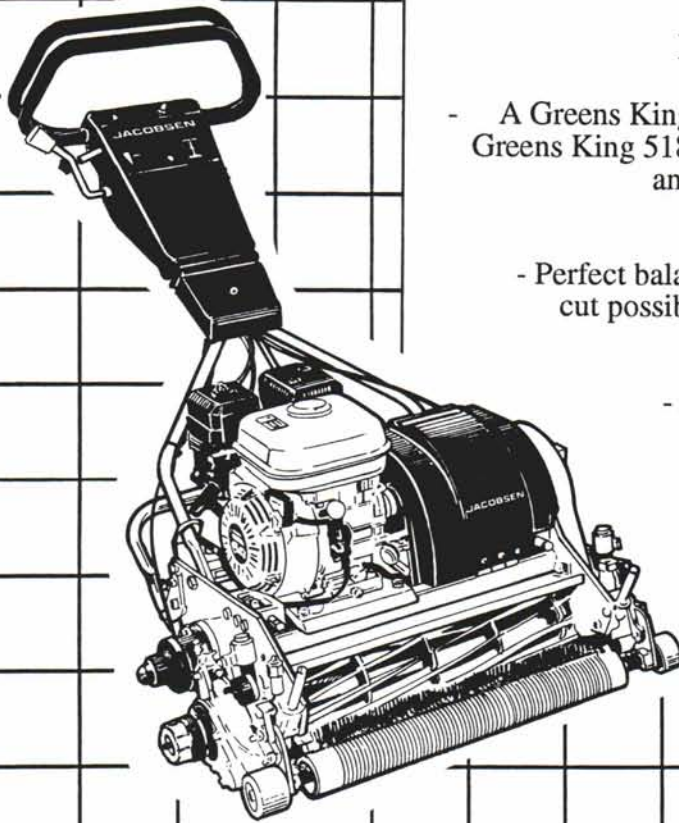

**Jacobsen's Greens King Walk-Behind Precision Mowers Give Your Formal Turf the Smoothest, Most Consistent Cut Possible - Every Time You Mow.**

- A Greens King to fit every need...18-inch Greens King 518, 22-inch Greens King 522, and 26-inch Greens King 526.
- Perfect balance for the most consistent cut possible. 11-blade electronically balanced reel.
- Integral OPC/clutch design for smooth starts and more control.
- Durable, 4-hp, 4-cycle CARB-approved engine.



**illinois lawn equipment, inc.**

16450 South 104th Avenue • Orland Park Illinois 60462

708-349-8484



**Technology Backed By Tradition**



## 1996 BOARD OF DIRECTORS

### PRESIDENT,

**Don Cross (Cindy)**  
Skokie C.C.

Home: 965-3435, Office: 835-4296

### VICE-PRESIDENT

**Ed Braunsky (Sue)**  
Geneva G.C.

Home: 879-8536, Office: 232-0627

### SECRETARY / TREASURER

**Kevin Czerkies (Peggy)**  
Sportsman C.C.

Home: 949-7074, Office: 291-2352

### BOARD

#### **Brian Bossert**

Bryn Mawr C.C.

Home: 312/274-4724, Office: 677-4112

#### **Donald Ferreri (Geri)**

Seven Bridges G.C.

Home: 357-7964, Office: 852-1746

#### **Robert Maibusch (Cheryl)**

Hinsdale G.C.

Home: 789-1651, Office: 986-1323

#### **Jim McNair**

Orchard Valley C.C.

Home: 892-8389, Office: 907-8998

#### **Luke Strojny (Debbie)**

Poplar Creek G.C.

Home: 830-7370, Office: 310-3618

#### **Greg Thalmann (Tudi)**

Fox Run Golf Links

Home: 394-5410, Office: 228-3541

### PRES. EMERITUS

#### **Joel Purpur (Debbie)**

Home: 832-6763, Office: 782-4259

### COMMERCIAL REPRESENTATIVE

#### **Philip Taylor (Marilyn)**

Illinois Lawn Equipment

Home: 983-9203, Office: 349-8484

### PHOTOGRAPHY

**Raymond Schmitz & John Meyer**

### TURFGRASS ADVISOR

#### **Dr. Randy T. Kane**

University of Illinois & CDGA

954-2753

All area codes are 708, unless noted otherwise

### EDITOR: Fred D. Opperman

810 Greenwood Avenue  
Carpentersville, IL 60110  
Phone & Fax (708) 428-5009

*On Course* is published monthly. All articles are required by the 1st of the month to make the next issue. Advertising is sold by the column inch, quarter page, half page and full page.

This publication is not copyrighted, and we would like to share our articles with any who would like to use them, but please give the author and "On Course" credit.

## FEATURES

### President's Message

by Don Cross

2

### COVER STORY

## On The Cutting Edge with Bob Williams

by Dave Blomquist

6

## A Letter from James M. Latham

12

## the Bull Sheet

14

## 1996 Committee Assignments

16

## Directors Column

by Kevin Czerkies

18

## The Turfgrass Program in Illinois

by Bruce Branham, Associate Professor, University of Illinois

22

## GCSAA Joins Pesticide Partnership Program

28

The Midwest Association of Golf Course Superintendents is a professional organization founded in 1927 whose goals include preservation and dissemination of scientific and practical knowledge pertaining to golf turf maintenance.

We endeavor to increase efficiency and economic performance while improving and enhancing the individual and collective prestige of the members.

The MAGCS (Midwest Association of Golf Course Superintendents) member is also an environmental steward. We strive to uphold and enhance our surroundings by promoting flora and fauna in every facet in a manner that is beneficial to the general public now and in the future.



# On Course with the President



Don Cross,  
President, MAGCS

**A** new era in our association's publication begins! The MAGCS is "*On Course*" to a higher level of professionalism, and to attaining an elevated presence within the golf community. It is without doubt an exciting time for us, and while I just happen to be President at this time, much of the credit goes to other individuals. We are grateful to Past President Joel Purpur, CGCS, for having the fortitude to challenge the status quo and seek a new, more befitting title for our magazine. To past Director Dave Blomquist, CGCS, and the entire Editorial Committee, and our Editor, Fred Opperman, we are indebted for their substantial effort in contracting a new printer, planning new layouts, introducing color, and more. Additionally, we thank the entire Board of Directors for approving this historic change and making the tough decisions. And, to you, the overwhelming majority of the MAGCS membership, we applaud you for embracing and supporting this move toward greater professionalism for our association. I'm proud of this accomplishment for the MAGCS and trust you are too! As experience is gained with each passing issue, you can expect even more improvements to "*On Course*". The Editorial Committee is poised to press onward.

While there have been several changes to our monthly publication, many things remain unchanged. Perhaps most importantly is the advertising funds we receive from our commercial members, without which, "*On Course*" could not exist. The "Midwest" truly appreciates your continued support. In time we hope to offer expanded advertising options and increased magazine circulation, both of which should give you more for your advertising dollar. As you have noticed, we are now offering "four color" advertising option on the back cover. Additional commitment, to utilize this option, will allow us to increase the number of color pages. Please consider it and contact us if you are interested. We want to hear your comments, concerns and suggestions regarding our advertisement procedures and policies. Please let us know.

With the arrival of the New Year many of us will soon be turning our focus to Orlando, Florida, where the 1996 GCSAA International Turfgrass Conference promises, once again, to provide unprecedented educational and entertainment offerings. With the myriad of activities available there is surely something for everyone. One of the highlights will be the Annual Election of Officers where "one of our own", Bruce R. Williams, CGCS, is slated for GCSAA President. Bruce has devoted significant time and energy over the past several years, as both Director and most recently Vice President, and GCSAA and our profession alike, has been elevated because of this. The MAGCS proudly supports Bruce and looks forward to his dedication and leadership as GCSAA President, in the new year.

The MAGCS will again be hosting a Hospitality Suite during Conference week. A change this year will be the number of nights of operation. It will be held two nights instead of three, as in previous years. The Board of Directors felt that with all of the peripheral activities available in Orlando, with many opportunities to attend a number of other corporation hospitality events, and in an effort to control costs, the prudent action would be to limit our hospitality suite to two nights. We plan to utilize the funds received from the "Golden Tee Club" contributors, plus the usual amount annually budgeted from our operating budget as in previous years. Hosting two nights of hospitality with the same funding as we have used for three nights should provide us the opportunity to expand food and beverage selections and quantities. This will likely be a well attended event as many of our members will combine a vacation with their families into their trip to Florida. I look forward to it and hope to see many of you there. Let us all remember to thank and support, with our business, those whom so generously contribute to the "Golden Tee Club" program, for they make it possible for all to enjoy.

See you in Orlando... Or better, join us for a relaxing, enjoyable, and educational meeting on January 23, at Arrowhead Golf Club in Wheaton.

Best Wishes for a Happy, Healthy, and "Hole in One" Year!!!

Donald A. Cross, CGCS,  
President, MAGCS



# Golf Course Superintendent's First Amendment Rights

Until recently, golf course superintendents were taxed by compaction problems, dry spots and poor aeration. But this situation has been changed with the introduction of GREENSCHOICE®—*The First Amendment*. And today, golf course superintendents are proud to proclaim their First Amendment Rights.

1. *The right to free speech when employees fail to water and cut the greens.*
2. *The right to bear arms after someone turns off the timed sprinkler system on the hottest day of August.*
3. *The right to immunity after you severely injure that someone.*
4. *The right to an attorney when the sprinkler system failure is blamed on you.*
5. *The right to a nervous breakdown after it rains every day of the club tournament.*
6. *The right to free counseling after golfers destroy your immaculate greens.*
7. *The right to at least one day off a month.*
8. *The right to amend your greens with GREENSCHOICE, The First Amendment.*
9. *The right to healthy, trouble-free greens.*
10. *The right to be acknowledged as the greens genius that you obviously are.*

You have the right to dramatically improve water and nutrient retention, and enjoy reduced compaction and improved aeration of greens when you aerate or topdress with GREENSCHOICE. For more information, call 800/829-0215 or contact your local E-3 Turf Products representative.



## Nels J. Johnson Tree Experts, Inc.

A Tradition — More Than 60 Years  
Of Complete, Dependable, Economical Tree Service  
For Private Estates, Municipalities, Schools, Industrial Areas,  
Parks and Golf Courses  
(708) 475-1877  
912 Pitner Ave., Evanston, IL 60202

Since 1930



# FOUNTAINS...

## A Beautiful Solution for Your Water Management Needs

- Improves Water Quality
- Reduces Ugly Algae Blooms
- Improves the Beauty of Your Course



Helping You Grow



**Single Source For Fountains  
Free Quote 1-800-347-4272**

PLUS...

**OVER 33 CONVENIENT ADDITIONAL  
LOCATIONS TO SHIP FROM!**

1481 Timber Drive Elgin, IL 60123 (708) 608-8686 Fax (708) 608-8690	4691 Hydraulic Road Rockford, IL 61109 (815) 874-0200 Fax (815) 874-0203	8421 West 191 St. Mokena, IL 60448 (815) 469-7575 Fax (815) 469-1661	5379 Walnut Ave. Downers Grove, IL 60515 (708) 515-8555 Fax (708) 515-1228	636 S. Wheeling Rd. Wheeling, IL 60090 (708) 541-0300 Fax (708) 541-0685
--	---	---	---	---

YES! Please give me a quote on a new fountain.

Name \_\_\_\_\_  
 Address \_\_\_\_\_  
 City \_\_\_\_\_ State \_\_\_\_\_ Zip \_\_\_\_\_  
 Phone \_\_\_\_\_

Please mail or fax form to:

5379 Walnut Ave. • Downers Grove, IL 60515  
(708) 515-8555 • Fax (708) 515-1228

# A Commitment to Quality Turf Care Products For You - The Turf Care Professional



## Your Tee Time Distributor Offers You:

- Greens and Fairway Fertilizers with Nutralene
- Quality Sulfur Coated Urea Fertilizer
- Combination Products
- Granular Insecticides
- Granular Fungicides

For additional product information, contact  
**Craig Filley 1 (800) 225-2639**



Lawn Fertilizer Group  
P.O. Box 119  
Maumee, Ohio 43537  
1 (800) 225-2639







# FULL SERVICE GROUND WATER SPECIALISTS



## Meadow Equipment Sales & Service, Inc.

Well Drilling Contractors / Pump Service  
27 W. 021 St. Charles Road  
Carol Stream, IL 60188

- Water Well Drilling
- Pump Sales and Service
- Water Well Sealing & Capping
- Complete Waterwell Systems
- Large Selection of Pumps  
Line Shaft / Submersible
- Well Rehab & Chlorinations
- Maintenance Programs
- 24 Hour Emergency Service

**Authorized Sales and Service for  
Leading Pump Manufacturers**

WHEATON: (708) 231-6250  
ST. CHARLES: (708) 584-6210  
BENSENVILLE: (708) 766-1906



*"Where Meadow Goes,  
the Water Flows"*

# PRESSURE WASHERS



250  
to  
2,000  
PSI

## NEW AND USED

## FREE DEMO

- SALES
- SERVICE
- PARTS
- CHEMICALS

# CALL TOLL FREE 1-800-666-3900

*The Cleaning Equipment Specialists Since 1976\**



**TIM LAYDEN**  
General Manager

708-893-0777 • FAX (708) 893-1045

1-800-666-3900  
Sales Service Parts Rentals Chemicals  
25 S. Park Street • Roselle, Illinois 60172

# On The Cutting Edge with Bob Williams

## "On Course" Into the 21st Century

By Dave Blomquist

*Authors note: An important theme in this article was to be that Mr. Williams was being nominated for the prestigious USGA distinguished service award. At press time he was unaware of this honor and I didn't want to spoil the surprise. On December 12 however, it was announced that he will in fact receive the award at the GCSAA Conference in Orlando, thus joining a virtual list of "who's who" in the profession of golf turf maintenance.*

Welcome to "On Course" - the official publication of the MAGCS. As the profession of "Greenkeeping" has evolved, so has our publication. For 50 years it was known as "The Bull Sheet", which had humble beginnings as a simple one or two page mimeographed sheet with limited advertising. In 1951, the cover became two tone with a photo of O.J. Noer - the guru of turf in those days. Since 1983 Fred Opperman has served as our Editor. He is the 11th person to hold that position and throughout the years each has added their own twist as "The Bull Sheet" had grown into a 30+ page forum for information dissemination ranging from the latest university research to news around town.

Mr. Robert "Bob" Williams is featured in this historic issue for several reasons. First, his contribution to our profession cannot be easily measured as he has been influential in forming the very fiber of what is now our National Association (more on this later). Closer to home, it was Bob along with Norm Johnson from LaGrange C.C., Ray Gerber from Glen Oak C.C. (both along with Bob would go on to serve as

*"The Bull Sheet" had grown into a 30+ page forum for information dissemination ranging from the latest university research to news around town.*

President of the GCSAA), and Paul Burdett, father of Jim and a pioneer in the turf supply field, who came up with the idea of putting together a monthly newsletter for area Superintendents. They needed a name and while pondering this dilemma Bob referred to a news bulletin he worked on while serving in the armed forces in World War II. Bob reminisced, "When this thing came up in 1947 or '48, that name came back to me, and I threw it out on the table and the guys said - that's it!"

"The Bull Sheet" was born and it was an instant success. Through its proud history there has been sentiment to change that title, however it has endured. Although it was appropriate for the time, Bob never thought it would remain for 5 decades. He reflects, "as the industry progressed, I was one of the first to feel that "The Bull Sheet" was not altogether appropriate, and I was thinking that, well some day the boys will change it anyways".

Suggested Newsletter Name(s):  
"ON COURSE"  
"OF COURSE"  
"MIDWEST GREENKEEPING"  
"GREENS TECHNOLOGY"

Other ideas or suggestions you would like implemented in the monthly newsletter:  
"GOLF GREEN"  
"GOLF SUPERINTENDING"  
"COURSE MANAGEMENT"  
"GOLF AGRONOMICS"  
"GREENKEEPING UPDATE"  
"PBR FOR THE COURSE"

Print your name: Bob Williams

PLEASE RETURN THIS BY JULY 30!



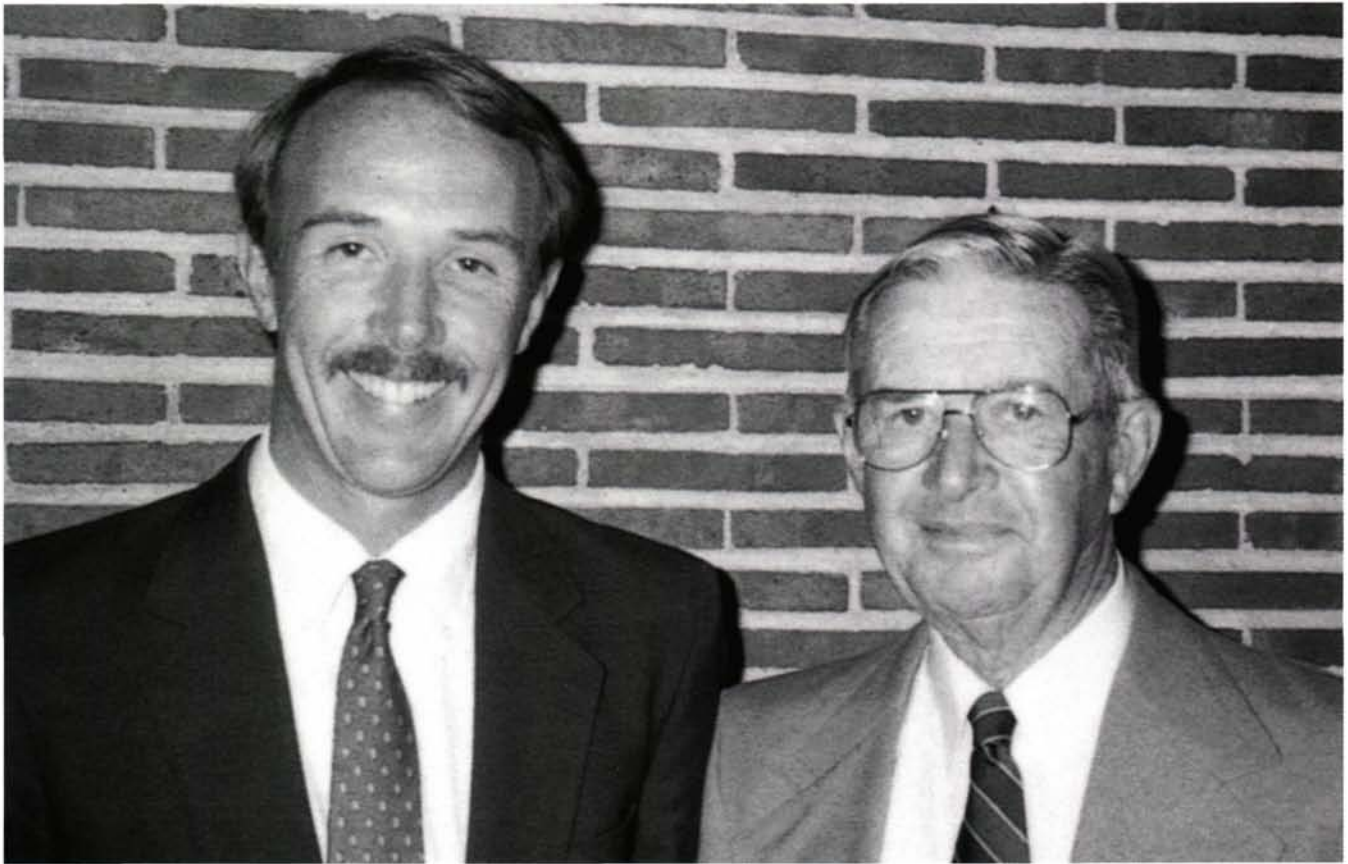

*"Like father, like son" Bob with son, Bruce, at a MAGCS meeting a few years ago.*

This past summer the Editorial Committee met to discuss ways to arrive at a new name. After agreeing that the membership should have input, mailings were sent out and over 200 ideas came from 75 returned cards. The committee selected the best examples and performed a blind vote. Lo and behold, a suggestion by a retired Superintendent stood out - "*On Course*" was the unanimous choice by both the Editorial Committee and the Board of Directors. Ironically, Bob Williams provided that suggestion!

### **Bob and the MAGCS — A Lifelong Link**

Bob Williams has enjoyed a career in golf turf management that has spanned six decades! From his first job on his parents' course in Wauconda, IL at age 12, through his 32 years at Beverly C.C. and Bob O'Link G.C., and on through 14 years as a consultant, he has consistently demonstrated the ability to

adapt to the challenges faced every day of his career.

If there is a theme to Bob's career, it would be "adaptation is the key to achievement". Sometime that is not so easy. If the daily weather fluctuations aren't enough, environmental regulations, golfer expectations, equipment limitations, and public perception have forced Bob to get creative with his management practices.

These are but a few examples of his ingenuity and pioneer spirit:

- When experimenting with a Bentgrass nursery for crabgrass control at Beverly C.C., he discovered that Phenyl Mercury also controlled Dollar Spot. This discovery heralded a new beginning for fairway maintenance that was unheard of at that time. Previous to that point, Dollar Spot was left untreated in fairways and Bob was one of the first to control the fun-

gus. He had already developed what became known as "the Bob Williams boom" which he used for applying a new product which had just come to market - 2,4-D. Bob was able to spray the rough, particularly around trees for dandelions, and upon discovering a control for dollar spot, he was anxious to try it on the fairways. "I got this idea that if I put this thing on the fairways," he reflects, "well you'd only have to make about 4 passes and you could get the whole fairway covered."

The control of Dollar Spot on fairways was a significant advancement which proved so during the 1960 season. "All the courses were much like they were this past season; they were devastated," he says, "I was probably the only course in the Chicago area that sprayed fairways and I was probably the only course in Chicago that had any fairways left!" Another irony comes to



light as one of today's Superintendents' nemesis was influential in gaining national notoriety for Bob - Paul Harvey was boastful of Bob's Fairways, so much so that he devoted a radio segment to Bob O'Link's great fairways. As far as Bob remembers, he said nothing about the avian population.

Some other achievements

- Bob Designed and published plans for customized tee benches made of Redwood.
- Co-designed and installed one of the early classic examples of a customized automatic irrigation system for Bob O'Link.
- Originated and published the first contract form for Superintendents titled "A Letter of Agreement". It is currently used in GCSAA and USGA educational publications.

### **Bringing the GCSAA to the Forefront**

Bob was elected to the Board of the GCSAA in 1953 and at the 1958 meeting in Washington D.C., he was elected President. The National Association would not be what it is today if it wasn't for Bob's foresight. He spearheaded a movement to reorganize the headquarters' operations. Dr. Gene Nutter was employed as the Executive Director and the office was moved to Jacksonville Beach, Florida. As part of the reorganization, Bob developed their first "Table of Organization", along with the first written "Standard Operating Procedure", for Committees and Committee Chairmen.

In 1959, through his personal contact with Herb Graffis, then Vice President of The National golf Fund, the GCSAA received its first grant of funds from that group, and

has continued to receive funds (over \$500,000 to date) which have been channeled into student scholarships and turf research.

The GCSAA is better today because of his hard work and dedication. The Williams legacy continues in the person of his son Bruce, who followed his fathers footsteps at Bob O'Link, and is about to assume the role of President of our National Association.

---

*If there is a theme to Bob's career, it would be "adaptation is the key to achievement".*

---

### **Fighting Indifferent attitudes**

Clearly, Bob Williams typified the attitude of striving to better oneself and he wasn't afraid to step out to do so. Over 60 students and apprentice Superintendents have worked under Bob's tutelage. There was a time when an aspiring college educated individual had a hard time finding work as many Superintendents were reluctant to take these qualified men. Bob went against the flow, in fact he felt it was a win win situation for all involved, "it was a tremendous opportunity to help the students, to help the Superintendent, to help the club and to help me as a Superintendent."

### **Its Us versus the World**

Sometimes a Golf Course Superintendent has the feeling that it's him or her against the world. Bob has tirelessly led the drive to elevate the position of Golf Course Superintendent to the status of "Clubhouse" Manager or Golf Pro. He debated the General Manager concept with the then past president of the CMAA at an open forum being conducted at the New Orleans conference while he was the immediate past president of the GCSAA. "The Superintendent is the only staff member who daily makes decisions that will affect each player... he is the one who makes the important decisions about your club, therefore he should be paid accordingly," he stated.

Rest assured, if Bob Williams as well as many other Superintendents hadn't fought the good fight 30 years ago, our current salary structure would not be what it is today. In his consulting with clubs, he extols the virtue of hiring the right man for the job and paying him appropriately. "...you can't afford not to hire the best man available," Today, we are enjoying the fruits of Bob's labors as many Chicago area clubs have revised their compensation structure to attract quality Superintendents and more importantly, we are finally being considered as the top management professional on staff.

When it comes to leading the way, Bob Williams wrote the book. "Its important to remember that any time you're a little progressive and stick your head over the multitude, there are going to be people throwing stones at you - expect that." Each member of the MAGCS would be a better person both personally and professionally should they remember these words of wisdom coming from a man who has, even in retirement been "on the cutting edge."



**GCSAA's 67th  
International Golf Course  
Conference and Show**

February 5-11, 1996

**GCSAA Seminars  
Coming Soon  
To Your Area**

**Reel Grinding and Turf Equipment  
Maintenance Scheduling**  
March 12, 1996  
Galena, Illinois  
(Code # 922)

**Small Engine Maintenance and Repair**  
March 19, 1996  
Woodridge, Illinois  
(Code #925) **NEW!**

**Negotiating**  
March 21, 1996  
Springfield, Illinois  
(Code # 858)

**Wildlife Management and Habitat  
Conservation**  
March 22, 1996  
Springfield, Illinois  
(Code # 859)

**Calibration and Safety of Pesticide Application  
Equipment**  
March 26, 1996  
East Alton, Illinois  
(Code # 926)



**Register Today!  
Call 800/472-7878**

For a more detailed description of seminars, with dates and registration forms, please refer to your GCSAA Professional Development Catalog 1995-96. You may also reference your monthly issue of *Golf Course Management*.

Watch your mail for reminder post-cards highlighting seminars in your area!

***PRIMED SEED***

***Creeping Bentgrass and Kentucky Bluegrass***

- Quicker germination at higher or lower temperatures
- A more even stand of grass
- Reduced water usage during establishment
- Leads to increased seedling vigor to help compete with weeds
- Bluegrasses germinate almost as quickly as ryegrasses
- Cost competitive

***Order NOW for delivery in  
early March 1995***

FOR INFORMATION, CALL:

**Arthur Clesen, Inc.**



543 Diens Drive • Wheeling, IL 60090 • (847) 537-2177 • FAX (847) 537-2210



**RAIN BIRD**  
Keeping the golf world greener.™

# MAXILINK FREEDOM

---

## 100% WIRELESS OPERATION



**1-800-373-4120**

Addison • East Peoria • Rock Island

### MAXILINK (Maxi Wireless)

Upgrade your current irrigation management system without the ugly mess and hassle of open trenches

### FREEDOM

Put the power of central control in your hand.

*Retrofits to  
any Maxi  
central  
control  
system*



FREEDOM  
HANDHELD  
SHOWN



## Supplying the Chicagoland area with excellent service and technical expertise for over 27 years...

*We deliver...*



- Aquatic Products
- Block Retaining Wall
- Bulk Fertilizer
- Drain Tile
- Fertilizers
- Geotextile Fabrics
- Grass Seed
- Herbicides
- Hose
- Insecticides
- Irrigation Parts
- Marking Paint
- Specialized Pesticides
- Spreaders
- Spray Equipment
- Tee and Green Equipment
- Terra Shield Green Cover
- Tree Fertilizer

2N 255 County Farm Road, West Chicago, IL 60185

**708-668-5537**