

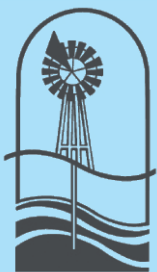

# HOME\*A\*SYST

Home Assessment System

## Home\*A\*Syst Home Assessment Guide



Michigan  
Groundwater  
Stewardship  
Program

MICHIGAN STATE  
UNIVERSITY  
EXTENSION

Extension Bulletin WQ-51  
Revised May 2008





### What's inside?

Home\*A\*Syst chapters cover essential topics that every homeowner or resident should understand. Each chapter contains key points, along with tables of assessment questions, to help you understand which risks apply to your situation.

- Chapter 1: Site Assessment: Protecting Water Quality around Your Home ..... 3**
- Chapter 2: Managing Household Trash: Preventing Waste, Reusing, Recycling and Composting.....13**
- Chapter 3: Managing Hazardous Household Products.....25**
- Chapter 4: Lead in and around the Home: Identifying and Managing its Sources .....37**
- Chapter 5: Indoor Air Quality: Reducing Health Risks and Improving the Air You Breathe .....49**
- Chapter 6: Energy Savings for Your Home .....63**
- Chapter 7: Managing Stormwater around Your Home.....75**
- Chapter 8: Conserving Water around Your Home .....83**
- Chapter 9: Caring for the Yard and Garden.....93**
- Chapter 10: Protecting Your Drinking Water Well .....107**
- Chapter 11: Managing Household Wastewater: Septic Systems and Other Treatment Methods .....117**
- Chapter 12: Managing Liquid Fuels Safely: Gasoline, Heating Oil, Diesel and Other Fuels.....129**

### What is Home\*A\*Syst?

Home\*A\*Syst is a confidential self-assessment program you can use to evaluate your home and property for pollution and health risks. In every home, potential pollution sources exist that can affect the health of your family, your community or the environment. Drinking water, for example, can be affected by many contaminant sources: poorly maintained septic or sewage systems, leaky fuel tanks, fertilizers, pesticides and hazardous household products.

### Getting started

You can do Home\*A\*Syst's risk assessment exercises one at a time or all together—it's up to you. The main idea is to take the time to find out if there are risks to your family's health or pollution threats to your environment. Then, where feasible, take action to reduce those risks and prevent problems.

This publication helps you accomplish three important objectives:

1. Identify environmental risks, concerns or problems in or near the home.
2. Learn how to better manage your home and property and how to find further information.
3. Take preventive actions to safeguard your health and the environment.

### It's up to you!

These Home\*A\*Syst chapters are not difficult to complete, and the results can benefit you and your family. For example, working with your children can be a great educational experience for everyone. And actions you take to eliminate risks may improve your property's resale value. If you value a clean environment and healthy surroundings, then by using Home\*A\*Syst—and making changes—you can invest in your family's future and invest in your community.

## Why is it important to take action?

Simply identifying risks does not prevent problems. Consider the following reasons for making voluntary improvements, particularly for responding to medium and high risks identified in your home.

### ◆ To safeguard your health!

You probably spend a lot of time in your home. Dangers in the water you drink or from hazardous chemicals in your home must be eliminated quickly and effectively.

### ◆ To prevent contaminating water supplies and other natural resources!

Protecting groundwater and surface water quality is essential to you and your neighbors and to others downstream. This is important whether your drinking water comes from a private well or a municipal system. Everything is connected, so what you do affects others.

### ◆ To protect your financial investment!

Your home is often your most valuable investment. Knowing about potential risks or problems can help prevent costly cleanups, repairs and legal troubles. And it pays not only to take care of your own property but also to make sure others around you are using good management practices. Property values and tax burdens can be affected by pollution problems on your property and in your neighborhood or city. In addition, taking steps to cut your use of water or other resources can save you money.

## Residential Environmental Assurance Program

Do you want to be a **certified environmentally responsible neighbor** and be in the forefront of leadership on residential environmental practices in your community?

Do you want everyone to know the effort you have made to make your home and community environmentally safe?

The Michigan Groundwater Stewardship Program and its partners encourage you to become certified through the **Residential Environmental Assurance Program (REAP)**.

**REAP** the benefits for your family and neighborhood in making changes to protect your health, home, water and much more. The assessments in each chapter indicate what is needed for certification.



This chapter will provide an aerial view of your homesite and help you to identify activities that pose risks to water resources. Completing the chapter will provide information you can use throughout the Home\*A\*Syst series. This site assessment covers two areas:

### 1. Physical characteristics of your homesite

- ◆ Soil type and depth
- ◆ Depth to bedrock
- ◆ Depth to water table
- ◆ Location of wetlands, streams or lakes
- ◆ Your watershed

### 2. A site map of your home

You will create a map of your homestead, with buildings, roads, possible pollution sources, and other human and natural features, to help you identify potential trouble.



Michigan  
Groundwater  
Stewardship  
Program

## Chapter 1. Site Assessment: Protecting Water Quality around Your Home

### Why should I learn about my homesite’s physical characteristics and how I manage my home?

What you do in and around your home can affect water quality both below the ground and in nearby lakes, streams, wetlands or coastal ponds. This chapter will help you identify some important physical characteristics of your homesite, such as soils, geology, depth to groundwater and nearness to surface water. It also invites you to draw a simple “aerial view” map of your homesite. Your completed map will show the locations of important features and activities in and around your home that may pose risks to your health and the environment. Remember, this assessment is a starting point. It is meant to encourage you to complete all of the other Home\*A\*Syst chapters that relate to your homesite.

### What is a watershed?

The water from your faucet and in nearby lakes or streams is part of a much larger water system. Not everyone lives next to a pond or stream, but we all live in a **watershed** – the land area that contributes water to a specific surface water body, such as a pond, lake, wetland, river or bay. The landscape’s hills and valleys define the watershed or “catchment” area (Figure 1). It is like a bathtub. The watershed outlet – the mouth of a pond, lake or river – is the tub’s drain. The watershed boundary is the tub’s rim. A watershed’s drainage system consists of a network of rivers, streams, man-made channels and storm drains, wetlands and the underlying groundwater. Common activities – such as how you dispose of used motor oil or fertilize your lawn and garden – can affect water quality, even when you do these things far from any shore. Paying careful attention to how you manage activities in and around your home helps protect your watershed and the water you drink. It helps protect city as well as private wells. You can surf your watershed and obtain information about local watershed organizations by going to websites given at the end of this chapter. Some areas in Michigan have existing watershed activities. Go to [www.michigan.gov/deqwater](http://www.michigan.gov/deqwater) and select “surface water,” then “watersheds” for more information.

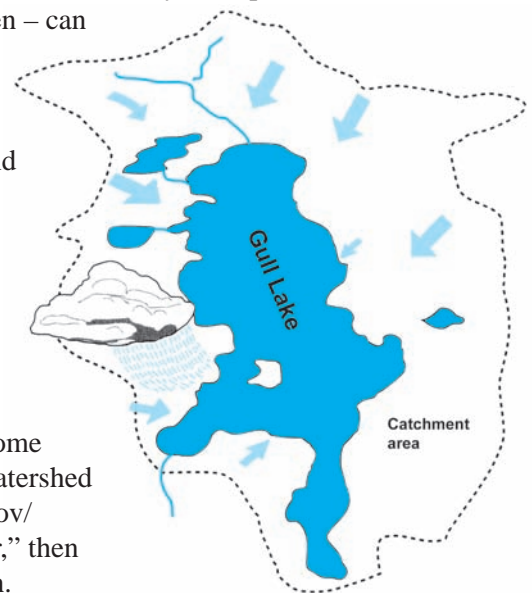

Figure 1: Watershed illustration, showing the catchment area (inside dotted lines), streams and receiving body of water.

## What influences the quality of your water?

Understanding the physical conditions of your residence and pinpointing the locations of potential contamination sources are important first steps in safeguarding your water supply. Physical characteristics such as soil type, depth to groundwater and nearness to surface water may speed up or delay a contaminant's effect on water quality. Activities that affect water quality include improper drinking water well construction and maintenance, pesticide/fertilizer use and storage, unsafe septic system maintenance, garbage disposal methods and animal waste storage (Figure 2).

Name your watershed:

(For help, see "Resources" at end of chapter.)

---

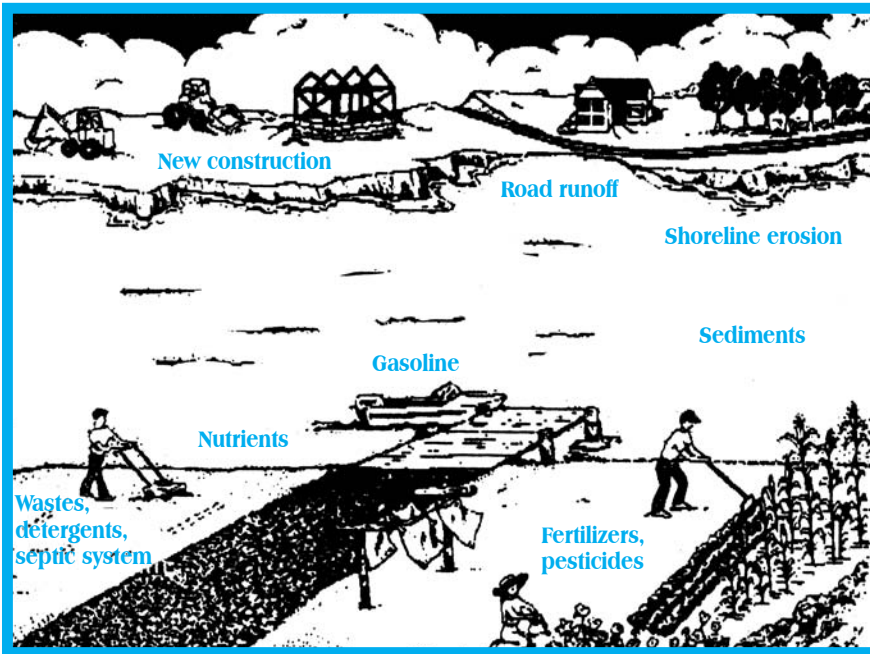

Figure 2: Some activities and physical conditions that can harm water quality.

## Part 1 – Physical Characteristics of Your Homesite

Every home comes with its own set of physical conditions. The information below will help you answer the questions in the assessment at the end of Part 1.

### How can soil type affect water quality?

Soil plays an important role in determining where contaminants go and how water moves. Nearly all soils are permeable – which means water and other fluids can percolate or move through them. Different types of soils have properties that permit water – and contaminants – to seep through or run off at varying rates. For example, chemicals applied to a lawn and wastes from a leaking septic tank can flow downward into groundwater or run across the land into surface water. Many household activities can also produce problems that go beyond property boundaries. Contaminants that enter groundwater through a neighbor's abandoned well may flow until they reach your well.

**Soil type:**

---

**What is your soil type?**

Soil is grouped into three basic types based on particle size: clay (small particles), silt/loam (medium particles) and sand/gravel (large particles). You can get a good idea about your soil type by rubbing a moistened sample between two fingers. Is it sticky like clay, gritty and crumbly like sand or somewhere in between? Consult the soil survey manual for your county conservation district or the soil survey website (see “Resources” at the end of this chapter) to learn more about your soil. Indicate your soil characteristics to the left.

**Soil depth:**

---

**What is your soil depth?**

The depth of soil influences risks to groundwater. Usually, the greater your soil depth, the farther water must seep down before reaching groundwater. Deep soils have a better chance of filtering or breaking down pollutants before they reach groundwater than shallow soils. Generally, soils that are less than 3 feet deep present the highest risks for groundwater contamination.

**Depth to bedrock:**

---

**How far down is bedrock and what type is it?**

Bedrock depth varies; it can be at the land’s surface, just below the surface or hundreds of feet deep. The depth of the soil and the type of rock influence pollution risks. Shale, granites and other dense types of rock make an effective barrier that blocks the downward movement of water and contaminants. Other rocks, such as limestone, can be highly permeable, allowing water to move freely. When bedrock is split or fractured, water can move through it unpredictably, spreading pollutants rapidly over long distances.

**Type of bedrock:**

---

**On your property, what are the risks to groundwater?**

**Groundwater** is the water below the surface of the earth that, from the water table down, saturates the spaces between soil particles or fills cracks in underlying bedrock. Soil particle size influences which pollutants are able to reach groundwater. Clay soils, which are made of tiny particles, slow the downward movement of water and in some cases can impede water movement completely. Sandy soils allow for rapid water movement, and silty soils occupy the midrange. Soils made of large particles pose the greatest risk because they let water seep downward readily. The ideal soil is a mix of midsize particles to allow infiltration and enough tiny particles, such as clay or organic matter, to slow water movement and filter pollutants.

**What is underground at your site?**

There are several ways to find out about soil depth, bedrock type and other features below the ground. Check your well drilling records (if you have them), ask a neighbor who has a well, call a local well driller, and/or call the local health department and ask for information on your well or neighboring well logs. You may also contact the Michigan Office of Geological Survey (517-241-1515), the U.S. Geological Survey (517-887-8903) or the local county conservation district.

### What are the risks to surface water?

Soil type can also affect surface water contamination. Clay soils, which are not very permeable, encourage surface water runoff. During a storm or flood or even when you water your lawn, this runoff can wash contaminants from the land's surface into nearby surface waters. Runoff in cities goes to storm drains and then to surface water.

Your yard slope (the incline from the horizontal) also is important. A steep slope increases the risk for surface erosion and runoff. Combined with soil type, it can have a large impact on the speed and amount of runoff. A steep, clay soil slope would have greater runoff risk than a similar sandy soil slope. A low-risk site would have a 0 percent (flat) to 4 percent slope (4-foot rise in 100-foot horizontal distance).

### How deep is the water table?

If you dig a hole, you will eventually reach soil saturated with water. The water table marks the boundary between the unsaturated soil (where the pore spaces between soil and rock contain air, plant roots, soil organisms and some water) and the saturated soil (where water fills all pore spaces) (Figure 3). In a wetland, the water table is just below the surface or at the surface. The water table fluctuates throughout the year but is usually highest in the wet months of spring and in late fall. In general, the closer the water table is to the land's surface, the easier the groundwater may be contaminated. A water table that is less than 10 feet from the surface usually presents a high risk for groundwater.

### How are groundwater and surface water interconnected?

Groundwater generally flows downhill, following the same path as surface water, and eventually discharges into rivers, lakes, springs and wetlands. If you keep impurities out of surface water but do not protect groundwater – or vice versa – contaminated waters may occur where you least expect.

List nearby lakes, streams and wetlands and distance to your property:

---

---

---

Depth to your water table: (Check with your local health department.)

---

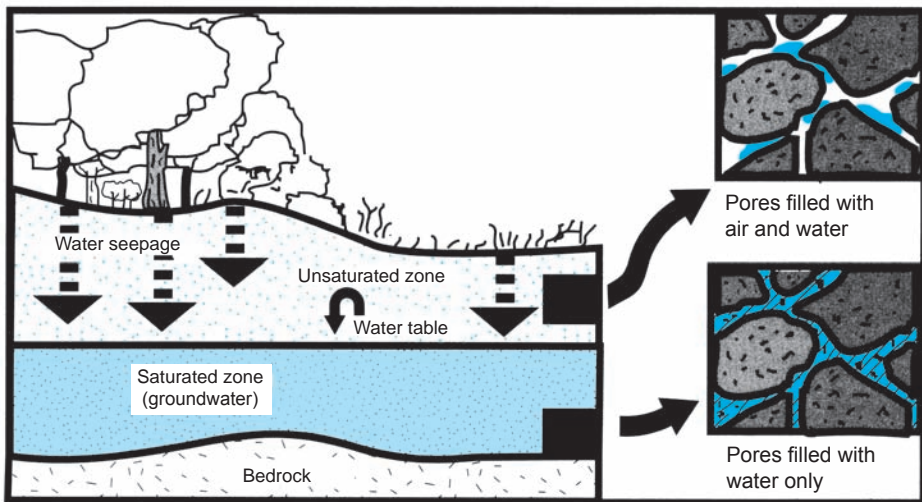

Figure 3: Groundwater, water seepage, saturated and unsaturated zones, and the water table.





## ✓ Assessment 1 – Homesite Characteristics: Identifying the Risks

For each characteristic (row), three choices are given that describe situations or activities that could lead to high, medium and low risks of groundwater contamination. For some questions, your well drilling records or local well drillers may be able to help. Some choices may not be exactly like your situation, so choose the response that best fits. Write your risk level (low, medium or high) in the column “Your risk.” Refer to Part 1 above if you need more information to complete the risk assessment.

	<b>Low risk/ recommended</b>	<b>Medium risk/ potential hazard</b>	<b>High risk/ unsafe situation</b>	<b>Your risk</b>
<b>Runoff risks to lakes, rivers, wetlands or other surface water due to soil type</b>	Sand/gravel (large particles).	Silt/loam (midsized particles).	Clay (very tiny particles).	
<b>Runoff risks to surface water due to slope</b>	Yard with 0-4% slope.	4-9% slope.	Greater than 9% slope.	
<b>Risk to groundwater due to soil type</b>	Clay (very tiny particles).	Silt/loam (midsize particles).	Sand/gravel (large particles).	
<b>Soil depth</b>	Deep (over 12 feet).	Moderate depth (3 to 12 feet).	Shallow (less than 3 feet).	
<b>Bedrock</b>	Solid, not permeable or fractured.	Solid limestone or sandstone, or fractured granite or shale.	Fractured limestone or sandstone.	
<b>Depth to water table</b>	More than 20 feet.	10 to 20 feet.	Less than 10 feet.	
<b>Nearness to surface water</b>	More than 100 feet.	25 to 100 feet.	Less than 25 feet.	

### Responding to risks

Do not depend solely on the physical characteristics of your soil, bedrock or other site features to protect water quality. You must take informed steps to prevent pollution. Make it your goal to consider the pollution risks identified above in all your activities. Although you can’t change your soil type or the depth to bedrock, you can take these factors into account when choosing home management practices to prevent environmental problems. Note especially the medium and high risks you identified. Keep them in mind as you complete the following map and work on other Home\*A\*Syst chapters.

## Part 2 – Making a Map of Your Homesite

### Why make a map?

Your property has some features you can change to minimize risks. Draw a map of your homesite, identifying areas where you can focus your efforts. This map will assist you in completing other Home\*A\*Syst assessments. And if you involve children as you make your map and conduct the assessment, you will help teach them the importance of having clean water.

The materials you need are readily available: measuring tape (optional), clipboard, pencil and the grid on the last page of this chapter. The map you create will be an aerial view – the way your property would look if you took a photo of it from the air (see Figure 4).

### Potential sources of contaminants

Several management practices and home-structure situations could result in major impacts on water quality. As you survey your property to make your map, be especially watchful for the following:

- ◆ Improperly located or poorly maintained septic system.
- ◆ Underground storage tank containing fuel oil, gasoline or other petroleum products.
- ◆ Improperly constructed well or an abandoned well.
- ◆ Stockpiled animal waste close to the well.
- ◆ Improper storage, use or disposal of yard and garden chemicals.
- ◆ Machine maintenance workshop near your well.

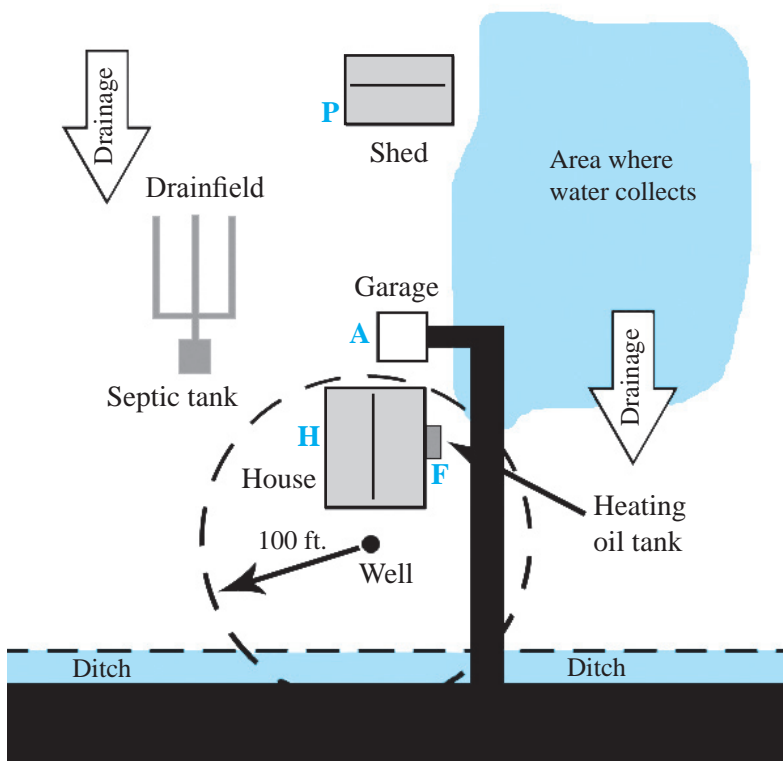

Figure 4: Example of a homesite map with surface water collection area, flow direction, fuel (F), automotive products (A), pesticides (P) and hazardous products (H) storage.

## Instructions: your homesite map

### Homesite features to include:

Property boundaries	Abandoned well	Pesticide/fertilizer storage
House and garage	Dry well	Compost pile
Outbuildings, sheds	French drains	Rain barrel
Animal pens and yards	Floor drains	Rain garden
Septic tank and drainfield	Vegetable garden	Trees
Ornamental ponds	Lawn area	Nearest surface water (lakes and streams)
Water wells	Other cultivated areas	Flower beds (non-veggie gardens)
Heating oil storage tank	Roads, driveways	
	Drainage ditches	
	Storm drains	

**Location codes.** On your map, note the areas where you store chemicals and other potential hazards by using letter codes. Make up your own code letters or symbols as needed. Examples:

F = Fuel tanks for gasoline or heating oil.

A = Automotive products such as motor oil, gasoline and antifreeze.

P = Pesticides (herbicides, insecticides, fungicides, etc.).

H = Hazardous products such as solvents.

**Other map-making ideas.** For larger view maps, add landscape and human-built features such as hills, rivers, lakes, ponds, roads, bridges, city wellhead protection area and runoff drainways. Draw arrows to indicate the direction of river and stream flow and stormwater runoff. Note potential sources of contamination beyond the boundaries of your property, such as farm fields, dumps and gas stations. Indicate seasonal changes at your homesite. For example, are there wet areas in the spring or fall? Such areas might indicate a high water table.

**Don't leave out things you cannot see.** Inquire about previous or current industrial or agricultural activities in the area. Old landfills and buried fuel tanks are just a few possibilities. Find out if any underground fuel tanks exist on neighboring properties. If tanks, septic systems or other potential sources of contaminants exist upgradient (that is, "upstream") from your water well, they could affect the safety of your groundwater.

### Putting it all together – and taking action

The final step is to put both pieces of your assessment together – the risk assessment itself and your homesite map – so you can identify potential problems on your property. If you have rated any items in the risk assessment as medium or high risk and have identified potential contamination sources in these areas, then you should be concerned. For example, you may have discovered that your heating oil tank is located in an area with a high water table or that you apply lawn or garden chemicals within 25 feet of a lake or stream. Perhaps your soil is sandy and your gasoline storage tank is close to your drinking water well. Maybe there is an old abandoned well on your property that isn't properly sealed. You will then want to investigate the options to lower your risks. To protect your family's health and the environment and to safeguard your financial investment, you will want to take steps to correct these problems.

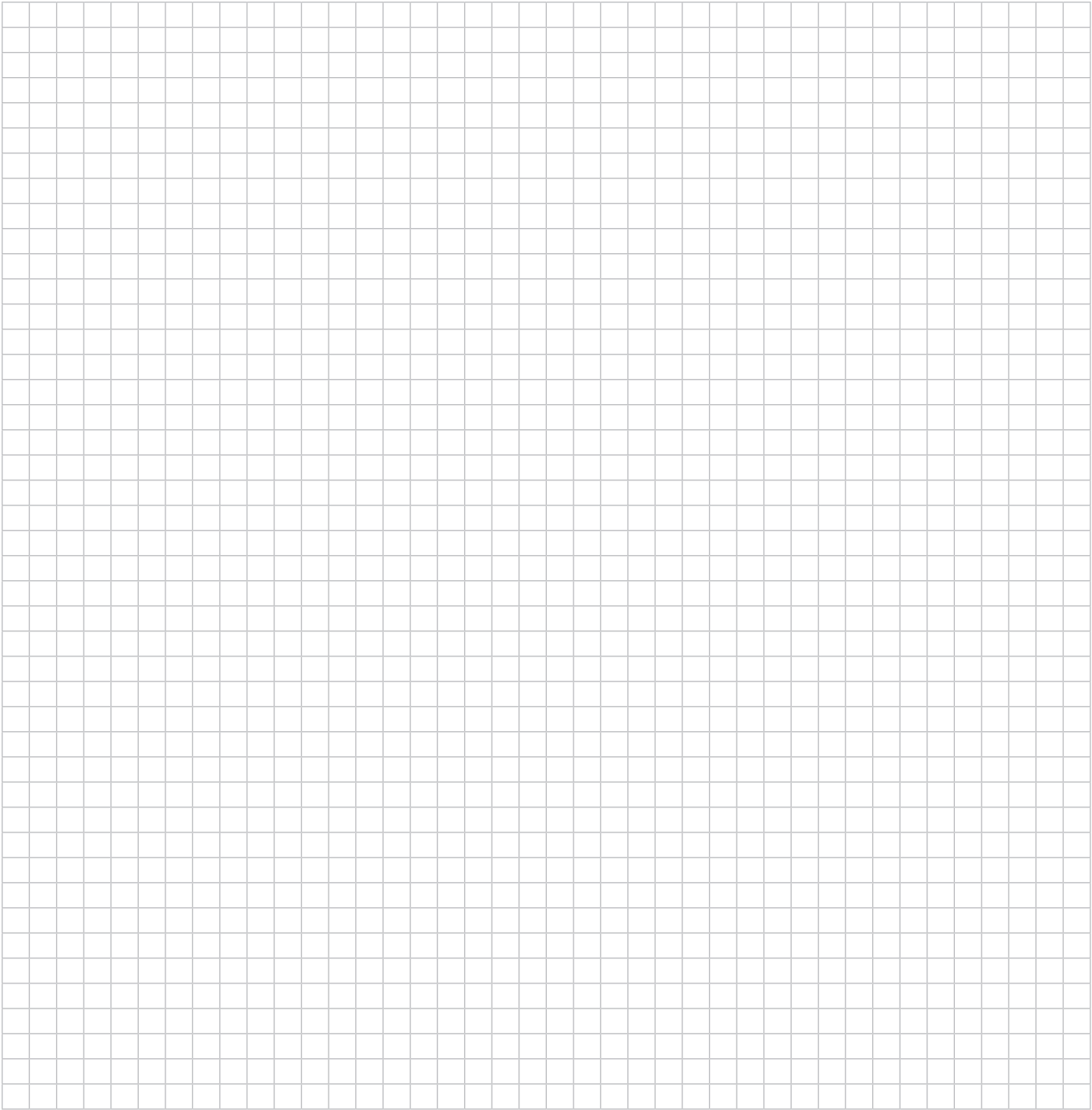

Blank graph sheet for drawing your homesite map

**For Residential Environmental Assurance Program (REAP) certification:**

- ◆ Complete all the blanks in the margins of this chapter regarding your soil, bedrock, distance to surface water and depth to water table.
- ◆ Complete a homesite map detailing features given on the previous page under *Instructions: your homesite map.*



## Resources

### Locating lakes, rivers and wetlands:

<http://gwmap.rsgis.msu.edu>

Select *Start the Viewer*. Place indicator at your homesite and zoom in on your part of the county. You will see lakes as blue areas and rivers as black lines. Go to *Visibility* and select *Groundwater Inventory* and then select *Wetlands*. You will see green outlined wetland areas. After this you may go back to *Visibility*, and under *Image Backdrops* click *Aerial* to view your homesite. To measure the distance from your home to the lake, river or wetland, you can use the *Measure* feature in the buttons at the top.

### Soil information:

<http://websoilsurvey.nrcs.usda.gov/app>

### Michigan water information:

<http://mi.water.usgs.gov/hydrosum.php>

### Watershed organizations:

[www.michigan.gov/deq](http://www.michigan.gov/deq)

Enter “Michigan Watershed Organizations” into search.

### Watersheds:

Surf your watershed: [www.epa.gov/surf](http://www.epa.gov/surf)

Watershed map: [www.michigan.gov](http://www.michigan.gov)

Enter “Michigan’s major watersheds” into search and open map.

Watershed map and other information: [www.iwr.msu.edu](http://www.iwr.msu.edu)

For map go to “Tools & Data, Watershed mapping,” then log in and select watershed site.

**How Home\*A\*Syst can help.** If you identify potentially hazardous or unsafe situations in your site assessment, what should you do? Refer to the chapters that relate to your home. There are 11 more chapters in the Home\*A\*Syst series. They deal with specific concerns. For example, the chapter on liquid fuels contains information on the safe management of gasoline, heating oil, diesel and other fuels. The chapter on drinking water wells will explain how to manage your private well water supply. These chapters will help you identify problems and develop an action plan for protecting groundwater, your family’s health and the local environment.

This chapter was written by Alyson McCann, Water Quality Program coordinator, University of Rhode Island Cooperative Extension, Kingston, R.I., and adapted for Michigan by Ruth Shaffer, Natural Resources Conservation Service, and Jim Bardenhagen and Roberta Dow, Michigan State University Extension. Updated in 2008.





**T**here are many ways to reduce the amount of household trash you produce and many alternatives to dispose of the waste you make. This chapter helps you examine your current waste disposal practices and how they may affect air and water quality on your property. It covers:

**1. Reducing the amount of trash you produce**

- ◆ Shopping to reduce waste (“enviro-shopping” and “recycling”)

**2. Creative methods to deal with wastes**

- ◆ Reusing
- ◆ Recycling
- ◆ Composting

**3. The hazards of waste disposal on your property**

- ◆ Alternatives to on-site dumping and burning

## Chapter 2. Managing Household Trash: Preventing Waste, Reusing, Recycling and Composting

### Why should you be concerned?

As the U.S. population increases, the amount of trash produced each year also increases. Not only are there more people, but each person is producing more waste than people did in the past. Studies estimate that in 2005, each person produced around 4.5 pounds of waste each day, compared with 2.7 pounds in 1960. Surveys also found that most consumers do not realize what is in their own trash. Many think they throw away more plastics—by weight—than they really do, or that disposable diapers are the major problem. Figure 1 shows what is really in the mountain of solid waste thrown away by Americans each year. What would you find if you examined unwanted wastes from *your* household over a year’s time?

#### How many words for trash?

What do you call the stuff you want to get rid of—trash, garbage, solid waste, recyclables, refuse or junk? Here’s how we define it for this assessment.

**Trash and waste** - two terms that refer to all items and materials that are no longer wanted.

**Reusables** - items that are used again by a different user or for a different purpose but not reprocessed. An example is a hand-me-down-jacket or a peanut butter jar used for storing nails.

**Recyclables** - materials such as glass, metal, plastic, paper, even refrigerators, that are processed back into raw materials and made into new products.

**Compostables or compost materials** - organic matter (primarily yard and food wastes) that decomposes and returns to the earth as nutrients and a soil conditioner.

**Garbage** - stuff that gets truly thrown away by being taken to a landfill or incinerated.



Michigan  
Groundwater  
Stewardship  
Program



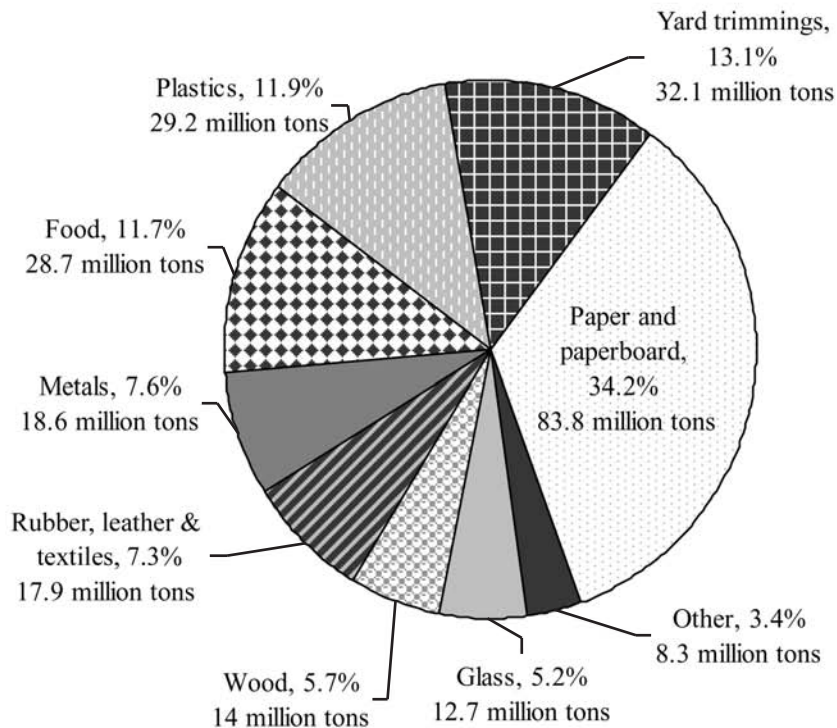

Figure 1: Annual amount of solid waste from U.S. households. EPA, 2005.

### The problem with waste

Landfills and incinerators are the destination of most of our trash. In Michigan, yard waste is not allowed in landfills or incinerators because it can be composted. A list of other wastes that cannot be landfilled can be found on the Department of Environmental Quality (DEQ) website (see “Resources” at the end of this chapter). Environmental laws have closed poorly managed dumps, improving the safety of remaining landfills and incinerators. Garbage has become a serious transportation, environmental and economic issue for consumers and municipalities. The good news is that these problems have caused Americans to look for new ways to deal with their trash. Producing less waste, reusing, recycling and composting not only save taxpayer dollars but protect air and water quality and the health of people and wildlife.





## Part 1 – Minimizing and Preventing Waste

If you don't produce trash, you won't need to get rid of it—it's that simple. But we all generate some trash, so we need to think about ways to make less. Part 1 helps you examine your potential for cutting the amount of waste you produce and for preventing some kinds of waste completely. At the end, fill out the assessment table to determine your waste potential, using the information below to help answer the questions.



Figure 2: Light bulb comparison. Compact fluorescent bulbs—even though they cost more—last 10 times longer than ordinary bulbs. In the long run, they cost much less to operate.

### Can you become a waste-conscious shopper?

You make purchasing decisions every day, and each purchase involves a certain amount of waste. Whether you're buying groceries, toys, furniture or appliances, your selections determine the type and volume of waste that must someday be discarded. But if you buy with the environment in mind—that is, if you use your purchasing power to minimize your impact on the environment—you will select products that produce a minimum of waste. **Precycling** and **enviro-shopping** are terms that refer to this kind of purchasing. The following questions are ones typically asked by an enviro-shopper before a purchase is made.

#### How much do you need?

Among other things, enviro-shopping means buying only what you need. A good price or a bulk package may tempt you to buy a larger amount of paint, food or household cleaner than you really need. But what may seem like a good deal when buying often ends up wasting money because the unused or spoiled product is eventually thrown away. Make sure you can use what you buy or know someone who can use the leftovers.

#### Are your purchases long-lasting and reusable?

In our throwaway society, it is sometimes hard to find good quality products at an affordable price. Although durable products may be more expensive, they are usually a better investment in the long run (Figure 2). Look for products that can be repaired when broken. Children's toys that are held together with screws, for example, often can be more easily taken apart and repaired than toys that are glued. Long-lasting products make good hand-me-downs, too. Products and materials that can be reused—passed along or used for other purposes—save money and conserve resources. If you have fabric scraps, for example, they can be sewn into attractive, reusable gift bags that can reduce your need to buy wrapping paper. In a world with increasing numbers of disposable and single-use products, it is a real challenge to avoid waste when shopping.

### How much trash do you make each day?

This project is for the truly adventurous: carry a large plastic bag for 1 to 3 days and put all your daily trash inside. Pick a typical week, and don't change your buying habits. At the end of the experiment, weigh the bag. If you carried your bag for 3 days, divide the total weight by 3 to get the daily amount. You might want to keep wet wastes in plastic zip-top bags so things don't get too messy. Then analyze your trash. How much of the material is paper? How much is recyclable? How much is hazardous? How much could have been avoided? How many pounds of trash would you produce in a *year*?

### Is the package recyclable?

Many product containers and packaging materials are potentially recyclable, such as cardboard boxes, glass and many plastic bottles. To promote recycling, many manufacturers use the international chasing arrows “recyclable material” symbol (see Figure 3). But be careful—the symbol only means the product is made from materials that are *suitable* for recycling *if* your local recycling program will take them. If it cannot be recycled locally, then the product package is not truly recyclable, at least not where you live. The list of materials that your local program will accept changes over time, so you will need to keep up-to-date. If you can't recycle locally, you might be able to take some of your recyclables to a neighboring community that will accept them. Much information can now be obtained online; see “Resources” at the end of this chapter.

### Is the product or its packaging made from recycled materials?

A surprising variety of products are made from recycled material—everything from carpets to salad dressing bottles. Once materials are recycled, they will be made into new products or packaging only if there is a market for them. As a consumer, you can use your buying power to support and encourage markets for recycled-material products. This is sometimes called “closing the loop”—when you recycle and buy recycled. This ensures that materials are cycled again and again. Each year, for example, billions of aluminum beverage cans are melted down and made into new cans. On product packaging, look for the words “made from recycled materials” and especially for “made from postconsumer recycled materials.” Postconsumer means that all or part of the packaging is made from materials that have been recycled by consumers in community recycling programs. Instead of words, some packaging materials (such as corrugated cardboard) use the chasing arrows symbol in solid black or in a black background (see Figure 3). This means that packages or products are made entirely or predominantly from recycled materials.

### Do I buy products with the least amount of packaging?

In America, we produce more trash per person than people anywhere else in the world. About a third of the paper, plastic, glass, cardboard and metal we throw away comes from packaging. Packaging serves many useful purposes—such as preventing food spoilage and keeping products clean—but much is unnecessary, wastes natural resources and soon after purchase ends up as garbage. Good enviro-shopping means choosing products having the least amount of wrapping (as long as safety is assured). Buying bulk foods and items that you know will be used in a timely manner and selecting concentrated packaged products are examples of ways to minimize waste from packaging.

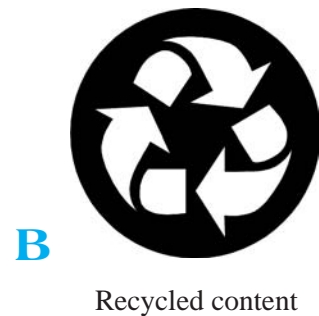

Figure 3: Recycling symbols.

A. Recyclable material symbol – container or package is *potentially* recyclable.

B. Recycled content symbol – container made from recycled materials.



If your packaging selections are limited, tell the store manager what you want and write or call the product manufacturer about your community’s solid waste situation and your preference for minimally packaged products.

## ✓ Assessment 1 – Minimizing and Preventing Waste

Use this assessment to identify areas where you can minimize waste. Write your waste potential level (low, medium or high) in the column labeled “Your waste potential.” Although some choices may not correspond exactly to your situation, choose the response that best fits. Refer to the information above to help you answer the questions.

	<b>Low waste potential</b>	<b>Medium waste potential</b>	<b>High waste potential</b>	<b>Your waste potential</b>
<b>Packaging purchased</b>	I usually select packaging that minimizes waste.	I sometimes consider packaging when selecting products.	I never consider packaging that minimizes waste.	
<b>Ability to recycle packaging</b>	I regularly purchase containers/packaging that can be recycled locally.	I sometimes consider whether packaging is recyclable when making purchases.	I never consider whether packaging is recyclable before buying.	
<b>Quantities purchased</b>	I purchase only what is needed and avoid accumulating unused products.	I sometimes buy more product than I can use.	I often purchase more product than I can use.	
<b>Products purchased</b>	I try to purchase items made from recycled content.	I rarely consider products made from recycled content.	I do not seek products made from recycled content.	
<b>Product durability and potential for reuse</b>	Products are selected on the basis of durability, ease of repair and potential for reuse.	I sometimes select products on the basis of durability, ease of repair and reuse.	I never consider durability, ease of repair or reuse.	

### Responding to your waste potential

Your goal is to reduce the amount of waste you produce—especially waste that ends up in a landfill or incinerator. Turn to the Action Checklist at the end of this chapter to record the high and medium waste potentials you identified in the assessment above. Use the ideas in Part 1 to help you become an enviro-shopper.

## Part 2 – Reusing, Recycling and Composting

Once you make waste, it has to go somewhere. Part 2 reviews three ways to keep materials out of the landfill or incinerator. For each item of trash, there are three questions to ask:

### 1. Is it reusable?

Reuse should be your first objective because it typically causes the least amount of environmental impact. By taking canvas or net shopping bags to the store or mall, you will be avoiding bringing paper or plastic bags home. Reusable bags not only reduce waste but can be cleaned and are stronger than disposable bags.

Sharing old clothes and used furniture is a common form of reuse. If you can't share with friends or family, try to donate usable items to local charities. Holding a neighborhood yard sale is a good way to eliminate unwanted possessions *and* make a little money. You can usually find uses for more materials than you realize. Give your packaging foam "peanuts" to a local gift shop, for example, or see if neighbors can use your excess paint, lumber or empty plastic pails. Consider donating or selling at a recycle store, or try listing available materials on a postcard and posting it on a local community bulletin board. You might find success posting on the Web using one of the sale sites. Remember the expression "One person's junk is another's treasure." Often reuse is limited only by the imagination.

### 2. Is it recyclable?

Even though recycling is a good idea, it still requires the input of energy and other resources, and it produces some waste and pollution. For example, aluminum beverage containers can be recycled into new cans. They must be collected and returned to the factory, where they are melted and formed into new cans. The new cans are then trucked to a beverage company to be filled and taken to stores. An aluminum can makes a complete recycling circle in as little as 60 days (*Earth911.org*). A recycling success story!

Studies have shown that more than half of all household wastes are recyclable. Remember to keep current about what your local recycling program will accept. Find your local program using the clickable map at [www.michigan.gov/deqreswastecontacts](http://www.michigan.gov/deqreswastecontacts). Plastic milk jugs, for example, are usually recyclable, but wax-coated paper milk cartons can be recycled in only a few areas. A growing number of communities require recycling by law. You should not limit recycling to typical grocery store-purchased materials such as aluminum cans, cardboard, glass bottles and cans. Local scrap dealers or industrial salvage yards may want your broken appliances, junk vehicles, wood wastes, other metals, doors, windows and so on. A number of items such as motor oil and car batteries are banned from disposal in Michigan. Local landfills may have rules that ban other items as well. For more information, see the brochure "Talking Trash" by going to [www.michigan.gov/deq](http://www.michigan.gov/deq) and entering "banned landfill materials" in the search bar.



## Electronic waste

Computers, personal media players, cell phones, televisions, data assistants and other wonders of modern technology are filling our lives and our garbage cans. We rely on them daily to communicate, conduct business and educate, but what happens to this equipment when it's worn out or replaced by an updated version?

Many electronics contain hazardous materials, such as lead in solder, cadmium in circuit boards and mercury in batteries. Most older computer display screens and televisions contain cathode ray tubes (CRTs). CRTs contain leaded glass to protect the user from the x-rays inside the tubes. Lead is a hazardous material that can cause environmental and health damage if not managed safely. Lead in CRTs causes computers to be considered hazardous waste when disposed by regulated generators in Michigan. Residents are encouraged to recycle their electronic waste rather than have it end up in their local landfill or municipal solid waste incinerators with the potential of leaching or emitting lead and other heavy metals into the water or air.

Donating these items is becoming a common practice for extending the life of working electronics and reducing their placement in landfills. Before donating or recycling your old computer or other electronic device, make sure that the data on it is completely deleted. Reformatting the hard drive or deleting files may not be enough to protect you from identity theft. You need to *completely* destroy the data on your hard drive. In 2006, the U.S. EPA developed two fact sheets that provide information about donating electronic equipment and a list of free software you can use to delete information from your computer. See "Do The PC Thing for Consumers" at <http://www.epa.gov/epaoswer/osw/conserve/plugin/pdf/pcthing-con.pdf>.

Many Michigan communities have started electronic collections programs to deal with the growing e-waste. Check with your local community or waste hauler to see if and when a collection is available. Recycling options for Michigan residents are available at [www.michigan.gov/deq](http://www.michigan.gov/deq). Enter "electronic waste management" into the search bar. A national resource for recycling information is Earth911. By using your zip code, you can call or go online to find recycling opportunities near you. Call 1-800-CLEANUP or go to [www.Earth911.org](http://www.Earth911.org).

### 3. Can it be composted?

Yard and food wastes typically make up over 30 percent of the waste stream. The amount of yard and food wastes that your home generates depends on your eating and gardening habits, size of yard and region. Since 1995, Michigan has banned yard clippings (leaves, grass clippings, vegetable or other garden debris, shrubbery, tree trimmings) from disposal in Michigan solid waste landfills because of its large volume, high moisture content, and potential to contribute to landfill gas and groundwater problems. Composting—nature's recycling—is a much more effective way to handle organic waste. As an alternative to landfill disposal, many communities have established yard waste composting programs with convenient drop-off sites or curbside pickup.

**Composting** is a natural process that, with the help of microbes, earthworms and fungi, turns kitchen and yard wastes into a high-quality soil amendment. Many common materials can be composted in your own backyard: leaves, grass clippings, plant trimmings, straw, kitchen scraps (but not animal waste such as fat or bones), manure (except that of dogs, cats and other household pets) and even paper. The final product is dark brown, crumbly compost that has a clean, earthy scent. It can be spread on lawns or mixed with garden soil as an excellent soil amendment.

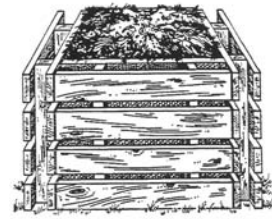
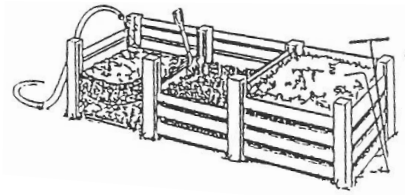

Many compact and efficient composting bins are on the market for home composting, or you can build your own (Figure 4). For more information on composting, see Chapter 9, “Caring for the Yard and Garden.”

## ✓ Assessment 2 – Reusing, Recycling and Composting

Figure 4: Examples of compost bins.

Use this assessment to identify preferred methods to keep waste out of the landfill. Write your waste potential level (low, medium or high) in the right-hand column. Although some choices may not correspond exactly to your situation, choose the response that best fits. Refer to the information above to help you answer the questions.

	Low waste potential	Medium waste potential	High waste potential	Your waste potential
<b>Reuse</b>	I reuse as many household wastes as possible.	I reuse when convenient.	I never reuse or recycle.	
<b>Waste recycling</b>	I always recycle all materials that centers accept.	I recycle materials when convenient.	I occasionally or never recycle materials.	
<b>Composting</b>	All yard wastes and kitchen scraps are composted at home or in a city program.	Some yard or kitchen wastes composted.	I never compost.	

**A boxed risk level** indicates level required for Residential Environmental Assurance Program certification.

### Responding to your waste potential

Your goal is to reduce waste or find the best alternatives for dealing with it. Turn to the Action Checklist at the end of this chapter to record the high and medium waste potentials you identified above. The information in Part 2 can help you plan changes.

## Part 3 – The Trouble with On-site Trash Disposal

Disposing of household trash by burning or dumping on private property is widely practiced but can pose threats to your health and the environment. Although many rural areas have used these disposal methods for decades, local and state laws are becoming more restrictive. At the end of this section, complete the table to determine your risks, and consider alternatives to on-site disposal methods.



Smoke from burning trash may contain:

- Arsenic
- Benzene and other solvents
- Cadmium
- Carbon monoxide
- Chromium
- Dioxin
- Formaldehyde
- Hydrochloric acid
- Lead
- Nitrogen oxide
- Polyaromatic hydrocarbons
- Sulfuric acid

### Do you burn your trash?

Many rural residents use burn barrels to get rid of many household wastes. When paper, plastics, printing inks, batteries and other common materials are burned, a noxious mix of chemicals is released into the air. Some of these—such as lead or mercury—can be hazardous to breathe. Eventually, most byproducts from burning are removed from the air by rain or snow and are deposited on land or water. Because of concerns about such releases of hazardous air pollutants, most states and localities have passed laws to restrict what you can burn. In some areas, especially urban and suburban settings, open burning has been banned.

The ash residue from burning also contains hazards, including heavy metals and other toxic substances. If this ash is dumped on your property, it can contaminate soil and water. To find out about burning restrictions that apply to your property, check with your local fire department or township office. More information about open burning can be found on the DEQ website at [www.michigan.gov/deq](http://www.michigan.gov/deq). Enter “open burning” in the search bar.

### Do you dump household trash on your land?

Trash dumped on your property is not only unsightly—it may contain harmful chemicals and disease-causing organisms that can leach out and contaminate groundwater or be spread by wind and rain. Discarded paint, for example, may contain lead or mercury. If not properly rinsed, pesticide containers will contain toxic residue, and used oil filters usually hold petroleum products and harmful metals. These pollutants can soak into the soil, pollute well water, and find their way into nearby lakes, streams or wetlands. If your trash contains hazardous substances—even in small quantities—they can cause problems.

Dumping, burying or burning trash on your property may also cause difficulties when you want to sell your property. Prospective buyers may require you to clean it up as part of the purchase offer.

#### Which wastes are hazardous?

By reading product labels, you can generally tell which ones have hazardous ingredients. Look for words such as DANGER, FLAMMABLE, POISON, FATAL IF SWALLOWED, CAUTION or WARNING. Use these products according to their label instructions. For more information on dealing with hazardous wastes, see Chapter 3, “Managing Hazardous Household Products.”

Especially for homes served by street drains and storm sewers, any solid or liquid wastes exposed to the weather—including pet wastes—can wash directly into lakes and streams. Storm sewers, remember, are rarely connected to wastewater treatment facilities. Some materials, such as foam peanuts and other plastic debris, can be transported by storm runoff to open water, where they may be mistaken for food and eaten by fish or birds, killing or injuring them. Another wildlife problem is caused by discarding tires that provide a haven for mosquitoes. Find your local household hazardous waste, recycling or composting program on the clickable map at [www.michigan.gov/deqreswastecontacts](http://www.michigan.gov/deqreswastecontacts) or call the Michigan DEQ Environmental Assistance Center at 1-800-662-9278 with questions about proper waste management.

### What do you do with unwanted medications?

Unwanted or unused medications can be a problem to the environment when poured down the drain, flushed down the toilet or thrown out. Medications have been found in groundwater and surface water and are a growing concern nationally and internationally. They should not be burned in the trash or disposed of on-site.

The following are suggestions for getting rid of medications:

- ◆ Check to see if the local pharmacy is taking back unwanted drugs. Some drugstores accept expired medications for disposal. Pharmacies cannot legally accept controlled substances from citizens.
- ◆ Find special collections for unused and expired drugs. Check with your household hazardous waste collection or recycling program coordinators to see if anything is available in your area. A list of contacts is at [www.deq.state.mi.us/documents/deq-ess-p2-recycle-countycontacts.pdf](http://www.deq.state.mi.us/documents/deq-ess-p2-recycle-countycontacts.pdf)
- ◆ If a collection program is not immediately available, follow the handling suggestions in the drug disposal section of the drug label/insert.

## ✓ Assessment 3 – Waste Disposal on Your Property

The following assessment can help you examine potential risks due to on-site waste disposal. Choose the statement that best fits your situation and put the appropriate risk level (low, medium or high) in the column labeled “Your risk.” Refer to the information above in Part 3 to help you respond.

### Responding to risks

Your goal is to reduce your risks. On the following Action Checklist, write your high and medium risks. Use the ideas in Part 3 to help plan actions you can take.





	<b>Low risk/ recommended</b>	<b>Medium risk/ potential hazard</b>	<b>High risk/ unsafe situation</b>	<b>Your risk</b>
<b>Burning trash</b>	No household trash is burned on site.	Paper and cardboard are burned. Burning done in approved container and guidelines followed.	Burning conducted. Burning guidelines ignored.	
<b>On-site dumping</b>	Only organic wastes (leaves, grass clippings, food, wood chips, etc.) are disposed of on your property.		Household trash and liquids, appliances, tires and other junk are discarded on site. Hazardous and other wastes are improperly discarded down sewer system, septic system or storm drains.	
<b>A boxed risk level</b> indicates level required for Residential Environmental Assurance Program certification.				

### ✓ Action Checklist

Go back over the assessments and look for all medium and high waste or high risk potentials you identified. Write them below. For each item listed, write down the improvements you plan to make. Use recommendations from this chapter and other resources to decide on actions you are likely to complete. A target date will keep you on schedule. You don't have to do everything at once, but try to eliminate the most serious problems as soon as you can. Often it helps to tackle the inexpensive actions first.

<b>Write all high and medium risks here.</b>	<b>What can you do to reduce the risk?</b>	<b>Target date for action:</b>
Example: Products purchased without considering if packaging is recyclable.	Find out about town recycling programs and try to buy products whose packaging can be recycled locally.	One week from today: May 15

## Resources

### Recycling, composting and waste disposal information

Contact your local health or sanitation department, recycling center or Michigan State University Extension office. Get the latest list of what is recyclable, how to identify it and how to prepare it for recycling. Ask for information on composting and other disposal alternatives.

List of local recycling programs:

Use clickable map at [www.michigan.gov/deqreswastecontacts](http://www.michigan.gov/deqreswastecontacts).

If no local recycling program:

[www.1800cleanup.org](http://www.1800cleanup.org) or call 1-800-CleanUp.

Electronic waste:

For information about industry-sponsored electronics recycling or disposal (computers, televisions, cell phones, etc.), contact the manufacturer. Many national electronics manufacturers and major retailers have sponsored collections and offer low- or no-cost recycling programs. Information can be found about these programs by searching their corporate websites or asking about them where you purchase your electronic products. You may also contact your local Goodwill store.

For more information about electronics recycling in Michigan:

[www.michigan.gov/deq](http://www.michigan.gov/deq) - Enter “electronic reuse and recycling” in the search bar.

Prescription drug disposal:

[www.deq.state.mi.us/documents/deq-ess-cau-rxbrochure.pdf](http://www.deq.state.mi.us/documents/deq-ess-cau-rxbrochure.pdf)

Wastes that cannot be landfilled:

[www.michigan.gov/deq-ess-p2tas-BannedLandfillMaterials.pdf](http://www.michigan.gov/deq-ess-p2tas-BannedLandfillMaterials.pdf)

### Local regulations on burning and dumping

Contact your local township, city or county government office to find out what waste management options are allowed and available. If you still have questions, contact the Michigan Department of Environmental Quality (DEQ) Environmental Assistance Center at 1-800-662-9278 or the DEQ Waste and Hazardous Materials Division or Air Quality Division District staff. You can find your district office by going to [www.michigan.gov/deq](http://www.michigan.gov/deq). Click “contact DEQ” at the top of the page, and then click the District Office Locations link.

### Books

**The green consumer supermarket guide.** 1991. Makower, J. Penguin Books, New York, N.Y. ISBN: 0140147756

**Rubbish! The archeology of garbage.** 2001. Rathje, W., and C. Murphy. University of Arizona Press, Tuscon, Ariz. ISBN: 9780816521432

This Home\*A\*Syst chapter does not cover all potential issues or risks related to solid waste management that could affect health or environmental quality. It is meant to serve as a starting point for identifying and addressing the most apparent risks. Other Home\*A\*Syst chapters on a variety of topics can help homeowners examine and address their most important environmental concerns.

This chapter was written collaboratively by Shirley Niemeyer, Extension specialist, University of Nebraska-Lincoln; Michael P. Vogel, solid waste specialist, Montana State University Extension Service at Bozeman, and Kathleen Parrott, Virginia Polytechnic Institute and State University at Blacksburg. It was adapted for Michigan by Terry Gibb, Roberta Dow and Jim Bardenhagen, Michigan State University Extension. Updated in 2008.



Some products may be harmful to your health and the environment when they're used improperly. This chapter will help you recognize and reduce your risks. It covers safe use of products from purchase to disposal.

**This chapter is divided into three parts:**

**1. Purchase and use**

- ◆ Product choice
- ◆ Amount purchased
- ◆ Safe use

**2. Safe storage**

- ◆ Child safety
- ◆ Containers and spill prevention
- ◆ Ventilation

**3. Disposal**

- ◆ What to do with leftovers



## Chapter 3. Managing Hazardous Household Products

### Why should I be concerned?

Some products used around the home can pose threats to your health or the environment if not used properly. Vapors from paint thinner and other solvents can be harmful to breathe. If dumped on the ground, products such as motor oil or pesticides may end up contaminating your drinking water or a nearby stream.

This chapter will help you make choices that will reduce risks to your family, your drinking water and the environment. It is up to you to use, reuse or dispose of these products safely. For each chemical or product, there are many questions to think about:

- ◆ Which product best meets my needs?
- ◆ Is there a less harmful product?
- ◆ What is the best way to store it?
- ◆ How can I use it safely?
- ◆ What should I do with leftovers?
- ◆ Is it safe to use around children?



### What does the word “hazardous” mean?

Hazardous products are used in many household jobs. Some are flammable and will catch fire easily. Others will irritate or burn your skin. Poisons (toxins) are often used around the house. Even products that you think are non-hazardous can cause problems if not used properly. These are explained below. It is good to know the difference between hazards to health and hazards to the environment.

**Household products that could be hazardous, if poorly managed:**

**Household cleaners**—ammonia, bleach, oven cleaner, drain opener, toilet cleaner.

**Building supplies**—treated lumber, sealants, some glues and cements, wood preservatives.

**Automobile products**—antifreeze, motor oil and fluids, cleaning solvents, lead-acid batteries, gasoline, mercury switches.

**Home maintenance products**—oil-based paints, mineral spirits, paint thinner, paint stripper, products that can remove tough grease or adhesives.

**Hobby and recreational supplies**—photo chemicals, marine paints, electronic equipment cleaners, pool chemicals, lighter fluid.

**Pesticides**—weed killers, rat and mouse poisons, insect sprays, fungicides, mothballs.

**Personal products**—hair sprays, fingernail polish, polish remover, hair remover, spray leather protector.

## Human health hazards

Chemicals contained in some of the products in your home can cause health problems, *especially if the user does not observe product label warnings*. Health effects can range from minor problems, such as itchy, red skin or sneezing, to major problems, such as poisoning or burns.

You can be exposed to a hazardous ingredient by eating or drinking (ingestion), breathing dust or vapors (inhalation), skin contact or eye splash. The amount of harm from hazardous chemicals depends on:

- ◆ The types of chemicals in the product.
- ◆ How much of the ingredient you are exposed to.
- ◆ Your weight, age and state of health.

Some harmful effects appear right away (**acute poisoning**). Common symptoms are nausea, trouble breathing, itchy red skin, burning eyes, dizziness and headaches. Other effects, such as damage to lungs or kidneys, take a long time to occur (**chronic poisoning**).

## Environmental hazards

Household products can also be hazardous to plants and animals. For example, pesticides washing into a stream can kill fish. Contamination of the environment can in turn affect us. Our health can be threatened if the food we eat, the water we drink and the air we breathe become contaminated. Once released through improper use or disposal, some chemicals can last a long time and have many effects. Some can become a part of living systems and be passed from one plant or animal to another. If enough of a toxic (poisonous) chemical builds up, it could harm normal body functions.

Some cleanup or dumping practices may not seem likely to lead to trouble, but old habits should be looked at for possible risks. Remember:

- ✓ Don't dump oils, paints or pesticides on roads or down storm sewers.
- ✓ Don't dump anything in a wetland or stream.
- ✓ Don't dump used motor oil or antifreeze on the ground, down a storm drain or into any surface water.
- ✓ Don't pour chemicals into a drain that leads to a septic tank.
- ✓ Don't spray pesticides on a windy day or near lakes, streams or wetlands.
- ✓ Don't burn hazardous materials in a barrel or outdoor fire.
- ✓ Don't flush old or unwanted medications down the drain or toilet.

## Part 1 – Product Choice, Purchase and Use

Your choice of products is important. By carefully choosing the right amount of the right product for the job, you can control the amount of hazard you bring to your home. These facts will help you decide your risks from products you use.

### How can you tell which products are hazardous?

READ THE LABEL AND ALWAYS STORE THE PRODUCT IN ITS ORIGINAL CONTAINER. Labels contain signal words and important information about product use, storage and safe disposal, first aid and ingredients. Take a look at the labels on some of the products in your home. The label is especially important should someone accidentally ingest the product and you are calling Poison Control for help (see the blue box on the next page).





Many health problems can be avoided by carefully following label rules for safe use. *Remember, lack of a warning on a product label does not mean that the product is safe.* Use any chemical product with care and caution. Ask questions, and look for helpful ideas from health agency workers, your local Michigan State University Extension office, manufacturers, articles and books. Refer to Chart 1: Hazardous Products at the end of this chapter.

The **signal words** on the label—CAUTION, WARNING and DANGER—can mean different things, depending on the product. The signal word DANGER is required on any product that is very flammable, corrosive or toxic. Products labeled DANGER, FLAMMABLE, POISON, VAPOR HARMFUL or FATAL IF SWALLOWED may cause environmental harm as well as human health problems. In all cases, they signal that one should read the label and use care with these products. Some terms on labels, however, may be misleading. Companies can promote their products as “ozone safe” or “environmentally friendly,” but there is no common agreement about what these terms mean.

If you need more product advice than the label contains, you may want to ask for a material safety data sheet (MSDS) from the manufacturer. (Most companies give a phone number on their product label and will answer questions by phone.) You may also call the National Pesticide Information Center, 1-800-858-7378, for instant advice on toxicology, health and safety questions.

#### **In case of emergency**

Don't rely *only* on the label for information. **Poison Control**—a national computer data network—can give **emergency** health advice about a product.

**1-800-222-1222**

Keep this number close to your phone.

For reporting or information about spills of hazardous products, contact the Michigan Department of Environmental Quality (DEQ) at 1-800-292-4706.

#### **Can a different product do the job?**

When choosing from many brands of the same kind of product—for example, paint strippers or degreasers—look for the least hazardous product that will do the job. Unless you read the label, you may buy a hazardous product such as a petroleum-based cleaner when you could buy a water-based detergent or a kitchen cleanser. Read the label to find out what is the safest for you.

You may have some recipes for household cleaning products using common ingredients instead of hazardous chemicals. But your homemade products may *not* be safer. If you choose to make your own household products, be sure to follow these safety steps:

- ✓ Use only one ingredient at a time. Never mix ingredients or products without directions. Be sure to rinse between products used on one place.
- ✓ Always test any cleaner on a small area before using it for the whole job.
- ✓ Do not use food products such as vegetable oil or milk for cleaning. They may spoil or allow mold or bacteria to grow.
- ✓ Use clean containers when storing your homemade product. The date and all contents should be clearly written on the label. Make sure containers do not look like food or beverage containers.

## Do you buy only what you need?

If you buy more than you need, hazardous products may build up and create storage and/or disposal problems. Product containers may become damaged and leak. Some products are not useful after long storage. Some products, such as pesticides, may have been restricted or banned since they were bought. If that happens, safe use and disposal of these products becomes much harder. Avoid these problems by buying only what you need for the job at hand. If you find you have more than you need, offer to give it to someone who may be able to use it, or take it to a local household hazardous waste collection or Clean Sweep program. (See “Resources” at the end of this chapter.)

## ✓ Assessment 1 – Product Choice, Purchase and Use

Use the following assessment to rate your risks in the purchase and use of household products. For each question, put your risk level (low, medium or high) in the column “Your risk.” Some choices may not be exactly like your case, so choose the answer that fits best. Go to Part 1 above if you need help.

	<b>Low risk/ recommended</b>	<b>Medium risk/ potential hazard</b>	<b>High risk/ unsafe situation</b>	<b>Your risk</b>
<b>Product choice</b>	I always read labels and choose the least hazardous product that will do the job.	I sometimes read labels and occasionally avoid hazardous products.	I never read labels and purchase products regardless of hazards.	
<b>Amount purchased</b>	I buy what I need for specific jobs and use up most of the products within 6 to 12 months after purchase.	I buy more than I need and keep excess products more than a year.	I buy more than I need and throw excess away.	
<b>Safe use</b>	I follow label instructions and take recommended precautions against exposure (such as good ventilation, face masks, gloves).	I follow some label instructions.	I never follow label instructions, even when recommended.	

## Responding to risks

Your goal is to lower your health risks and reduce possible harm to the environment. Turn to the Action Checklist at the end of the chapter to write the medium and high risks you found. Use the advice above to help you reduce your risks.



## Be prepared—make a spill kit!

A spill kit is a very handy item to keep around the house should chemicals leak or spill. A spill kit contains items in one handy box to assist in the cleanup of dry or wet spills.

- ◆ Plastic storage tote – Holds materials in one location.
- ◆ Safety goggles – Protect eyes, one of the most sensitive areas on the human body.
- ◆ Chemical-resistant gloves – Nitrile gloves are suitable for most household chemicals; work gloves or gloves with linings do not provide adequate protection.
- ◆ Broom and dust pan – To sweep up dry spills.
- ◆ Garbage bags – For easy handling of leaky or spilled material.
- ◆ Cat litter or sawdust – To soak up liquid spills before sweeping and disposing.
- ◆ Emergency telephone numbers – To seek help if needed.

Figure 1: Hazardous products can be found throughout the home.  
Image by Karla Embleton and Amy Childress, Purdue University.

## Part 2 – Safe Storage

Leftover chemicals such as pesticides, paint, paint stripper, used motor oil and antifreeze need to be stored until they are used up or disposed of. Safe storage of hazardous products can help reduce your risk. Use the advice below to help you fill out the assessment at the end of this section.

### When you store hazardous products, do you:

- ✓ Keep them out of reach of children and pets?
- ✓ Store them in a locked, secure area?
- ✓ Store them in their original containers?
- ✓ Make sure all containers are clearly labeled and dated?
- ✓ Keep containers tightly sealed and dry?
- ✓ Store at least 150 feet from a well or wetland, lake or stream?
- ✓ Store batteries in a covered plastic container, away from all chemicals?
- ✓ Store flammable chemicals in a cool, well-ventilated area away from sparks or flame?
- ✓ Have a spill kit?

### Are your storage locations and containers really safe?

If you can smell a household product being stored, the lid may be loose or ventilation is not good enough to protect your health. Be sure to separate corrosives such as acid or lye from other hazardous products to prevent dangerous reactions or fire. Regularly check areas where you store hazardous products (under the kitchen sink, in the basement or garage) to make sure that containers are closed tightly, they are not leaking, and the sides are not bulging.

To view a virtual house showing where hazardous products are commonly found, what they are, their specific ingredients and disposal information, go to [www.purdue.edu/envirosft/housewaste/house/house.htm](http://www.purdue.edu/envirosft/housewaste/house/house.htm) (Figure 1).



## ✓ Assessment 2 – Product Storage Safety

Use the following assessment to rate your risks in the safe storage of household products. For each question, put your risk level (low, medium or high) in the column “Your risk.” Some choices may not be exactly like your case, so choose the answer that fits best. See Part 2 if you need more help.

	<b>Low risk/ recommended</b>	<b>Medium risk/ potential hazard</b>	<b>High risk/ unsafe situation</b>	<b>Your risk</b>
<b>Child safety</b>	Hazardous products stored in a locked cabinet or other location inaccessible to children/pets.	Hazardous products kept out of direct reach of children (on a high shelf) but still accessible.	Hazardous products easily accessible to children/pets (unlocked cabinet, lower shelf).	
<b>Safe storage</b>	Leftovers stored in original containers and properly sealed. Products sorted by type. Environment protected from spills, such as with secondary containment or impervious floor. Products protected from overheating or freezing.	Original containers stored in a disorganized way. No protection against leaks or spills. Products protected from overheating or freezing.	Leftovers kept in non-original containers such as used milk jugs or glass jars. Stored unlabeled without caps or lids. No protection for leaks and spills. Products not protected from overheating or freezing.	
<b>Ventilation</b>	Volatile products (such as solvents and petroleum-based fluids) stored in locked places with good ventilation.	No attention to storage location, but each container is in good shape and tightly sealed.	Products stored in basements, closets, crawl spaces or other areas with poor ventilation. Containers in bad shape or left open.	
<b>Spill kit</b>	Spill kit conveniently available for chemical spill emergencies.	Spill kit present but difficult to access.	No spill kit available.	
<b>A boxed risk level</b> indicates level required for Residential Environmental Assurance Program certification.				

### Responding to risks

Your goal is to lower your health risks and reduce possible harm to the environment. Turn to the Action Checklist at the end of the chapter to write the medium and high risks you found. Use the advice above to help you reduce your risks.

## Part 3 – Product Disposal

Unless a product is entirely used, you will have to get rid of it. Even the containers of really hazardous products, such as pesticides, must be disposed of safely. Use the advice below to help you fill out the risk assessment at the end of this section.



### What is the best way to get rid of leftover hazardous products?

You can avoid this problem by buying only what you need, using up your leftovers or recycling. Throwing a product away should be your last choice. Giving leftover products to a neighbor who will use them appropriately means you no longer have a hazardous waste problem. Some areas have swap programs to increase sharing, and choices for recycling are growing. Used motor oil and antifreeze can be recycled in many communities at car parts, car repair or oil change shops. Some products such as batteries are accepted back through an industry-supported program such as Rechargeable Battery Recycling Corporation (RBRC).





If these are not available, contact your local solid waste coordinator. To locate yours, go to the clickable map at [www.michigan.gov/deqreswastecontacts](http://www.michigan.gov/deqreswastecontacts). Your local solid waste coordinator will be able to tell you when the next household hazardous waste drop-off will be. If your area does not have such a program, contact your local garbage hauler for disposal advice. Some products may be safely sent to a landfill. For example, leftover latex paint can be dried in the can and then put in the garbage. Small quantities of oil-based paint can be solidified by adding cat litter or an oil spill absorption product. A small number of items are banned from landfills in Michigan. Information about what to do with these items is included in the “Talking Trash” brochure at [www.deq.state.mi.us/documents/deq-ess-p2tas-BannedLandfillMaterials.pdf](http://www.deq.state.mi.us/documents/deq-ess-p2tas-BannedLandfillMaterials.pdf)

**Pesticides.** Use a Clean Sweep or household hazardous waste dropoff program in your community to get rid of unwanted or unusable pesticides. You will need to make an appointment and provide the amount and type of pesticides you plan to bring in. This allows the hazardous waste coordinator to have the proper materials for handling your pesticides. To find your nearest Clean Sweep site, go to [www.michigan.gov/mda](http://www.michigan.gov/mda) and enter Map Clean Sweep in the search site and then click on MDA- Operation Clean Sweep. The pesticide label will provide container disposal advice. Some pesticide containers may be returned to the dealer for safe disposal.

**Pharmaceuticals.** Most of us have leftover, expired or unneeded medications around the house. They should not be flushed down the toilet or drain. Septic systems and city wastewater treatment systems are not designed to remove these chemicals. They have been identified in groundwater and surface water. This is a growing national concern. Check to see if the local pharmacy is taking back unwanted drugs. Some drugstores accept expired medications for disposal, but pharmacies cannot legally accept controlled substances from citizens. Find special collections for unused and expired drugs. Check with your household hazardous waste collection or recycling program coordinators to see if medications are accepted in your area. A list of contacts is at [www.deq.state.mi.us/documents/deq-ess-p2-recycle-countycontacts.pdf](http://www.deq.state.mi.us/documents/deq-ess-p2-recycle-countycontacts.pdf). If a collection program is not immediately available, follow the handling suggestions in the drug disposal section of the drug label/ insert.

**Sharps.** Disposal of sharps (needles, syringes and lancets) poses a particular risk to sanitation and sewage treatment workers, janitors, housekeepers and children. People exposed to loose sharps risk painful sticks or, worse, life-altering diseases. Users of sharps need to have a clearly labeled sharps container. Safe disposal options consist of drop-off collection sites (go to [www.michigan.gov/deq](http://www.michigan.gov/deq) and search for “sharps collection”), residential special waste pickup services, mail-back programs, syringe exchange programs and home needle destruction devices. Go to [www.epa.gov/epaoswer/other/medical/med-govt.pdf](http://www.epa.gov/epaoswer/other/medical/med-govt.pdf) for more info.

### Is dumping or burning a safe choice?

*Never* dump or bury hazardous products near wells or water. *Never* pour products down storm sewers. Some cleaning products that dissolve in water may be safely poured down the drain if flushed with plenty of water. Septic system owners need to be careful and not dump large amounts of *anything* into the septic system. *Never* burn hazardous waste in a burn barrel or stove. This may release toxic gases and leave hazardous ash. It may also cause an explosion.

## ✓ Assessment 3 – Product Disposal

The assessment on the following page gives general disposal advice. Check the waste group in the left-hand column and see if any of your disposal practices pose risks to your health or the environment. See Chart 1, “Hazardous Product Examples,” on page 33, for specific products.

### Responding to risks

Your goal is to lower your risks. Write your medium and high risks on the Action Checklist. Use the advice above to help you reduce your risks.

Waste group (refer to Chart 1)	Low risk/ recommended	Medium risk/ potential hazard	High risk/ unsafe situation	Your risk
<b>Household trash</b> Trash containing plastics or empty containers of hazardous ingredients.	I use up hazardous ingredients. I recycle or dispose of hazardous product containers at licensed landfill according to label. No burning done.	I burn hazardous containers. I dispose of ash from mixed trash on my property but away from my well or any water.	I burn hazardous containers near people or animals. I dispose of ash from mixed trash, leftover pesticides and chemicals on my land or near a well or water.	
<b>Strong acids and bases (corrosive)</b> Found in hobby products, cleaners and repair products.	I share leftover products or take to a landfill after packaging safely.	I pour strong acids and cleaners down a drain connected to a septic system without adding water.	I pour strong acids and cleaners into storm sewers, creeks or streams, or in a ditch leading to water.	
<b>Batteries</b> Mercury, cadmium and lead.	I recycle batteries or take them to a hazardous waste disposal program	I dispose of batteries in my garbage, which goes to a licensed landfill.	I dump batteries and chemicals in the same spot, near a well, water or stream.	
<b>Hazardous products</b>	I share, recycle or take leftovers to a hazardous waste disposal program. I follow the label for safe disposal.	I dispose of leftover products in a licensed landfill.	I don't follow the label. I dispose of leftover products in the same place, near a well or water, or dump leftovers in a stream.	
<b>Pesticides</b> (See Chapter 9, "Caring for the Yard and Garden.")	I handle all types of pesticides as directed on the label. Unwanted or unusable pesticides are taken to a Clean Sweep site.		I <i>do not</i> handle pesticides as directed on the label. I don't bother to properly dispose of unusable pesticides at Clean Sweep.	
<b>Pharmaceuticals</b>	I contact my local household hazardous waste coordinator about take-back programs in my area. I never flush waste medications down the drain or toilet.	I make my unwanted medications unusable by filling pill bottles with liquid soap and removing personal information from the bottle label, then wrap in bags and put in trash.	I flush all unused medications down the drain or toilet.	
<b>Sharps</b> Hypodermic needles, lancets.	I use a community take-back program for used sharps. I store them in a clearly labeled, safely stored container, and seal it when transporting to collection program.	I collect used sharps in a clearly labeled, puncture-proof container. When it is full, I seal the container and put it in the trash (NOT recycle bin).	I throw sharps away or flush down the drain.	

**A boxed risk level** indicates level required for Residential Environmental Assurance Program certification.



# Chart 1: Hazardous Product Examples

## Household trash

- ◆ ash/ sludge from home or garbage trash burn barrel
- ◆ used motor oil
- ◆ unrinsed pesticide or chemical containers
- ◆ empty containers from other hazard categories
- ◆ fluorescent light bulbs/tubes

## Clothing and fabric care products, personal products

- ◆ mothballs
- ◆ dry-cleaning fluids
- ◆ spot removers (solvent-based)
- ◆ shoe/leather polishes
- ◆ fingernail polish
- ◆ polish remover
- ◆ hair sprays

## Hobby and recreation products

- ◆ artist paints and solvents
- ◆ charcoal lighter fluid
- ◆ strong acids and bases
- ◆ household batteries (mercury or cadmium)
- ◆ chemistry set
- ◆ photography and swimming pool chemicals

## Household cleaners

- ◆ bleach
- ◆ ammonia
- ◆ oven cleaner
- ◆ drain opener
- ◆ toilet bowl cleaner

## Medical

- ◆ unwanted medications
- ◆ used sharps

## Pesticides

- ◆ pesticides (general and restricted-use)
- ◆ old (banned) pesticides
- ◆ unwanted pesticides (insecticides, fungicides, herbicides, etc.)

## Automobile products

- ◆ antifreeze, motor oil, grease
- ◆ gasoline
- ◆ solvents for oil and grease removal
- ◆ engine, parts cleaners: transmission, carburetor, brake quieter
- ◆ paints and paint preparation products
- ◆ lead-acid battery
- ◆ battery terminal cleaner
- ◆ tire cleaners
- ◆ rust removers
- ◆ ignition wire dryer
- ◆ gasket removers
- ◆ aerosol paint and primer products
- ◆ lubricants
- ◆ other fluids

## Home improvement/repair products

- ◆ building and wood cleaners
- ◆ wood polishes
- ◆ wood floor and panel cleaning products
- ◆ paint stripper

## Building and equipment maintenance products

- ◆ strong acids and bases
- ◆ lead-based paint
- ◆ oil/alkyd paints
- ◆ paint primer
- ◆ aerosol paint
- ◆ stains and finishes
- ◆ roof coatings and sealants
- ◆ rust removers
- ◆ silicon lubricants
- ◆ other lubricants
- ◆ adhesives, glues and caulk
- ◆ wood-preservative products
- ◆ brush or spray gun cleaners
- ◆ wood and cement water repellents
- ◆ solvents for degreasers and paint thinners, stains, varnishes

## ✓ Action Checklist

When you finish the assessments, go back over them to find high and medium risks. Write them below. For each one you found, write down the changes you plan to make. Use ideas from this chapter and other sources (see list below). Pick a target date to keep you on track for making changes. You don't have to do everything at once, but try to change the greatest risks as soon as you can. Often it helps to start with less expensive actions first.

List the high and medium risks	What can you do to reduce the risk?	Target date for action
Example: Cabinet with cleaning solvents and paint stripper is not childproof.	Buy a lock and install on cabinet.	One week from today: November 28

## Resources

**Hazardous products** – Contact the manufacturer.

**Pesticides** – Contact the manufacturer, the Michigan Department of Agriculture regional office in your area or your local Michigan State University Extension office.



## Publications

**“Reading a Pesticide Label.”** Bulletin E-2182  
(also available in Spanish: E-2182SP), Michigan State University Extension.

**“Citizen’s Guide to Pest Control and Pesticide Safety.”** 1995.  
EPA Booklet 730-K-95-001.  
Contact: National Center for Environmental Publications and Information,  
P.O. Box 42419, Cincinnati, OH 45242-2419. May be downloaded at  
[www.epa.gov/oppead1/Publications/Cit\\_Guide/citguide.pdf](http://www.epa.gov/oppead1/Publications/Cit_Guide/citguide.pdf).

**“Toxics in Your Home.”** Tip of the Mitt Watershed Council brochure.  
Contact: Tip of the Mitt Watershed Council, 426 Bay St., Petoskey, MI 49770.  
Phone: 231-347-1181.

## Further Information

The Ecology Center  
117 N. Division St.  
Ann Arbor, MI 48104-1580  
Phone: 734-761-3186  
Email: [info@ecocenter.org](mailto:info@ecocenter.org)

Contact for educational environmental programs, classroom-ready environmental material, phone call assistance, the “GEE-Wow!” children’s newsletter and much more.

East Michigan Environmental Action Council (EMEAC)  
21220 West Fourteen Mile Road  
Bloomfield Township, MI 48301  
Phone: 248-258-5188  
Contact for various environmental and household publications, groundwater information, brochures, flyers, fact sheets and more.

Hazards in the Home (Virtual)  
[www.purdue.edu/envirosoft/housewaste/house/house.htm](http://www.purdue.edu/envirosoft/housewaste/house/house.htm)

Household Hazardous Waste Programs  
Go to clickable map at [www.michigan.gov/deqreswastecontacts](http://www.michigan.gov/deqreswastecontacts).

Michigan Clean Sweep Program  
For disposing of pesticides. Go to [www.michigan.gov/mda](http://www.michigan.gov/mda).  
Enter “Clean Sweep” in search bar, click “MDA - Clean Sweep” then click  
“Clean Sweep Contact Information by County.”

Michigan Technological Center for Science and Outreach  
1400 Townsend Drive, Houghton, MI 49931  
Phone: 906-487-3341  
Email: [kbradof@mtu.edu](mailto:kbradof@mtu.edu)  
Contact for general information on hazardous household products.

Environmental Hazards Management Institute (EHMI)

P.O. Box 932, Durham, NH 03824

Phone: 1-800-446-5256

[www.ehmi.org](http://www.ehmi.org)

Contact for various environmental products and information (e.g., Household Hazardous Waste Wheel).

West Michigan Environmental Action Council (WMEAC)

1007 Lake Dr. SE, Grand Rapids, MI 49506

Phone: 616-451-3051

[www.wmeac.org](http://www.wmeac.org)

Contact for sustainable living, sustainable agriculture and water quality resources.

Contact your Michigan State University Extension office, county conservation district office, or government office in your county or city for various other materials related to this subject.

This Home\*A\*Syst chapter does not cover all possible risks due to household hazardous wastes that could affect your health or environmental quality. Other chapters on various topics help homeowners look at their most important environmental concerns.

This chapter was written by Elaine Andrews, Environmental Resources Center, Cooperative Extension, University of Wisconsin Extension, and adapted for Michigan by Ann Chastain, Roberta Dow and Jim Bardenhagen, Michigan State University Extension, and Jill Send, AmeriCorps. Updated in 2008.





**T**his chapter addresses sources of lead in and around the home and explains the health hazards associated with exposure to lead. Completing the assessments will help you identify and evaluate lead-related risks to your family's health. This chapter is divided into four parts:

### 1. Identifying lead sources inside the home

- ◆ Lead-based paint in or on pre-1978 homes
- ◆ Lead in drinking water from contact with lead pipes, lead-based solder or other plumbing sources

### 2. Identifying lead sources outside the home

- ◆ Leaded exterior paint
- ◆ Automobile exhaust
- ◆ Industry

### 3. Health effects of lead on children

- ◆ Avenues of exposure
- ◆ Effects and symptoms of poisonings

### 4. Living safely with lead

- ◆ Cleaning existing lead contamination in the home
- ◆ Containing lead sources to prevent poisoning



Michigan  
Groundwater  
Stewardship  
Program

**MICHIGAN STATE**  
**UNIVERSITY**  
**EXTENSION**

## Chapter 4. Lead in and around the Home: Identifying and Managing its Sources

### Why should you be concerned?

Lead poisoning is a serious but preventable health problem. Many public health experts consider it the No. 1 children's environmental health problem in the United States. Many homes have one or more sources of lead. According to data from the National Health and Nutrition Examination Survey (1999-2000), an estimated 434,000 children ages 1 to 5 years had blood lead levels of greater than or equal to 10 micrograms per deciliter ( $\mu\text{g}/\text{dL}$ ) at a given time. The chief suspect is lead-based paint dust in older homes. Families can also be exposed to lead from other sources.

**Lead** is a soft metal that has been used in ammunition, ceramics, printer's ink, children's toys, solder, paint, coins, leaded crystal, water pipes and gasoline, and for many other purposes. Lead is dangerous because it is so widely used and lasts for hundreds of years in the environment. It never breaks down into a harmless substance. You can take steps to reduce your exposure to lead, but you cannot completely avoid it. Reducing exposure is especially important for children.

Depending on the level, lead can have wide-ranging effects in humans. Even very low lead levels in children can slow or stop mental development and cause learning and behavioral problems. Lead can also cause high blood pressure. Higher levels may cause damage to the nervous system and the reproductive system. Sadly, the effects of lead poisoning are often not reversible.

### Where are the lead sources in and around the home?

The most common sources of lead are deteriorating lead-based paint, household dust (which can contain lead dust from deteriorating lead-based paint or remodeling), soils contaminated by leaded paint or leaded gasoline exhaust, and drinking water delivered through lead pipes or in contact with lead solder or some brass faucets. Over the years, lead has been eliminated by law in residential paint, gasoline, solder and water pipes. However, many older homes contain lead paint, and even newer homes can contain lead from other sources. Unlike many chemicals, lead does not break down and can remain for long periods in paints, dusts and soil.



## ✓ Part 1 – Identifying Lead Sources Inside the Home

Identifying and controlling sources of lead in and around your home is an important responsibility. To determine potential risks from sources inside your home, complete the assessment at the end of this section. The information below will help you answer the assessment questions.

### When was your home built?

According to the U.S. Department of Housing and Urban Development, 74 percent of all homes built before 1980 contain potentially dangerous levels of lead paint. Although lead has been banned from house paint since 1978, the majority of U.S. homes were built before then. Homes built before 1950 are very likely to have high lead levels, especially in paint used on windows and exterior surfaces. Levels as high as 25 to 35 percent lead by weight are common. Some pre-1950 paint was 50 percent lead.



### Does your interior paint contain lead? What is its condition?

Lead-based paint is the most common source of lead exposure for children. Most exposure, however, comes from contact with contaminated household dust rather than eating paint chips. As paint ages or as painted surfaces rub against each other, lead-containing dust is created. If your lead-based paint is perfectly intact, then the potential risk of ingestion is greatly reduced. But if paint is cracking, chipping, flaking or being rubbed by contact, the danger of lead exposure is much higher.

### Testing for lead

In Michigan, two types of lead identification can be done on homes: a lead inspection and a risk assessment. The inspection will look for how much lead is in interior and exterior paint. The assessment will determine the lead dangers in and outside the house and how to reduce them.

To find out if your paint contains lead – and if so, how much – have it analyzed by experts who test samples in a laboratory or who examine paint on-site using a portable X-ray fluorescence (XRF) detector. Surface wipe samples, which are used to test dust for lead contamination, may be taken by lead professionals and sent to a lab for analysis. Some laboratories may analyze surface wipe samples collected by the homeowner. Do-it-yourself home test kits are available in stores. They indicate the presence or absence of lead but do not indicate how much lead is present. Home test kits may not be reliable for testing surfaces in your home; it is best to have such tests done by a professional. Check with local health officials or the Michigan Department of Community Health’s website at [www.michigan.gov/leadsafe](http://www.michigan.gov/leadsafe).



### If you find lead...

Remodeling or renovating in areas having lead-based paint is especially risky. Scraping, sanding or burning lead-based paint creates extremely hazardous conditions, and strict precautions need to be taken – especially if children, pregnant women or pets are present. If possible, homeowners should use the services of a certified lead-abatement contractor. Certified Michigan lead service providers can be found at the LeadSafe website, or by calling the Department of Community Health Lead Program toll-free at 1-866-691-5323. Paint removal, replacement of lead-painted parts (such as windows, door jambs and moldings), liquid encapsulants (special paint-like products that cover a surface) and removal of leaded surfaces are some of the options for dealing with lead paint. Lead-based paint removal by untrained workers who do not use the proper methods and equipment can create a much greater health hazard than just leaving the paint alone.

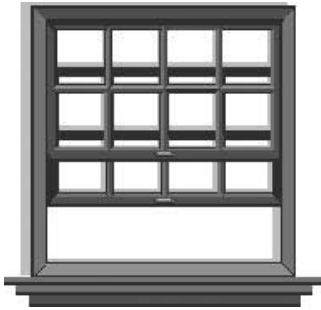

Figure 1: High friction areas, such as inside window frames, are likely sources of lead dust, which falls to the sill and floor.

### Is there lead paint on windows and door frames? What is their condition?

Paints with higher lead levels were used where exposure to moisture was greatest: windows, doors and exterior walls. If high lead-based paint is intact, it poses little risk. If it is chipping or chalking off or is scraped or sanded during repairs, then the risk of exposure is great. Lead dust, most dangerous to kids and pets, is likely to come from weathering (chalking) paint and especially from surfaces that bang or slide together, such as doors and windows (Figure 1).

#### Safety note

If you're planning to do any remodeling yourself, you should become knowledgeable about lead paint. Contact the National Lead Information Center (NLIC) at 1-800-424-LEAD. Many communities offer "Lead Safe Work Practices," an 8-hour training program through the U.S. Department of Housing and Urban Development and the U.S. Environmental Protection Agency (EPA). A do-it-yourself guide to lead-safe painting, repair and home improvement may be obtained online at [www.michigan.gov/mdch](http://www.michigan.gov/mdch). Enter "Don't Spread Lead" in the search bar. You may also want to contact local landfills about what remodeling wastes they accept and if they have special requirements for lead-contaminated waste from the home.

## How else can lead enter the home?

**In consumer products**—Lead is present in such products as lead-crystal glassware and leaded wine bottle neck wraps made before 1990. It may also be in some foreign-made products such as toys, miniblinds, chalk, crayons, ceramics and food cans (which may be made with lead solder). Although lead is now less common in printing inks, it may be present in food packaging labels and newspaper print.

**From the workplace**—Do you work in construction, bridge building, sandblasting, shipbuilding, plumbing, battery manufacturing, auto radiator repair, furniture refinishing or foundry casting? If so, leaded dust from your worksite can be carried into your home on your clothing, skin and hair. Workers exposed to leaded dust should shower and change clothes before entering the home.

**In hobby and recreation supplies**—If your hobbies include stained glass, furniture refinishing, pottery (using lead glazes), or collecting pewter or lead figurines, you may be exposing yourself and others to lead. Hunters and anglers who use or make lead bullets and lead sinkers also come in contact with lead. Exposure can also occur at indoor firing ranges.

**In ethnic medicinals or cosmetics**—Various Hispanic and Asian communities utilize mixtures that contain high levels of lead. Some stomach preparations are quite toxic.

## Is your drinking water lead-free?

Although your drinking water is not usually a concentrated lead source like paint or soil, it can still pose risks to your family. Lead can enter your water from several points: lead pipes that bring water to the home, lead pipe connectors, lead-soldered joints in copper plumbing, and lead-containing brass faucets and pump components. In some private wells, underwater pumps with brass fittings can cause elevated lead concentrations in drinking water, especially with new pumps or if the water is soft (lacking calcium or magnesium minerals). Water that is soft or acidic (less than pH 7) can be corrosive and dissolve lead from pipes and fittings more easily. Lead solder with more than .2 percent lead and faucets and other plumbing features with more than 8 percent lead were banned in the United States in 1987. Buildings had to be built with certified “lead-free” (less than 8 percent) fixtures after August 1998. Home water softeners, though they do have benefits, may increase the amount of lead leached into your drinking water if lead is present in your water system.

## What can you do to minimize lead in your water?

Water testing will show if lead is present in your water and whether your water is “aggressive” (acidic or soft). This is a special test, not part of the partial chemical test. Contact a state-certified laboratory or health agency for instructions on how to take a lead water sample. To find a certified lab near you, go to [www.deq.state.mi.us/documents/deq-ead-tas-labs-michlabs.pdf](http://www.deq.state.mi.us/documents/deq-ead-tas-labs-michlabs.pdf). If lead levels are greater than 15 parts per billion (ppb), action is recommended.

A simple way to reduce lead concentrations is to flush your plumbing system. You must, however, test a sample from flushed water to be sure that it is below the lead level of 15 ppb. If your water system has not been used for more than four hours, flush the system by letting cold water run for a minute or two before using it for drinking or cooking.

Also, always use cold tap water for cooking and drinking; hot water is more likely to release lead if present in the plumbing system. Never use water with high lead levels (over 15 ppb) to mix infant formula. For severe lead contamination, you may need to install a water treatment device, such as a



Figure 2: Using bottled water for drinking and cooking is one option for dealing with lead-contaminated water.

reverse osmosis system, a distillation system or an activated carbon filter. Buying bottled water for drinking and cooking may be the easiest and least expensive option for dealing with severe lead contamination (Figure 2). Be aware, however, that bottled water is not necessarily lead-free. Water treated by distillation or reverse osmosis is usually best. Call or write to the company and request a copy of its most recent water test results.

## ✓ Assessment 1 – Identifying Lead Sources Inside the Home

Use this assessment to rate your lead-related indoor health risks. For each question, indicate your risk level (low, medium or high) in the right-hand column. Although some choices may not correspond exactly to your situation, choose the response that best fits. Refer to the information in Part 1 if you need help completing the assessment.

	<b>Low risk/ recommended</b>	<b>Medium risk/ potential hazard</b>	<b>High risk/ unsafe situation</b>	<b>Your risk</b>
<b>Age of home</b>	Built after 1978.	Built between 1950 and 1978.	Built before 1950.	
<b>Interior paint</b>	No lead-based paint.	Lead-based paint present but intact.  Friction and impact areas tested negative for lead.	Deteriorating lead-based paint: it is chipping, peeling or chalking, or recent remodeling has disturbed the paint.	
<b>Windows and doors</b>	No lead-based paint. Windows and doors with lead-based paint have been replaced.	Lead-based paint present but intact.  Friction and impact areas tested negative for lead.	Deteriorating lead-based paint: it is chipping, peeling or chalking, or recent remodeling has disturbed the paint.	
<b>Water supply</b>	No lead water pipes, leaded solder or brass fixtures used in plumbing.	Lead present in plumbing, but water has been tested and precautions have been taken.	Lead likely to be present in plumbing, but water has not been tested and no precautions have been taken.	
<b>Water acidity or corrosiveness</b>	Hardness is near 80 milligrams per liter (mg/L). pH = 7.5 to 8.5	Hardness is 60-80 mg/L. pH = 6 to 7.5	Hardness is 60 mg/L or less. pH = less than 6	
<b>A boxed risk level</b> indicates level required for Residential Environmental Assurance Program certification.				

### Responding to risks

Your goal is to lower your risks. Turn to the Action Checklist at the end of this chapter to record the medium and high risks you identified. Plan actions to help you reduce your risks.

## Part 2 – Identifying Lead Sources Outside the Home

### Is your family tracking lead into the home?

The soil around your home can be a significant source of lead exposure, and levels tend to be highest where house walls meet the ground (Figure 3). Lead-contaminated soil is a problem when children play outdoors, soil is tracked inside the home by people and pets, and vegetables are grown in contaminated soil. Soils may be contaminated by flaking, peeling or chalking lead-based paint that follows the drip line of the house.

In high-traffic areas, leaded gasoline exhaust has been responsible for high levels of lead in soil, with levels highest near major roadways. The shift to unleaded gasoline has reduced this risk, but after years of contamination, lead levels can still be high in the soil.

If you live near industrial sources such as incinerators, lead smelters and battery recyclers, you should be concerned about lead in your soil. Urban residents should consider having their soil tested before planting a vegetable garden.



Figure 3: Chipped paint can cause lead contamination of the soil.

### What can soil tests reveal?

Testing your soil is the only way to detect a lead problem. To take samples yourself, contact a laboratory participating in the National Lead Laboratory Accreditation Program, or hire a Michigan certified lead risk assessor to take and submit a sample. You can also get your soil tested through a few local health departments and Michigan State University Extension offices for a fee. If high lead levels are found, there are several steps you can take. Planting grass or covering soil with mulch can keep your family from tracking the soil indoors. In some cases, removal and replacement of heavily contaminated topsoil may be recommended.

### What level is safe?

Lead exists naturally in soils. It is recommended that children and pregnant women avoid soils with lead levels above 300 parts per million (ppm). If you're planting a garden in soils with levels above 300 ppm, information is available for gardening practices (see additional resources at the end of this chapter).

Lead levels in soil near busy roadways are typically 30 to 2,000 ppm higher than natural levels. Soils adjacent to houses with leaded exterior paint are likely to have higher lead levels. Levels near industrial sources can be dangerously high, especially in downwind areas. Old orchards may also have high lead levels due to lead-containing pesticides applied in the 1940s and 1950s.

## ✓ Assessment 2 – Identifying Lead Sources Outside the Home

Use the following assessment to rate your health risks due to lead outdoors. For each question, indicate your risk level (low, medium or high) in the right-hand column. Although some choices may not correspond exactly to your situation, choose the response that best fits. Refer to the information in Part 2 if you need help completing the assessment.

	<b>Low risk/ recommended</b>	<b>Medium risk/ potential hazard</b>	<b>High risk/ unsafe situation</b>	<b>Your risk</b>
<b>Lead-based paint on exterior of house</b>	No lead-based paint, or it is present but intact. No bare soil around all sides of the house.	Lead-based paint is weathered or chalking. There is lead-based paint in the soil around the home, but no foot traffic.	Lead-based paint is chipping, peeling or chalking. There is bare soil and foot traffic below painted walls.	
<b>Major roadways</b>	No major roadway nearby.		Major roadway within 85 feet.	
<b>Lead-related industry</b>	No lead-related industry or incinerators in the area.	Lead-related industry previously in area.	Lead smelter, battery manufacturer or recycler, or other lead-related industry nearby.	
<b>Lead in soil</b>	Soil tested to detect lead. Shoes taken off upon entering house and track mats used at house entrance.	No soil test conducted. Shoes taken off upon entering house and track mats used at house entrance.	No soil test conducted. No precautions taken to ensure lead-contaminated soil is not tracked inside.	
<b>A boxed risk level</b> indicates level required for Residential Environmental Assurance Program certification.				

### Responding to risks

Your goal is to lower your risks. Turn to the Action Checklist at the end of this chapter to record medium and high risks you identified. Plan actions to help reduce your risks.

## Part 3 – Health Effects of Lead on Children

### Have children who live in or frequently visit your home been tested for lead?

Children 6 years old and younger are much more likely to be affected by lead than adults. They are more likely to ingest lead paint, dust and soil because they naturally engage in hand-to-mouth activities. Children are also at greatest risk from lead because their bodies are developing, and they absorb up to 50 percent of the lead they ingest. Adults absorb only about 10 percent.

Most children with lead poisoning do not show visible symptoms, but all have some degree of damage to the brain and nervous system. A blood test is the only way to detect the problem (Figure 4). At higher levels of poisoning, symptoms may include tiredness, a short attention span, restlessness, poor appetite, constipation, headache, sudden behavior change, vomiting and hearing loss. Many of these symptoms may be mistaken for other illnesses.

Lead is widespread in our environment, so it is almost impossible to have a zero level in the blood. Lead levels are measured in micrograms per deciliter ( $\mu\text{g}/\text{dL}$ ) of blood. Levels of 10  $\mu\text{g}/\text{dL}$  or higher are considered elevated in children and are of medical concern.



Figure 4: A blood test is the only way to detect lead poisoning in children.

## ✓ Assessment 3 – Health Effects of Lead in Children

Use this assessment to rate your children’s health risks due to lead. Indicate the risk level in the right-hand column. Refer to the information above if you need help completing the assessment.

	Low risk/ recommended	Medium risk/ potential hazard	High risk/ unsafe situation	Your risk
<b>If home built before 1978</b>	Children under 6 years living in or frequently at the home have lead blood test.		Children under 6 years of age in or often at the home not tested.	
<b>Blood test results in children</b>	Blood lead level is under 5 $\mu\text{g}/\text{dL}$ .	Blood lead level is 5 to 9 $\mu\text{g}/\text{dL}$ .	Blood lead level is 10 $\mu\text{g}/\text{dL}$ or higher.	
<b>A boxed risk level</b> indicates level required for Residential Environmental Assurance Program certification.				

### Responding to risks

Your goal is to lower your risks. Turn to the Action Checklist at the end of this chapter to record the medium and high risks you identified. Plan actions to help reduce your risks.

## Part 4 – Living Safely With Lead

### What are some safe cleaning practices you can use to reduce your risk of lead exposure?

The first step to making your home a lead-safe environment is purchasing the correct supplies you need. You may already have some of these items at home, but make sure to get latex gloves, absorbent wipes, garbage bags, a spray bottle, liquid detergent, disposable towels and a mop. A final item to obtain is a high efficiency particulate air (HEPA) vacuum, which can in some cases be obtained from your local health department. Please note: a regular vacuum is not recommended because it will not capture lead dust.

A HEPA vacuum has a high efficiency particulate air filter built in that catches fine lead dust. This filter catches up to 99 percent of the dust and dirt sucked into the vacuum. The HEPA vacuum should meet American National Standards Institute (ANSI) Z9.2 standards and Occupational Safety and Health Administration (OSHA) and Environmental Protection Agency (EPA) regulations.



Check the vacuum owner's manual before using, and do not open or change the bag or empty any contents inside your home.

### Inside the home

After obtaining a HEPA vacuum, use this vacuum on windows, floors and porches. Follow this step by lightly misting with a soap solution. If a HEPA vacuum is not available, carefully remove dirt and paint chips with a wet disposable towel, put it in a plastic bag and put it in the trash. Replace towels until the surface is clean. Wipe surfaces clean by applying pressure. This has been proven to be effective in removing lead dust. Misting with the soap solution and then wiping with towels is a key step. During this cleaning process, you should also keep windows closed until the cause of the dust hazard is removed. If windows must be opened, restrict children from touching window parts. Remove loose paint from the trough area, repaint and cover the trough with metal or plastic. Install jam liners and sash kit, while replacing stops. Additionally, any replacement of windows that occurs should be conducted by a Michigan certified abatement company. Contact your local county health department for more information about lead abatement and financial assistance options, or visit the Michigan Department of Community Health lead website (see "Resources" at the end of this chapter). Encapsulant paint can be used but only on frictionless surfaces.

When working with doors, many of the same steps above should be used. The key is to eliminate all friction points. Install felt liner on door stops and scrape and repaint the door. Rehang the door with new hardware if needed to eliminate further friction and/or impact problems. Again, if you are replacing a large item such as a door, make sure to have this done by a certified abatement company.

When working in storage areas, make note of places used to prepare or eat food. If lead painted shelving or cabinets are used for food, cooking or eating utensils, linen or clothing, remove and clean these items and store in a safe area until the hazardous lead area has been treated. Replace, repaint and line all surfaces with vinyl, plastic or a similar covering. Adjust doors, hinges and other hardware to further eliminate friction or impact.



Figure 5: If possible, replace lead-containing items with new. Remember to use lead-safe work practices.

For floors, damp mop vinyl and wood flooring with paper towels and a soap solution. Start at the back of the room and work toward the exit door. You will want to change towels often until no paint chips or dirt can be seen. Place them in a garbage bag, and seal with a tape or a knot. The bag can be put out for normal trash pickup.

### Outside the home

When working on the outside of the home, put a tarpaulin down to catch paint chips, wet painted surfaces to be scraped, remove loose paint on siding, trim, railings and posts, and repaint. When the source of lead is deterioration, remove loose paint and seal off the damaged area. The best scenario is to replace the damaged component. This should be done by a certified abatement company. The next best thing would be to repaint.

If swings, sandboxes or other children's objects are in the contamination or work area, relocate them to another area of the yard where ground cover is in good condition. Instruct your children not to dig or play in the leaded soil. The best-case scenario would be to remove soil to a depth of 6 inches and backfill to the original ground height using non-lead soil, then seed or sod the site.

## ✓ Assessment 4 – Safe Cleaning and Care Practices

Use the following assessment to rate your cleaning and management practices inside and outside the home. Indicate the risk level in the right-hand column. Refer to the information in part 4 if you need help completing the assessment.

	<b>Low risk/ recommended</b>	<b>Medium risk/ potential hazard</b>	<b>High risk/ unsafe situation</b>	<b>Your risk</b>
<b>Vacuum used for lead-safe cleaning</b>	Use a HEPA vacuum for cleaning.		Use a regular vacuum for cleaning.	
<b>Window areas</b>	All surfaces wet wiped; paint chips removed and window areas repainted.	Paint chips removed; windows kept closed.	Paint chips left on window area; window kept open.	
<b>Door areas</b>	Friction and impact points eliminated; felt liners installed; door wetted, scraped and re-painted.	Paint chips removed safely.	Paint on door is chipping and not removed.	
<b>Storage areas</b> (shelving, cabinets, closets)	Items used for food are stored in lead-free area; friction/impact points eliminated; surfaces repainted and relined with a vinyl or plastic covering.	Items used for food are stored in non-lead area; surfaces not repainted and relined.	Items used for food remain in lead-contaminated area; surfaces not repainted or relined.	
<b>Disposal techniques</b>	Cleaning towels changed often; all cleaning items placed in sealed garbage bag and put out in trash.		Towels reused or cleaning items left in open trash.	
<b>Outside siding, trim and fixture areas of the home</b>	Loose paint removed; deteriorated items removed and replaced.	Paint chips removed; deteriorated items repainted or sealed off with vinyl or plastic coverings.	Loose paint chips remain.	
<b>Soil outside of home</b>	Children’s play equipment moved onto area with ground cover; bare soil roto-tilled and reseeded or sodded.	Children’s play equipment moved onto area with ground cover; bare soil remains.	Bare, lead-contaminated soil in play area.	

### Responding to risks

Your goal is to lower your risks. Turn to the Action Checklist at the end of this chapter to record medium and high risks you identified. Plan actions to help reduce your risks.





## ✓ Action Checklist

Go back over the assessments and look for all medium and high risks you identified. Write them below. For each item listed, write down the improvements you plan to make. Use recommendations from this chapter and other resources to decide on actions you are likely to complete. A target date will keep you on schedule. You don't have to do everything at once, but try to eliminate the most serious problems as soon as you can. Often it helps to tackle the inexpensive and/or less time-intensive actions first.

Write all high and medium risks here.	What can you do to reduce the risk?	Target date for action:
Example: House was built in 1935. Paint has not been tested for lead.	Arrange for lead risk assessment of the paint. Test for lead dust.	One week from today: April 3

## Resources

### Blood tests

Contact your family physician, pediatrician or public health clinics.

### Testing of paint samples and drinking water

Contact your local health department (offered only by a few) or private testing laboratories.

Certified water testing laboratories: [www.deq.state.mi.us/documents/deq-ead-tas-labs-michlabs.pdf](http://www.deq.state.mi.us/documents/deq-ead-tas-labs-michlabs.pdf)

Approved lead laboratories: [www.michigan.gov/leadsafe](http://www.michigan.gov/leadsafe)

Certified Michigan lead service providers: [www.michigan.gov/leadsafe](http://www.michigan.gov/leadsafe) or call toll-free 1-866-691-5323.

### Educational information for parents and others

Contact your county's Michigan State University Extension office.

## National Lead Information Center

To order a packet of material about lead, including information specific to your state and locality, call the center toll-free at 1-800-LEAD-FYI. For personal assistance on a lead-related question, call 1-800-424-LEAD.

## Poison Control Centers

DeVos Regional Poison Control Center, Grand Rapids, Mich. Call toll-free at 1-800-222-1222.

## Other useful websites

[www.hud.gov/lead](http://www.hud.gov/lead)

[www.epa.gov/lead](http://www.epa.gov/lead)

[www.cdc.gov/lead](http://www.cdc.gov/lead)

## Publications

**“Don’t Spread Lead: A do-it-yourself guide to lead-safe painting, repair and home improvement.”** Go to [www.michigan.gov/mdch](http://www.michigan.gov/mdch). Enter “Don’t Spread Lead” into search bar.

**“Get the Lead Out: Preventing Childhood Lead Poisoning through Partnership.”** At [www.HealthyHomesCoalition.org](http://www.HealthyHomesCoalition.org).

**“Lead in Your Drinking Water: Actions You Can Take to Reduce Lead in Drinking Water.”** At [www.epa.gov/safewater/lead/lead1.html](http://www.epa.gov/safewater/lead/lead1.html)

**“Lead Paint Safety: A Field Guide for Painting, Home Maintenance, and Renovation Work.”** March 2001. U.S. Department of Housing and Urban Development Office of Healthy Homes and Lead Hazard Control. Available from the National Lead Information Center at 1-800-424-5323 or at [www.hud.gov/offices/lead](http://www.hud.gov/offices/lead). Publication # 1779-LHC. Also available through EPA at [www.epa.gov/lead/pubs/leadsafetybk.pdf](http://www.epa.gov/lead/pubs/leadsafetybk.pdf).

**“Reducing Lead Hazards when Remodeling Your Home.”** 1997. EPA 747-K-97-001. U.S. Environmental Protection Agency. [www.epa.gov/lead/pubs/rrpamph.pdf](http://www.epa.gov/lead/pubs/rrpamph.pdf)

**“Soil Lead Levels.”** University of Massachusetts, Amherst, Department of Plant and Soil Sciences, Soil and Plant Tissue Testing Laboratory. [www.umass.edu/plsoils/soiltest/lead1.htm](http://www.umass.edu/plsoils/soiltest/lead1.htm)

This Home\*A\*Syst chapter covers a variety of topics to help homeowners examine and address their most important environmental concerns. See the complete list of chapters in the table of contents at the beginning of this handbook. For more information about topics covered in Home\*A\*Syst or for information about laws and regulations specific to your area, contact the Michigan Groundwater Stewardship Program (MGSP) at 517-241-2154.

This chapter was written by Karen Filchak, Extension educator, University of Connecticut Cooperative Extension, Brooklyn, Conn. Revised with permission from the author and adapted for Michigan in 2008.



This chapter identifies where indoor air problems come from and what can be done to eliminate them. Health hazards related to air quality can be serious, but there are many opportunities for action. This chapter covers:

### 1. Identifying and controlling potential sources of air quality problems

- ◆ Combustion byproducts
- ◆ Building materials
- ◆ Biological contaminants
- ◆ Household products and chemicals
- ◆ Radon
- ◆ Methane

### 2. Ventilating indoor air

- ◆ Ventilation
- ◆ Air cleaning

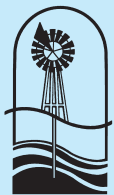

Michigan  
Groundwater  
Stewardship  
Program

**MICHIGAN STATE**  
**UNIVERSITY**  
**EXTENSION**

## Chapter 5. Indoor Air Quality: Reducing Health Risks and Improving the Air You Breathe

### Why should you be concerned?

Clean air is a precious asset – fresh, full of oxygen, clean-smelling and without harmful pollutants. If you are like most people, you spend at least half of your life inside your home. The air in many modern American homes, however, may not be fit to breathe. It can be more polluted and dangerous to your health than outdoor air. If your home has poor air quality, it may be simply annoying or unpleasant, or it may lead to serious health problems.

### What are the signs of trouble?

It is not always easy to detect poor air quality. Although you can smell paint vapors and see smoke, many harmful pollutants, such as deadly carbon monoxide gas, are invisible and odorless. Common health problems, such as irritated eyes and nose, headaches, dizziness, tiredness, asthma, viral infections and respiratory diseases, may be due to substances in the air you breathe. Some serious effects of poor air quality, such as lung cancer, may take many years to develop. People react differently to contaminants depending on their age, sensitivity and health status, and the type and length of exposure.

## Part 1 – Identifying and Controlling Potential Sources of Air Quality Problems

Finding the source—or sources—of pollutants should be your first step. Addressing problems at the source is usually the most cost-efficient and effective approach. If you do nothing else, dealing with the most troublesome sources can lead to better health for everyone who breathes the air in your home. Poor air quality is usually not the result of a single pollutant. Reducing health risks to you and your family may require several actions.

### Which sources exist in your home?

In addressing the problem of indoor air pollution, you need to think in terms of a specific pollutant, such as formaldehyde or carbon monoxide. You also have to track down the physical source of the pollutant—a furnace or damp crawl space, for example. This chapter cannot cover all possible pollutants and their sources, but it calls attention to the most common types and provides a starting point for investigation and action.

## Part 1a – Combustion byproducts: what precautions are you taking?

**Fuel-burning appliances and equipment.** Airborne combustion byproducts come from oil and gas furnaces; wood and coal stoves; grills; fireplaces; kerosene and gas space heaters; gas ranges, cooktops and water heaters; and automobiles (Figure 1). Pollutants include carbon monoxide, nitrogen and sulfur oxides, formaldehyde and tiny breathable particles. These byproducts should be vented to the outside to prevent accumulation indoors. Never use unvented space heaters, gas stoves or other combustion equipment in an enclosed room. Also, never idle a car in the garage, even if the door to the outside is open. Fumes can build up quickly and enter the living area.

Carbon monoxide (CO), an odorless, colorless gas, is a pollutant of special concern because it is not easily detectable and can kill. Symptoms of exposure such as headaches, dizziness and nausea may be mistaken for other causes. A malfunctioning furnace or blocked flue pipe can result in fatal CO levels. Another dangerous source of CO is a charcoal grill used indoors.

CO detectors (alarms) look like smoke detectors. Some experts recommend that CO detectors that meet Underwriters Laboratories (UL) Standard 2034 or International Approval Services (IAS) 6-96 standard be installed in all homes that have combustion appliances. CO is lighter than air and readily disperses. It's important to place the detector according to manufacture's directions. If only one detector is to be used, then it should be placed near the master bedroom. Additional locations include hallways outside other bedrooms, the living room, main hallway or other rooms where people spend most of their time and can hear the alarm. CO detectors should be considered a backup, not a replacement for proper use and maintenance of fuel-burning appliances.

To determine the safety of your combustion appliances, call the dealer or a service professional for expert assistance. Yearly inspection of the equipment and chimney or flue is recommended for most heating systems. Like your car, your furnace needs cleaning and tune-ups to stay in good condition. Even a well-running system can become a hazard if the chimney or flue becomes blocked and gases cannot escape.

In addition, be alert for backdrafting. This occurs when the indoor air pressure is lower than the outdoor air pressure—this causes combustion gases to be pulled back into the living space instead of being fully exhausted to the outside. Backdrafting is more likely in well-sealed, energy-efficient homes, especially when exhaust fans are in use.

**Tobacco smoking.** The smoke from cigarettes, cigars and pipes contains a wide range of throat and lung irritants, as well as hazardous and cancer-causing chemicals. A smoky home environment puts everyone at risk, not just the smoker.

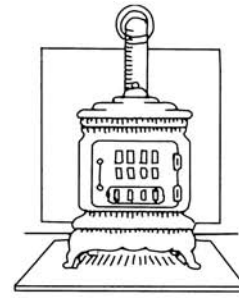

Wood or coal stove

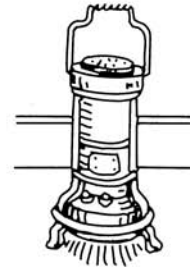

Portable kerosene heater



Gas range

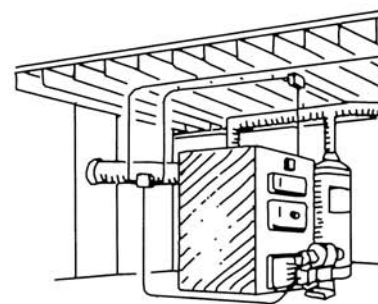

Gas furnace or water heater

Figure 1: Examples of fuel-burning appliances and devices that may be present in a home.

## ✓ Assessment 1a – Combustion Byproducts

Use the assessment below to rate your risks related to combustion byproducts. For each question, indicate your risk level (low, medium or high) in the right-hand column. Although some choices may not correspond to your situation, choose the response that best fits.

	<b>Low risk/ recommended</b>	<b>Medium risk/ potential hazard</b>	<b>High risk/ unsafe situation</b>	<b>Your risk</b>
<b>Combustion appliances, venting</b>	All combustion appliances are vented directly to the outside.	Unvented gas or kerosene heaters are used only in open spaces with a partially open window.	Kerosene or gas space heaters are frequently used in closed rooms. Not all combustion appliances are vented outdoors.	
<b>Maintenance of combustion appliances, chimneys and flues</b>	Chimneys, flues, gas/oil furnaces, woodstoves and other combustion appliances are inspected and cleaned at least once a year.	Chimneys, flues, gas/oil furnaces, woodstoves and other combustion appliances have been inspected only once or twice in the past five years.	Chimneys, flues and combustion devices are not inspected, or the inspection record is unknown.	
<b>Carbon monoxide detectors (only in homes with combustion appliances)</b>	A UL 2034 or IAS 6-96 standard carbon monoxide detector is installed and the battery is tested regularly (if applicable).	A non-UL 2034 or non-IAS 6-96 standard detector is installed and/or the battery is not tested regularly (if applicable).	A carbon monoxide detector is not installed.	
<b>Tobacco smoking</b>	Tobacco smoking is not permitted in the home.	Smoking is permitted occasionally, but only in areas well-ventilated to the outside.	Frequent smoking causes smoky indoor air.	
<b>A boxed risk level</b> indicates level required for Residential Environmental Assurance Program certification.				

### Responding to risks

Your goal is to lower your risks. Turn to the Action Checklist at the end of the chapter to record the medium and high risks you identified. Use the information in this chapter to help you make plans to reduce your risks.

## Part 1b – Which building materials, wood finishes and home furnishings might be affecting your indoor air?

Many products used to build and furnish a home can pollute indoor air. Four of the most common types are discussed here: pressed wood products; carpet; paint, varnishes and other surface finishes; and asbestos. Especially when some of these materials are new, they can release hazardous emissions such as formaldehyde and other volatile organic compounds (VOCs) into the air. High temperatures and humidity can worsen the problem. Air pollutants can also come from old or deteriorating materials, such as asbestos.

**Pressed wood products.** Pressed or manufactured wood products made from wood chips or sawdust are widely used in home construction for flooring, sheathing, shelving and cabinets. Furniture, too, is often made of manufactured wood products. The primary concern with pressed wood is formaldehyde, which is used in the glues that holds these materials together. Formaldehyde will off-gas, or be released into the air, especially when a product is new. Some individuals are very sensitive to formaldehyde.

Sealing the surface of a wood product, especially the edges, will reduce formaldehyde emissions. Manufactured wood products that are formaldehyde-free or have low formaldehyde emissions (such as exterior-grade products) are available.

**Carpet.** New carpets can release volatile chemicals from carpet backing, padding and fibers, as well as from the finishes that give carpeting its antistatic and soil-release properties, and the adhesives for installing the carpet. The carpet industry is working to reduce these emissions; the Carpet and Rug Institute (CRI) now tests carpets for emissions (Figure 2).

**INDOOR AIR QUALITY CONSUMER INFORMATION**

**IMPORTANT HEALTH INFORMATION:**  
SOME PEOPLE EXPERIENCE ALLERGIC OR FLU-LIKE SYMPTOMS, HEADACHES, OR RESPIRATORY PROBLEMS WHICH THEY ASSOCIATE WITH THE INSTALLATION, CLEANING, OR REMOVAL OF CARPET OR OTHER INTERIOR RENOVATION MATERIALS. IF THESE OR OTHER SYMPTOMS OCCUR, NOTIFY YOUR PHYSICIAN OF THE SYMPTOMS AND ALL MATERIALS INVOLVED.

**INSTALLATION GUIDELINES:**

- VACUUM OLD CARPET BEFORE REMOVAL
- VACUUM FLOOR AFTER CARPET AND PAD HAVE BEEN REMOVED
- ALWAYS VENTILATE WITH FRESH AIR (OPEN DOORS AND/OR WINDOWS, USE EXHAUST FANS, ETC.) DURING ALL PHASES OF INSTALLATION AND FOR AT LEAST 72 HOURS THEREAFTER.
- IF ADHESIVES AND/OR PAD ARE USED, REQUEST THOSE WHICH HAVE LOW CHEMICAL EMISSIONS
- FOLLOW DETAILED INSTALLATION GUIDELINES FROM MANUFACTURER OR FROM CARPET AND RUG INSTITUTE

**SENSITIVE MATERIALS**  
PERSONS WHO ARE ALLERGY-PRONE OR SENSITIVE TO ODORS OR CHEMICALS SHOULD AVOID THE AREA OR LEAVE THE PREMISES WHEN THESE MATERIALS ARE BEING INSTALLED OR REMOVED.

**NOTE:**  
YOU CAN REDUCE YOUR EXPOSURE TO MOST CHEMICAL EMISSIONS WHEN CARPET AND OTHER INTERIOR RENOVATING MATERIALS ARE INSTALLED, CLEANED, OR REMOVED BY INCREASING THE AMOUNT OF FRESH AIR VENTILATION FOR AT LEAST 72 HOURS. (See Installation and Maintenance Guidelines or ask for Owner's Manual.)

The manufacturer of this carpet participates in a program which seeks to develop ways to reduce emissions by testing samples of carpet. With fresh air ventilation, most carpet emissions are substantially reduced within 48-72 hours after installation.



FOR MORE INFORMATION: CARPET AND RUG INSTITUTE 800/882-8846

Figure 2: Carpet and Rug Institute (CRI) labels appear on carpets tested for low emissions.

### Planning to install a new carpet?

For better air quality, try to:

- ✓ Choose a carpet that is certified by the CRI as a low-emissions carpet.
- ✓ Ask the carpet dealer to unroll the carpet and leave it in a well-ventilated area for at least 24 hours before it is brought to your home.
- ✓ Plan to install the carpet at a time of year when you can provide extra ventilation by opening windows during and for several days after installation.
- ✓ Arrange for chemically sensitive persons to be out of the house for a few days after the carpet is installed.
- ✓ Thoroughly vacuum the old carpet before removal and the floor after carpet removal to minimize dust and biological pollutants in the air.

Carpets of any age can act as a trap or sponge for chemical and biological pollutants that are carried in the air or tracked in from outside. Damp, dirty carpet is a breeding ground for biological pollutants. Carpets require regular vacuuming and cleaning.

**Paint, varnish and other surface finishes.** Products used to finish, protect, and beautify materials in the home are potential sources of indoor air pollutants because they contain volatile organic compounds (VOCs). These products have strong odors. Products that are oil-, solvent- or alkyd-based release more harmful vapors than water-based products. If you are not sure about a particular product, check the product label. If the instructions on the label say to clean up with soap and water, then the product is water-based.

Select low-VOC products. Provide lots of extra ventilation when finishes are newly applied, or apply finishes outside the home and wait until they are dry to bring the finished product inside.



Lead, a highly toxic substance, was once a common ingredient in household paint. Many homes still have lead-based paint. Lead dust can be released into the air as the paint wears or during renovations. See Chapter 4, “Lead In and Around the Home,” for more information.

**Asbestos.** Until about 1980, asbestos was widely used in building materials to give strength, increase heat insulation and provide fire resistance. It was used in roof and siding shingles, floor tiles, soundproofing materials, insulation around furnace pipes, heating ducts and flues, and decorative finishes (Figure 3). When asbestos products get old, they can become crumbly and disperse tiny fibers into the air. If you breathe asbestos particles over time, they can accumulate in your lungs and lead to serious respiratory problems as well as cancer.

Usually it is best to leave asbestos material that is in good condition alone. If possible, prevent it from being damaged, disturbed or contacted. Periodically check for damage or wear. Get rid of damaged or worn asbestos gloves, stove top pads or ironing board covers. Check with your local health department or the Department of Environmental Quality on landfills that accept asbestos. If you need to remove asbestos, call a professional. For listings, go to the Michigan Clean Air Consultant Directory website at [www.michigan.gov/deq](http://www.michigan.gov/deq) and enter “clean air consultant” in the search bar.

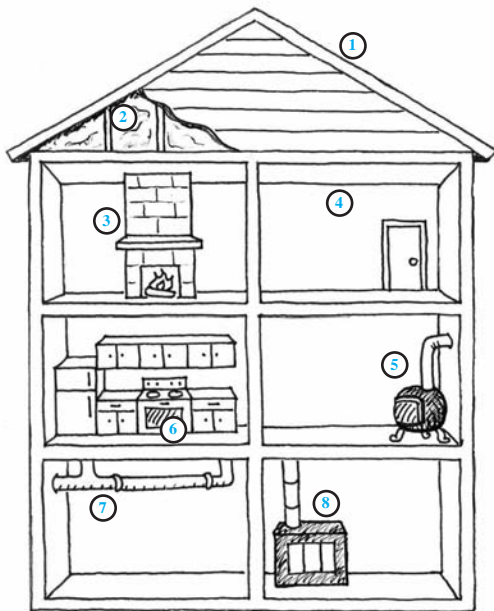

1. Roof coverings
2. Attic insulation
3. Fireplace insulation
4. Wall/ceiling plasters
5. Wood stoves
6. Oven insulation
7. Pipe insulation
8. Boiler insulation

Figure 3: Examples of possible asbestos hazards in the home.

## ✓ Assessment 1b – Building Products and Furnishings

Use the assessment below to identify risks related to building product emissions and asbestos. For each question, indicate your risk level in the right-hand column. Although some choices may not correspond exactly to your situation, choose the response that best fits.

	<b>Low risk/ recommended</b>	<b>Medium risk/ potential hazard</b>	<b>High risk/ unsafe situation</b>	<b>Your risk</b>
<b>New building materials, paints, varnishes and furnishings</b>	Low- or no-emission furnishings, building materials, paints and varnishes are selected. New items are given adequate ventilation or sealed.	New furnishings, building materials, paints and varnishes are given increased ventilation.	There is no attempt to select low-emission products, and ventilation is inadequate.	
<b>Carpet</b>	Low-VOC carpet is selected and aired before and during installation. Carpet is vacuumed regularly using a vacuum cleaner with a high-efficiency filter; spills are cleaned immediately.	New carpet is installed without ventilation. Carpet is maintained with regular vacuuming and rapid spill cleanup.	Old high VOC carpet is poorly maintained.	
<b>Asbestos (in homes built before the 1980s)</b>	Asbestos is present but safely encased and isolated. Areas with asbestos are checked periodically.	Asbestos is present and intact but located in high-traffic areas.	Asbestos-containing material is in poor shape and crumbling. People are exposed to the dust and fibers.	
<b>A boxed risk level</b> indicates level required for Residential Environmental Assurance Program certification.				

### Responding to risks

Your goal is to lower your risks. Turn to the Action Checklist at the end of the chapter to record the medium and high risks you identified. Use the information above to help you make plans to reduce your risks.

### Part 1c - Biological contaminants: how do they affect indoor air?

Your house is home to many organisms. Some are wanted, such as pets, but many are uninvited. Biological contaminants come from living or once-living organisms. They include animal hair, dander, saliva and feces; molds; dust mites; insect residues; pollen; and microscopic organisms. These can cause odors, damage household materials, lead to allergic reactions, and cause infectious diseases and respiratory problems. Sensitivity to these contaminants varies from person to person.

#### Tips for controlling moisture in the home

- ✓ Prevent standing water in places such as basements or the drip pans of refrigerators and air conditioners.
- ✓ Fix leaks and seepage problems immediately.
- ✓ Make sure rainwater drains away from your house.
- ✓ Use a vaporproof ground cover (such as 4- to 6-mil plastic) in enclosed crawl spaces.
- ✓ Use fans that exhaust to the outside when bathing, showering or cooking.
- ✓ Vent all combustion appliances to the outside.
- ✓ Use dehumidifiers and/or air conditioners to remove excess moisture in warm weather.
- ✓ Avoid oversized air conditioners.
- ✓ Limit the use of humidifiers.
- ✓ Limit houseplants.





Figure 4: Dust mite, a microscopic animal related to spiders and ticks. *U.S. National Library of Medicine - National Institutes of Health*



Biological pollutants are found in every home and cannot be eliminated completely. Their growth and quantities can be controlled, however, by keeping surfaces clean and moisture levels low (see p. 54). Biological contaminants such as bacteria, molds (fungi) and some insects will increase in damp or humid spaces. Good maintenance practices can control moisture and reduce the need for chemical products such as pesticides and disinfectants, both of which could add other pollutants to the air.

**Dust control.** Household dust includes some biological contaminants that are common allergens. Animal dander is shed from skin, hair or feathers. Dust mites (Figure 4) and their feces—the primary allergen—are easily airborne. Regular cleaning, including dusting with a treated cloth, damp cleaning and laundering bedding with hot water, as well as placing pillows and mattresses in plastic casings, are needed to control these contaminants.

Regular vacuum cleaning may help control dust, but some particles are so small that they pass through cleaner filters and become airborne. Some vacuum cleaners have high-efficiency particulate air (HEPA) filters to retain more small particles instead of recirculating them back into the air.

If dust-related allergies are a particular problem, limit the use of carpeting, upholstered furnishings and “dust catchers” such as window blinds and knick-knack displays. Follow recommended procedures for dust control, and keep sleeping areas as allergen-free as possible.

### ✓ Assessment 1c – Biological Contaminants

Use the assessment below to identify risks related to air pollution from biological sources. For each question, indicate your risk level in the right-hand column. Although some choices may not correspond exactly to your situation, choose the response that best fits.

	Low risk/ recommended	Medium risk/ potential hazard	High risk/ unsafe situation	Your risk
<b>Dust control</b>	House is cleaned regularly. No furry pets are kept in the home. Little or no carpeting is in the home.	Furry pets live in the home, but the house is cleaned regularly.	Pet hair and dust are allowed to accumulate in living and sleeping areas. House is mostly carpeted, and carpet is poorly maintained.	
<b>Moisture control</b>	There is no evidence of condensation in high-moisture areas or seasonally. Excess moisture is vented to the outside.	There is evidence of condensation in high-moisture areas or seasonally. Exhaust fans or dehumidifiers are sometimes used.	Damp air is not exhausted. Crawl space does not have a ground cover or vents. There are leaks, drips or standing water in, around or under the house. Basement has high moisture during summer and/or moisture due to drainage problems. Dehumidifier not used.	
<b>A boxed risk level</b> indicates level required for Residential Environmental Assurance Program certification.				

### Responding to risks

Your goal is to lower your risks. Turn to the Action Checklist at the end of the chapter to record the medium and high risks you identified. Use the information above to help you make plans to reduce your risks.

## Part 1d – Household chemical products, pesticides, radon and methane

### Household chemical products: what types of air quality problems do they cause?

You may use a variety of potentially hazardous chemical products in your home for maintenance, cleaning, personal grooming and hobbies. Some products, such as those in spray cans, can release chemicals or particles into the air during use. Others emit chemicals as the product dries or cures (such as glues and caulking) or from off-gassing as the product ages (plastics and air fresheners, for example). Potentially hazardous products include furniture waxes, paint strippers, adhesives, some cleaning products, disinfectants, degreasers, cosmetics, pesticides and hobby supplies.

Products having volatile petroleum materials (gas, lighter fluid, paint stripper, nail polish remover) or other volatile organic compounds create more unhealthy emissions than water-based products. Many everyday household products such as chlorine bleach, ammonia, boric acid and deodorizers may generate indoor air pollutants if used improperly. Some household products contain pesticides and other toxic chemicals and require special precautions. See Chapter 3, “Managing Hazardous Household Products,” for more on this topic.

**Reducing the hazard from household products.** Choose the least hazardous product and the smallest amount that will do the job. Always follow the label directions and provide adequate ventilation (Figure 5). To avoid having to store hazardous products, buy only the amount you will need, then use it up. Give away leftovers or properly dispose of household chemicals that are not needed. You can reduce the need for many household chemicals by practicing preventive maintenance, such as giving quick attention to spills and stains or promptly removing food wastes to control odors and pests.

### Pesticides: are they in your home?

Pesticides are chemicals that kill or repel pests. Fungicides (for molds), bactericides (for bacteria), insecticides (for insects) and rodenticides (for rodents) are commonly used in and around the home. According to the Environmental Protection Agency information, 75 percent of U.S. households used at least one pesticide product indoors during the year reviewed. They also state that 80 percent of most people’s exposure to pesticides occurs indoors. Up to a dozen pesticides have been measured in the air in homes. In addition to homeowner indoor pesticide usage, this may also be due to soil and dust tracked in, or releases from treated surfaces and stored pesticides.

Pesticide products are available as pump sprays, aerosol sprays, foggers, liquids, granules, powders, baits, pesticide-impregnated material (pet collars and pest strips), sticks, crystals and balls. Various pesticides last for different lengths of time. Highly persistent pesticides last for a long time. This can be a problem in the home. Exposure to high levels of pesticides is generally due to misapplication of the product. Reading the label before purchase and again before use is important for proper selection and application. The label is the law.



Figure 5: Provide adequate ventilation when using hazardous household products.



Before selecting a pesticide, consider the pest control options and level of the pest problem. For example, one fly would not merit pesticide use. A fly swatter would be a far better choice. Choose the option that also takes environmental and health risks into consideration (see Chapter 9).

Mothballs and moth crystals, which contain paradichlorobenzene, are commonly used in the bedroom storage area. These solid products volatilize, and the vapor can move through plastic bags into the room air. Some solid air fresheners also contain the chemical. Paradichlorobenzene is known to cause cancer in animals; less is known about its human effects.

After any pesticide use, the area should be well-ventilated. If you have pesticides that you don't plan to use or that are no longer usable, take them to the local Clean Sweep pesticide collection day. Call your local resource recovery or hazardous waste collection site, Michigan State University (MSU) Extension or county conservation district office, or see "Resources" at the end of this chapter for the Clean Sweep website.

### **Methane: is it present in your home?**

Methane is an odorless, colorless, flammable gas. It is formed by the decay of natural materials and is common in landfills, marshes, septic systems and sewers. Methane at levels as low as 5 percent can form an explosive mixture with air. Pockets of methane may be found naturally underground and seep into your basement. It may enter by sewer lines or through cracks in the foundation.

If methane is suspected, call your local health department. If there is a smell of sewer gases in your home, call a plumber or other qualified person to identify the source and correct it. If the odor is strong, evacuate the building until the problem is corrected and the gas is removed.

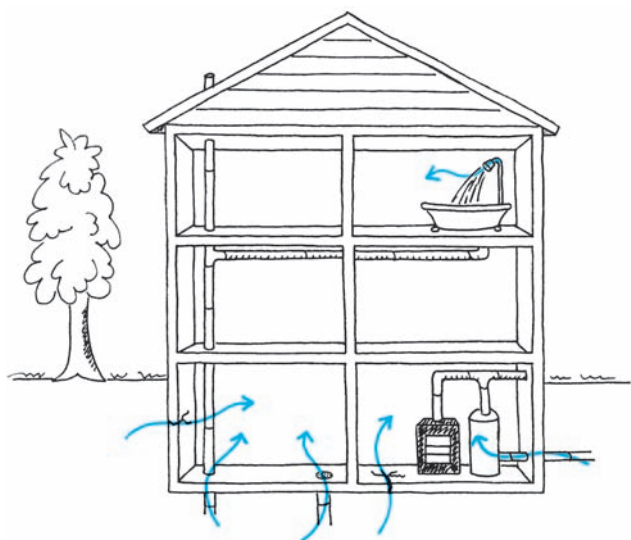

Figure 6: Radon gas may enter a home through openings in contact with the ground and in household water.

### **Radon: is it present in your home?**

Radon is a naturally occurring radioactive gas found in many types of soil and rock. It enters homes through cracks and openings in the foundation, floor or walls that are in contact with the ground (Figure 6). Radon is invisible, has no odor, and causes no immediate symptoms or health effects. It is, however, a cause of lung cancer. Smokers are especially at risk if radon is present.

Various parts of the country have different levels of radon. Even if you don't live in a high-risk area for radon, you should take this potential threat seriously. Radon levels can vary from home to home even within the same neighborhood, and the only way to find out about radon in your home is by testing your home. The generally recommended level of radon in the United States is below 4 picoCuries per liter (pCi/L) of air.

**Radon testing and treatment.** Look for radon test kits that say “meets EPA requirements.” An inexpensive screening test that lasts four to seven days and costs \$10 to \$15 can give a rough idea of how much radon is present. Your local health department may have them for purchase. The test should be conducted when windows and doors are closed. If a high level of radon is found (higher than 8 pCi/l), a second short-term test is recommended to verify the problem. If the initial result was between 4 pCi/l and 8 pCi/l, a long-term test can be done to provide the annual average exposure.

If an unsafe level of radon is verified by the second test, there are a variety of things you can do to reduce radon. These involve either plugging the leaks—such as caulking cracks in basement walls—or changing the ventilation patterns of your home so that radon isn’t drawn inside. Check with the indoor radon specialist, Michigan Department of Environmental Quality, at 1-800-732-6642, or your local health department, MSU Extension or local contractors for advice. A trained and certified radon mitigator can be invaluable in helping you reduce radon in your home.

### ✓ Assessment 1d – Household Products, Methane and Radon

Use the assessment below to identify risks related to household chemical products and radon. For each question, indicate your risk level in the right-hand column. Although some choices may not correspond exactly to your situation, choose the response that best fits.

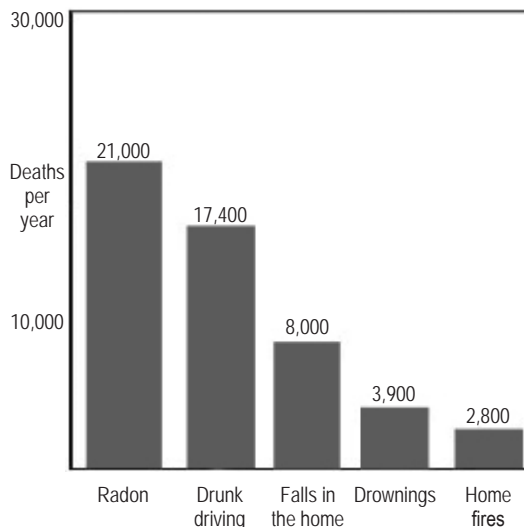

Figure 7: Radon is estimated to cause about 21,000 lung cancer deaths per year, according to the EPA’s 2003 Assessment of Risks from Radon in Homes (EPA 402-R-03-003). The numbers of deaths from other causes are taken from the Centers for Disease Control and Prevention’s 1999-2001 National Center for Injury Prevention and Control Report and 2002 National Safety Council Reports.

	Low risk/ recommended	Medium risk/ potential hazard	High risk/ unsafe situation	Your risk
<b>Household products and chemicals</b>	Products with hazardous vapors are avoided or used only outdoors or indoors with proper ventilation and safety precautions. Hazardous products are stored according to the labels.	Products with hazardous vapors are used indoors with some ventilation. Only short periods of exposure occur.	Products with hazardous vapors are used indoors without ventilation. Long periods of exposure occur. Hazardous products are not stored according to labels.	
<b>Methane</b>	No smell of sewer gases. No history of coal or marsh gases in area. No cracks in basement walls.		Smell of sewer gases or history of marsh or coal gases collecting in area.	
<b>Radon</b>	A radon test was conducted properly, and the radon level is below the threshold for action.	Radon is present at or near the threshold for action.	Radon is present in excess of acceptable levels, OR, radon level is unknown; no testing has been done.	

**A boxed risk level** indicates level required for Residential Environmental Assurance Program certification.

### Responding to risks

Your goal is to lower your risks. Turn to the Action Checklist at the end of the chapter to record the medium and high risks you identified. Use the information above to help you make plans to reduce your risks.



## Part 2 – Ventilating Indoor Air

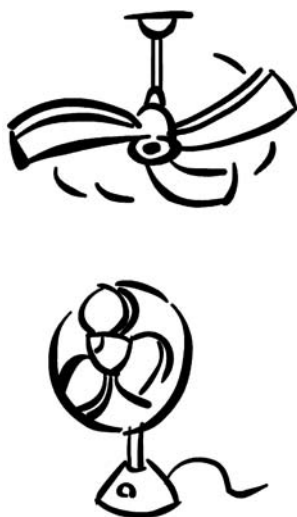

Figure 8: Fans can help to move air in the home.

The removal or reduction of pollution sources is the first priority in improving the air quality in your home. The second priority is to dilute the concentration of air pollutants through increased ventilation of the home.

Even in homes with few sources of contamination, ventilation is needed, especially during seasons when windows and doors are kept shut. Many homes “leak” air, which may help maintain freshness but wastes energy. Newer homes tend to have tighter construction, which makes it easier for pollutants to build up to dangerous levels. Tight homes may also be susceptible to humidity problems.

### How well is your house ventilated?

Use your nose and eyes to help evaluate indoor air quality. Be aware of persistent odors of chemicals, mildew or tobacco smoke. Steamy windows in cool weather indicate high levels of moisture in the home. (See “Tips for controlling moisture in the home” on page 54.) Lingering odors of grease and food may mean that your kitchen needs more ventilation.

Home ventilation is usually measured in air changes per hour (ACH). This is a measure of how many times per hour the volume of air in your home is replaced with outdoor air. Many factors can affect the ACH rate, including the structure of the home; weather; opening or closing of doors and windows; heating, cooling and ventilating equipment; and use of fans (Figure 8).

A blower door test administered by a professional is needed to adequately measure ventilation rates in your home. A blower door consists of a large fan mounted in a frame that is temporarily installed in an outside doorway. The fan forces air into or out of the home. Pressure readings obtained from the test help in calculating air leakage and the ACH rate. The test can also help determine where leakage is occurring.

Increasing the ventilation rate of your home will reduce the concentration of air pollutants. Exhaust fans in kitchens and bathrooms are helpful, as long as adequate replacement air is available. Some ventilation equipment can increase ventilation while conserving energy. For example, a heat recovery ventilator removes stale air from a house and brings in fresh air. The incoming air is warmed by heat removed from the outgoing air. If you suspect the ventilation in your home is inadequate, consult an energy professional.

### What about air filters and air cleaners?

Air filters in your heating/cooling air circulation system need to be inspected regularly and replaced or cleaned when dirty. Dirty or clogged filters will limit the efficiency of the equipment. Standard air filters on heating and cooling equipment will remove only the largest dust particles. Other high-efficiency filters are more effective and will remove particles such as dust, smoke, pollen and some microorganisms. Gases will generally go right through air filters.

There are several types of air cleaners that clean the air in different ways. Mechanical filters are made of fibers or pleated filter papers that trap small particles as air passes through. Electrostatic air cleaners use an electrical field to attract charged airborne particles; ion generators are used to give particles a charge that makes them stick to surfaces in the home. Solid sorbent cleaners—such as activated carbon or charcoal—can capture gaseous pollutants.

**Note:**

Remember that air filters and cleaners are of limited use in solving indoor air quality problems. If poorly maintained, they could actually contribute to your air quality problems. The effectiveness of filters and cleaners depends on several things:

- ✓ The contaminants removed from the air.
- ✓ How much air passes through the device.
- ✓ The kinds of airborne particles in your air.
- ✓ Where the unit is located in relation to the pollutant sources.
- ✓ Regular maintenance of the system.

## ✓ Assessment 2 – Ventilating Indoor Air

Complete the assessment below to identify risks related to air freshness. For each question, indicate your risk level in the right-hand column. Although some choices may not correspond exactly to your situation, choose the response that best fits.

	<b>Low risk/ recommended</b>	<b>Medium risk/ potential hazard</b>	<b>High risk/ unsafe situation</b>	<b>Your risk</b>
<b>Air freshness</b>	Indoor air usually smells clean, in all seasons. Extra ventilation is provided as needed.	Air sometimes has an odor or mustiness, especially during certain times of the year.	Air nearly always smells musty, damp, acrid, smoky, heavy or like “chemicals.”	
<b>Ventilation</b>	House is well-ventilated. Exhaust fans are used in the kitchen and bathroom.	“Leaky” house gives some uncontrolled ventilation.	House is poorly ventilated. No kitchen/bath exhaust fans are used.	

### Responding to risks

Your goal is to lower your risks. Turn to the Action Checklist on the following page to record the medium and high risks you identified. Use the recommendations above to help you make plans to reduce your risks.



## ✓ Action Checklist

Go back over the assessments and look for the high and medium risks you identified. Record them below. For each medium and high risk listed, write down the improvements you plan to make. Use recommendations from this chapter and other resources to decide on an action you are likely to complete. A target date will keep you on schedule. You don't have to do everything at once, but try to eliminate the most serious risks as soon as you can. Often it helps to tackle the inexpensive actions first.

Write all high and medium risks here.	What can you do to reduce the risk?	Target date for action:
Example: House not tested for radon.	Call health department to see if they sell tests. Conduct test.	One week from today: September 1

## Resources

### Publications

**“The Inside Story: A Guide to Indoor Air Quality,”** a 36-page illustrated publication by the U.S. Environmental Protection Agency. Identifies problems and control methods for indoor air pollutants including radon, tobacco smoke, lead and household products. Indoor Air Quality Information Clearinghouse (see “General” information on the next page). Available online at [www.epa.gov/iaq/pubs/insidest.html](http://www.epa.gov/iaq/pubs/insidest.html).

### **A Brief Guide to Mold, Moisture and Your Home**

1200 Pennsylvania Ave, Mail Code 6609J  
Washington, DC 20460  
[www.epa.gov/iaq](http://www.epa.gov/iaq)

**Asbestos** - [www.epa.gov/asbestos](http://www.epa.gov/asbestos)

**Carbon Monoxide** - [www.michigan.gov/carbonmonoxide](http://www.michigan.gov/carbonmonoxide)

## Pesticides

Michigan unwanted pesticide collection sites (Clean Sweep sites):

[www.michigan.gov/mda](http://www.michigan.gov/mda)

Enter “Clean Sweep” in search bar, click “MDA - Clean Sweep,” then click “Clean Sweep Contact Information by County.”

National Pesticide Information Center

Phone: 1-800-858-7378

<http://npic.orst.edu>

Contact for pesticide answers and some EPA publications.

## Radon

- [www.michigan.gov/deqradon](http://www.michigan.gov/deqradon) 1-800-RadonGas / 1-800-723-6642

- [www.epa.gov/radon/pubs](http://www.epa.gov/radon/pubs)

“Home Buyer’s and Seller’s Guide to Radon”

“Consumer’s Guide to Radon Reduction”

“A Citizen’s Guide to Radon: the guide to protecting yourself & your family from radon”

- [www.michigan.gov/deq](http://www.michigan.gov/deq)

Enter “Clean Air Consultant Directory” in search bar.

## Radon testing

Check the test kits at hardware and building supply stores, or contact your local or state health department or the Department of Environmental Quality, MSU Extension office or private testing laboratories. Recorded information about radon is available 24 hours a day from the National Radon Hotline.

Call 1-800-SOS-RADON.

## General

Indoor Air Quality Information Clearinghouse (IAQ INFO)

P.O. Box 37133

Washington, DC 20013-7133

Phone: 1-800-438-4318, Monday-Friday, 9 a.m. - 5 p.m. (EST)

[www.epa.gov/iaq/iaqxline.html](http://www.epa.gov/iaq/iaqxline.html)

Ask for the list of currently available documents.

Clean Air Control

135 South 19th Street

Philadelphia, PA 19103

Phone: 215-567-4004

Contact for information on services and testing procedures.

American Lung Association

Call your local organization or call 1-800-LUNG-USA (toll-free).

[www.lungusa.com](http://www.lungusa.com)

Carpet and Rug Institute, Indoor Air Quality Testing Program

P.O. Box 2048

Dalton, GA 30722-2048

1-800-882-8846 (toll-free) or 706-278-3176

[www.carpet-rug.com](http://www.carpet-rug.com)

This Home\*A\*Syst chapter covers a variety of topics to help homeowners examine and address their most important environmental concerns. For more information on topics covered in Home\*A\*Syst or for information about laws and regulations specific to your area, contact your local MSU Extension office.

This chapter was written by Kathleen Parrott, associate professor and Extension housing specialist, Virginia Polytechnic Institute and State University, and adapted for Michigan in 2008 by Roberta Dow, Michigan State University Extension.







This chapter helps you identify possible problems with your home heating and cooling systems, your house envelope (the foundation, floors, walls, ceilings and roof), as well as the surrounding landscape. By keeping your home systems and surrounding environment in proper order, you can avoid unhealthy situations, reduce energy bills, increase your comfort level and prevent structural damage. This chapter covers:

**1. Energy efficiency**

- ◆ Heating/cooling
- ◆ Air-sealing and insulation
- ◆ Domestic hot water, lighting systems and appliances

**2. Landscaping for energy conservation**



# Chapter 6. Energy Savings for your Home

## Why should you be concerned?

Your house should be a safe, comfortable place that is affordable and durable. How a home is constructed, insulated and heated/cooled directly affects how it meets these objectives. A house is affordable only when costs for heating and cooling are reasonable. Energy bills are lowest if a home is air-sealed and properly insulated and if all mechanical systems are operating efficiently. Before extensively air-sealing your home, it is critical to ensure that doing so will not cause health or moisture problems. (For combustion appliance issues, please see Chapter 5, “Indoor Air Quality.”) Also, landscaping can be a significant factor in energy conservation for a home. Above all else, your home must be a healthy place to live.

## Energy consumption

The amount of energy consumed in your home depends on many factors, including how well the home is insulated, the efficiency of appliances, the local weather and climate, the landscaping surrounding your home and your lifestyle.

## Does your house use too much energy?

Figure 1 shows how energy is used in a typical home. Your family’s lifestyle will affect how energy is consumed in your home.

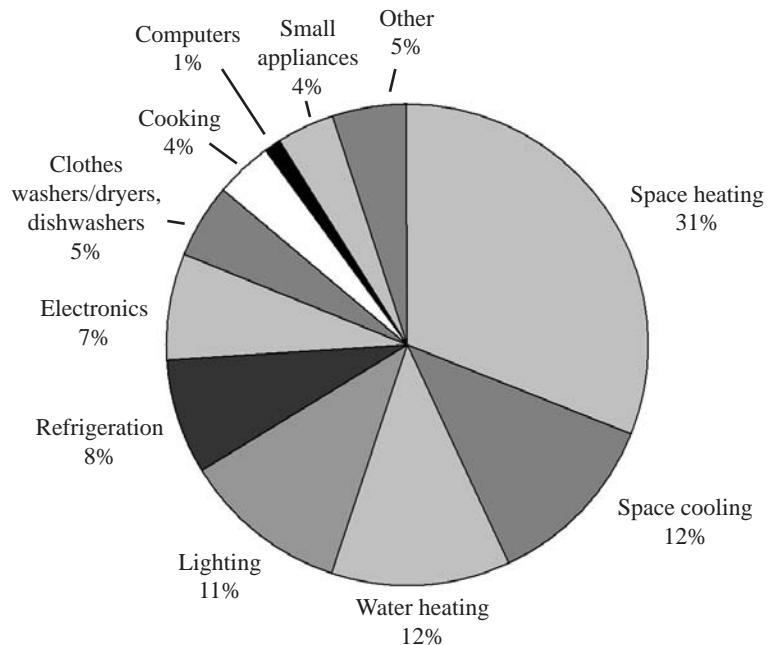

Figure 1: Residential energy consumption. *Building Energy Data Books, 2007.*

The best and most accurate way to determine the energy efficiency of your home is to have a home energy audit performed by a service professional. Not only will the audit pinpoint high energy areas, but it will also suggest measures for cutting your energy costs. If you are unable to have a professional audit, consider doing a self-survey. Self-survey tools are available on the web (see “Resources” at the end of this chapter). After conducting your survey, make improvements to increase your energy efficiency and home comfort if they make economic sense for your situation.

## Part 1 – Energy efficiency inside the Home

The three key strategies to increase energy efficiency are air-sealing (leak-proofing) your home, adding insulation and efficient windows, and using more efficient appliances. The average home in the United States wastes 30 to 50 percent of the energy it uses. If every home installed energy-efficient appliances and was well-insulated, individual homeowners and the national economy would reap tremendous savings. The following sections will help you identify where energy is being lost and how you can prevent future losses. Complete the assessments at the end of each section to find out where improvements can be made.

### Part 1a – Improving heating and cooling systems

The single greatest energy consumer in your home is the heating/cooling system (furnace, boiler, heat pump, wood stove and air conditioner—see Figure 1). This system has three parts: heating/cooling unit(s), such as furnaces and air conditioners; ducts or other distribution mechanisms; and a thermostat to control output. You can save energy in all three areas.

#### How old are the parts of your system?

If your primary heating/cooling unit is more than 15 to 25 years old, it is probably not very energy-efficient. Even if it still works, you may benefit by replacing it with a new energy-efficient model. A new device can pay for itself in fuel savings in only a few years. Or, if you find long-term financing for new equipment, the dollar value of the monthly energy savings may exceed the monthly payment for the equipment, which would result in a positive cash flow.

#### Is your system getting proper maintenance?

All machines work more efficiently -- and more safely -- if they are inspected and maintained. Your furnace, air conditioner and other heating/cooling equipment should be checked and serviced every year by a qualified professional. A forced-air system includes an air filter, which removes dust and debris before it reaches the air blower and heat-exchange coils. Dirt on the coils reduces efficiency, so you should change or clean your air filter on a regular basis. Monthly maintenance, such as inspecting and changing air filters, is recommended during the heating or cooling season.

#### Are you using your thermostat to save energy?

One of the easiest ways to save energy is to set thermostats at a lower temperature in the winter and a higher temperature in the summer so that the heating/cooling system runs less often. If a house is caulked and weather-stripped to prevent cold drafts, most people – when dressed appropriately –



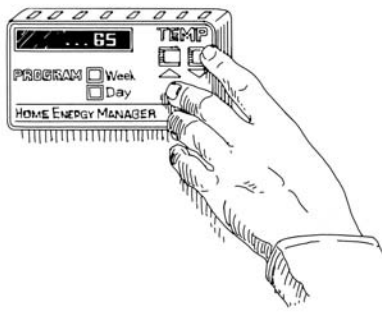

Figure 2: Digital or clock thermostats (programmable) can be set to adjust the temperature automatically.

will be comfortable at 68 degrees Fahrenheit during the winter. To save more energy, temperatures can be turned down to 55 degrees while you are sleeping or when the house is empty. Check with your doctor if you have a medical condition that requires different temperatures. If you have had problems with freezing pipes during very cold weather, correct the problem before turning down the thermostat. During the summer, a thermostat setting of 78 degrees is recommended. During times when the house is unoccupied, a summer thermostat setting of 80 to 85 degrees is recommended. Typically, you'll save 1 to 3 percent on your heating cost for every degree you lower your thermostat for eight hours, or similarly save on your cooling costs by raising the temperature for air conditioning.

Programmable thermostats can be set to adjust the temperature in your house automatically. For example, they can turn the heat down every night at 11 p.m. and bring the temperature back up by 6 a.m. before you get out of bed. The newest kind of residential thermostat, a home energy manager, allows many temperature settings throughout the week. Depending on your lifestyle, a programmable thermostat can pay for itself in as little as one or two years.

### Is your distribution system working well?

Unless there is a heating/cooling unit in each room, you probably have a system to distribute hot or cold air from a central heater or air conditioner. Over 90 percent of central heating systems and virtually 100 percent of central residential cooling systems in America have forced-air distribution systems that use air ducts to move warm (or cold) air to the rooms of the house. If the duct system leaks, it can waste large amounts of energy.

Any ductwork located in an unheated or uncooled space (such as an attic or crawl space) has a high potential for heat or cold air loss. Ducts in such spaces should be insulated. Also, all joints in the duct system, everywhere in the house, should be properly sealed to make sure all of the warm or cool air gets where you want it to go.

Sealing a leaking duct system will reduce the amount of heated or cooled air lost to unconditioned areas and outside air that leaks into the home. Though this will reduce energy consumption, you must also be aware of how it might affect combustion appliances and air quality in your home. The precautions are listed in Chapter 5, "Indoor Air Quality."

In addition to supply registers in each room to deliver heated/cooled air, there must be a return duct to allow air to get back to the heating/cooling unit. Many newer homes do not have a return register in every room but rely on the space under a closed door to allow supply air to return to a centrally located return. If you have a room that is uncomfortable (hard to heat or cool) when the door is shut but is fine when the door is open, you probably have an air distribution problem. You can increase the cut under the door or call a heating and cooling specialist to resolve the problem.

The second most common heat distribution system uses hot water that is distributed through pipes to radiators or convectors. Pipes carrying hot water should be insulated everywhere, from boiler to radiator. Use a quality insulation material. Cheap materials break down more quickly.

#### Safety note

Your home receives outside air from all small holes and cracks in the structure, including any holes in the duct system that are located outside the conditioned space (such as an attic or crawl space). Duct sealing is a job best left to a professional.

## ✓ Assessment 1a – Improving Heating/Cooling Systems

Use the assessment below to identify where energy can be saved. Indicate your energy-loss potential (low, medium or high) in the right-hand column. Although some choices may not correspond exactly to your situation, choose the response that best fits. Refer to the sections above if you need more information to complete the assessment.

	<b>Low energy loss</b>	<b>Medium energy loss</b>	<b>High energy loss</b>	<b>Your loss potential</b>
<b>Age of heating and cooling equipment</b>	Equipment less than 5 years old.	Equipment is 5 to 15 years old.	Equipment is older than 15 years.	
<b>Maintenance of heating and cooling equipment</b>	Air filters are checked every month during use, and cleaned or replaced as needed. Equipment is serviced at least every two years.	Filters are checked and changed occasionally, and the system is maintained on a regular basis.	Filters are not changed or rarely changed, and the system is not maintained.	
<b>Air-temperature thermostat</b>	A programmable thermostat is installed. It is routinely used to minimize energy consumption OR an older thermostat present but temperature adjusted for nighttime or when gone.	A programmable thermostat is installed, but it is not used to modify temperatures at night or when the house is empty.	An older thermostat is in use. It is set to maintain a constant temperature.	
<b>Duct location</b>	All ductwork is located in heated / cooled space.	Some ductwork is located in unheated/uncooled space.	All ductwork is located in unheated space.	
<b>Ductwork in unconditioned space (if applicable)</b>	All ductwork in unheated/uncooled space is insulated.	Some ductwork in unheated/uncooled space is insulated.	All ductwork is located in unheated/uncooled space and uninsulated.	
<b>Return duct</b>	There are air-return ducts in every room OR bedroom doors are left open.	There is one central air return. Bedroom doors are shut at night, but there is a 2 inch or greater space under each door.	There is one central air return. Bedroom doors are shut at night, and there is little space between the bottoms of the doors and the floor.	
<b>Air-sealing ducts and registers</b>	Seams in the duct system are caulked or sealed, especially where air registers enter rooms.	There are no visible gaps in the duct system.	Gaps are visible in the duct system or around the room air registers.	
<b>A boxed risk level</b> indicates level required for Residential Environmental Assurance Program certification.				

### Responding to your energy-loss potential

Your goal is to reduce the amount of wasted energy. Turn to the Action Checklist at the end of this chapter to record the high and medium loss potentials you identified in the assessment. Use the recommendations in Part 1a to help you identify ways to increase energy efficiency.

## Part 1b – Preventing loss of heated (or cooled) air

Once you have reached a comfortable temperature indoors, your aim is to keep it that way. Preventing unwanted air leaks and blocking heat transfer are two important approaches to making your home even more energy efficient.

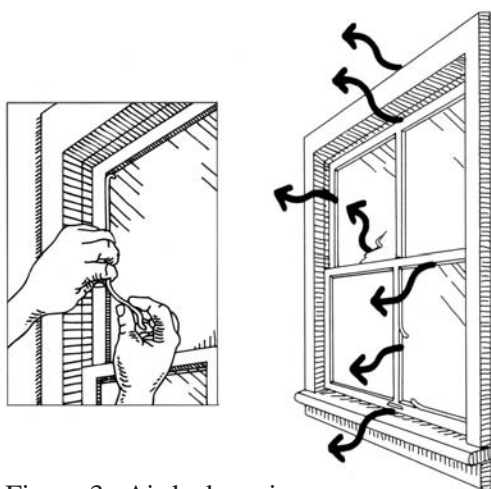

Figure 3: Air leakage is often the primary cause of heat loss from windows and doors. Seal leaks with caulking and weatherstripping.

### Have you air-sealed your home?

Every house has openings through which outside air can enter. Some openings, such as open windows and doors, are obvious air entry sites. Others, such as cracks around window frames, are unintended air pathways (Figure 3). Uncontrolled leakage of air can account for a large portion of the total heat loss in a home—typically about 20 percent of the total heating and cooling bill. Cold (or warm) air entering a home must be heated (or cooled) if the home is to remain comfortable.

Sealing your home against air leakage is not difficult, but it does require specific information to be done right. For details on how to reduce air leaks, contact your local Michigan State University (MSU) Extension office or the U.S. Department of Energy's Energy Efficiency and Renewable Energy (EERE) Information Center (1-877-337-3463), or check out some of the websites listed under "Resources" at the end of this chapter.

#### Safety note

**\*\* Proceed with caution.\*\*** As stated before, your home must be a healthy place to live. Air-sealing can cause a dangerous situation by reducing the air available for combustion appliances. Do not attempt to air-seal your home until you have taken care of these problem areas:

- ◆ Unvented gas or kerosene heaters or unvented gas fireplaces/logs must be removed or vented outdoors.
- ◆ If you have a gas cookstove that is not vented to the outside by a power-vented hood, do not extensively air-seal your home. Alternatively, open a kitchen window 1/4 inch while cooking and run an exhaust fan.
- ◆ If you have a high level of radon in your home, properly air-sealing can help reduce the problem. However, you should monitor radon levels carefully and contact a professional if the problem is not resolved. (See Chapter 5, "Indoor Air Quality," for more information.)
- ◆ If you have natural-draft appliances, such as gas water heaters, some gas stoves and some gas dryers, do not extensively air-seal your home without seeking the advice of an energy services professional.

Remember, a home's energy efficiency depends on a balance between air sealing, insulation, moisture control and ventilation. A proper balance of these will provide a more comfortable, healthy home environment.

### Does your home need more insulation?

Even if you air-seal your house, you still need to prevent the transfer of heat (in or out) through walls, floors or ceilings. Insulation acts like a blanket to retain the heated or cooled air your system produces. Insulation materials are assigned an R-value, which is a measure of how well they resist the flow of heat energy into or out of your home. The larger the R-value, the more heat (or cool air) is kept where you want it.

The recommended amount of insulation for a home varies with geographic locations. If you have extreme temperatures in your part of Michigan, you will need more insulation. Check with your local building supplier. You can also go to the Oak Ridge National Laboratory website for R-value recommendations based on your zip code ([www.ornl.gov/sci/roofs+walls/insulation/ins\\_16.html](http://www.ornl.gov/sci/roofs+walls/insulation/ins_16.html)).

## ✓ Assessment 1b – Preventing Loss of Heated (or Cooled) Air

As before, indicate your energy-loss potential in the right-hand column in the following assessment. Although some choices may not correspond exactly to your situation, choose the response that best fits. Refer to the sections above if you need more information to complete the assessment.

	<b>Low energy loss</b>	<b>Medium energy loss</b>	<b>High energy loss</b>	<b>Your loss potential</b>
<b>Attic</b>	All potential leak points are sealed or weather-stripped.	Only some potential leak points are sealed.	Most potential leak points are not sealed.	
<b>Windows and doors</b>	All windows and doors are sealed with caulk and weather-stripping and tested for leaks. Newer, well-sealed, double-paned windows are installed.	Only some windows and doors are caulked and weather-stripped. Older or leaky storm windows are used. Some windows are sealed in winter with plastic sheets.	Windows are older and not sealed. Storm windows may be absent.	
<b>Basement or crawl space</b>	Rim joists, sill plates, service entrances, windows and wall cracks are sealed with caulk or foam.	Leaks have been detected but are not fully sealed.	No sealing has been attempted.	
<b>Attic insulation</b>	Insulation is equal to or greater than levels recommended for my region.		Insulation is well below the recommended levels OR attic is not insulated.	
<b>Insulation in walls (above-ground)</b>	Exterior wall cavities are insulated with loose fill or 3-inch to 5-inch batt.		There is no insulation in wall cavities.	
<b>Insulation in walls (heated basements)</b>	Exterior walls are insulated with rigid foam or batt, according to the regional recommendations.		Exterior walls and rim joists are not insulated.	

**A boxed risk level** indicates level required for Residential Environmental Assurance Program certification.

## Responding to your energy-loss potential

Your goal is to reduce the amount of energy you use. On the Action Checklist at the end of the chapter, record the high and medium loss potentials you identified above. Use the recommendations in Part 1b to help you find ways to increase energy efficiency.

## Part 1c – Increasing efficiency of domestic water heaters, lighting and home appliances

### Water heaters

After heating and cooling your home, heating water for domestic consumption is the next largest energy user. There are several ways to reduce the amount of energy you use to heat water.

The simplest thing you can do to save energy used for water heating is to turn down the water heater temperature. Each 10-degree reduction in water heater temperature will save you 3 to 5 percent on your annual water heating bill. Lowering the water temperature will also increase the lifetime of your water heater and reduce the risk of someone being burned by the hot water. Children and elderly persons are most at risk of being scalded by water that is too hot.

Most water heaters are factory set around 140 degrees Fahrenheit. For most household uses, that is higher than necessary. Usually, 120-degree water is adequate unless you have an automatic dishwasher without a temperature booster. In this case, you may need to keep the temperature at 140 degrees for optimal dishwashing performance.

Wrapping your water heater with insulation can reduce heating energy use by 4 to 9 percent. Except for some new water heaters that come with high levels of foam insulation and do not need any more, the addition of insulation usually pays for itself in less than one year. Water heater insulation blankets are widely available at hardware and home improvement stores. They come in standard sizes to fit 40-, 60- and 80-gallon water heaters. Be sure to follow the manufacturer's instructions for the installation.

Reducing hot water use will reduce the amount of energy needed. Repair any leaking pipes and consider installing low-flow shower heads. Washing laundry in cold rather than hot water will also save energy.

Hot water pipes should be insulated wherever they are accessible. Either preformed foam insulation or wrap-around fiberglass insulation can be used.

### Lighting

Lighting accounts for 11 percent of a typical home energy budget. Turning off unused lights and making improvements to lighting can easily and quickly cut your energy costs. Use compact fluorescent lights (CFLs), which last four to 10 times longer than incandescent bulbs and are four times more energy efficient. If you can not afford a complete changeover, replace the incandescent bulbs with CFLs in the lights that you use the most.

Choose outdoor lights with photocell units or motion sensors (or both) that turn the light on only when someone is present. Also consider CFLs for exterior lights (remember to include a cold-weather ballast).

## Appliances

Refrigerators, clothes washers and clothes dryers are the common home appliances that use the most energy (Figure 4). When you need new appliances, look for the ENERGY STAR® label. Refer to the appliance’s Energy Guide label for information on annual energy consumption and operating cost. Consider unplugging appliances that are not used regularly—many continue to use energy even when not actively used. Also, unplug electrical converters when not in use—they too continue to use energy. See “Resources” at the end of this chapter for ENERGY STAR® information.

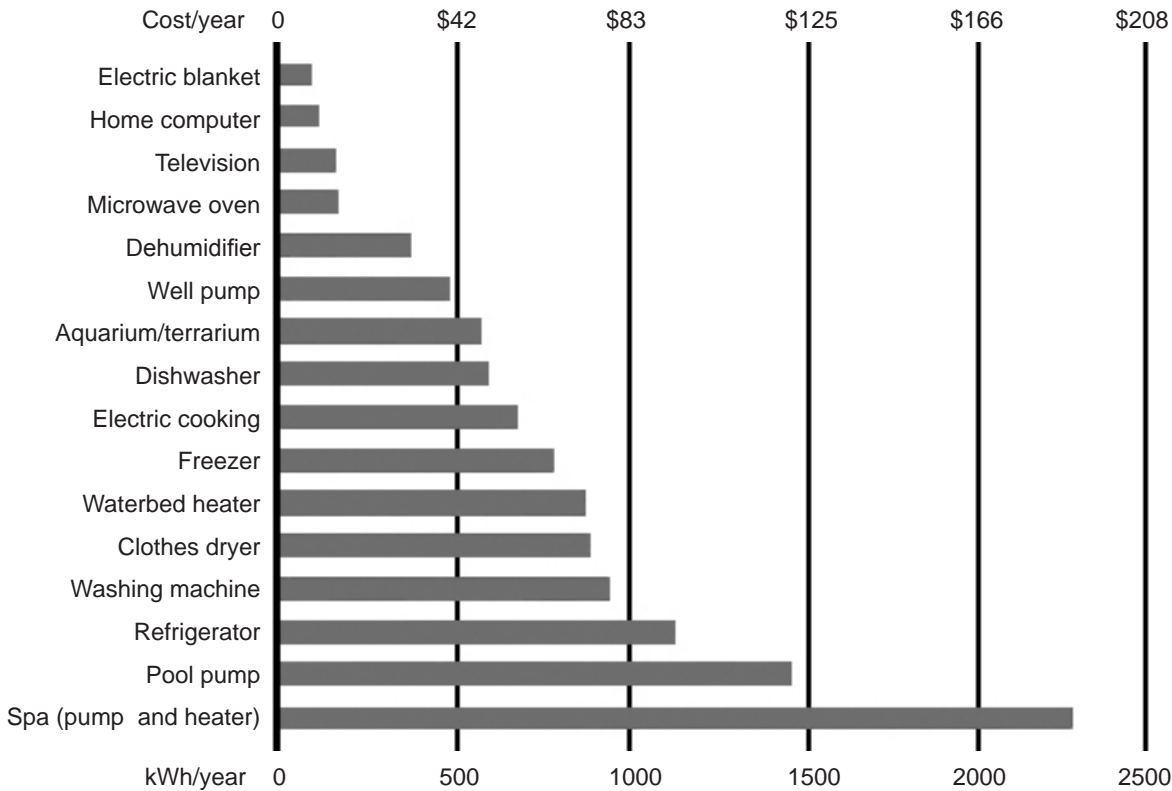

Figure 4: This chart shows how much energy a typical appliance uses per year and its corresponding cost based on national averages. *Energy Efficiency and Renewable Energy Information Center.*

## ✓ Assessment 1c - Increasing Efficiency of Domestic Water Heaters, Lighting and Home Appliances

In the assessment on the opposite page, indicate your potential energy-loss level in the right-hand column. Refer to the sections above if you need more information to complete the assessment.

### Responding to your energy-loss potential

Your goal is to reduce the amount of energy that is wasted. Turn to the Action Checklist at the end of the chapter to record the high and medium loss potentials you identified in the assessment. Use the recommendations in Part 1c to help you identify ways to increase energy efficiency.





	<b>Low energy loss</b>	<b>Medium energy loss</b>	<b>High energy loss</b>	<b>Your loss potential</b>
<b>Water temperature setting</b>	Water heater thermostat is set at 120 degrees F. Dishwasher has temperature booster turned on.	Water heater thermostat is set at 130 degrees F. Dishwasher has temperature booster turned on.	Water heater thermostat is set at 140°F or higher.	
<b>Insulation</b>	A new, highly insulated water heater or water heater blanket is installed.	No heater blanket, but water heater is inside heated house (vs. garage).	An older water heater with no added blanket is in use.	
<b>Hot water conservation</b>	Low-flow shower heads are installed, and there are no leaking faucets. Clothes are washed in cold water where possible. A conscious effort is made to conserve hot water.	There are no leaking faucets. Clothing is sometimes washed in cold water. Some effort is made to minimize hot water use.	There are leaking hot water faucets, and no low-flow fixtures are installed. Clothes are rarely washed in cold water.	
<b>Pipe insulation</b>	All accessible hot water pipes are insulated.	Some accessible hot water pipes are insulated.	There is no pipe insulation.	
<b>Energy-efficient bulbs</b>	Energy-efficient lights (CFLs) are used in all instances in the home.	Energy-efficient lights (CFLs) are used in lights with greatest usage.	Energy-efficient lights are not used at all.	
<b>Energy conservation</b>	Turn off all lights, televisions and power to other appliances when not in use.	Indoor and outdoor lighting is on timers and used only for security reasons.	Lights, television, stereos and other appliances are left on regularly.	
<b>Energy conservation</b>	ENERGY STAR® label appliances chosen when new appliances purchased.		No attention paid to choosing energy-efficient appliances.	

**A boxed risk level** indicates level required for Residential Environmental Assurance Program certification.

## Part 2 – Landscaping for Energy Conservation

Landscaping can help conserve energy as well as beautify your property. During the summer, properly placed trees and shrubs can help reduce cooling costs. In the winter, well-placed landscaping can reduce home heat loss by blocking cold winter winds. Additional benefits can be realized by selecting plants that are relatively pest-free and by designing a landscape that requires minimal water and fuel to keep it attractive.

The four main goals of energy conservation landscaping in Michigan are to:

- ◆ Maximize the amount of heat obtained from the sun during winter.
- ◆ Maximize shade during the summer.
- ◆ Protect buildings from winter winds.
- ◆ Channel summer breezes toward the home.

## Is landscaping for energy conservation worth the effort?

A well-designed landscape that includes well-placed trees can save 25 percent of a household's energy consumption for heating and cooling. Computer models developed by the U.S. Department of Energy predict that three properly placed trees will save an average household between \$100 and \$250 in annual energy costs. Consider that a young, 8-foot shade tree may cost about as much as an awning for a large window. As the tree grows, it will shade far more than a single window and will provide hundreds of dollars of savings during its useful life. Deciduous trees provide summer shade and then lose their leaves in the autumn. This allows the sun to shine on the house and provide winter warmth. The combination of shade and evapotranspiration (the process a plant uses to release water vapor for cooling) can reduce air temperature as much as 9 degrees Fahrenheit. Well-placed shade trees can result in considerable savings in energy for air conditioning. Compared with an unshaded home, a shaded home may have from 15 to 50 percent reduced energy cost for cooling. The figure will be higher for residents in mobile homes.

In winter, the ability of plants to block the wind will reduce air infiltration into homes. Such air leaks can account for as much as a quarter of the heat loss in the average home. Blocking winter winds can save energy used for home heating by 10 to 40 percent, depending on the study and the degree to which plants were used to block the wind.

Additional benefits from a well-designed landscape include dampening the sound from nearby roads or other sources of noise. Plants also remove particulate matter from the air and help control soil erosion, both of which help reduce pollution.

Develop a plan for the landscape around your home. Include all the existing features and plants and note the location of windows. Make sure the locations of underground utilities have been included. Then use arrows to show sun angles and the direction of prevailing winds for summer and winter. This will help determine which areas need summer shade and where windbreaks should be planted. Also, note the location or source of noise that could be blocked or reduced by landscape plantings. A landscape is an extension of the indoor space. Note frequent use areas such as play areas for children, storage areas, areas dedicated to pets and other uses. Make sure that landscaping installed for energy conservation does not block views that are important to the family. Give yourself a year to complete your landscape plan. This provides the opportunity to see how wind and sun affect your home in all four seasons. Make notes on the plan about the weather characteristics you would most like to modify. This will help set priorities when determining exactly which energy conservation choices you will incorporate into your landscape. A landscape that helps conserve energy can still be a source of enjoyment and beauty.



## ✓ Action Checklist

Go back over the assessments and record all high and medium risks and energy-loss potentials. Next, list the improvements you plan to make. You can use recommendations from this chapter or from other sources to help you pick actions you are likely to take. Write down a date to keep you on schedule. You don't have to do everything at once, but try to eliminate the most serious problems as soon as you can. Often it helps to tackle the inexpensive actions first.

Write all high and medium energy-loss potentials here.	What can you do to reduce the energy-loss potential?	Target date for action:
Example: Water heater is not insulated.	Buy a ready-made insulation blanket at the hardware store.	One week from today: March 8

## Resources

### American Council for an Energy Efficient Economy

The American Council for an Energy Efficient Economy provides information on energy-efficient appliances. Visit [www.aceee.org/consumer](http://www.aceee.org/consumer) or call 202-429-8873.

### Basic home energy audit

[www.cityofames.org/ElectricWeb/SelfAudit/Default.htm](http://www.cityofames.org/ElectricWeb/SelfAudit/Default.htm) or call 515-239-5177.

### Energy demonstration centers in Michigan

[www.warmtraining.org/medc](http://www.warmtraining.org/medc)

### Energy Efficiency and Renewable Energy Information Center

1-877-337-3463 or [www.eere.energy.gov](http://www.eere.energy.gov)

On the website, go to “Quick Links for Consumers,” then choose “Your Home.” This site provides information on appliances, lighting, space heating and cooling, water heating, energy audit and much more.

## [ENERGY STAR® information](#)

[www.energystar.gov](http://www.energystar.gov)

## [Energy Smarts Checklist for Home Energy Efficiency](#)

[http://extension.usu.edu/files/publications/factsheet/fact\\_sheet\\_3.pdf](http://extension.usu.edu/files/publications/factsheet/fact_sheet_3.pdf)

## [Michigan home energy services and resources](#)

[www.urbanoptions.com](http://www.urbanoptions.com)

## [Michigan residential energy efficiency information](#)

[www.michigan.gov/energyoffice](http://www.michigan.gov/energyoffice)

Select “Residential.”

## [Michigan State University Extension bulletins](#)

Available from your local MSU Extension office, or some are printable from the web: [www.emdc.msue.msu.edu](http://www.emdc.msue.msu.edu)

See the following bulletins under subject “Home Maintenance and Improvement”:

- E2091 Exterior Structural Items
- E2092 Interior Structural Items and Outside Areas
- E2788 Checklist for Building a New Home
- E2789 Checklist for Existing Homes
- E2790 Energy Conservation Tips
- E2791 Energy Efficient Windows
- E2792 Energy Efficient Applications
- E2793 Controlling Hot Water Heating Costs
- E2794 Weatherstripping
- E2795 Selection of Weatherproofing Materials
- E2796 Geothermal Heating
- E2797 Choosing a Furnace
- E2798 Insulation
- E2799 Landscaping Tips
- E2800 Landscaping for Winter Winds
- E2801 Landscaping for Summer Cooling
- E2802 Energy Efficiency in Lighting

## [More than 100 Ways to Save on Your Energy Bill](#)

[www.consumersenergy.com/apps/pdf/more-100-ways-save-on-bill12-06.pdf](http://www.consumersenergy.com/apps/pdf/more-100-ways-save-on-bill12-06.pdf)

This Home\*A\*Syst chapter covers a variety of topics to help homeowners examine and address their most important energy concerns. See the complete list of chapters in the table of contents at the beginning of this handbook. For more information on topics covered in Home\*A\*Syst, contact your local MSU Extension office.

This chapter was written by Lori S. Marsh, Department of Biological Systems Engineering, Virginia Polytechnic Institute and State University, and updated and adapted for use in Michigan by Roberta Dow and Suzanne Ebright, Michigan Groundwater Stewardship Program, 2008.





This chapter examines potential risks to the environment and your health from stormwater runoff. Two areas are covered:

### 1. Reducing pollutants in runoff

- ◆ Pesticides and fertilizers
- ◆ Pet and other animal wastes
- ◆ Automotive wastes
- ◆ Winter deicers
- ◆ Grass clippings and yard waste

### 2. Controlling runoff

- ◆ Preventing soil erosion
- ◆ Minimizing paved surfaces
- ◆ Basement flood protection
- ◆ Roof drainage
- ◆ Landscaping

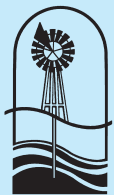

Michigan  
Groundwater  
Stewardship  
Program

**MICHIGAN STATE**  
**UNIVERSITY**  
**EXTENSION**

## Chapter 7. Managing Stormwater around Your Home

### What is stormwater and why should you be concerned?

**Stormwater** is water from rain or melting snow that does not soak into the ground. It flows down slopes and roads, along ditches or from rooftops, over paved areas, across bare soil, and through sloped lawns and fields. As it flows, this runoff collects and transports soil, pet waste, salt, pesticides, fertilizer, oil and grease, yard waste, litter and other potential pollutants. You don't need a heavy rainstorm to send pollutants rushing toward streams, wetlands and lakes—your hose can supply enough water. Even if your house is not on the waterfront, storm drains or storm sewers carry runoff from your neighborhood to the nearest stream, wetland or body of water. Contrary to popular belief, most storm sewers do not carry stormwater to sewage plants for treatment. Often they flow right into the water you enjoy for swimming and fishing.

Polluted stormwater lowers the quality of Michigan's lakes, rivers and wetlands. Soil clouds water and degrades habitat for fish and water plants. Nutrients such as phosphorus and nitrogen from fertilizers and animal wastes promote the growth of algae, which crowd out other aquatic life. Toxic chemicals such as antifreeze and oil from leaking cars, carelessly applied pesticides, and zinc from galvanized metal gutters and downspouts threaten the health of fish and other aquatic life. Bacteria and parasites from pet, waterfowl and other animal waste can affect nearby inland lakes and streams. As many people have discovered, stormwater can be a problem closer to home, flowing into basements, where it can be difficult and hazardous to clean up. Stormwater can also flow down an abandoned well or poorly sealed well casing (pipe) and contaminate drinking water.

In Michigan and across the country, public officials are turning their pollution control efforts from wastewater discharges to stormwater management in urban and rural areas. The problem cannot be treated in the same way as water pollution from discharge pipes. This pollution does not come from a few sources. It is carried by stormwater from every street, parking lot, yard and garden. The problem can be solved only by an individualized and collaborative effort from everyone.

There are two ways to reduce the risks posed by stormwater:

- ◆ Keep pollutants out of stormwater.
- ◆ Reduce the amount of stormwater runoff.

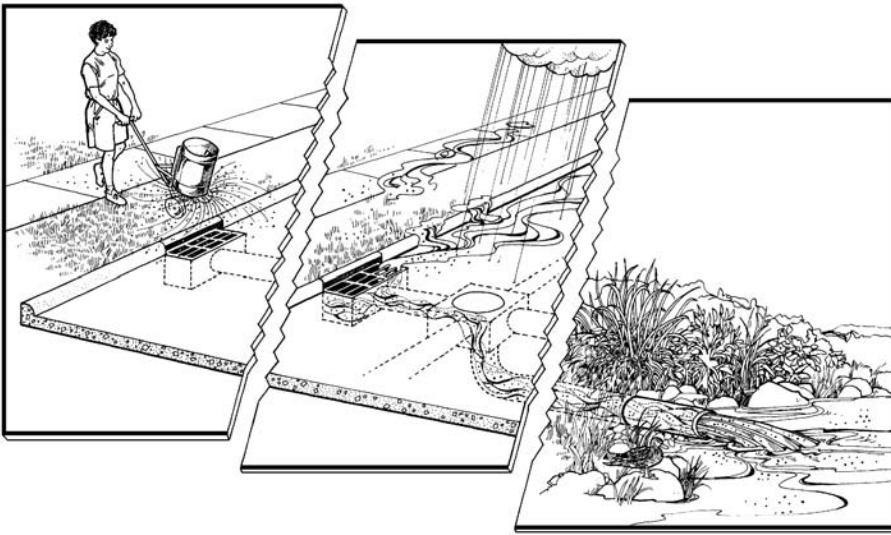

Figure 1: Chemicals used near storm drains (storm sewers) can be carried by rain runoff into the drain and on into the nearby lake or stream.

### Where does stormwater go?

The next time you are home during a storm, head outdoors with your boots and umbrella and watch where the rainwater goes. On the sketch of your property in Chapter 1, “Site Assessment,” draw arrows showing the direction that stormwater flows off driveways, rooftops, sidewalks and yards. Does water soak into the ground quickly, or does it puddle in places and flow off lawns and gardens? Your soil type affects water infiltration (soaking into the ground). As you might expect, water infiltrates sandy soil quickly but has a hard time seeping into fine-grained silt or clay soils. Infiltration is preferred, but infiltrating storm water still needs to be kept as pollutant-free as possible. During your walk, note how far it is to the nearest storm sewer, ditch, wetland, stream or body of open water.

## Part 1 – Reducing Pollutants in Runoff

Stormwater is unavoidable, but its effects can be reduced by keeping harmful chemicals and materials out of the runoff (Figure 1). This section reviews the major potential sources of contamination and offers ways to minimize them. At the end of Part 1, fill out the assessment to help identify stormwater risks on your property.

### Are household products stored out of the reach of stormwater?

Most households keep lawn and garden products such as weedkillers, insecticides and fertilizers in storage. If stormwater or floodwater reaches these products, it can transport them into surface water and your well. Pool chemicals, salt from water softeners and a wide variety of other chemicals and products also can cause trouble if they are washed away. Keeping such products in waterproof containers and storing them up high and out of the potential path of runoff or floods are important. You can avoid storage problems by buying what you need for a particular use and then using it according to the instructions on the label.

**Use and handling.** Safe storage is only the first step in preventing contaminated runoff. When you spill chemicals, act quickly to contain and clean up the spill. This is particularly important on paved surfaces. Granular



fertilizers and pesticides should be swept off of paved surfaces into the yard. Never wash or dump paint, fertilizers, pesticides or other chemicals into the storm drain. Using more pesticides and fertilizers than you need invites pollution problems. Timing of applications is also important. Avoid applying pesticides and chemicals if heavy rainfall is expected within 24 hours. See Chapter 9, "Caring for Your Yard and Garden," for more information on using these yard and garden products.

### **Are any motor wastes being carried away by stormwater?**

Oil stains on your driveway and outdoor spills of antifreeze, brake fluid and other automotive fluids are easily carried away by a rainstorm. If the runoff from your driveway has an oily sheen, this is a sure sign of your need to be more careful. Pans, carpet scraps and matting can catch drips. Routine maintenance prevents your car from leaking and identifies potential leaks. Be careful if you change your own oil to avoid spills and collect waste oil for recycling. Oily car parts and fluid containers should be stored where rain and runoff cannot reach them. Never dump used oil, antifreeze or gasoline down a storm drain, in a ditch or on the ground. These wastes will end up in a nearby lake or stream, or they may pollute your drinking water.

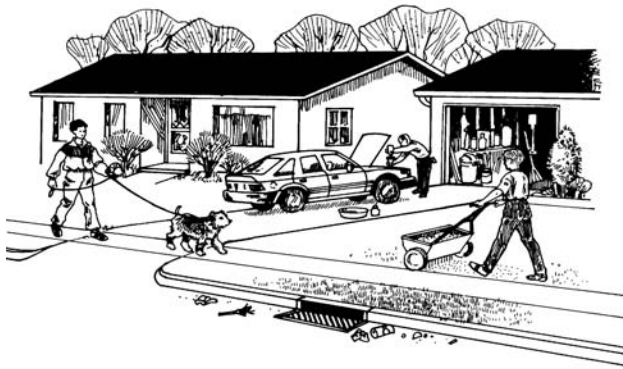

Washing your car in the driveway creates runoff problems without the assistance of a rainstorm. Your hose provides the water. The dirty, soapy runoff drains directly into sewers, picking up oil and other pollutants as it goes. Try washing your car on the lawn. Or better yet, take it to a commercial car wash or spray booth that sends its dirty water to a wastewater treatment plant.

Boats and campers with wastewater collection systems should be drained at designated wastewater disposal sites, not on the ground or into storm sewers, where they can contaminate surface water.

### **Do you use road salt or other deicing products?**

All road salt and deicers eventually wash off of paved surfaces and end up in the soil or water. From your driveway or sidewalk, salt can readily flow to storm drains and then into streams and lakes. Salt in high concentrations is harmful to wildlife and plant life. Use less to keep these chemicals out of natural systems. If you use too much, clean up the excess. Consider sand or gravel as less toxic alternatives. Chipping ice off pavement is another good choice.

### **How do you keep animal wastes from becoming a pollution problem?**

Droppings from dogs and cats and from commonly kept animals such as rabbits, goats and chickens can be troublesome in two ways. First, pet wastes contain nutrients that can promote the growth of algae if they enter streams and lakes. Second, animal droppings are sources of disease organisms. The risk of stormwater contamination increases if pet wastes are concentrated in animal pen areas or left on sidewalks, streets or driveways where runoff occurs. Droppings should be buried if local laws allow, flushed along with human wastes down the toilet or placed in the trash (depending on local rules).

## Are yard and garden plant wastes kept out of stormwater?

If left on sidewalks, driveways or roads, grass clippings and other yard wastes will wash away with the next storm. Although leaves and other plant debris accumulate naturally in streams and lakes, homeowners can contribute excess amounts of plant matter by letting their clippings and other plant debris go down the storm drain. This can lead to water that is overfertilized and unsuitable for recreation. This risk is especially high in urban areas because of the large areas of hard surfaces enabling more runoff.

Burning is not an environmentally friendly alternative. Hydrocarbons and nutrients released by burning leaves contribute to water and air pollution. Rain washes smoke particles out of the air, and runoff picks up dust and ashes left on pavement or in ditches.

Avoiding problems with plant waste is easy—sweep clippings back onto the grass, and compost leaves on your property to recycle nutrients for later use. Many communities have plant material pickups and provide wood chips and compost for gardening.

## ✓ Assessment 1 – Reducing Pollutants in Runoff

Use the following assessment to rate your stormwater pollution risks. For each question, write your risk level (low, medium or high) in the column labeled “Your risk.” Although some choices may not correspond exactly to your situation, choose the response that fits best. Refer back to Part 1 if you need more information to complete this assessment.

	<b>Low risk/ recommended</b>	<b>Medium risk/ potential hazard</b>	<b>High risk/ unsafe situation</b>	<b>Your risk</b>
<b>Storage of pesticides, fertilizers and other potentially harmful chemicals</b>	Stored in waterproof containers in garage, shed or basement above reach of stormwater.	Stored in waterproof containers but within reach of stormwater.	Stored in non-waterproof containers outdoors or within reach of stormwater.	
<b>Handling and use of pesticides, fertilizers and outdoor chemicals</b>	Spills or misapplications cleaned up properly and immediately, particularly on paved surfaces. Amounts applied according to label. Applications timed to avoid rain.	Applications applied when rainfall is imminent or predicted.	Spills or misapplications not cleaned up. Products used in amounts higher than label recommendations.	
<b>Vehicle washing</b>	Cars, trucks, campers, etc., taken to a commercial car wash or spray booth.	Cars, trucks or other vehicles washed on a lawn or gravel drive.	Cars, trucks or other vehicles washed on driveways, streets or other paved areas.	
<b>Motor wastes</b>	Oil drips and fluid spills cleaned up. Dirty car parts and other vehicle wastes kept out of stormwater runoff.	Drips not cleaned up. Car parts and other vehicle wastes piled on unpaved areas outside.	Used oil, antifreeze and other wastes dumped down the storm sewer, in a ditch or on the ground.	

**A boxed risk level** indicates level required for Residential Environmental Assurance Program certification.

*Continued on next page...*



...Assessment 1 continued

	<b>Low risk/ recommended</b>	<b>Medium risk/ potential hazard</b>	<b>High risk/ unsafe situation</b>	<b>Your risk</b>
<b>Pet and animal wastes</b>	Animal and pet wastes (droppings) are flushed or buried away from any garden, well, ditch or area where children play.	Animal wastes left to decompose on grass or soil. Wastes scattered over wide areas away from ditches, play areas, well or storm drain.	Animal wastes left on paved surfaces or concentrated in pen or yard areas or dumped down the storm drain or in a ditch.	
<b>Grass clippings, leaves, mulch and other yard waste</b>	Clippings, leaves and other yard wastes swept off paved surfaces and onto lawns away from water flow routes. Leaves and other yard wastes composted.	Leaves and other yard wastes piled on the lawn next to the street for collection. Leaves and other yard wastes burned outdoors away from paved areas or ditches.	Grass clippings, leaves and other yard debris left on driveways, streets and other paved areas where they will be carried off by stormwater. Leaves burned on paved areas or in ditches.	

**A boxed risk level** indicates level required for Residential Environmental Assurance Program certification.

### Responding to risks

Your goal is to lower your risks. Turn to the Action Checklist at the end of this chapter to record the medium and high risks you have identified. Use the recommendations in Part 1 to help you make plans to reduce your risks.

## Part 2 – Landscaping and Site Management to Control Runoff

Some stormwater risks can be controlled by changes to buildings, paved surfaces, landscaping and soil surfaces. This section reviews some easily addressed problems, as well as major landscape alterations you might want to consider.

### Are there areas of bare soil around your home?

You can find areas of bare soil in vegetable and flower gardens, in newly seeded lawns and around construction projects. Even on gentle slopes, water from rain and snow can remove large amounts of soil and deliver it to wetlands, rivers and lakes. Planting grass or other ground covers is the best way to stop erosion. Putting straw over newly seeded areas or chip mulch over gardens will slow erosion. Straw bales, diversion ditches and commercially available silt fences around construction sites can help slow runoff and trap sediment on site.

### Can you eliminate paved surfaces or install alternatives?

Concrete and asphalt roads, driveways and walkways prevent rainwater from soaking naturally into the ground. When you have the choice, consider alternatives such as gravel or wood chip walkways. Avoid paving areas such as patios. Where you need a more solid surface, consider using a porous pavement made from interlocking cement blocks, brick pavers or rubber mats with spaces that allow rainwater to seep into the ground. If you must pour concrete, keep the paved area as short and narrow as possible.

## Is your basement protected from stormwater seepage or flooding?

Stormwater in your basement can be a hazard in three ways: the water can carry chemical contaminants or disease organisms into your home; the water can pick up chemicals stored in your basement and carry them into the sewer or ground; and the water creates electrocution risks. Basement windows or doors are common entry points and should be sealed against leaks. It is best if window and door sills are at least a foot above ground level. If windows are at ground level or below, they can be protected with clear plastic covers available in building supply stores. Window wells that extend above ground level can help divert stormwater. Your yard should be sloped away from the house foundation to prevent water from pooling near the house and leaking into the basement.

## Does water from roofs flow onto pavement or grass?

Your house roof, like pavement, sheds water. If downspouts from roof gutters empty out on grassy or plant areas, the water will have a chance to soak naturally into the ground. Aim your roof downspouts away from foundations and paved surfaces. Keeping gutters clean helps move water to intended absorption areas. For roofs without gutters, you can plant grass, spread bark mulch, or use gravel under the drip line to prevent soil erosion and increase the ground's capacity to absorb water. Consider using cisterns or rain barrels to catch rainwater for watering lawns and gardens in dry weather.

## Can you change the layout of your landscape to reduce runoff?

An essential part of stormwater management is keeping water from leaving your property or at least slowing its flow as much as possible. Many home lawns have slopes that encourage water to run off onto neighboring property or streets. Instead, you could provide a **rain garden**, a low maintenance perennial garden that is designed to catch stormwater and allow it to soak into the ground. It is planted in a wet spot, a place where water naturally flows, or a place where water can be diverted. A rain garden, when installed correctly, should not have standing water for more than a day; it is not a pond. Building a successful rain garden involves a good location, some soil work and the right plants. See "Resources" at the end of this chapter.



If your yard is hilly, you can terrace slopes to slow the flow of runoff and make mowing and gardening easier. If you have a large lot, consider naturalizing areas with native plants. If your property adjoins a lake or stream, one of the best ways to slow and filter runoff is to have a buffer strip of thick natural vegetation along the waterfront. A good source for ideas is your local MSU Extension or conservation district office.



## ✓ Assessment 2 – Managing Runoff around Your Home

In the assessment, write your risk level (low, medium or high) in the column labeled “Your risk.” Select the answer that best matches your situation. Refer to the information in Part 2 above if you need more information to complete this assessment.

	<b>Low risk/ recommended</b>	<b>Medium risk/ potential hazard</b>	<b>High risk/ unsafe situation</b>	<b>Your risk</b>
<b>Bare soil in lawns and gardens</b>	Bare lawn spots promptly seeded and topped with a straw layer. Bare garden soil covered with mulch.	Grass or other ground cover is spotty, particularly on slopes.	Spots in lawn or garden left without mulch or vegetation for long periods.	
<b>Bare soil during construction or remodeling</b>	Bare soil seeded and mulched as soon as possible (before construction is complete). Sediment barriers used until grass covers soil.	Soil left bare until construction is completed. Sediment barriers installed and maintained to detain muddy runoff until grass covers soil.	Soil left bare and no sediment barriers used.	
<b>Paved surfaces</b>	Paved surfaces minimized. Alternatives such as wood chips or paving blocks used for walkways and other areas.	Some small areas paved for patios or basketball.	Paved surfaces used extensively.	
<b>Basement protection</b>	Stormwater diverted from basement windows by window well covers and other devices. Yard is sloped away from foundation, and downspouts direct roof drainage away from house.	No special water diversion methods installed, but stormwater has never entered basement.	Water diversion methods attempted. Stormwater runoff has entered basement or flows near the foundation.	
<b>Roof drainage</b>	Downspouts and drip lines direct roof drainage onto lawn or garden where water soaks into the ground.	Some downspouts and drip lines discharge water onto paved surfaces or grassy areas where water runs off.	Most or all drip lines or downspouts flow onto paved surfaces. Or downspouts connect directly to storm drains.	
<b>Landscaping and buffer strips</b>	Yard landscaped to slow stormwater flow and provide areas where water soaks into the ground. Unmowed vegetation buffer strips present along streams and lakeshores.	No areas landscaped to encourage water to soak in, but yard is relatively flat and little runoff occurs. Mowed grass or spotty vegetation adjacent to stream or lake.	No landscaping to slow the flow of stormwater, especially on hilly, erodible properties. Stream banks or lakeshores eroding.	
<b>A boxed risk level</b> indicates level required for Residential Environmental Assurance Program certification.				

### Responding to your risks

As before, your goal is to lower your risks. On the Action Checklist below, record medium and high risks you have identified. Use the recommendations in Part 2 to help reduce your risks.

## ✓ Action Checklist

Go back over the assessment charts and look for the high and medium risks you identified. Record them below. For each medium and high risk listed, write down the improvements you plan to make. Use recommendations from this chapter and other resources to decide on an action you are likely to complete. A target date will help keep you on schedule. You don't have to do everything at once, but try to eliminate the most serious risks as soon as you can. Often it helps to tackle the inexpensive actions first.

Write all high and medium risks here.	What can you do to reduce the risk?	Target date for action:
Fertilizer and pesticides stored on soil floor in storage shed.	Put fertilizer bags in plastic covered storage bins, put on shelf out of hazard of flooding.	One week from today: May 15

## Resources

### Landscape management

Contact your local Michigan State University Extension office for information on landscape management. Contact the Department of Environmental Quality Environmental Response Division for information on non-point source pollution. Contact the Natural Resources Conservation Service or local drain commissioner for information on stormwater management techniques.

### Websites and publications

**“Lakescaping for Wildlife and Water Quality.”** MSU Extension Bulletin WQ57

**“Landscaping for Water Quality.”** 2004. Jane Secord (ed.), Center for Environmental Study, Grand Rapids, Mich. Available at [www.deq.state.mi.us/documents/deq-wb-nps-Landscaping-for-Water-Quality.pdf](http://www.deq.state.mi.us/documents/deq-wb-nps-Landscaping-for-Water-Quality.pdf)

Stormwater-related publications available from the West Michigan Environmental Action Council, 1007 Lake Drive SE, Grand Rapids, MI 49506; 616-451-3051; [www.wmeac.org](http://www.wmeac.org)

[www.RainGardens.org](http://www.RainGardens.org)

This chapter was written by Carl DuPoldt, environmental engineer, Natural Resources Conservation Service, Somerset, N.J., and Carolyn Johnson, water quality education specialist, University of Wisconsin Extension, Milwaukee, and adapted for Michigan by Tom Cary, West Michigan Environmental Action Council, and Dean Solomon, Roberta Dow and Jim Bardenhagen, Michigan State University Extension. Updated in 2008.





This chapter helps you understand the importance of water and the water cycle. It also examines the need to conserve water. Two areas are covered:

### 1. Reducing water usage indoors

- ◆ Plumbing leaks
- ◆ Insulated water pipes
- ◆ Bathroom considerations
- ◆ Water turn-off valves
- ◆ Water-conserving appliances
- ◆ Water conservation practices

### 2. Reducing water usage in yard and garden

- ◆ Landscaping choices
- ◆ Lawn care practices
- ◆ Irrigation techniques
- ◆ Soil improvements and cultural practices
- ◆ Washing vehicles



Michigan  
Groundwater  
Stewardship  
Program

## Chapter 8. Conserving Water around Your Home

“When the well’s dry, we know the worth of water.” – Benjamin Franklin

### Why should you be concerned?

Water is essential for life. Humans can survive for about a month without food but only about seven days without water. Water, however, is a limited resource. We have the same amount of water on earth today as thousands of years ago. It moves around in the water cycle (Figure 1), so areas that may have been wet may now be dry or vice versa. There is no new water—the water is reused and recycled. For example, an apple may contain rain water from yesterday, which was water that fell hundreds of miles away a year ago and was also drunk by a dinosaur millions of years ago.

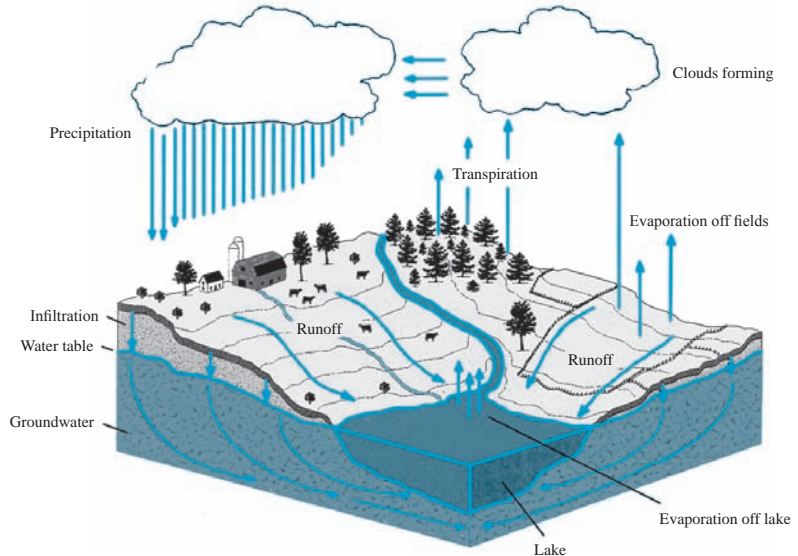

Figure 1: The water cycle.

“Understanding Groundwater.”

*Institute of Water Research/ Center for Remote Sensing, MSU.*

### The water cycle

Water moves from land to groundwater to surface water to air (Figure 1).

**Precipitation**—rain, snow, sleet and hail—brings water to the earth. This is taken up by the ground through **infiltration**. Plants may take up the moisture and release it back to the air through the process of **transpiration**. Some of the precipitation runs off the surface of the ground and into surface waters such as lakes and streams. These bodies of water may lose water to groundwater if the water table is low or gain water from groundwater if the water table is high. These bodies may also lose moisture through **evaporation**, which occurs even in cold weather if the water is not ice-covered. In Michigan, the water moves to the Great Lakes and then on to the Atlantic Ocean.

## Do we have enough water?

Most of the water on earth (about 97 percent) is salt water, which is costly to convert to usable water for consumption by plants, animals and humans (Figure 2). Fresh water makes up only about 3 percent of the earth’s water, and most (two-thirds) of this is frozen polar ice caps and glaciers. Fresh groundwater and surface water make up 31 percent. With global warming and melting of the ice, we are losing more fresh water to the saltwater oceans.

Demand for water is increasing globally. Drought, overpopulation, increased usage and pollution are all contributing to the water crisis. Global consumption is doubling every 20 years. This is more than twice the rate of human population growth. Pollution and overextraction further limit water resources in many areas of the world. Scarcity of water may lead to water conflicts in the future. Over a billion people in the world lack access to drinkable water. The world’s 6 billion people are already using about 54 percent of all the accessible fresh water contained in rivers, lakes and underground aquifers. According to data collected from NASA and the World Health Organization, 4 billion people will face water shortages by 2050.

Michigan, the Water Wonderland, is blessed with the surrounding Great Lakes (20 percent of the world’s fresh surface water). However, this does not mean that overuse or mismanagement of our water resources cannot affect our lakes, streams, wetlands, wildlife, plant life, agriculture, industry or economy, or our future water use. As populations grow, controversies grow over who controls the water. Our precious water resources need to be protected and conserved for current and future use.

Even in Michigan, water usage is a significant expense. There are pumping, heating, water treatment and wastewater treatment costs. If you have a septic system, water conservation can extend the time between tank pumpings (see Chapter 11, “Managing Household Wastewater”). It can also extend the life of your drainfield, saving replacement costs of \$3,000 or more. If you have municipal water and sewage, the more you use, the more you pay. Water conservation can mean homeowner as well as community savings.

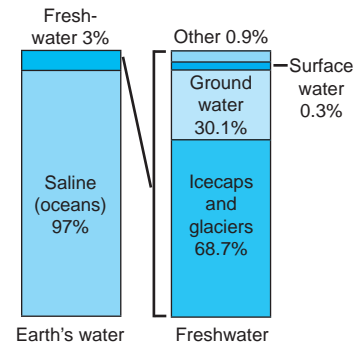

Figure 2: Distribution of Earth’s water.  
U.S. Geological Survey.

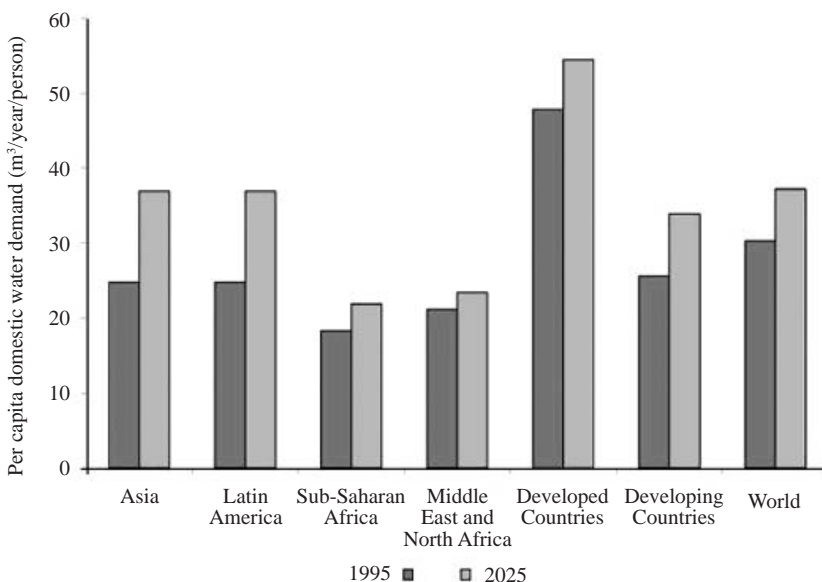

Figure 3: Per capita household water consumption for the world and by region for 1995 and a business-as-usual projection for 2025. *Global Water Outlook to 2025: Averting an Impending Crisis.*

## How can I conserve water?

*“Water is not like oil. There is no substitute.” – Dr. Mark Rosegrant, International Food Policy Research Institute.*

Drought, overpopulation and pollution are all contributing to the water crisis, but so are water waste and overuse. The domestic water consumption per person for the world and by regions of the world is shown in Figure 3 with a projection for 2025 if there is no change in behavior and with current population and other projections.

## Part 1 - Reducing Water Usage Indoors

Water use estimates vary, but the U.S. Geological Survey states that the average American uses 80 to 100 gallons of water in the home daily. That’s a lot of water! Reductions can be made through repairing leaks, using new technologies and changing water use behaviors. See what you can do to make a difference.

### Do you have plumbing leaks?

Plumbing can be a source of leaks and water loss. If you are on a public water supply, check the water meter when no water is being used or is going to be used in the house. After two hours, check it again. If there is any usage shown, that indicates a leak somewhere. If you have a private well and you can hear the pump come on regularly when you’re not using water, you have a leak. The leak may be in the toilet, faucets, plumbing or appliances. To check for a toilet leak, put some food coloring in the tank. If color appears in the bowl without flushing, you have a leak that needs repair. It may require getting a new flapper or adjusting the float rod on an old-style conventional toilet or getting a new valve ring, gasket or flushvalve for newer toilets. Faucet leaks generally can be repaired simply by replacing the washer.

### Bathroom considerations

Three-fourths of the water used in the home is used in the bathroom; the toilet accounts for over a fourth of this. Conventional (old-style) toilets using 5.5 gallons per flush use an estimated 13,000 gallons per year to get rid of 165 gallons of body waste. Installation of low-flow or ultra low-flow toilets can save 1.5 gallons to 4.7 gallons per flush (Figure 4). The new ultra low-flow toilets use a pressurized tank to provide high pressure flow of a smaller amount of water, giving water efficiency with high user satisfaction.

If a new toilet is not practical, you can use a plastic bottle filled with water or pebbles or a commercial toilet dam placed in the toilet tank to save water. Leave 3 gallons in your tank for effective flushing.

Stopping use of the toilet as a disposal for things such as cigarettes, bugs and small bits of paper also halts unnecessary flushes and water waste.

Preparing a bath may be another source of wasted water if the water is run to get the proper temperature prior to plugging the tub. It is more economical and wastes less water to plug the tub drain first and begin filling the tub, adjusting the water temperature as it is filled.

Installing low-flow plumbing fixtures such as faucet aerators and low-flow shower heads can lower your hot water heating costs as well as your water usage. Aerators can cut flow by 50 percent. They mix air with water, which helps prevent splashing and cuts water use. If your shower can fill a 1-gallon bucket in less than 20 seconds, then you do not have a water-efficient showerhead. Older conservation models simply blocked some of the water flow. Today's low-flow heads move the water through special openings that control droplet size, focus the stream and, in some heads, increase the blast by adding air, creating turbulence or pulsing. Consumer product evaluations have shown consumer satisfaction with many of the heads that are now available. It's best to check evaluations before you purchase one. Also, installing anti-scald valves or lowering your water heater temperature may be recommended to prevent scalding when the toilet is flushed if you have less than 3/4-inch diameter piping.

### Are your hot water pipes insulated?

Hot water takes longer to reach you in cold pipes because the water cools as it passes through. Insulating pipes with split foam pipe insulation (see Chapter 6, "Energy Savings for Your Home") allows faster delivery of hot water, saving water, energy and money.

Equipment	Gallons per use	Savings	Equipment/activity	Gallons per use	Savings
<b>Toilet</b>			<b>Washing machine</b>		
Conventional	5-5.5		Conventional top load	37	
Low-flow	3.5	36%	Wash recycle	26	30%
Ultra low-flow	.8-1.6	up to 85%	Front load	21	43%
			X-axis	17.5	53%
<b>Showerheads (per min.)</b>			<b>Shaving</b>		
Conventional	5		Open tap	5-10	
Low-flow	2.5	50%	1 full basin	1	80-90%
<b>Bath</b>			<b>Dishwashing</b>		
Full tub	30-45		By hand - open tap	30	
1/4 to 1/3 full	9-12	60-80%	Dishwasher - full load	10-15	50-66 % over open tap
<b>Faucets (per min.)</b>			By hand - full basin, wash & rinse	5	83% over open tap
Conventional	3				
Low-flow	2.5	16%			

Figure 4: Water use by conventional and efficient household equipment or behaviors.

### Do you and members of your family know where the water turn-off valves are?

There is a main water turn-off valve that stops water from coming into your piping system, whether you have a drinking water well or city water. Knowing the location of this may protect your home from flooding due to a burst pipe or damaged appliance. Also, under each sink is a hot and cold water turn-off valve that controls water to the faucets. Toilets, clothes washers and dishwashers also have turnoff valves.

### Do you have water-conserving appliances?

Today, low-water-usage appliances are readily available. Efficient dishwashers and washing machines can save .3 to 5 gallons per load. Front-loading washing machines use less water than top-loading types. A few washing machines have suds-saver systems that put the wash water into a tub or pump it into a built-in tank. The wash water is stored and is pumped back for reuse for another wash load. The rinse cycle continues to be a single use.





New water softeners also use less water than older models. Water softeners take the hardness, calcium or magnesium, out of water by exchanging it on a column with sodium (in most softeners) or potassium (which is better for the environment). Water plus sodium chloride or potassium chloride is used to refresh the column so it can soften more water. Old softeners do this on a timer and thus may flush too often if the timer is set for short cycles. New efficient softeners have a sensor and refresh when the column needs it.

**Do members of your family practice water conservation when they use water?**

Teach members of the family to turn off the water in between various operations such as wetting the toothbrush and brushing, cleaning the shaver and shaving, or wetting the hair and soaping the hair. It saves water. Taking shorter showers and turning the water off between soaping up and rinsing is a good practice. A 4-minute shower uses 20 to 40 gallons of water, depending on your shower head.

Hand washing of dishes using one side of the sink with soapy wash water and the other side with rinse water is more conservative than rinsing them with continuous running water (see Figure 4). Using water from a chilled refrigerator dispenser or from a pitcher of water in the refrigerator saves running the faucet until the water is cold for a drink. Running fully loaded dishwashers and clothes washers provides optimum water conservation. For partial loads, conserve water by adjusting the water levels to match the load size.

Using a garbage disposal requires running water. If you have a septic system, this also means that you have to pump it more often because of the buildup of solids (see Chapter 11). If you are on a city waste water system, it increases the city’s costs. Instead, consider composting your vegetable waste. This saves water and gives the added benefit of compost for your garden (see Chapter 9, “Caring for the Yard and Garden”).

**✓ Assessment 1 – Risks Related to Indoor Water Usage**

Use the following assessment to rate your water conservation efforts. For each question, put your risk level (low, medium or high) in the column labeled “Your risk.” Choose the response that best fits your situation. Refer to the information in this chapter if you need help to complete this assessment.

	<b>Low risk/ recommended</b>	<b>Medium risk/ potential risk</b>	<b>High risk/ unsafe situation</b>	<b>Your risk</b>
<b>Plumbing</b>	Water meter or well pump indicates no change over 2-hour period when water not used, therefore no leaks. Or, leaks have been corrected.		Faucets drip and/or toilet leaks water from tank into bowl, and/or plumbing joints leak.	
<b>Toilet</b>	Low-flow or ultra low-flow type.	Toilet tank contains plastic bottle filled with pebbles or water, or toilet dam.	Non-conserving toilet present (pre-1980s) and not modified to decrease water usage.	
<p><b>A boxed risk level</b> indicates level required for Residential Environmental Assurance Program certification.</p> <p style="text-align: right;"><i>Continued on next page...</i></p>				

...Assessment 1 continued

	<b>Low risk/ recommended</b>	<b>Medium risk/ potential risk</b>	<b>High risk/ unsafe situation</b>	<b>Your risk</b>
<b>Toilet usage</b>	Toilet used only for human waste, not for small bits of trash, etc. Know how to adjust toilet flapper so it doesn't stay open.	Toilet rarely used for small bits of non-human waste.	Toilet regularly used as ashtray or wastebasket and flushed each time small bits of trash added. When flapper is stuck open, have no idea how to fix it.	
<b>Shower</b>	Water-saving shower heads installed. Shower turned off when soaping up. Short showers the rule.	Water-saving shower head not present, but short showers taken.	No effort to save water during showering. Showers longer than 5 minutes.	
<b>Faucets</b>	Low-flow faucets present. Faucets tightly turned off after each use. Water turned off after wetting toothbrush, soaping hands, shaving or shampooing. Faucets repaired as needed.	Some faucets with aerators or low-flow type present. Faucets generally turned off. Repaired as needed.	No low-flow faucets or faucets with aerators present. Faucets often left running. Faucet left running while brushing teeth, soaping hands, shaving or shampooing in shower. Dripping faucets present.	
<b>Main / sub water valve locations</b>	Family knows how to turn off main water valves and valves under sinks, toilets and appliances.	Valves located but inoperable or inaccessible.	Family has no idea how to turn off water if major leak occurs.	
<b>Wash machines</b>	Automatic dishwasher and clothes washer run fully loaded. When purchasing new equipment, machines that conserve water selected.	Partial loads run, but water levels adjusted accordingly.	Partial loads run without adjusting water levels. Water conservation never considered when purchasing new equipment.	
<b>Hand dishwashing or produce washing</b>	Dishes washed in soapy water on one side of the sink and rinsed in water held in the other side. Vegetables washed in sink or pan.	Water run to rinse dishes or wash vegetables but turned off in between.	Water run continuously while washing and rinsing.	
<b>Food waste</b>	Appropriate food scraps composted.		Garbage disposal used regularly. No composting done.	
<b>Hot water pipes</b>	Pipes insulated with split foam pipe insulation, allowing faster delivery of hot water.		Pipes uninsulated.	

**A boxed risk level** indicates level required for Residential Environmental Assurance Program certification.

## Responding to risks

As always, your goal is to lower your risks. Use the Action Checklist at the end of this chapter to record the medium and high risks you have identified. Use recommendations in this chapter to help you make plans to reduce your risks.

## Part 2 - Reducing Water Usage in the Yard and Garden

### Do you consider your landscaping?

Landscaping to minimize irrigation needs will save not only water but time and money. It's important to choose the right plants for your site, usage and region. Consider drought-tolerant and native plants—they have adapted to need less water or to your area's growing conditions. When planning a lawn, consider the amount needed and whether other more drought-tolerant plantings might be used to decrease the amount of thirsty turf.

### What are your lawn care and irrigation practices?

Lawn care is often the biggest user of water at the home. See Chapter 9 for recommended lawn watering and water-saving ideas. There are ways you can conserve water while irrigating. Using a water meter will help you put down the amount you intend. Turning the water on and off rather than using an automatic system means you'll not be watering when it's raining. Using drip irrigation or soaker hose systems on trees, shrubs and gardens can be more efficient than overhead watering, which loses water to evaporation or the wind.

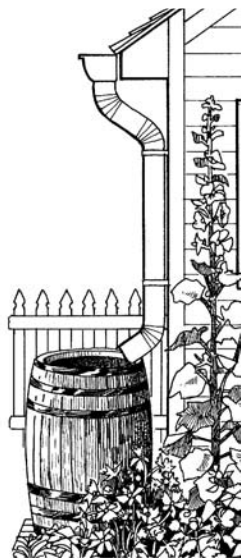

### Have you considered your yard and garden practices?

You can also improve water retention by improving your soil and cultural practices. Adding compost benefits both sandy and clay soils. It increases water-holding capacity in sandy soils and helps rain to soak in rather than run off of clay soils. Mulching decreases water loss by slowing evaporation from the soil and reduces weed competition for water and nutrients.

Using rain barrels to collect rainwater for your garden allows you to use the water gathered from gutter downspouts from your roof. A screen over the barrel will prevent mosquitoes from taking advantage of the water, too.

Washing with a hose uses about 50 gallons every 5 minutes. Sweeping a sidewalk or driveway rather than hosing it clean is a big water saver.

### Have you checked your outdoor plumbing?

How many times do you drive down the road and see sprinklers that are broken and running full tilt or misdirected and watering the street? These malfunctioning spigots simply waste water without providing benefit. Check hose couplings, outdoor spigots, hot tubs, pools and other equipment to ensure that you are not wasting water and your money. Also, Michigan winters commonly cause damage to undrained or unprotected outdoor piping. Draining lines that are not frost-protected will keep them from bursting.

Swimming pools with cracks can easily lose a lot of water. These pools need regular "topping up". Place a tape or mark at the water level to see how much it drops in 24 hours when the pool is unused. If water loss is less than ¼ inch per day, your pool is simply showing evaporative loss. If more, then check to determine where the loss is occurring. A recirculating pump is a water saver. Have it checked to make sure it is working properly.

Water features can be water wasters. Fountains send water into the air to be easily evaporated. Children's water slides with constant running water from a hose overwater a single spot on the lawn. Before choosing such features, consider the water usage impact.

## ✓ Assessment 2 – Risks Related to Outdoor Water Usage

Use the following assessment to rate your water conservation efforts. For each question, put your risk level (low, medium or high) in the column labeled “Your risk.” Choose the response that best fits your situation. Refer to the information in this chapter if you need help to complete this assessment.

	<b>Low risk/ recommended</b>	<b>Medium risk/ potential risk</b>	<b>High risk/ unsafe situation</b>	<b>Your risk</b>
<b>Plant types</b>	Drought-tolerant or site-appropriate plants chosen when selecting new plants for yard and garden.		No effort made to minimize use of water-thirsty plants.	
<b>Watering</b>	Sprinklers monitored and kept adjusted so only lawn or gardens are watered, not roads and storm drains.		Sprinklers poorly monitored and commonly watering unvegetated surfaces, causing runoff.	
<b>Irrigation</b>	Drip irrigation or soaker hose used for trees, shrubs and gardens. Water meter present on hose or water system that you turn on and off on the basis of conditions.	Drip irrigation or soaker hose used but without water meter.	Sprinklers used for trees, shrubs and garden. Irrigation done during windy and high evaporation (hot) periods of day. Watering system turned on automatically, and no provision made for plants’ needs and weather.	
<b>Mulch</b>	Organic mulch or weed preventive, water-permeable matting with mulch or stones used in gardens. Weeds removed.	No mulch used, but weeds removed.	No mulch used and weeds present.	
<b>Cleaning</b>	Driveways, sidewalks and impervious surfaces swept.		Water routinely used to hose off sidewalks, driveways and other impervious surfaces.	
<b>Downspouts</b>	Roof rainwater collected in a rain barrel for later use or directed toward trees and shrubs.		Roof downspouts allow rainwater to run off property.	
<b>Outside equipment</b>	No leaking couplings, faucets or hoses.		Leaks in pipes, couplings, faucets, hoses or attached equipment.	
<b>Swimming pool</b>	Water loss less than ¼ inch per day. Recirculating pump present and working properly.		Water loss greater than ¼ inch each day. Recirculating pump not present or not working.	
<b>A boxed risk level</b> indicates level required for Residential Environmental Assurance Program certification.				

### Responding to risks

As always, your goal is to lower your risks. Use the Action Checklist on the next pages to record the medium and high risks you have identified. Use recommendations in this chapter to help you make plans to reduce your risks.

## ✓ Action Checklist

Go back over the assessments and look for the medium and high risks you identified. Record them below. For each of your high risks, write down the improvements you plan to make. Use recommendations from this chapter and other resources to decide on actions you are likely to complete. A target date will keep you on schedule. You don't have to do everything at once, but try to eliminate the most serious risks as soon as you can. Often it helps to tackle the inexpensive actions first.

Write all high and medium risks here.	What can you do to reduce the risk?	Target date for action:
Example: Water faucet in laundry room dripping.	Change washer in faucet.	One week from today: May 15

## Resources

U.S. Environmental Protection Agency. [www.epa.gov](http://www.epa.gov)

Under “Quick Finder,” click on “Water,” then search “water conservation.”

U.S. Geological Survey. <http://ga.water.usgs.gov/edu/earthwherewater.html>

Water Conservation. [www.nrcs.usda.gov/feature/backyard/watercon.html](http://www.nrcs.usda.gov/feature/backyard/watercon.html)

Water Conservation Tutorial. <http://www.epa.gov/seahome/watcon.html>

or <http://cobweb.ecn.purdue.edu/~epados/farmstead/watcon/src/main.htm>

**“Water Conservation for Home and Yard.”** MSU Extension bulletin WQ 16.

**“Water Usage.”** Linda Heaton, Cooperative Extension Service, University of Kentucky. ENRI-117.

For information on clothes washers rated under the USEPA and Department of Energy ENERGY STAR® program, see the ENERGY STAR® webpage at: [http://www.energystar.gov/index.cfm?c=clotheswash.pr\\_clothes\\_washers](http://www.energystar.gov/index.cfm?c=clotheswash.pr_clothes_washers).

For information on dishwashers rated under the USEPA and Department of Energy ENERGY STAR® program, see the ENERGY STAR® webpage at: [http://www.energystar.gov/index.cfm?c=dishwash.pr\\_dishwashers](http://www.energystar.gov/index.cfm?c=dishwash.pr_dishwashers).

This chapter was written by Roberta Dow, Michigan State University Extension, Michigan Groundwater Stewardship Program, 2008.





If yours is like most homes, it is surrounded by lawns, gardens, shrubs and trees that require regular maintenance. This chapter examines the potential impact of yard and garden care on the environment and on your health.

**Topics:**

- ◆ Soil testing
- ◆ Fertilizers, pesticides and alternative control methods
- ◆ Lawn type and maintenance
- ◆ Ground covers and erosion protection
- ◆ Composting
- ◆ Conserving water

For more information about lawn and garden care specifically for those who live near water, refer to MSUE bulletin WQ-52, “Managing Shoreline Property to Protect Water Quality.” For more information on lawn care, refer to MSUE bulletin WQ-53, “Lawn\*A\*Syst,” and E0012, “Turf Tips for Water Quality.”



## Chapter 9. Caring for the Yard and Garden

### Why should you be concerned?

Your yard and garden, the natural setting of your home, might be the last places you would look for pollution problems. However, behind beautiful landscapes are activities that may threaten your health and the environment. Homeowners need to recognize that their practices may have a major impact on the environment. Problems occur when exposed soil washes away during a storm, harming wildlife habitat and choking waterways. If yard and garden chemicals are applied improperly, they may find their way into drinking water wells or pollute nearby lakes and streams. Closer to home, children are particularly vulnerable to pesticides that are stored or used without proper safety precautions.

Indiscriminate watering of lawns and gardens wastes large amounts of clean drinking water. Gasoline-powered mowers, weed cutters, leaf blowers and other devices make noise and pollute the air. A lawnmower powered by a two-cycle engine spews in one hour the same amount of exhaust as a car driven 350 miles. It may seem that your contribution to pollution is minor, but the effects of chemicals, soil loss and wasted water from hundreds of thousands of homes in your region can really add up.

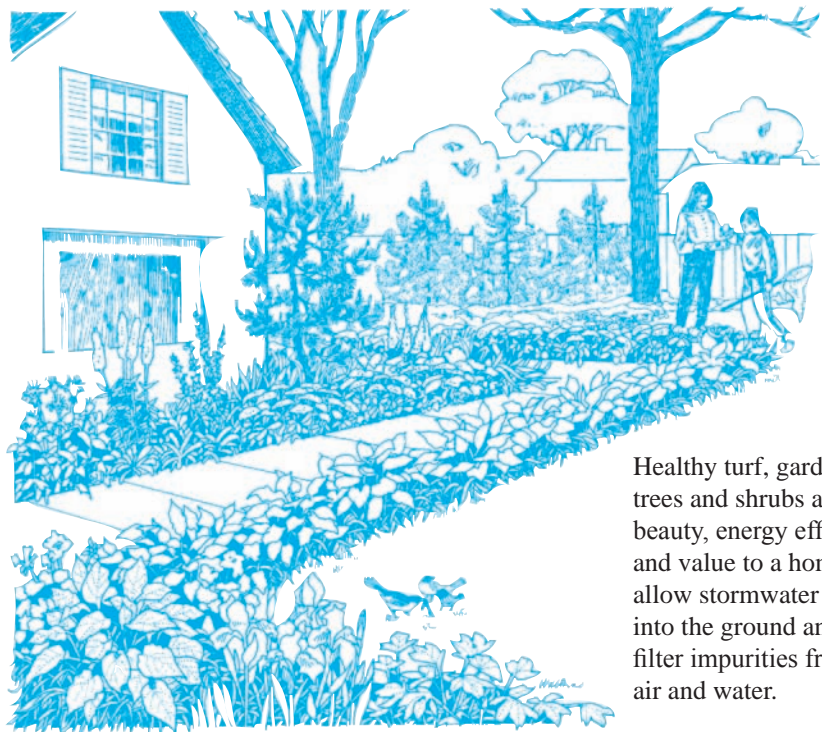

Healthy turf, gardens, trees and shrubs add beauty, energy efficiency and value to a home. They allow stormwater to soak into the ground and help filter impurities from the air and water.

## Are you using your time and money effectively?

Americans spend a lot of money on lawn and garden equipment and accessories, flowers, seeds and chemical products. They also dedicate many hours of leisure time to caring for their yards and gardens. These inputs may be wasted, however, if you do not follow environmentally sound practices. Develop a management plan (see example plan in Figure 1). Think about the cost and effort to replace lawns or plants damaged by overfertilization, poor cultural practices such as scalping or misuse of pesticides. Areas with eroded soil are not only unsightly but require hard work to return them to productive use. Imagine how much less time lawn care would take if you did not rake and bag grass clippings.

<b>Yard and Garden Management Plan</b>	
<b>Goals:</b>	<ul style="list-style-type: none"> <li>• Provide lawn play area for children.</li> <li>• Provide attractive setting for home with medium management and inputs.</li> <li>• Provide bird habitat.</li> </ul>
<b>Lawn:</b>	<ul style="list-style-type: none"> <li>• Plant grass type for site conditions (heat, cold, drought, shade, wear tolerances; fertilization needs; irrigation needs; and mowing height).</li> <li>• Fertility program:               <ul style="list-style-type: none"> <li>• Manage according to nutrient recommendations for lawn.</li> <li>• Two fertilizer applications per year (1 lb N or less per 1,000 sq. ft. per application).                   <ul style="list-style-type: none"> <li>– 1 spring application (after first mowing).</li> <li>– 1 fall application (around Labor Day).</li> </ul> </li> </ul> </li> </ul>
<b>Mowing:</b>	<ul style="list-style-type: none"> <li>• Set mower height at no less than 3 inches.</li> <li>• Leave grass clippings on lawn.</li> <li>• Remove no more than one-third of the length of grass blades at each cutting (mow approximately once per week).</li> </ul>
<b>Irrigation:</b>	<ul style="list-style-type: none"> <li>• In-ground system present. Water lightly as needed.</li> </ul>
<b>Scouting:</b>	<ul style="list-style-type: none"> <li>• Look for wear from games when mowing; move usage if wear showing.</li> <li>• Scout for pest and disease problems (once per week).</li> </ul>
<b>Gardens:</b>	<ul style="list-style-type: none"> <li>• Test soil (every 3 years).</li> <li>• Fertilize according to nutrient recommendations.</li> <li>• Add compost when working up beds before planting.</li> <li>• Select native and pest/disease-resistant, low-maintenance, adapted, hardy perennial plants – include plants that provide year-round visual enjoyment as well as plants that provide bird habitat and food.</li> <li>• Select and site plants so that pruning is not an annual need.</li> <li>• Inspect plants for pests/disease prior to planting.</li> <li>• Develop IPM plan.</li> <li>• Plant perennials properly.</li> <li>• Mulch beds to prevent moisture loss and discourage weeds.</li> <li>• Keep mulch away from stems and trunks of woody plants.</li> <li>• Add mulch as needed over the years.</li> <li>• Automatic watering will be done according to a moisture meter in the soil.</li> </ul>

Figure 1: Example of a short yard management plan.





You can have low-maintenance lawns without losing the well-kept appearance of your home. Good management practices, such as raising the mowing height, not only benefit the environment—they can save you time and money.



When choosing plants for your yard, evaluate their adaptability for your site first. Careful selection can provide great choices for a low-input (fertilizer, pesticide, water, extensive maintenance), sustainable landscape plan. **Native** plants that are adapted to your particular area have already demonstrated that they are survivors with your geography, climate and native pests. Native plants also provide food sources and habitat for native wildlife.

Whether using native or non-native species, avoid aggressive or invasive plants. Invasive plants outcompete other vegetation and can disrupt the natural balance of plant and animal resources in the area.

### Managing your lawn, garden and landscaping

Attractive landscaping can greatly increase the value of your home and provide you with much pleasure. A properly designed and maintained yard can help reduce soil erosion and water runoff, stabilize shorelines and increase soil water retention. First, determine the goals for your lawn and garden and include them in your management plan. Do you desire a natural yard with locally adapted or native plants, perhaps with little lawn and few annual plantings; a heavy usage recreation area for the family; or a highly manicured lawn with formal plantings of carefully pruned shrubs and beds of annuals? The inputs (cost, labor, etc.) needed for these vary greatly, depending on your goals. Normal applications of lawn and garden products generally pose few problems. Poor maintenance, however, either through neglect or excessive

chemical applications, can lead to disruption of the natural environment, soil problems, polluted runoff and unsafe well water.

### Has your soil been tested?

A soil test is the first step in determining how much and what type of fertilizer is needed for the plants you are trying to grow. Adding fertilizer without first testing your soil is like taking medicine without knowing that you need it. Your soil already has some of the nutrients—such as calcium, phosphorus and potassium—needed for good plant growth. It is important to find out how much of each nutrient is present. Include your test results in your management plan. Soil testing takes the guesswork out of fertilizer use.

Figure 2: Soil test results from MSU soil testing laboratory.

MICHIGAN STATE UNIVERSITY		MICHIGAN STATE UNIVERSITY SOIL AND PLANT NUTRIENT LABORATORY EAST LANSING, MICHIGAN 48824-1325 (517) 355-0218								
SOIL TEST REPORT FOR:			ADDITIONAL COPY TO:							
TRAVERSE CITY MI 49684										
DATE	LAB #	COUNTY	Previous Crop	ACRES	FIELD ID	SOIL				
5/31/2007	68973	Grand Traverse			1	Mineral				
SOIL NUTRIENT LEVELS		Below Optimum	Optimum	Above Optimum						
Soil pH 6.6	Lime Index 72.0									
Phosphorus (P)	19 ppm									
Potassium (K)	40 ppm									
Magnesium (Mg)	84 ppm									
ADDITIONAL RESULTS:				Optional Tests:						
Calcium (Ca) ppm	CEC (meq/100 g)	% of Exchangeable Bases		B	Cu	Mn	Zn	Fe	Organic Matter %	Nitrate-N ppm
684	4.2	K	Mg	Ca						
		2.4	16.6	81.0						
RECOMMENDATIONS FOR: <i>Lawn, bluegrass</i>										
Limestone:	NONE									
Nitrogen (N):	2.5-5 lb/1000 sq ft									
Phosphate (P <sub>2</sub> O <sub>5</sub> ):	NONE									
Potassium (K <sub>2</sub> O):	3.2 lb/1000 square feet									
MESSAGES										
Maximum single nitrogen application is 1 lb/1000 sq. ft. Nitrogen rate may be decreased 20 to 40 % if clippings are returned. For shaded grass decrease nitrogen rate by % and apply primarily in fall.										
Test Methods: 1- 1:1 soil:water pH, 2- Bray P1 Extractant, 3- IN Ammonium Acetate Extractant										

### Key to understanding a soil test:

**Nitrogen (N)**—Nutrient used in largest amount by plants. Necessary for protein formation. Because N is not static in soil (may be lost to air, water, microbes and plants) and is affected by temperature, it is not measured in the general soil test.

**Phosphorus (P)**—Nutrient associated with root growth and flower development. Test results are expressed in pounds per acre and reflect relative availability of phosphorus for plant growth rather than total P in the soil.

**Potassium (K)**—Nutrient second only to nitrogen in amount absorbed by plants. Associated with overall vigor, stress and disease resistance, stem strength and root growth.

**Magnesium (Mg)**—Essential for photosynthesis, the process by which plants make sugars utilizing energy from the sun.

**Calcium (Ca)**—Important in plant cell wall formation.

**pH**—Measure of acidity or alkalinity of the soil. Influences the availability of nutrients in the soil. Adding certain materials containing sulfur reduces soil pH (makes soil more acidic). Adding limestone (calcium or magnesium) raises the pH (“sweetness” of the soil—makes it more alkaline/less acidic).

**Cation exchange capacity (CEC)**—A measure of the soil’s ability to hold or exchange positively charged plant nutrients. This affects fertilizer management, nutrient loss and groundwater contamination. CEC depends on the type and amount of clay and the amount of humus (organic matter) in the soil. Generally, low CECs indicate low clay or humus content, and high CECs indicate more clay or humus. These soils usually don’t lose nutrients as quickly as sandy soils.

Check with your local Michigan State University Extension office about testing your soil. A standard soil test will determine the amounts of phosphorus, potassium, calcium and magnesium, the ion exchange capacity and pH (Figure 2). You receive a lab report for your sample and a fertilizer recommendation based on your soil test results and the plants you wish to grow. Soil tests should be conducted at least every three years.

It is important to note that most Michigan soils contain ample amounts of phosphorus, so additional phosphorus is unneeded and can be harmful to surface water. Addition of phosphorus is necessary only when soil tests show phosphorus deficiency or when seeding a new lawn or establishing sod.

### What fertilizers do your lawn and garden need?

Your lawn and garden goals and the soil test results will determine fertilizer need and amount. Even if you hire a lawn care service or plan to use natural fertilizers such as compost, cow manure or other soil amendments, soil testing is important. It is particularly important for waterfront property, where phosphorus should be avoided unless applications are indicated by your soil test. If you live on a street that has a storm drain, think of yourself as living on a streambank, because you are likely connected to nearby surface water by underground drainage pipes. Look for earth-friendly or lake-safe fertilizers to promote lake and river protection. These fertilizers contain a high percentage of slow-release nitrogen and little or no phosphorus, and are free of pesticides (see “Resources” at the end of this chapter).

Nitrogen is the key plant nutrient for promoting a healthy lawn. Applied at the right time and in the right amount, it will be a major factor in achieving your goals. Applied at the wrong time and in the wrong amount, it will make conditions worse by damaging the lawn and increase the potential for nutrient movement off your property, either as runoff or in movement of water downward toward the groundwater. If only one fertilizer application is planned per year, make it a fall application. If a spring application is also planned, delay putting fertilizer on until after the first mowing. Sweep excess fertilizer from walks and driveways back onto the grass before it is washed away by rain. Clover in a yard may substitute for nitrogen fertilizer. This and other pea and bean family plants (legumes) take nitrogen from the air and fix it in the soil, where other plants can use it.



### What do the three numbers on a fertilizer label mean?

By law, fertilizer bags contain three numbers (fertilizer grade), which indicate the nitrogen, phosphorus and potassium content in that particular fertilizer. The first number indicates the percentage by weight of elemental **nitrogen (N)**. The second number indicates the percent available **phosphate (P<sub>2</sub>O<sub>5</sub>)**. The third number indicates the percentage of water-soluble **potash (K<sub>2</sub>O)**.

### How much fertilizer do you need?

Once you know what soil nutrients are present in your soil, you must also know the nutrient requirements of each plant type you are trying to grow. To obtain plant nutrient recommendations, contact your local MSU Extension office.

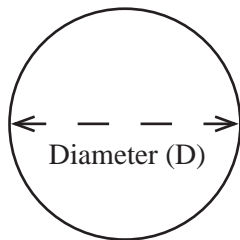
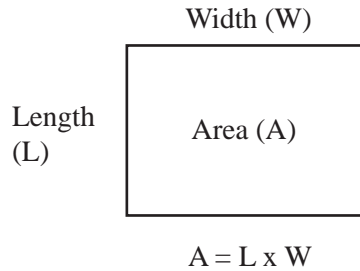

$$A = \pi(\frac{1}{2} D)^2$$

$$= 3.14 \times (\frac{1}{2} D)^2$$

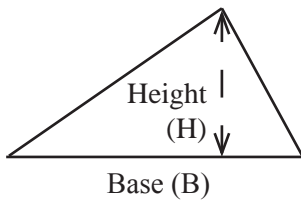

$$A = \frac{1}{2} B \times H$$

Figure 3: Calculating areas (A) of variously shaped lawns or gardens.

Before applying fertilizer, you need to know the size of the area (Figure 3) you wish to fertilize so that you know how much fertilizer you will need. Over- or misapplication of fertilizers can pollute water resources, kill your plants, and waste time and money. Be sure to leave a buffer strip near lakes and rivers that is neither mowed nor fertilized to prevent excess nutrients from degrading water quality. Planting native plants, which have deeper roots than turf, in this area will also help to filter excess fertilizer, prevent soil erosion and filter pollutants.

### Are you taking proper care of your lawn?

It will be easier to keep your lawn healthy if the type of grass is suited to your growing conditions—rainfall, temperature, soil type and available sunlight. Contact your local MSU Extension office for a list of recommended grasses for your conditions. Proper mowing height is fundamental to a healthy lawn. Taller grass conserves water, prevents weeds and promotes drought tolerance. A mowing height of 2.5 to 4 inches is recommended. It is also recommended that no more than one-third of the total leaf surface is removed at each mowing. Grass clippings should be left on the lawn—in many cases, they supply enough natural fertilizer that only minimal additional fertilizer is needed to keep your lawn healthy. Clippings are a source of nitrogen, so you may be able to reduce fertilizer needs by 25 percent or more. Switching to a human- or electric-powered mower can cut down air and noise pollution. If you reduce your lawn size and grow plants that require little maintenance, such a mower can be practical.

If you hire someone to take care of your lawn, you can still do your part to make sure that your lawn is managed in an environmentally friendly way. Research lawn care companies in your area that reduce the overuse and misuse of fertilizers and pesticides in their services and that pay particular attention to avoiding these inputs from degrading our water resources. Such “healthy lawn” options may also include soil testing at the beginning of the season, use of slow-release fertilizers, reduced nitrogen applications, low- or no-phosphorus fertilizer options, providing customers with maintenance and cultural practices related to mowing and watering, and spot treating weeds only when necessary.

## Oh, no! A spill!

Spills do happen. The trick is to be prepared. When a spill occurs, follow the five C's of spill response:

1. **Caution:** Always assess the dangers of the spill first. If the spill cannot be controlled or contained without endangering life or safety, then immediately call 911.
2. **Control:** If possible, control the source of the spill – shut off valves, plug holes or set containers upright.
3. **Contain:** Stop the spread of the spill to groundwater, surface water, wells or storm drains by using a shovel to make a soil berm or by applying an absorbent material such as cat litter.
4. **Communicate:** Contact the appropriate authorities, if necessary:
  - a. Danger to health or safety: emergency number 911.
  - b. Danger to groundwater or surface water: Michigan Department of Environmental Quality Pollution Emergency Hotline: 1-800-292-4706.
5. **Cleanup:** For a dry spill, sweep up product and dispose of properly or use as intended. For a wet spill, use cat litter, activated charcoal or sawdust to absorb the chemical, then sweep up and dispose of the material properly. Never wash a spill down a drain. Most drains lead directly to lakes, rivers or streams.

## Be prepared—make a spill kit!

A spill kit is a very handy item to keep around the house should chemicals leak or spill. A spill kit contains items to assist in the cleanup of dry or wet spills in one handy box.

- ◆ Plastic storage tote – Holds materials in one location.
- ◆ Safety goggles – Protect eyes, one of the most sensitive areas on the human body.
- ◆ Chemical-resistant gloves – Nitrile gloves are suitable for most household chemicals; work gloves or gloves with linings do not provide adequate protection.
- ◆ Broom and dust pan – To sweep up dry spills.
- ◆ Garbage bags – For easily handling of leaky or spilled material.
- ◆ Cat litter, oil absorbent or sawdust – To soak up liquid spills before sweeping and disposing.
- ◆ Emergency telephone numbers – To seek help if needed.

**Some types of pesticides: (chemicals that kill or repel pests)**

- ◆ Insecticides
- ◆ Herbicides
- ◆ Fungicides
- ◆ Rodenticides
- ◆ Nematicides
- ◆ Bactericides
- ◆ Algaecides



**Are you using and applying pesticides wisely?**

Although hand removal of weeds, insects and other pests is safest for the environment and your health, chemical pesticides—if properly used—may pose only minimal risk. The key is doing your homework before you start treatment. Correctly identifying the pest is the first step. Many plant problems are not caused by insects or disease but are related to temperature extremes, waterlogged soil, drought, lawnmower damage and overuse of chemicals. Learn when and where pesticides are needed. Apply them only where pests occur. Select the least toxic chemicals or ones that break down quickly into less harmful substances. Check with your local MSU Extension office or garden supply store for more information.

Remember that pest prevention is simpler and cheaper than pest control. Selecting pest/disease-resistant plants and keeping them healthy reduces potential pest problems. Be sure to ask yourself if, for the sake of clean groundwater and an environment with fewer chemicals, you can tolerate a few more weeds and bugs around your home.

Apply lawn pesticides only when needed and in favorable weather conditions. Always read the product label—it's the law. Avoid applications of pesticides to the whole yard unless it's critical. For example, why use a weed-and-feed product on the whole lawn if you have only a few weeds? Spot applications directed to the pest problem avoid overuse. Keep kids and pets off the treated lawn per label instructions.

**Do you use integrated pest management?**

Practicing integrated pest management (IPM) in your yard to maintain healthy plants involves the use of a variety of strategies to control pest and disease problems. IPM involves three methods of control: cultural, biological and chemical. Weeds can be controlled by hand pulling or hoeing, and you can pick bugs off of vegetables and garden plants. Clean up diseased and pest-infested debris to limit infestations and reduce future problems. Using natural predators to control pests is another method. You can release beneficial insects and microorganisms that feed on pest insects in your garden or create habitat for pest predators and parasites (see “Resources” at the end of this chapter). When you have no other choice, try to find non-toxic or low-toxicity chemicals such as insecticidal soaps. Follow directions carefully, and mix only the amount you need. For IPM to work, you will have to give more time and attention to your yard and garden. Consider IPM strategies for your various plants in your management plan.



**More yard and garden tips that protect water resources**

- ✓ Always store pesticides in original containers.
- ✓ Store pesticide containers out of reach of animals and children, preferably in a locked cabinet.
- ✓ Always read and follow pesticide and fertilizer label instructions.
- ✓ Calibrate pesticide and fertilizer applicators to deliver correct rates. See owner's manual.
- ✓ Carefully measure area to be treated and products used.
- ✓ Avoid fertilizer and pesticide applications when heavy rains are forecasted. Delay irrigation after applications unless recommended on the label.
- ✓ Apply pesticides at the appropriate time in the pest or disease life cycle.
- ✓ Triple-rinse empty pesticide containers; drain the rinse water into your sprayer tank.
- ✓ Spot treat pest problems, when possible.
- ✓ Put together a spill kit. Avoid spills. Clean up spills quickly if they occur.
- ✓ Take unwanted or unusable pesticides to local Clean Sweep site or hazardous waste collection program. Check if your local program accepts cleanup wastes if you had a spill.

✓ **Some IPM strategies**

Strategy	Category of control	Example(s) or comments
<b>Plant health</b> —healthy, unstressed plants are less susceptible to pests than plants under stress.	Cultural	Use resistant varieties appropriate for the site and conditions. Introduce only pest- and disease-free plants to your garden.
<b>Sanitation</b> —removing or reducing the number or source of the pests or disease.	Cultural	Remove dead, dying or insect-invaded plant parts or plants; rake up fallen diseased leaves; hand pull or cultivate to remove weeds; pick off snails, slugs or insects.
<b>Barrier</b> —preventing access.	Cultural—mechanical	Put sticky material around a tree trunk or limb to prevent movement of caterpillars or scale insect crawlers or other pests; put cans open at both ends around your transplanted tomato or other tender plants to prevent cutworm damage. Use bird nets and prevent grass in flower gardens with edging.
<b>Traps</b> —many types are now available for a variety of insect problems.	Cultural—mechanical	Sticky boards and traps with insect sex attractants can be purchased for capturing specific insects. Some lures attract only one sex. These may be used to aid in proper timing of a chemical application. Homemade traps for snails or slugs can be as simple as a pie pan embedded at soil level and filled with beer, or a grapefruit half partially hollowed out and turned upside-down on the ground so snails and slugs can collect under it. Trap crops (more attractive to the pest) may also be used to concentrate the pest or lure it away from other crops.
<b>Crop rotation</b> —rearranging where you plant related annuals—vegetables or flowers—in your garden.	Cultural	Planting the same type of plant in the same place year after year increases the pest problems for that plant in that spot. For some soil-borne disease or pest problems, rotation is a homeowner’s only control option.
<b>Microbial insecticides</b> —use of bacteria or fungi to control insect problems.	Biological	Use of bacteria to control caterpillars (Bt or <i>Bacillus thuringiensis</i> ) or Japanese beetle grubs ( <i>Bacillus popillae</i> ).
<b>Insect predators</b> (work best in controlled environments such as greenhouses)	Biological	Releasing adult and larval stages of lady beetles to control insects such as aphids, scale, mealybugs and whiteflies. Release of predatory mites to control plant-feeding mites.
<b>Botanical insecticides</b> (plant-derived)	Chemical	Planting marigolds to discourage nematodes in the soil. Pyrethrin-based insecticide derived from mums. Note: natural or plant-derived does not mean these products are non-toxic or non-chemical.
<b>Synthetic pesticides</b>	Chemical	Range of widely available chemical-based products to treat mite, insect, weed and disease problems.



## Do your landscape practices help prevent soil erosion?

Like pesticides and fertilizers, soil washed away by rain can pollute streams, lakes or bays. Even if you do not live near water, soil will be carried there by runoff from storms. Gardens, sparse lawns and construction sites with areas of bare soil, especially on sloped land, are prone to soil erosion. You can protect soil and reduce erosion by planting ground cover vegetation or using mulch and/or landscape fabric. On steep slopes where mowing grass is a problem, leave the natural vegetation or plant a vigorous ground cover. Building terraces or retaining walls on slopes can also help prevent soil loss. Choose plants suited to the area and insect- and disease-resistant.

## Do you make compost?

**Composting** is a cost-effective method by which bacteria and fungi decompose yard waste (leaves and grass clippings), vegetable scraps from the kitchen, etc., to yield a soil-like product which is called **humus** or **compost**. Yard waste is no longer permitted in landfills. Composting is an important and environmentally conscious way of recycling and improving the soil. Successful composting does require a balance of certain materials, which are detailed in “Ingredients to create a compost pile” below. Composting takes advantage of nature’s recycling system for breaking down plant and other organic materials. You can simply put yard wastes in a pile, or you can install homemade or store-bought bins. In addition to yard waste, you can add vegetable trimmings and fruit peels from your kitchen. Your compost pile will remain relatively odor-free if it is turned and aerated regularly.

Finished compost is valuable. It can be mixed into garden soil or spread on lawns as a slow-release source of nutrients. One word of caution: animal manures may contain high levels of nitrogen, and manures from various types of animals have different levels. If manure is left in piles exposed to the weather, nitrogen-rich runoff may result. If you mix manure from horses, sheep, cows or other plant-eating animals into your compost, be sure to add plenty of leaves, straw, sawdust or pulled weeds to keep concentrations of nitrogen and other nutrients low. This will help prevent contamination of groundwater. Do not put pet wastes (from cats and dogs) in compost piles because of potential parasite and disease problems. Try to locate compost piles at least 50 feet from your well and from lakes and rivers. Check with your local MSU Extension office, garden stores, the library and your neighbors for ideas.



### Ingredients to create a compost pile:

- ✓ **Green/moist:** Materials containing a high nitrogen content, such as grass clippings, coffee grounds, vegetable scraps.
- ✓ **Brown/dry:** Materials high in carbon, such as dry leaves, straw, wood chips and newspaper.
- ✓ **Microorganisms:** Naturally found in soil.
- ✓ **Water.**
- ✓ **Air.**

### Items to keep out of the compost pile:

- ✓ Pet waste.
- ✓ Meat, eggs, dairy products and other animal products.
- ✓ Grease, oils or foods cooked with oils.
- ✓ Invasive weeds and seeds.
- ✓ Diseased plant materials.

## Do your yard care practices save water?

The average American’s indoor and outdoor water use is approximately 200 gallons of water each day. Approximately half of that water is used for landscaping and gardening, depending on climate and time of year. This is an immense amount of clean water—and only a small portion is actually used by your plants. If you convert your landscape to plants adapted to your area and weather, you will take the biggest step in conserving water. In dry, sandy sites, you may choose native plants that are drought-tolerant. Some perennials are hardier because their roots grow deeper than those of annual plants, requiring little or no watering once established. For more information on water conservation, see Chapter 8, “Conserving Water around Your Home.” See Chapter 7 for more information on creating rain gardens for stormwater management.

### Watering wisely

Most plants can tolerate at least short dry periods. Watering should be timed to meet the biological needs of the plants. Watering slowly and deeply helps non-turf plants develop deep roots; in the long run, your plants will need less frequent watering. Plants can absorb only so much water. Overwatering wastes water and can injure certain plants. Turf likes light, frequent watering—0.2 inch every other day, depending on weather—typically .5 to 1.5 inches of water per week (Figure 4). An alternative to watering lawns is to allow established cool-season lawn grasses to go dormant during the hot, dry summer rather than irrigating. This is a natural part of their life cycle. Drip irrigation systems and soaker hoses are useful for gardens—they deliver water to the intended plants efficiently. The time of day when you irrigate matters, too. Watering prior to the hottest part of the day helps reduce stress on turf.



Figure 4: Sprinklers vary. To determine how much water your sprinkler is delivering, place a can with straight sides in the sprinkler path. Measure with a ruler the amount of water delivered in a given time period (example: 1 hour).

## ✓ Assessment – Yard and Garden Care

The assessment on the next page will help you identify potential environmental risks related to your yard and garden maintenance practices. For each question, put your risk level (low, medium or high) in the column labeled “Your risk.”

Although some choices may not correspond exactly to your situation, choose the response that best fits. Refer to the previous pages for information needed to complete this table.



	<b>Low risk/ recommended</b>	<b>Medium risk/ potential hazard</b>	<b>High risk/ unsafe situation</b>	<b>Your risk</b>
<b>Fertilizers</b>	Soil is tested for nutrients, and fertilizer is used as recommended.	Soil not tested, but fertilizer label is followed.	Soil is not tested. Fertilizer is used without regard to area and/or label instructions.	
<b>Pesticides</b>	Non-chemical or low-toxicity methods are first considerations for pest control. IPM used.	Chemicals are used according to label instructions.	Chemicals are used without regard to label instructions or conditions.	
<b>Lawn (turf) type and maintenance</b>	Turfgrass is suited to soil type, available sunlight and climate. Grass is regularly mowed to 2 1/2 – 4 inches in height. No more than one third of grass leaf removed at single mowing.	Turfgrass is suited to the site but is over-fertilized and mowed shorter than 2 1/2 inches.	Grass type is not suited to available light, soil type or climate. Grass is pest-prone and mowed shorter than 2 1/2 inches. More than one-third of leaf removed at single cutting.	
<b>Ground cover and other plantings</b>	Ground covers, flowers, trees and shrubs are planted to reduce soil erosion. Native or pest- and disease- resistant, hardy varieties selected.	A slow-spreading ground cover is used.	A hilly landscape or lack of ground cover allows soil erosion. Plants chosen require high maintenance and chemicals to survive.	
<b>Composting</b>	The compost pile is well-maintained: it is aerated regularly and contains yard waste, vegetable food scraps and a nitrogen source such as manure.	The compost pile is poorly maintained: it is not aerated or lacks the proper mix of materials. Dog, cat and other pet wastes are added to the pile.	The compost pile is poorly maintained: it contains excessive high-nitrogen sources, greasy meat or diseased plant material and is not turned regularly. The pile is less than 50 feet from a shallow well or surface water.	
<b>Water requirements of plants</b>	Grass, flowers, trees and shrubs are able to survive with normal rainfall.	Landscape plants require light to moderate watering.	Heavy watering is required to keep the lawn and other plants alive.	
<b>Watering methods</b>	Watering done in the morning, only as needed. Low-water-use devices such as soaker hoses used for gardens. Sprinkler system is monitored.		Watering is done by time clock or daily without regard to need or weather conditions. There is excessive water runoff.	
<b>Yard/garden management plan</b>	Management plan present, clearly indicating goals and expectations.		No management plan present.	

**A boxed risk level** indicates level required for Residential Environmental Assurance Program certification.

### Responding to risks

Your goal is to lower risks. Complete the Action Checklist to help you make plans to reduce your risks.



## **Resources:**

Contact your local Michigan State University Extension office for information on soil testing, lawn and garden care, composting, plant and pest hotline and diagnostic services, the MSU Master Gardener volunteer program and the Michigan Master Composter program. Also contact conservation districts, local garden centers, lawn or landscaping services. Local watershed councils are valuable sources of information on lakescaping (for those who live near water), watershed-friendly lawn and garden care, and stormwater management, including rain gardens.

### **MSU educational materials**

MSU Educational Materials Distribution Center (Extension bulletins).  
[www.emdc.msue.msu.edu](http://www.emdc.msue.msu.edu)

### **Composting**

Resource Conservation Manitoba Compost Action Project.  
[www.resourceconservation.mb.ca](http://www.resourceconservation.mb.ca)

Urban/Suburban Composter: Complete Guide to Backyard, Balcony and Apartment Composting. 1994. Cullen, Johnson and Leyerle. St. Martins Press, New York, N.Y. ISBN No. 0312105304.

### **Earth-friendly or lake-safe fertilizers**

[www.socwa.org](http://www.socwa.org) Click on "Lawn & Garden."

### **Soil testing**

Contact your local MSU Extension office or the MSU Soil Lab at:  
[www.css.msu.edu/SoilTesting.cfm](http://www.css.msu.edu/SoilTesting.cfm)

MSU Extension soil web pages for consumers.

[www.msue.msu.edu/monroe](http://www.msue.msu.edu/monroe) Click on "Soil Test Website" in upper right corner.

### **Lawn care**

MSU turfgrass website includes maintenance, renovation, pest management and weed identification bulletins and web resources.

[www.turf.msu.edu](http://www.turf.msu.edu)

LawnCare 101 DVD (E2937) available from your local MSU Extension office or turfgrass website above.

Turf Tips for Water Quality. MSU Extension bulletin E0012.

### **Hiring a lawn care contractor**

A Guide to Selecting a Lawn Service: Questions to Ask.

[www.socwa.org](http://www.socwa.org) Click on "Lawn & Garden."

Choosing a Lawn Care Company: Guidelines on making informed decisions to help create and maintain a healthy lawn. MSU Extension bulletin E2771.

### **Landscaping for water quality**

Kellogg Biological Station Shoreline Management Demonstration and Information.

[www.kbs.msu.edu/extension/ShorelineManagement.htm](http://www.kbs.msu.edu/extension/ShorelineManagement.htm)

Lakescaping for Wildlife and Water Quality. 1999. Carol Henderson, Minnesota Department of Natural Resources. MSU Extension bulletin WQ57.

Restore the Shore CD-ROM. 2002. Minnesota Department of Natural Resources. Available from Minnesota's Bookstore at 1-800-657-3757 or [www.comm.media.state.mn.us/bookstore/bookstore.asp](http://www.comm.media.state.mn.us/bookstore/bookstore.asp)

Landscaping for Water Quality. DEQ. Jane Secord. [www.deq.state.mi.us/documents/deq-wb-nps-Landscaping-for-Water-Quality.pdf](http://www.deq.state.mi.us/documents/deq-wb-nps-Landscaping-for-Water-Quality.pdf)

Life at the Water's Edge [www.epa.gov/ecopage/aquatic/lifedge.pdf](http://www.epa.gov/ecopage/aquatic/lifedge.pdf)

### **Native plants**

Michigan Native Plant Producers Association (MNPPA). [www.mnppa.org/](http://www.mnppa.org/)

Wild Ones—Landscaping with Native Plants (fourth edition). [www.epa.gov/greenacres/wildones](http://www.epa.gov/greenacres/wildones)

### **Integrated pest management (IPM)**

[www.ipm.msu.edu/turf.htm](http://www.ipm.msu.edu/turf.htm)

Attracting Beneficial Insects with Native Flowering Plants  
MSU Extension bulletin E2973.

What's Bugging You—How to Deal with Insects around Your Home  
MSU Extension bulletin E2649.

### **Clean Sweep program**

For unwanted pesticides and mercury. Program contacts list: [www.michigan.gov/mda](http://www.michigan.gov/mda). Enter "clean sweep contact information" into search bar.

### **Pesticides**

National Pesticide Information Center, Oregon State University. [www.npic.orst.edu](http://www.npic.orst.edu) or call 1-800-858-7378.

Poison Control: 1-800-222-1222.

### **Stormwater management**

7 Simple Steps to Clean Water: Tip cards on protecting water resources, including proper use of fertilizers and pesticides. [www.semco.org](http://www.semco.org)

This chapter was written by K. Marc Tefteau, regional Extension specialist, Wye Research and Education Center, and Ray Bosmans, regional Extension specialist, Home and Garden Information Center, University of Maryland Cooperative Extension Service, and adapted for Michigan by Roberta Dow, Greg Lyman, L. Andrew Norman and Jim Bardenhagen, Michigan State University Extension. Updated in 2008.





**K**eeping your well water free of harmful contaminants is a top priority for your health and the environment. This chapter helps you examine how you manage your well and how activities on or near your property may affect water quality. This chapter covers:

### 1. Well location

- ◆ How close is your well to potential pollution sources?
- ◆ How might your soil type affect water quality?

### 2. Well construction

- ◆ Do you know the age of your well, its depth and how it was installed?
- ◆ Is your well casing properly sealed?

### 3. Water testing and unused wells

- ◆ Have tests of your well water revealed any potential problems?
- ◆ Are abandoned wells on your property sealed to prevent movement of contaminants?

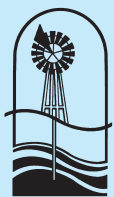

Michigan  
Groundwater  
Stewardship  
Program

**MICHIGAN STATE**  
**UNIVERSITY**  
**EXTENSION**

## Chapter 10. Protecting Your Drinking Water Well

### Why should you be concerned?

The two sources of drinking water are surface water and groundwater. In metropolitan Detroit, for example, more than 3 million urban and suburban residents depend on surface water for their municipal drinking water supply. This surface water is obtained from Lake Huron and the Detroit River. Nationwide and in Michigan, about 95 percent of rural residents use groundwater for their drinking water. Private wells, tapping into local groundwater sources, provide clean, safe drinking water (Figure 1). However, if these wells are improperly constructed or poorly maintained, they can provide a pathway for fertilizers, bacteria, pesticides or other toxins to contaminate the water supply. Once in groundwater, contaminants can flow from your property to a neighbor's well or from beneath a neighbor's property to your well.

These contaminants, which often have no odor or color, are difficult and expensive to remove. Your only options may be to treat the water after pumping, drill a new well or obtain water from another source.

Some rural residents use other water sources such as lakes, rivers or cisterns for their drinking water. Public health officials advise against using these unsanitary water sources for drinking water. Additional information on how to safeguard all water resources may be sought from local Extension educators, local conservation district staff members, state and federal environmental agencies, local health department offices and the library.

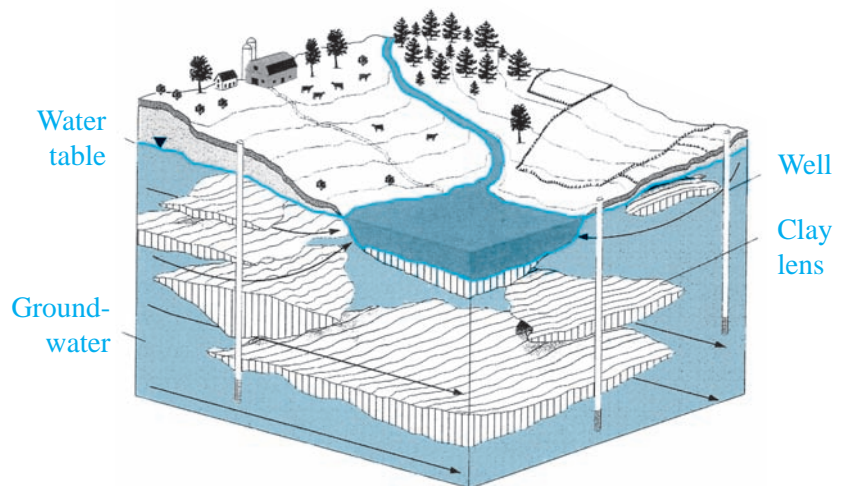

Figure 1: Cross-section of land showing land surface features, water table, clay and sand layers, and wells. "Understanding Groundwater." Institute of Water Research/Center for Remote Sensing, MSU.

## Part 1 – Well Location

Your well's location in relation to other features on or near your property will determine part of your potential pollution risk. How near your well is to sources of pollution and whether the well is downhill (downgradient) from these sources are the primary concerns. At the end of Part 1, fill out the assessment table to determine your possible well location risks. The information below will help you answer the questions in the assessment.

### What pollution sources might reach your well?

Groundwater is water below the land surface that completely fills the pore spaces of soils and void spaces of rock formations. Whether groundwater is just below the surface or hundreds of feet down, the location of your well on the land surface is very important. Installing a well in a safe place takes careful planning and consideration of such factors as where the well is located in relation to potential pollution sources. When possible, the well should be located where surface water (storm runoff, for example) drains away from it. If a well is downhill from an aboveground leaking fuel storage tank or an overfertilized farm field, it runs a greater risk of contamination than a well on the uphill side of these pollutant sources. In areas where the water table is near the surface, groundwater often flows in the same direction as surface water. Surface slope, however, does not always indicate the direction a pollutant might flow once it gets into groundwater. Changing the location or depth of your well may protect your water supply but not the groundwater itself. Any condition likely to cause groundwater contamination should be eliminated, even if your well is far removed from the potential source.

Most states require that new wells be located a minimum distance from sources of potential pollution (Figure 2). The Michigan Water Well Construction and Pump Installation Code provides minimum well isolation distances from various contamination sources and buildings. In general, it is best to provide as much separation as possible between your well and any potential contamination source—at least 50 feet. Additional distances are needed for some contamination sources. For example, agricultural chemical/fertilizer storage or preparation areas should be set 150 feet from any residential water well, and fuel storage (both buried and aboveground tanks greater than 1,100 gallons without secondary containment) should be 300 feet from the well. Separating your well from a contamination source may reduce the chance of pollution, but it does not guarantee that the well will be safe.

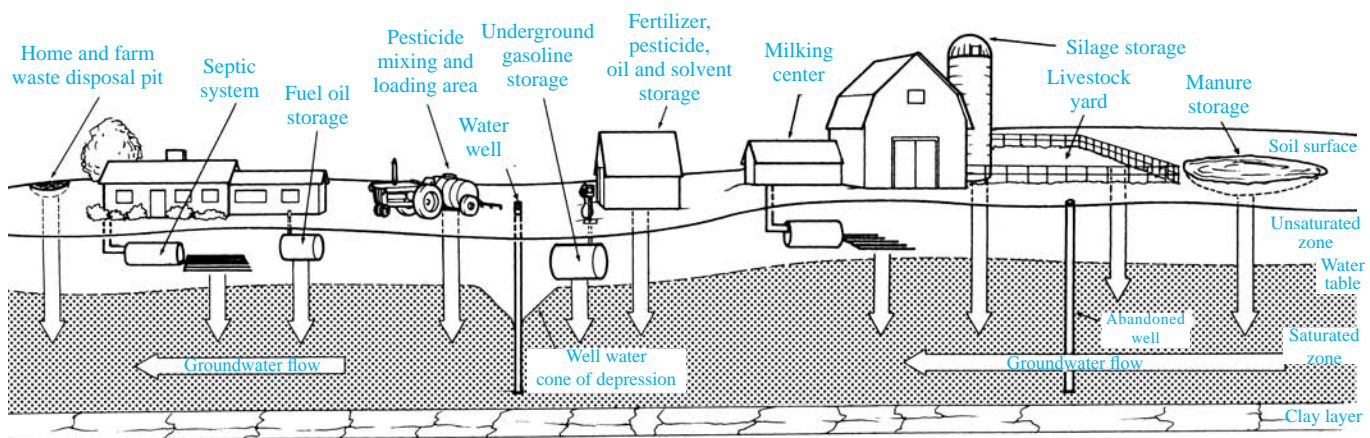

Figure 2: Illustration of possible sources of groundwater contamination. Common to most farmsteads are sources of nitrate contamination such as manure, milking center wastewater and nitrogen fertilizers, which must be properly managed to protect groundwater. Likewise, city dwellers have to consider their animal waste, chemical storage and fertilizers to protect their city water supply.

## What's underground? Soil and bedrock type, distance to the water table

Pollutant risks are greater when the **water table** (top of the saturated area) is near the surface because contaminants do not have to travel far to reach the water. Contamination is more likely if soils are thin (a few feet above bedrock) or if they are highly porous (sandy or gravelly). If bedrock below the soil is fractured (has cracks that allow water to seep down rapidly, such as limestone) then groundwater contamination is more likely. Check with neighbors, well logs from your local health department, local farmers or well drilling companies to learn more about what's under your property.

## ✓ Assessment 1 – Risks Related to Well Location

Use the following assessment to rate your well location risks. For each question, put your risk level (low, medium or high) in the column labeled “Your risk.” Although some choices may not correspond exactly to your situation, choose the response that fits best. Refer to Part 1 above if you need more information to complete the table.

	<b>Low risk/ recommended</b>	<b>Medium risk/ potential hazard</b>	<b>High risk/ unsafe situation</b>	<b>Your risk</b>
<b>Position of well in relation to pollution sources</b>	Well is uphill (upgradient) from all pollution sources. Surface water doesn't reach well or is diverted.	Well level with or uphill from most pollutant sources. Some surface water runoff may reach well.	Well located downhill (downgradient) from pollution sources or in pit or depression. Surface water runoff reaches well.	
<b>Separation distances between private well and pollution sources</b>	Meets or exceeds all state minimum required distances: 10' - surface water 50' - septic tank, drainfield, animal yard, fuel storage 150' - pesticide/fertilizer storage or mixing	Meets minimum distance requirements for some but not all pollution sources.	Does not meet minimum separation distances for most or all potential sources (required to be at least 50 feet from well).	
<b>Soil type</b>	Fine-textured soils such as clay loams and silty clay.	Medium-textured soils, such as loam.	Coarse-textured soils such as sands, sandy loam or gravel.	
<b>Subsurface conditions</b>	Water table deeper than 30 feet.	Water table at 20 to 30 feet.	Water table or fractured bedrock shallower than 20 feet.	
<b>A boxed risk level</b> indicates level required for Residential Environmental Assurance Program certification.				

## Responding to risks

Your goal is to lower your risks. Turn to the Action Checklist at the end of the chapter to record the medium and high risks you identified. Use the recommendations above to help you plan actions to reduce your risks.

## Part 2 – Well Construction and Maintenance

Old or poorly designed wells increase the risk of groundwater contamination by allowing surface water to reach the water table without being filtered through soil. If a well is located in a depression or pit or if it is not properly sealed and capped, surface water carrying nitrates, bacteria, viruses, pesticides and other pollutants may flow directly into your drinking water.

You wouldn't let a car go too long without a tune-up or oil change. Your well deserves the same attention. Good maintenance means keeping the well area clean and accessible, keeping pollutants as far away as possible, and periodically having a qualified well driller or pump installer check the well when problems are suspected. Be sure to check periodically that the well cap and vent are intact and secure. At the end of Part 2, fill out the assessment to determine risks related to well design or condition.

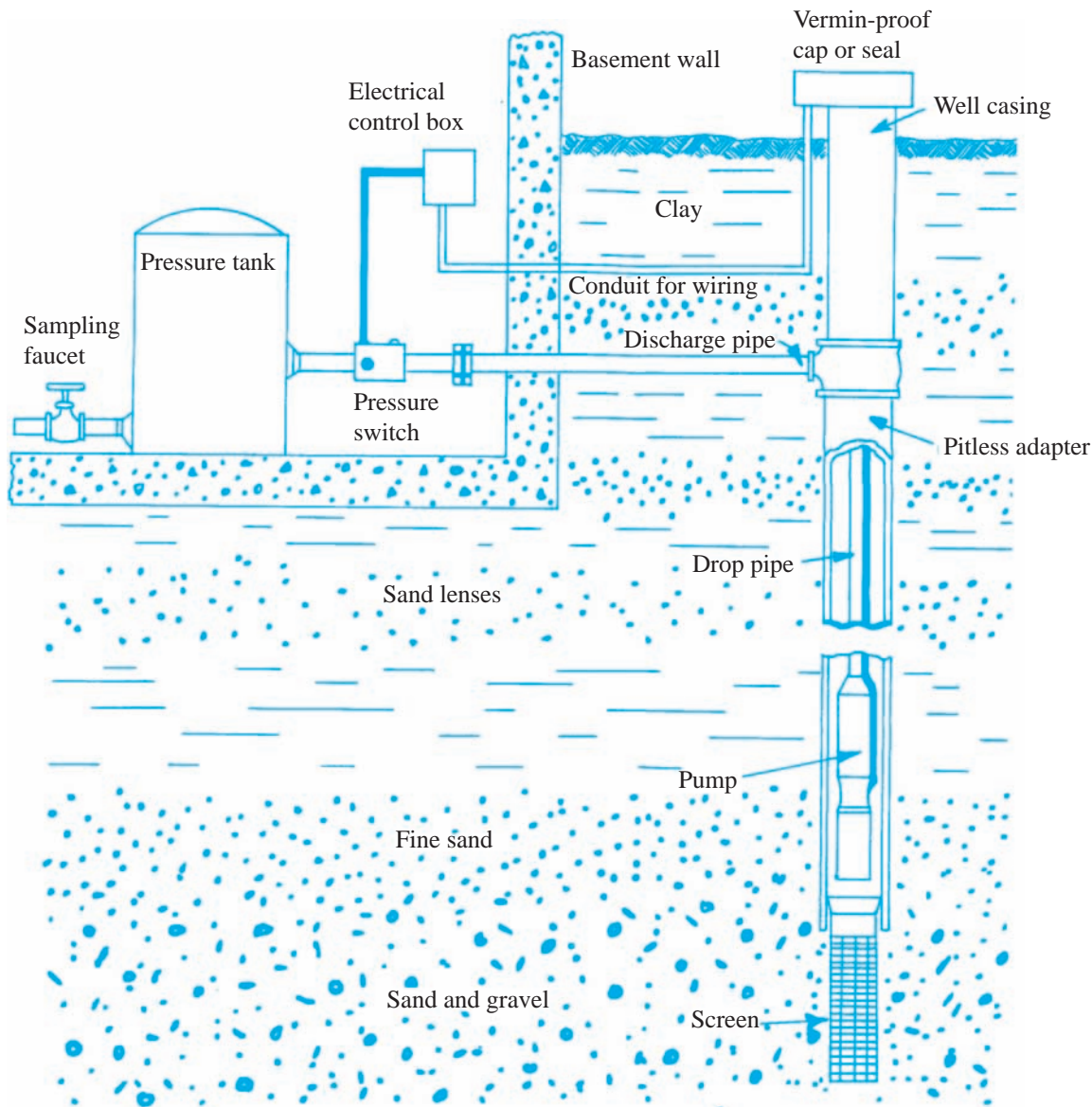

Adapted from "Planning Your Well: Guidelines for Safe, Dependable Drinking Water." University of Illinois-Champaign Cooperative Extension, 1998.



## How old is your well?

Well age is an important factor in predicting the likelihood of contamination. Wells constructed more than 70 years ago are likely to be shallow and poorly constructed. Older well pumps are more likely to leak lubricating oils, which can get into the water. Older wells are also more likely to have thinner casings, which may be cracked or corroded. Even wells with modern casings that are 30 to 40 years old are subject to corrosion and perforation. If you have an older well, you may want to have it inspected by a registered well driller.

## What type of well do you have?

A **dug well** is a large-diameter hole, usually more than 2 feet wide, and constructed by hand or with a large boring machine. Dug wells are usually shallow and poorly protected from surface water runoff. They pose a high public health and safety risk. **Driven-point (sand point) wells**, which pose a moderate to high risk, are constructed by driving lengths of pipe into the ground. These wells are normally around 2 inches in diameter and less than 50 feet deep and can be installed only in areas with loose soils such as sand. All other types of wells are **drilled wells** which, for residential use, are commonly 4 to 8 inches in diameter.

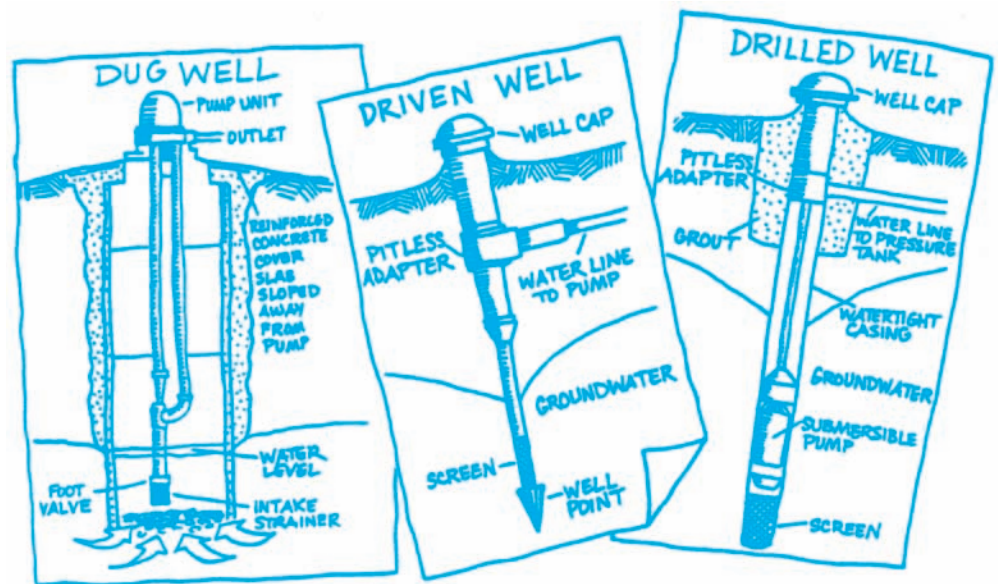

## Are your well casings and well cap protecting your water?

Well drillers install a steel or plastic pipe casing to prevent collapse of the hole after drilling. The space between the casing and the sides of the hole offers a direct channel for surface water—and pollutants—to reach the water table. To seal off this channel, drillers fill the space with **grout** (cement or a special type of clay called bentonite). Older drilled wells may not be grouted. If your water turns cloudy after a heavy rain or spring thaw, the space surrounding the well casing may have a defective grout seal. You should visually inspect your well casing for holes or cracks or space around the casing. Examine the part that extends from the ground. If you can move the casing around by pushing it, you may have a problem with your well casing's ability to keep out contaminants. Sometimes, damaged casings can be detected by listening for water running down into the well when the pump is not running. If you hear water, there might be a crack or hole in the casing, or your casing may not reach down to the water table. Either situation is risky.

The depth of casing required for your well depends on the depth to groundwater and the nature of the soils and bedrock below. A minimum of 25 feet of casing is required in Michigan for all wells. The well cap should be firmly attached to the casing, with a screened vent allowing only air to enter. Newer well caps provide protection from insects with a screened vent and gasket. They can quickly be identified by the presence of vertical screws. Older caps have no screen or gasket and have screws going horizontal to the well casing. The cap must be at least 1 foot above the soil surface. Wiring for the pump should be secured in an electric conduit pipe.

### Is your well shallow or deep?

As rain and surface water soak into the soil, they may carry pollutants down to the water table. In some places, this process happens quickly—in weeks, days or even hours. Local geologic conditions determine how long this takes. Shallow wells, which draw from groundwater nearest the land surface, are most likely to be affected by local sources of contamination. However, deep wells do not guarantee protection from contamination.

### Does your water piping system have backflow prevention?

**Backflow** of contaminated water into your water supply can occur from back pressure and/or back-siphonage. This can happen in a public or private water system. If the drinking water system is connected directly to another piping system or process (cross-connection) that operates at a higher system pressure, back pressure backflow can occur. Typical causes of back pressure backflow include: nonpotable piping systems equipped with pumping equipment such as irrigation well interconnected with a potable system, steam or hot water boilers, or exchange heaters. Anti-backflow devices should be installed on all faucets with hose connections. This reduces the risk of contaminated water reentering your plumbing from laundry, appliances, sinks, swimming pools, irrigation systems, hot tubs and garden hoses. Inexpensive devices for faucets with hose connections can be purchased from plumbing suppliers. Contact your local plumbing inspector for information on the proper back-siphoning device for your situation.

### When was your well last inspected?

Well equipment doesn't last forever. Every 10 to 20 years, your well will require mechanical attention from a registered well driller or pump installer. In addition to water test results, you should keep well construction details as well as the dates and results of maintenance visits for the well and pump. It is important to *keep good records* so you and future owners can follow a good maintenance schedule. Your water well record (well log) can be obtained from your local health department or from the company that drilled your well. If neither of these sources has your well record on file, you can obtain records from the online Michigan Department of Environmental Quality Scanned Water Well Record Retrieval System ([www.deq.state.mi.us/well-logs/](http://www.deq.state.mi.us/well-logs/)). This system contains water well records from 1965 through 1999. Some historic records for wells submitted prior to 1965 may also be available. Newer well records are accessible online at <http://wellviewer.rsgis.msu.edu/default.htm>.



## ✓ Assessment 2 – Risks Related to Well Type and Condition

Use the following assessment to rate risks related to well type, well casing and backflow. For each question, put your risk level (low, medium or high) in the column labeled “Your risk.” Although some choices may not correspond exactly to your situation, choose the response that fits best. Refer to Part 2 above if you need more information to complete the table.

	<b>Low risk/ recommended</b>	<b>Medium risk/ potential hazard</b>	<b>High risk/ unsafe situation</b>	<b>Your risk</b>
<b>Well age</b>	Less than 20 years old.	20 to 70 years old.	More than 70 years ago.	
<b>Well type</b>	Drilled well.	Driven-point (sand point).	Dug well.	
<b>Casing height above land surface</b>	At least 12 inches above the surface.	At surface or up to 8 inches above.	Casing below surface or in pit or basement.	
<b>Well casing and cap</b>	Grouted, drilled well. No holes or cracks. Cap tightly attached. Cap with gasket and screened vent (vertical screws present).	Driven, ungrouted well. No holes or cracks visible. Cap without gasket or screened vent (horizontal screws present).	Ungrouted drilled or dug well. Holes or cracks in casing visible. Cap loose or missing. Running water can be heard.	
<b>Casing depth</b>	Casing extends more than 100 feet below water table.	Casing extends 10 to 100 feet below water table.	Casing extends less than 10 feet below table.	
<b>Backflow prevention</b>	Anti-backflow devices installed on faucets with hose connections. No cross-connections between water supplies.	No anti-backflow devices. No cross-connections between water supplies.	No anti-backflow devices. Cross-connections between water supplies.	
<b>Well inspection and tune-up</b>	Well inspected within the past 10 years.	Well inspected 10 to 20 years ago.	Last well inspection unknown, or done over 20 years ago.	
<b>A boxed risk level</b> indicates level required for Residential Environmental Assurance Program certification.				

### Responding to risks

Your goal is to lower your risk. Turn to the Action Checklist at the end of the chapter to record the medium and high risks you identified. Use the recommendations in Part 2 to help you plan actions to reduce your risks.

## Part 3 – Water Testing and Unused Wells

Water testing helps you monitor water quality and identify potential risks to your health. Contaminants may enter drinking water from many sources. One important source is old, abandoned wells which, if improperly sealed, can provide a direct route for contaminants to enter groundwater. It is important to identify older or abandoned wells and take appropriate action. Although this part of the chapter focuses on local sources, contaminants can also come from sources outside your property boundaries. At the end of Part 3, fill out the assessment to determine water quality risks related to water contaminants and old wells.

### When was your water last tested?

At a minimum, your water should be tested each year for the two most common indicators of trouble: coliform bacteria and nitrates. If you haven't had a full-spectrum, comprehensive water test, then you don't know the basic characteristics of your water. A more complete water analysis for a private well will tell you about its hardness, alkalinity, conductivity, iron, nitrate, sodium and chloride content. In addition, you may choose to obtain a broad-scan test of your water quality for other contaminants, such as pesticides. A good source of information is your local health department or even your neighbors. Ask them what their tests have revealed.

### What contaminants should you look for?

You should test for the contaminants that might be found at your location. For example, if you have lead pipes, soldered copper joints or brass parts in the pump, test for the presence of lead. Test for volatile organic compounds (VOCs) if there has been nearby use or a spill of oil, liquid fuels or solvents.

Pesticide tests, though expensive, may be justified if your well has high nitrate levels—more than 10 milligrams per liter (mg/l) of nitrate-nitrogen ( $\text{NO}_3\text{-N}$ ) or 45 mg/l of nitrate ( $\text{NO}_3$ )—and if pesticides are used routinely in the immediate area. Test also if a pesticide spill has occurred near the well. Pesticides are more likely to be a problem if your well is shallow, has less than 15 feet of casing below the water table, or is located in sandy soil and is downslope from irrigated lands where pesticides are used.

In some areas of Michigan, there are certain concerns to be aware of that may be potential sources of drinking water contamination. Near Alpena, Rogers City, Monroe and parts of the Upper Peninsula in special geographic areas called karsts, the underlying bedrock is made up of carbonate rocks such as limestone (Figure 3). Over time, the rock may dissolve away, creating pathways for contaminants to reach drinking water sources. In other areas, naturally occurring arsenic can be found in groundwater. Southeastern Michigan is one such area (Figure 4).

In certain instances—for example, during an emergency when water supplies might have been contaminated with bacteria—local health departments may advise residents to boil water before drinking it. This is often called a boil water advisory. Boiling water is not advised if the water is contaminated with nitrates because boiling it will concentrate the nitrates, making it more harmful

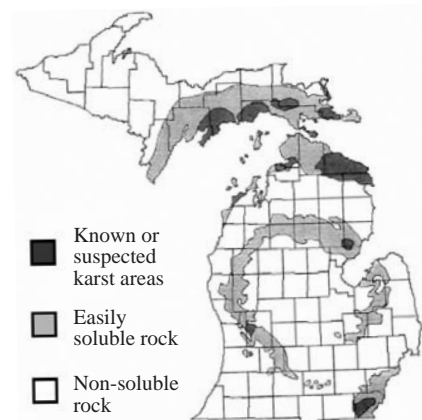

Figure 3: Bedrock areas of concern. “*Understanding Groundwater.*” *Institute of Water Research/Center for Remote Sensing, MSU.*

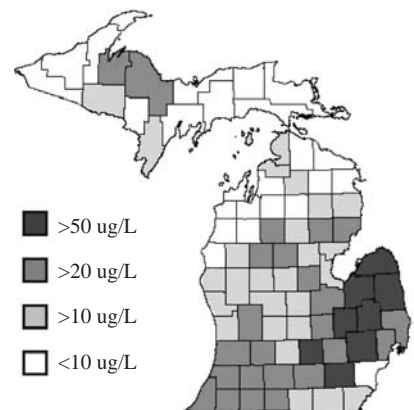

Figure 4: Michigan's groundwater arsenic levels by county. *Michigan Department of Environmental Quality.*

when consumed. This is a particular concern for pregnant women, infants, children or those who may be chronically ill. To be sure your water is safe, follow the guidelines by your local officials and your health department or visit [www.epa.gov/safewater/faq/emerg.html](http://www.epa.gov/safewater/faq/emerg.html) for more information about disinfection of drinking water. You can seek further advice on water testing from your county MSU Extension office or health department. You should test your water more than once a year if someone in the household is pregnant or nursing; unexplained illnesses occur in the family; your neighbors find a dangerous contaminant in their water; you note a change in water taste, odor, color or clarity; or you have a spill or backflow of chemicals or fuels into or near your well. Water can be tested by either public or private laboratories certified by the Department of Environmental Quality. Keep records of your results to monitor water quality over time.

### Are there any unused or abandoned wells on your property?

Many properties have wells that are no longer used. Sites with older homes often have an abandoned shallow well that was installed when the house was built. If not properly filled and sealed, these wells can provide waterborne pollutants a direct channel to groundwater. Contact your local health department’s environmental health division for information on closing abandoned wells and the form for recording the closure. A registered well driller may be hired to close these wells. Effective well plugging calls for experience with well construction materials and methods, as well as knowledge of the geology of the site. Costs will vary with well depth, diameter, difficulty in removing well parts in the casing and soil/rock type. The money spent sealing a well will be a bargain compared with the potential costs of cleanup or the loss of property value if contamination occurs.

## ✓ Assessment 3 – Water Testing and Abandoned Wells

Use the following assessment to rate risks related to well type, well casing and backflow. For each question, put your risk level (low, medium or high) in the column labeled “Your risk.” Although some choices may not correspond exactly to your situation, choose the response that fits best. Refer to Part 3 above if you need more information to complete the table.

	Low risk/ recommended	Medium risk/ potential hazard	High risk/ unsafe situation	Your risk
<b>Water testing</b>	Water test consistently meets standards for bacteria, nitrate and other contaminants. No change in color, odor, taste or clarity.	Some tests do not meet standards.	No water testing done or results unsatisfactory in meeting standards. Water discolored after rainstorm or during spring melt. Noticeable changes in color, odor and taste.	
<b>Unused wells</b>	No unused wells present or they have been properly sealed.	Unused wells not sealed but capped and isolated from contaminants.	Unused, unsealed well in poor condition and/or near pollution sources, or uncapped.	
<b>A boxed risk level</b> indicates level required for Residential Environmental Assurance Program certification.				

### Responding to risks

Your goal is to lower your risk. Turn to the Action Checklist on the next page to record the medium and high risks you identified. Use the recommendations above to help you plan actions to reduce your risks.

## ✓ Action Checklist

When you finish the assessment tables, go back over the questions and list below every high and medium risk you identified. For each of these risks, write down the improvements you plan to make. Use recommendations from this chapter and from other resources. Pick a target date to keep you on schedule for making the changes. You don't have to do everything at once, but try to eliminate the most serious risks as soon as you can. Often it helps to start with inexpensive actions first.

Write all high and medium risks here.	What can you do to reduce the risk?	Target date for action:
Example: Water hasn't been tested for 10 years. Smells different than it used to.	Have sample tested. Contact local health department for laboratory test bottles.	One week from today: June 15

### Resources

#### Drinking water quality standards:

Michigan Department of Environmental Quality Drinking Water Bureau  
517-355-8184; [www.michigan.gov/deq](http://www.michigan.gov/deq)

U.S. Environmental Protection Agency Safe Drinking Water Hotline  
1-800-426-4791 (toll-free); [www.epa.gov/safewater](http://www.epa.gov/safewater)

National Drinking Water Clearinghouse  
[www.nesc.wvu.edu/ndwc/ndwc\\_index.htm](http://www.nesc.wvu.edu/ndwc/ndwc_index.htm)

U.S. Geological Survey Michigan Water Science Center  
<http://mi.water.usgs.gov>

**Drilling and sealing wells:** Contact your local well driller, county health department or the Michigan Department of Environmental Quality Water Bureau (517-241-1413).

Plugging Abandoned Wells. MSU Extension bulletin WQ40.

**Groundwater, geology and locating wells:** Contact the Michigan Department of Environmental Quality, Office of Geological Survey (517-241-1515), your local conservation district, the county health department or the Groundwater Mapping website ([gwmap.rsgis.msu.edu](http://gwmap.rsgis.msu.edu)). You can also check this website or with the health department to obtain well logs.

**Well water testing:** Contact the environmental health division of your local health department, your county MSU Extension office or certified private testing laboratories.

This chapter was written by Bill McGowan, Agriculture/Water Quality Extension, University of Delaware Cooperative Extension, and adapted for Michigan by Lois Wolfson, Ruth Kline-Robach, Ted Loudon, Roberta Dow and Jim Bardenhagen, Michigan State University Extension. Updated in 2008.





**T**his chapter helps you evaluate your septic system and pinpoint risks before they become problems. It provides general guidelines for safe management of household wastewater. Local laws, however, may impose more stringent or additional requirements. For example, some systems—such as cesspools—may be banned locally. Contact your local health department, MSU Extension office or environmental agencies, or a septic system contractor for advice.

**This chapter covers three factors that affect your pollution risks:**

- ◆ **1. Design and location**  
Knowing your septic tank capacity, soil type in the drainfield and your system’s location.
- ◆ **2. Maintenance**  
Pumping the septic tank, protecting the drainfield, watching for signs of trouble.
- ◆ **3. Inputs to the system**  
Reducing the amounts of water, solids and harmful chemicals going into your system.



## Chapter 11. Managing Household Wastewater: Septic Systems and Other Treatment Methods

### Why should you be concerned?

Wastewater treatment systems help protect your health and the environment. Household wastewater from sinks, toilets, washing machines and showers—carrying dirt, soap, food, grease, bodily wastes and pathogens—flows down the drain and out of your house. Disease-causing microbes (pathogens), hazardous chemicals and nutrients such as phosphorus, nitrates and organic wastes found in wastewater can lead to human illness and polluted water. Wastewater must be treated before these contaminants reach groundwater—the source of well water—or nearby lakes, streams or wetlands.

Wastewater treatment is often out of sight and out of mind until problems occur. Learn the basics about your household system and take simple precautions to prevent problems. It’s a wise investment to keep your system properly working. Replacing a failed system can cost thousands of dollars. Untreated or poorly treated wastewater can contaminate your drinking water or pollute water resources needed for wildlife, agriculture, industry and recreation.

If you live on or near a lake or stream and would like more information about the special role you play in preventing contamination of your lake or stream by household wastewater, please refer to MSU Extension bulletin WQ-52, “Managing Shoreline Property to Protect Water Quality.”

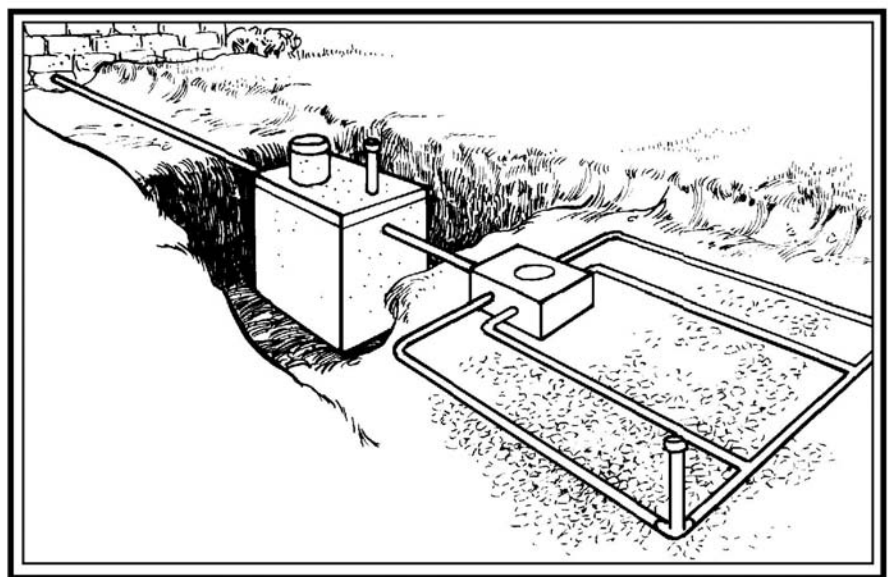

Figure 1: Septic tank with soil absorption field (drainfield or leachfield).

## Are you hooked up to a city or community sewer system?

Even if wastewater is not treated on your property, you can still lessen the impact that your wastewater has on your community and the environment. Conserving water and being careful about what you put into your sinks and toilets are ways you can help. Call your local sewage treatment authority for more information. Using your system wisely saves taxpayers' dollars and protects our water resources.

## Do you have a septic system or other on-site system to treat wastewater?

This chapter is geared toward homeowners or tenants who have septic systems buried in their yards. A typical septic system consists of a septic tank followed by an absorption field, also known as a drainfield or leachfield (Figures 1 and 2). The chapter sections on system maintenance and reducing inputs will also apply to those households with holding tanks or septic tanks followed by a mound, sand-filter or other alternative on-site treatment system.

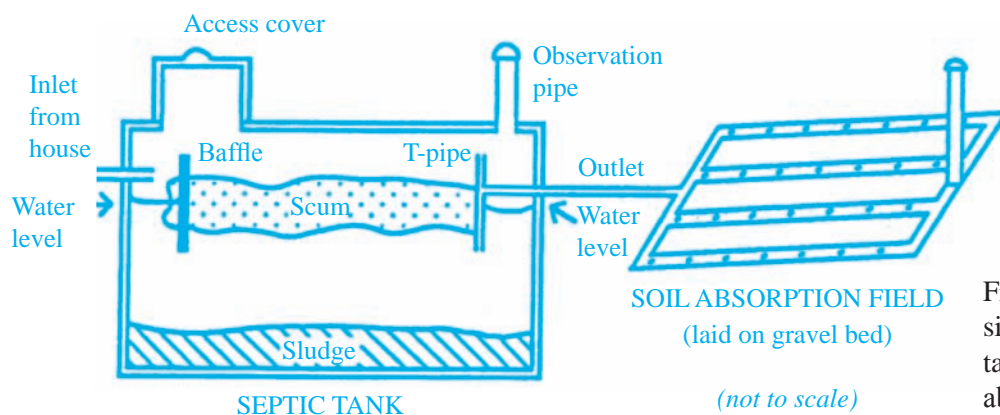

Figure 2: Cross-section of single-chambered septic tank and drawing of soil absorption field (drainfield).

## How does a conventional on-site septic system work?

Wastewater flows through a sewer pipe out of your house and into the **septic tank**, a watertight box or cylinder commonly made out of concrete or a plastic material (Figure 2). Today, double-chambered septic tanks are increasingly more common because they provide better retention of sludge, thus protecting the drainfield. Lighter solids such as grease, hair and soap float to the top of the tank, forming a **scum layer**. Heavier solids settle to the bottom, forming a layer of **sludge**. A baffle near the tank inlet slows the incoming rush of water so that the sludge is not stirred. A baffle or T-pipe located at the tank's outlet keeps the solids from leaving the tank and entering the absorption field. Bacteria in the tank break down some of the sludge into simple nutrients, gas and water. The remaining solids are stored in the tank until they're pumped out.

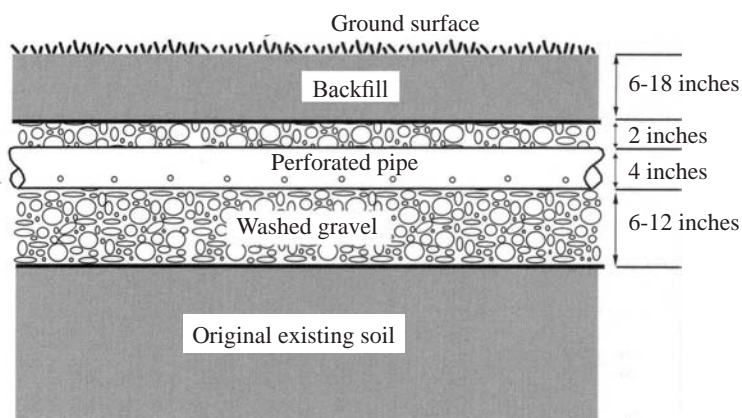
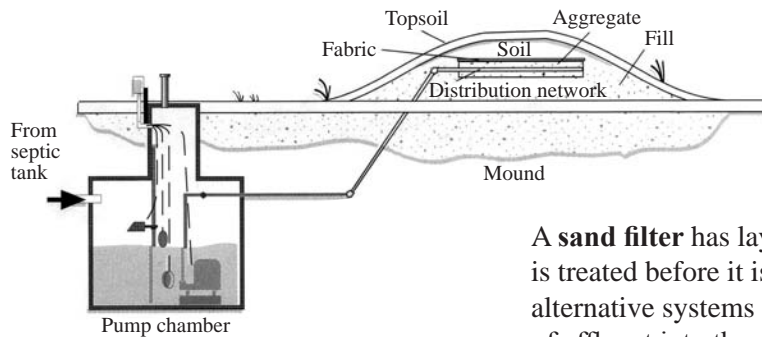

Figure 3: Cross-section of portion of drainfield.



The liquid waste, called **effluent**, flows out of the tank and into the **soil absorption field (drainfield)** (Figure 3). The soil absorption field is usually perforated plastic pipe laid in gravel-filled trenches in the ground. Effluent is fed into pipes by gravity or mechanically pumped to improve distribution. As the effluent percolates (moves slowly) downward from the pipes, additional particles and pathogens are filtered out by the soil. Bacteria and natural chemical processes break down or remove contaminants in the effluent. The soil must be a suitable type and deep enough to treat the wastewater before it reaches groundwater. To prevent contamination of water supplies, the drainfield must also be set back (isolated) from any water well, wetland, shoreline or stream.

Soils vary in their ability to treat wastewater. Well-drained, medium-textured soils such as loam are best. Coarse gravel or sandy soils allow wastewater to flow too quickly for treatment. In fine clay or compacted soils, water moves too slowly. Beneficial soil microbes need oxygen to break down wastes quickly. If the soil is saturated with water, it becomes anaerobic (lacking oxygen). Under anaerobic conditions, bacteria digest waste slowly, unpleasant odors are released, and the septic system can fail.



Mound system at grade

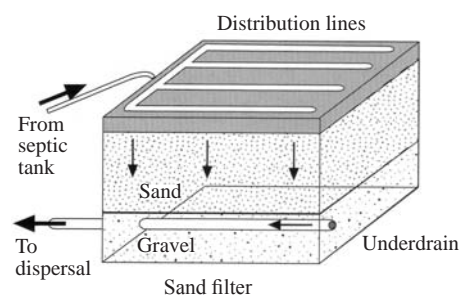

Sand filtration system

### What are some alternative systems?

If soil or site conditions are not suitable for a conventional drainfield, an alternative system might be used (Figure 4). In a **mound system**, the drainfield is elevated to provide additional soil depth for treatment.

A **sand filter** has layers of sand and gravel in which the wastewater is treated before it is distributed into the existing soil. These alternative systems may require a pump or siphon to send even doses of effluent into the distribution system. **Aerobic treatment units** mix wastewater with air on surfaces where bacteria can feed on the organic wastes and pathogens. Aerobic tanks are used in place of septic tanks, most often at sites that do not have adequate soil area or depth for effective subsurface wastewater treatment. Holding tanks may be used in temporary situations prior to a new system hookup or at summer residences. In contrast to a septic tank, a holding tank has no outlet and must be pumped frequently to dispose of wastewater.

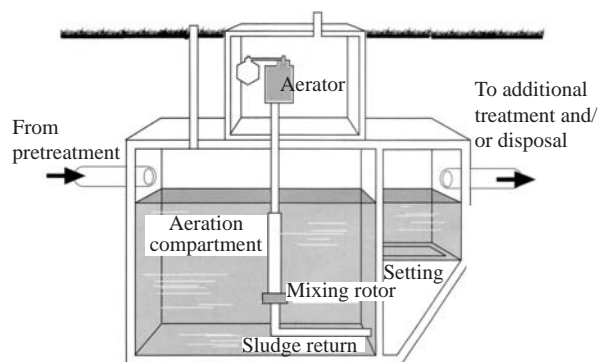

Aerobic treatment unit

Figure 4: Some alternative treatment systems. Graphics developed by and reprinted with permission from the National Environmental Services Center, West Virginia University, Morgantown, W. Va.; [www.nsfv.wvu.edu](http://www.nsfv.wvu.edu).

# Part 1 – Septic System Design and Location

## Capacity of system

The septic tank and drainfield should have adequate capacity to treat all the wastewater generated in your house, even at times of peak use, such as when the house is occupied by a large family. The amount of wastewater flowing out of the house is an estimated 150 gallons of wastewater per bedroom per day multiplied by the number of bedrooms in the house. The estimated flow rate is lower if low-flow toilets and water-saving faucets are installed.

The septic tank capacity should be large enough to hold two days' worth of wastewater—long enough to allow solids to settle out by gravity. A two-compartment tank or two tanks in series can improve sludge and scum removal and help prevent drainfield clogging. A new three-bedroom house in some areas may be equipped at a minimum with a 1,000-gallon septic tank. More commonly, however, health departments are requiring at least 1,200- or 1,500-gallon tanks. Complete the following exercise to determine whether your septic tank is large enough to adequately process the wastewater generated by the members of your household.

The required size of the drainfield is based both on how much wastewater will be put into the system and how much water the soil can take up. The design of the drainfield depends on your soil type, which will determine the length of the drainfield trenches.

The septic system is stressed when the amount of household wastewater exceeds the system's capacity. For example, additions of water-using appliances such as a garbage disposal, washing machine or dishwasher can greatly increase the wastewater load to your system. Also, if your home was originally built to be a seasonal residence such as a summer cottage but you have converted the home to a full-time residence, the original septic system may no longer be able to handle the increased wastewater being generated. In all cases, conserving water, more frequent pumping and updating your septic system so that it can efficiently and safely process your wastewater may be required.

### Is your septic tank capacity adequate?

The amount of wastewater generated by the average individual ranges from 50 to 100 gallons per day. Use the following equation to estimate the wastewater generated by your household. Your septic tank capacity should be large enough to hold two days' worth of wastewater.

$$\text{___ Number of individuals in household} \times 75 \text{ gallons per day} \times 2 \text{ days} \\ = \text{___ gallons wastewater generated by your home in 2 days.}$$

\_\_\_ Septic tank capacity (contact health department if you don't have records).

Which is greater?

\_\_\_ 2-day amount                      \_\_\_ Septic tank capacity

If your 2-day wastewater amount is larger than your septic tank capacity, you need to reduce your wastewater or upgrade your system.



If you do not know the capacity of your system, ask the septic tank installer or pumper, or contact the local health department or the previous owner of your home to obtain information about the septic system.

### Age of system

Septic systems are expected to last anywhere from 15 to 40 years, depending on how well they are maintained and if they are appropriately designed for the site. If your tank is made of steel, it will rust and need replacement. The older your system, the more likely that it does not meet the latest standards. Even a relatively new system can fail, however, if it is undersized or not properly located and maintained.

### Does your system need safety devices?

A holding tank or pumping chamber should have an alarm to warn you when it is full. This prevents hazardous overflows. Backup power supplies should be available on systems with pumps or other electrical components.

### Separation distances

The septic tank and drainfield should be at least 50 feet from your drinking water well and your neighbor's well. The greater the distance, the lower the chance of contaminating the water supply. If your system is downhill (downgradient) from the well, you will be better protected. You should test your well water more often if you find that your system is closer to your well than recommended. For more information on testing or to find certified laboratories, contact your local health department, your local MSU Extension office or the Department of Environmental Quality (DEQ) Environmental Science and Service Division (see "Resources" at the end of this chapter).

### Do you know exactly where your system is located?

To take proper care of a septic system, you must know where it is located. The exact locations of septic system components are not obvious because they are belowground. If the information is not in your home records, your county health department's records may give the answer. You may be able to locate your septic tank by finding where the sewage pipe leaves the basement of your house and noting the direction in which it goes through the wall. Your tank is usually 10 to 20 feet away from the house in that direction.

Draw a map of your system.  
*National Environmental  
Services Center.*

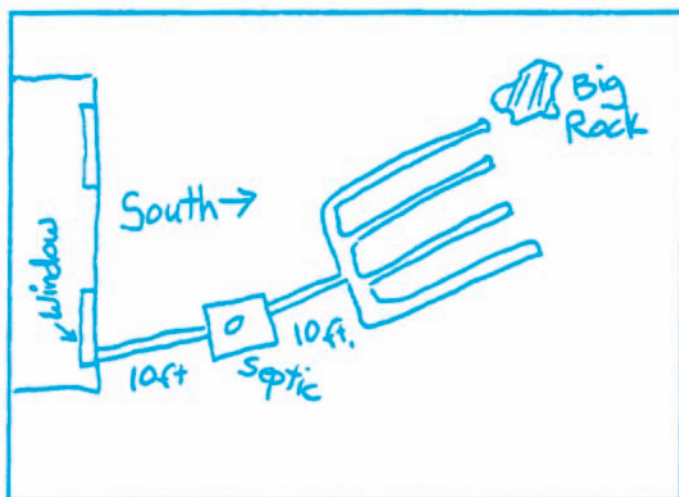

## ✓ Assessment 1 – Risks Related to Septic System Design and Location

Use the following assessment to begin rating your pollution risks. For each question, put your risk level (low, medium or high) in the column labeled “Your risk.” Choose the response that best fits your situation.

	<b>Low risk/ recommended</b>	<b>Medium risk/ potential hazard</b>	<b>High risk/ unsafe situation</b>	<b>Your risk</b>
<b>Capacity of system</b>	Tank and drainfield designed to handle more wastewater than required for the number of residents.	Capacity just meets wastewater requirements.	Current flow of wastewater greater than current capacity of system.	
<b>Age of system (includes holding tanks)</b>	Less than 5 years old.	Between 6 and 20 years old.	System more than 20 years old.	
<b>Safety devices</b>	Alarm on holding tank or pumping tank chamber for overflow or power cutoff.		No alarm to indicate chamber overflow or power cutoff on electrical pumps.	
<b>Separation distances</b>	Septic tank and drainfield at least 50 feet from all wells.		Tank and drainfield less than 50 feet from all wells.	
<b>A boxed risk level</b> indicates level required for Residential Environmental Assurance Program certification.				

### Responding to risks

Your goal is to lower the risks. Use the Action Checklist at the end of the chapter to record the medium and high risks you identified. Use recommendations in this chapter to help you make plans to reduce your risks.

## Part 2 – Septic System Maintenance

### What about pumping and inspection?

Regular pumping is the most important action you can take to maintain your system. The tank should be pumped by a licensed pumper about every three to five years. A septic haulers directory is available at [www.deq.state.mi.us/shr](http://www.deq.state.mi.us/shr). Use Table 2 to help you estimate how often your tank should be pumped. The tank should also be inspected for cracks and the condition of the baffles. Never crawl inside or lean into the tank—the gases inside the tank can be deadly.

A septic tank operates best when it is no more than one-third full of sludge and scum. As more solids accumulate in the tank, particles are more likely to flow out of the tank and into the drainfield, where premature clogging may occur. The costs of pumping a septic tank (\$100 to \$350) are far less than the expense of replacing a drainfield clogged by escaping solids (\$3,000 to \$6,000).

By design, holding tanks must be pumped because they have no outlet. Depending on the amount of wastewater generated and tank capacity, you may need to pump every month or every week. If you assume that every person in the house uses 25 gallons of water a day, four people can fill a 1,500-gallon tank in 15 days. Overflows are a sure sign that you need to schedule pumping more often.

**Do you know when your tank was last pumped?**

Keeping good records each time your septic system is pumped, inspected or repaired will help you make cost-effective maintenance decisions (Table 1). This information will also be valuable if you sell or transfer your property.

**Table 1. Keep a septic system maintenance record.**

Date	Work done	Performed by

**Table 2. Years between pumpings.**

Find your tank’s size (in gallons) along the left side of the table. Go across the row to the column for the number of people in your home. Where the row and column intersect, you’ll find the estimated number of *years between pumpings*. Example: if you have two people in your household and a 1,000-gallon tank, with average use and no garbage disposal, you would need to pump the tank approximately every 5.5 years.

Tank size (gallons)	Number of people in your household					
	1	2	3	4	5	6
500	5.5	2.5	1.5	1	.5	.5
1000	12	5.5	3.5	2.5	2	1.5
1500	18.5	9	5.5	4	3	2.5
2000	25	12	8	5.5	4.5	3.5



## How can you protect your drainfield?

- ◆ Do not drive vehicles on the drainfield to prevent soil compaction and damage to pipes.
- ◆ Do not pave, build, pile logs or set a swimming pool over the drainfield. Soil microbes need oxygen to digest wastes.
- ◆ Divert water softener discharge, roof runoff, footer drains, sump pumps and other surface runoff away from the drainfield. Don't pile snow on the drainfield. Saturated soil is less effective at treating wastewater.
- ◆ Avoid trees and shrubs whose deep roots can damage piping. Grass is the best cover.
- ◆ Install an effluent filter on the septic tank outlet to prevent carryover of solids into the drainfield.
- ◆ Avoid draining a hot tub or swimming pool into the septic system or over the drainfield.

## What are the signs of trouble?

- ◆ Foul odors in your home or yard tell you that your system is not working well.
- ◆ Slow or backed-up drains may be caused by a clog in the house pipes, septic tank, drainfield or roof vent for your septic system.
- ◆ Wet, spongy ground or lush plant growth may appear near a leaky septic tank or failing drainfield.
- ◆ Repeated intestinal illness in your family may occur if your water is contaminated by poorly treated wastewater. Have your drinking water tested annually for coliform bacteria and nitrates. (See Chapter 10.)
- ◆ Algal blooms and excessive weed growth in nearby ponds or lakes can be caused by excess phosphorus or nitrogen from septic systems.

Respond quickly to any problems you observe. You may need to expand or modify your system to avoid further problems. Contact your local health department before making changes. Many good publications and other resources are available to help you (see “Resources” and “Publications” at the end of this chapter). Call local contractors or visit an MSU Extension office to get recommendations. Try to base your decision on what is best for the environment and your health. Remember, what may seem to be the least expensive option may not be economical in the long run.

### How should I dispose of the discharge from my water softening system?

Check with your local health department to identify which of the following is the best option for your site:

- Dispose of water softener discharge via a subsurface perforated pipe in a stone trench.
- Direct the discharge on the surface of the ground away from the septic system.  
Note: this method may result in vegetation being killed from the salinity of the liquid.
- Connect the discharge to a dry well that is separate from the septic system.

## ✓ Assessment 2 – Risks Related to Septic System Maintenance

Use the following assessment to rate your septic system maintenance risks. For each question, put your risk level (low, medium or high) in the column labeled “Your risk.” Choose the response that best fits your situation. Refer to Part 2 if you need more information to complete the table.

	<b>Low risk/ recommended</b>	<b>Medium risk/ potential risk</b>	<b>High risk/ unsafe situation</b>	<b>Your risk</b>
<b>Tank pumping and inspection (includes holding tanks)</b>	Septic tank pumped and visually inspected on a regular basis—every 3 to 5 years (or as needed), and holding tanks pumped as needed.	Septic tank pumped but not regularly. Holding tank occasionally overflows or leaks between pumpings.	Septic tank not pumped. Holding tank regularly overflows or leaks between pumpings.	
<b>Drainfield protection</b>	Vehicles and other heavy objects or activities kept away from drainfield area. No deep-rooted plants, pavement or structures over the drainfield.		Vehicles, livestock, heavy objects or other disturbances permitted in area.	
<b>Signs of trouble</b>	Household drains flow normally. No sewage odors inside or outside. Soil over drainfield firm and dry. Well water tests negative for coliform bacteria.	Household drains run slowly or soil over drainfield is sometimes wet.	Sewage odors noticed in the house or near the drainfield. Drains plugged or back up. Soil wet or spongy in drainfield area. Well water tests positive for coliform bacteria.	
<b>Map and records</b>	Good map with house well and septic tank location and distances, plus records of system repairs and maintenance are kept.	No map or incomplete records.	No map or maintenance records kept.	
<b>A boxed risk level</b> indicates level required for Residential Environmental Assurance Program certification.				

### Responding to risks

As always, your goal is to lower your risks. Use the Action Checklist at the end of the chapter to record the medium and high risks you identified. Use recommendations in this section to help you make plans to reduce your risks.

## Part 3 – Septic System Inputs

### What solid wastes are acceptable?

Your septic system is not a substitute for the trash can or a compost pile. Dispose of tissues, diapers, sanitary napkins, cigarette butts and other solid waste with regular garbage and *not* down the toilet. These materials do not break down in your system, so they make your tank fill up faster. Avoid using a garbage disposal in the kitchen sink—it adds to the load in your system. Excess grease, oils and coffee grounds can clog your system. Consider composting food waste and even some paper wastes as an alternative.

### What household chemicals can go down the drain?

Wastewater treatment systems are not designed to neutralize the wide variety of household chemicals used. Paints, solvents, oils and pesticides can pass untreated through your system. See the product disposal assessment in Chapter 3, “Managing Hazardous Household Products,” for information on proper disposal of hazardous chemicals.

Septic system additives are unnecessary. If a septic system is functioning properly, the optimal bacterial action is already taking place. If a septic system is failing, additives will not correct a failing system.

### Why save water?

For septic systems, reducing water volume improves treatment effectiveness and system operation. Less water flowing through the tank means more time for solids to settle out and less chance of solid particles getting carried over to the drainfield. Less water in the drainfield means better aeration for the soil microbes at work in the system. There are many steps you can take to reduce water use. See Chapter 8, “Conserving Water around Your Home.”

## ✓ Assessment 3 – Risks Related to Septic System Inputs

Use the following assessment to rate your septic system maintenance risks. For each question, put your risk level (low, medium or high) in the column labeled “Your risk.” Choose the response that best fits your situation. Refer to Part 3 if you need more information to complete this assessment.

### Responding to risks

As always, your goal is to lower your risks. Use the Action Checklist on the following page to record the medium and high risks you identified. Use recommendations in this section to help you make plans to reduce your risks.





	<b>Low risk/ recommended</b>	<b>Medium risk/ potential risk</b>	<b>High risk/ unsafe situation</b>	<b>Your risk</b>
<b>Solid wastes</b>	No garbage disposal in the kitchen. No grease, oils or coffee grounds down the drain. Only toilet tissue in toilet.	Moderate use of garbage grinder and use of sink for disposal of some solids.	Heavy use of garbage grinder and disposal of many solids. Many paper products flushed down the toilet.	
<b>Cleaners, solvents and other chemicals (also applies to holding tanks)</b>	Moderate use of cleaning products that end up in wastewater. Hazardous chemicals never poured down drain or toilet.	Moderate use of cleaning products that end up in wastewater. Small amounts of hazardous chemicals poured down drain or toilet.	Heavy use of cleaning products that end up in wastewater. Wastewater used to dispose of hazardous chemicals.	
<b>Water Conservation</b>	Water-conserving fixtures and practices used. Drips and leaks fixed immediately.	Some water-conserving steps taken (low-flow shower heads, fully loaded washing machine or dishwasher).	No water-conserving practices. High-volume standard bathroom fixtures used (toilets, showers). Leaks not repaired.	
<b>A boxed risk level</b> indicates level required for Residential Environmental Assurance Program certification.				

## ✓ Action Checklist

Go back over the assessments and look for the high and medium risks you identified. Record them below. For each of your medium and high risks, write down the improvements you plan to make. Use recommendations from this chapter and other resources to decide on actions you are likely to complete. A target date will keep you on schedule. You don't have to do everything at once, but try to eliminate the most serious risks as soon as you can. Often it helps to tackle the inexpensive actions first.

<b>Write all high and medium risks here.</b>	<b>What can you do to reduce the risk?</b>	<b>Target date for action:</b>
Example: Area over drainfield is always wet.	Have drainfield inspected for blockages and cleaned as needed. Divert surface runoff.	One week from today: May 15

## Resources

**Drilling and sealing wells:** Contact your county or regional health department or local well drillers, or the Michigan Department of Environmental Quality at 517-241-1413.

**Drinking water quality standards.** Call the Michigan DEQ, 517-355-8184, or the U.S. Environmental Protection Agency Safe Drinking Water Hotline toll-free, 1-800-426-4791.

**Groundwater and geology:** Contact the U.S. Geological Survey, 517-887-8903; the Department of Environmental Quality Geological Survey, 517-241-1515; the local conservation district or your county health department.

**Septage handlers:** For a directory, go to [www.deq.state.mi.us/shr](http://www.deq.state.mi.us/shr).

**Septic system installers and pumpers:** For a listing by state of professional pumpers, installers, inspectors and tank manufacturers in the United States, including septic system information: [www.septicyellowpages.com](http://www.septicyellowpages.com)

**Water testing:** Contact your county or regional health department, your county Michigan State University Extension office or the DEQ Environmental Science and Service Division at 517-335-8812, or find DEQ-certified private testing laboratories at [www.deq.state.mi.us/labs](http://www.deq.state.mi.us/labs).

## Publications

**“Managing Your Septic System.”** MSU Extension bulletin WQ39

**“Managing Shoreline Property to Protect Water Quality.”** MSU Extension Bulletin WQ-52

Contact your local MSU Extension office or order online through the Educational Materials Distribution Center:

[www.emdc.msue.msu.edu](http://www.emdc.msue.msu.edu)

National Small Flows Clearinghouse:

[www.nesc.wvu.edu/nsfc](http://www.nesc.wvu.edu/nsfc)

U.S. Environmental Protection Agency Septic (Onsite) Systems:

[www.epa.gov/owm/septic](http://www.epa.gov/owm/septic)

Click on “Tools and Resources,” then “Homeowner.”

**“A Homeowner’s Guide to Septic Systems.”** EPA-832-B-02-005.

U.S. EPA Publications Clearinghouse: 1-800-490-9198.

This Home\*A\*Syst chapter does not cover all potential risks related to wastewater that could affect health or environmental quality. Other assessments on a variety of topics are available from your local MSU Extension office to help homeowners examine and address their most important environmental concerns.

This chapter was written by Barbara Kneen, Cornell University Extension, and adapted for Michigan by Eckhart Dersch, Ted Loudon, Roberta Dow and Jim Bardenhagen, Michigan State University Extension. Updated in 2008.





This chapter helps you identify potential risks to the environment and to your family’s health related to the way fuels are stored and managed. This assessment is divided into two parts:

### 1. Portable fuel containers

Fuel stored in portable containers and in the gas tanks of gas-powered machines is a potential risk to groundwater and surface water. If you own any of the following, this part of the chapter applies to you:

- ◆ Lawnmower
- ◆ Snowblower
- ◆ Snowmobile
- ◆ Chainsaw
- ◆ Motorcycle
- ◆ Campstove
- ◆ Weed trimmer
- ◆ Yard blower
- ◆ Motorboat
- ◆ Space heater
- ◆ Auxiliary generator

### 2. Large fuel tanks

This section is for homeowners with aboveground, basement or underground fuel tanks in use or inactive on their property. It examines:

- ◆ Tank location
- ◆ Tank management
- ◆ Removal and abandonment

It applies to non-business tanks that hold less than 1,100 gallons. Larger tanks or those used for business purposes (non-farm) are subject to greater regulation. This chapter does not cover the storage of liquefied gases such as liquid propane (LP) and liquid natural gas.



Michigan  
Groundwater  
Stewardship  
Program

## Chapter 12. Managing Liquid Fuels Safely: Gasoline, Heating Oil, Diesel and Other Fuels

### Why should you be concerned?

The proper storage of gasoline, heating oil and other fuels on your property is often overlooked. If you are like most people, you own at least one fuel-burning device such as a lawnmower and probably keep fuel in portable containers holding 1 to 5 gallons. For home heating and vehicle use, you also may have larger quantities of fuel kept in underground, basement or above-ground storage tanks.

Fuels are hazardous materials. Improperly managed, they can pollute the water you drink and the air you breathe. It is critical to prevent repeated spills and leaks. As little as 1 gallon of gasoline can quickly contaminate groundwater above health advisory levels. Petroleum products contain many toxic compounds, including benzene, which is known to cause cancer. You cannot depend on taste or smell to alert you to fuel in your drinking water. Leaks can come from unexpected sources. Unknown or forgotten underground tanks have come to haunt property owners.

Contaminated soil and water can reduce your property value, trigger environmental liability and costly cleanups, and drive away lenders and potential buyers. Vapors from fuel can ignite and start fires or collect underground and explode.

Fuel stored in large tanks poses a greater risk of contamination than the small quantities stored for power equipment. Though you should pay particular attention to high potential risks from large tanks, you should recognize that fuel stored in any amount increases the environmental risks around your home.

This chapter can help you evaluate how you manage liquid fuels, identify areas of risk (Figure 1), and develop an action plan to reduce or eliminate potential problems. Improving fuel storage and management has many payoffs. It protects the health of your family, your community and the environment. Better management also can safeguard your biggest investment—your home.

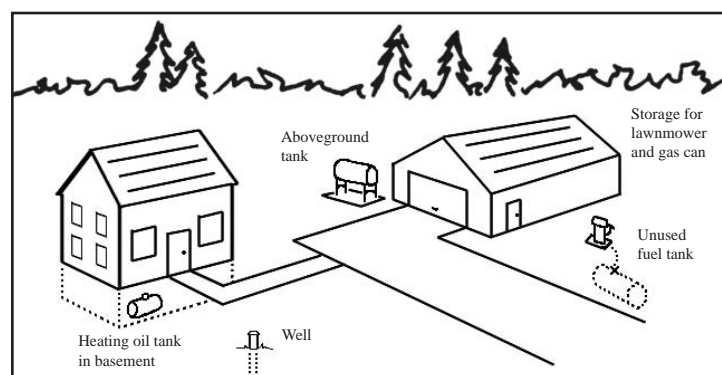

Figure 1: Areas of fuel contamination risk at the homesite.

## ✓ Part 1 – Portable Fuel Containers for Handling Small Quantities of Fuel

### How much fuel do you buy and use?

It is best to purchase and store minimal amounts of fuel for short periods. This means buying in small quantities and not buying more than you need for use in a season (6 months or so) of lawn mowing or snow blowing. Do you have more than a gallon of leftover fuel at the end of a season? Next time buy smaller quantities. If there are leftovers, try to use them up. Excess gasoline can be poured into a car's gas tank, for example, or given to someone who can use it. Dilute one part old fuel with five parts new fuel to protect your engine. Beware of oil-blended fuels, which should be used only in engines designed for these fuels. Extra gas left in equipment at the end of a season should be drained and used elsewhere. Fuel stabilizers may extend the shelf life of fuels.

### UL-approved containers

Fuel	Container color
Gas	Red
Kerosene	Blue
Diesel	Yellow

### Do you store fuels in approved containers?

It is important to use only safe, approved containers to store fuels. UL-approved containers (red for gasoline, blue for kerosene and yellow for diesel) can be purchased in places as convenient as your local hardware store. Each container should be clearly labeled to identify its contents and fitted with a spout or other device to allow pouring without spilling. Storing fuels in uncovered or non-approved containers is dangerous. For an extra measure of spill protection, fuel containers can be kept inside a tub or other container that would prevent leaks from spreading (secondary containment).



**Do not use glass jars, milk jugs or other non-approved containers.**

### Are containers kept in a well-ventilated, safe place?

To avoid fuel vapors, which are a health hazard and a fire danger, keep fuel containers and fuel-powered devices in secure, well-ventilated places. Storage in an unattached shed or garage is safer than storage in a garage attached to your home or in a basement. Keep containers out of traffic areas or off the floor where they can be damaged by your car. Keep them out of reach of children, and make sure the lids are tight to prevent easy access. Consider plugging floor drains if fuel is stored where these are located, because a spill could go down the drain. Further liquids could drive the contamination down to your groundwater.

### Do you check on your fuels or machinery regularly?

Periodically check for leaks from storage containers and fuel-driven devices, especially if they have not been used for some time. A small leak can add up over time. You can keep on top of things with regular inspection and maintenance. Always recycle or safely dispose of engine maintenance products. (See Chapter 3, "Managing Hazardous Household Products.")



## ✓ Assessment 1 – Portable Fuel Containers

Check all the places where you store fuels—garage, basement or shed—and examine how they are stored. Use the assessment below to evaluate your practices. Some choices may not match your situation exactly, but answer the best you can. Write your risk level (low, medium or high) in the column labeled “Your risk.” Refer to Part 1 above if you need more information to complete this chart.

	Low risk/ recommended	Medium risk/ potential hazard	High risk/ unsafe situation	Your risk
<b>Container safety</b>	UL-approved container: Red for gasoline Blue for kerosene Yellow for diesel		Non-approved containers (for example, glass or open containers).	
<b>Storage location</b>	Unattached garage or shed away from house. Well-ventilated. Concrete floor without floor drain. Or, in secondary containment in garage with floor drain.	Garage attached to house. Poorly ventilated area.	Inside the home living space, in basement. Garage floor with floor drain or dirt floor.	
<b>Quantities stored</b>	Moderate amounts purchased. Fuel stored for less than 6 months.	Fuel kept more than 6 months before use.	Excess quantities purchased. Fuel kept more than 12 months.	
<b>Management and disposal</b>	Used up in equipment.	Stored on site indefinitely or evaporated.	Poured down house drain, poured on ground or sent to landfill.	
<b>A boxed risk level</b> indicates level required for Residential Environmental Assurance Program certification.				

### Responding to risks

Your goal is to lower your risks. Turn to the Action Checklist at the end of this chapter and record the medium and high risks you identified above. Use the recommendations in Part 1 above to help you plan actions to reduce your risks. On the checklist, write down changes you plan to make, as well as a schedule for making these changes. You don’t have to do everything at once, but try to eliminate unsafe conditions first. If you need more information, contact local fire officials.

## Part 2 – Large Fuel Tanks (Aboveground, Underground and Basement Storage Tanks)

It is vital to know about fuel storage tanks on your property, both tanks in current use and abandoned ones. As a tank owner, you have many responsibilities and must keep up with increasingly strict laws. You may be financially responsible for leaks from a tank on your property, even if you are unaware of the tank's existence. Standard homeowner's insurance does not typically cover the costly cleanups.

### Part 2a – Tank location

This section covers aboveground, basement and underground tanks. Answer only those questions that apply to you. Remember to assess each tank separately.

Storage tanks located in basements with drains provide a high risk for groundwater contamination should they leak. Therefore, use of either a double-walled tank, pan-type secondary containment under a single-walled tank or concrete floor diking to contain spills and prevent them from entering the floor drain is recommended.

Homeowners sometimes place fuel oil tanks too close to their home. Placement under the eaves has resulted in falling ice damage to tanks, causing fuel loss and environmental cleanup costs. Tanks need to be stably mounted and placed away from risk of vehicular or other impact. The type of tank and fuel will determine the allowed placement distance from buildings. Check with the DEQ before placing your tank.

#### **Tank registration information:**

Motor vehicle fuel tanks larger than 1,100 gallons or for business use need to be registered or certified.

Michigan Department of Environmental Quality (DEQ)  
Waste & Hazardous Materials Division  
Storage Tank Program  
517-335-2690  
deq-std-tanks@michigan.gov

DEQ Storage Tank Information Center:  
[www.deq.state.mi.us/sid-web](http://www.deq.state.mi.us/sid-web)

### How far is your tank from wells and surface waters?

Fifty feet is the minimum distance between your tank and nearby private wells, but the greater the distance, the better. Other factors related to distance can influence the risk. Tanks are safer when located downslope (downhill) from wells. Certain soil types—such as sandy soils—allow pollutants to seep more rapidly into groundwater. The 50-foot minimum also applies to the distance between tanks and streams, wetlands, ponds and other surface waters.

For each high-risk tank, consider removing it or moving it to a location as far from wells and surface waters as possible. If a tank must be near a well or water, aboveground tanks with secondary containment should be chosen. Never try to convert an underground tank into an aboveground tank or vice versa. For professional assistance, look in the yellow pages under “Tank,” “Environmental,” “Petroleum” or “Excavating,” or go to the Michigan Department of Environmental Quality's (DEQ) website listing for DEQ qualified consultants (see “Resources” at the end of this chapter). If it is not possible to remove high-risk tanks, be extra careful to monitor them for spills and leaks.

### What is the distance to the water table?

In most places, if you dig straight down, you will eventually reach water. This water table may be a few feet to more than 50 feet down. This distance is important for several reasons. When water is close to the surface, there is a good chance that it will come into contact with the steel walls of an underground tank. In wet conditions, metal is more likely to corrode, particularly if your soil has corrosive properties. Also, spills will reach the groundwater more quickly if the water table is close to the surface. Your tank may be exposed to similar water problems during flooding.

You can get help finding out about your water table from your local health department or well driller or the Michigan Groundwater Stewardship Program. If you do not know how deep your underground tank is buried, assume it is no more than 10 feet. Again, for each high-risk tank, consider removing it. The cost of removing it and installing an aboveground tank may be far less than paying for a future cleanup.

### ✓ Assessment 2a – Tank Location

For the assessments in Part 2, start by gathering basic information. How many tanks do you have and where are they located? *Assess each tank separately.* Using your records or your memory, reconstruct the history of each tank. When was it installed? Has it been serviced or inspected? Unless you know for sure, it is wise to check for inactive underground tanks.

Evaluate your situation using the assessment below. Write your risk level (low, medium or high) in the column labeled “Your risk.” Refer to Part 2a above if you need more information.

	<b>Low risk/ recommended</b>	<b>Medium risk/ potential hazard</b>	<b>High risk/ unsafe situation</b>	<b>Your risk</b>
<b>Distance from your well</b>	Greater than 100 feet from private water well.	Between 50 and 100 feet from private water well.	Less than 50 feet from private water well.	
<b>Distance from surface water</b>	Greater than 100 feet from wetland, stream, river, pond or lake.	Between 50 and 100 feet from wetland, stream, river, pond or lake.	Less than 50 feet from wetland, stream, river, pond or lake.	
<b>Water table level</b>	Water table (distance to groundwater) consistently more than 10 feet below the surface.	Water table consistently between 5 and 10 feet below the surface.	Water table consistently less than 5 feet below the surface.	
<b>A boxed risk level</b> indicates level required for Residential Environmental Assurance Program certification.				
<i>Continued on next page...</i>				

...Assessment 2a continued

	<b>Low risk/ recommended</b>	<b>Medium risk/ potential hazard</b>	<b>High risk/ unsafe situation</b>	<b>Your risk</b>
<b>Basement tank location</b>	In basement with impervious surface floor without a floor drain or with a closed drain, or tank has secondary containment (double-walled tank, pan or dike).		In basement without impervious surface floor or floor with drain and no secondary containment for tank.	
<b>Distance from building</b>	Fuel oil tank located 5 or more feet from building. Aboveground gas or diesel single-walled tanks for motor vehicle fueling 40 or more feet from building. Underground tanks located 10 or more feet from building.		Fuel oil tank closer than 5 feet, gas or diesel single-walled tank closer than 40 feet or underground tank closer than 10 feet to building.	

**A boxed risk level** indicates level required for Residential Environmental Assurance Program certification.

### Responding to risks

Turn to the Action Checklist at the end of the chapter to record medium and high risks you identified. Use the recommendations in Part 2a to help you plan actions to reduce your risks.

## Part 2b – Fuel tank management

This section deals with all three types of tanks—aboveground, underground and basement. In the information below, review the parts that apply to the tanks you have.

### Is your tank old and possibly leaking?

This is your highest concern. Aboveground tanks should be stably mounted and situated so that the tank itself is not in contact with the ground and thus not as prone to corrosion and leaking. Buried tanks more than 15 years old have a dramatically higher chance of leaking than newer tanks. Underground steel tanks now must have corrosion protection. It is expensive to put corrosion protection on existing tanks—it may be more cost-effective to replace them. Even new tanks and piping can leak, especially if they were incorrectly installed.

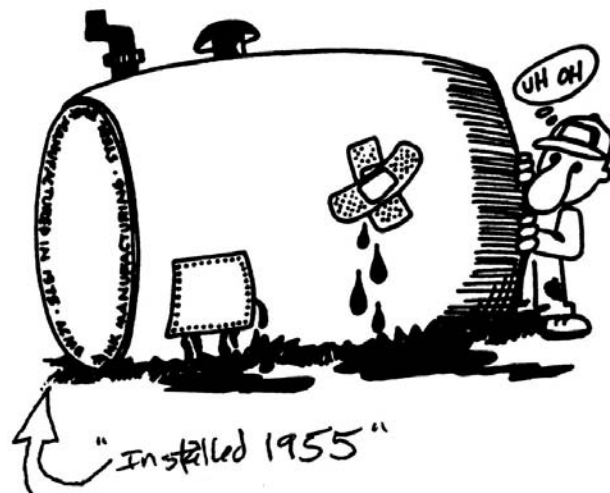



Underground steel tanks must have corrosion protection such as interior tank liners, protective coatings on the tank exterior and cathodic (electrochemical) protection. Fiberglass tanks do not corrode but are vulnerable to ground heaving and installation damage.

Leak detection for underground storage tanks is complicated but is critical for tanks older than 15 years. Set up a schedule for regular leak and damage inspection of all tanks, including heating oil tanks in your basement.

### Have you checked pipes and hoses?

The pipes, hoses, valves and fittings connected to a storage tank can be major sources of leaks. They are often overlooked, especially if buried underground. Here, too, age is a factor. Piping fails because of corrosion, accidents and weather-related factors such as frost heaving. Professional installation and inspection are your keys to avoiding problems.

### What signs of trouble should you look for?

*Environmental changes.* Your senses—sight, smell and taste—are important for leak detection. Is there an unexplained oil-like substance on lakes or streams? Is nearby soil stained with petroleum due to spillage (Figure 2)? Is there a strong and constant smell of petroleum or wet places near your tank? Have you or your neighbors smelled fuel odors near plumbing or sewer line openings or in basements, or have you detected a petroleum flavor in your drinking water? Have you seen an area of dead plants or an area where plants don't grow near your petroleum storage? Normally you can see leaks from an aboveground tank, but you should be aware of leaks in areas you cannot easily see, such as where the tank is in contact with the ground.

*Mechanical changes.* Be aware of unusual or changing pump operation. Does your suction pump rattle, and does fuel flow unevenly? Does the pump hesitate too long before dispensing? These may be signs of leaks or damage to the piping.

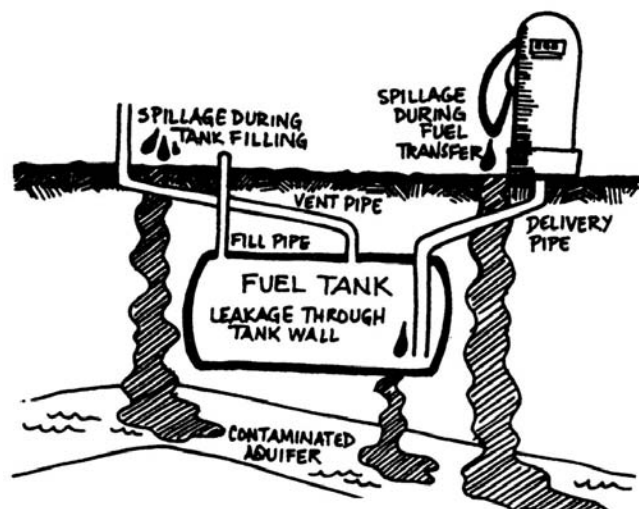

Figure 2: Contamination of groundwater due to improper fuel storage and transfer.

### Have you pressure-tested your tank?

**Tightness testing** (tank and pipe testing) involves placing the tank, piping and contents under pressure and checking for leaks. Many tank owners choose to remove their underground tanks rather than do this testing because it is expensive.

#### Whom to call

For more information on leak detection systems and for names of approved tank testing methods and suppliers, contact the Michigan Department of Environmental Quality Storage Tanks Program at 517-335-2690 or [deq-std-tanks@michigan.gov](mailto:deq-std-tanks@michigan.gov).

### **Do you keep track of fuel levels in the tank?**

A less expensive way to check for leaks is to monitor the level of fuel over time. Measure precisely the amount of fuel in the tank each month and compare with the amount of fuel delivered and dispensed. Differences in your records may indicate a leak. This method is not always accurate, and small leaks will be missed. Underground tanks for heating fuel, because they dispense automatically when in use, are best monitored in summer. If you suspect a problem, contact your local fuel supplier.

### **What spill-protection actions have you taken?**

Overfilling a vehicle is the most common—and most avoidable—cause of spills. Fueling should be done on an impermeable surface. Never walk away while filling a vehicle with fuel. Close supervision of fuel transfers is one of your best forms of protection. Automatic shutoff devices are available to prevent spills but are not suitable for every tank. Spills resulting from overfilling basement (home heating fuel) tanks can be reduced by installing a vent whistle or fill-level indicator. Ask a tank or fuel supplier about these devices.

A concrete pad under an aboveground tank will allow you quickly to see leaks or spills and allow for cleanup. Double-walled aboveground tanks are available that provide secondary containment, should the tank leak.

A spill kit is a wise investment. It can be used to clean up tank overflow spills or equipment fueling spills. See Chapter 9, “Caring for the Yard and Garden,” for a sample spill kit.

### **Is your fuel secure from theft?**

Preventing access to your gasoline and diesel pumps protects against theft and lowers pollutant risks. Unauthorized users can damage your tank or spill fuel. The simplest form of security is to lock your tank fill site and pump or dispenser. Enclosing an aboveground tank with a 6-foot locked fence offers more security.

### **Are your tanks protected from accidents and damage?**

Aboveground tanks can leak if they are not well-supported or protected from damage by vehicles and other objects. Tanks should be placed on a solid, stable base or on footings made of cement blocks or concrete that resist changes in soil moisture and frost heaving. In your basement, do not store anything around or under the heating oil tank. Heavy objects can damage pipes. If your tank is located in a garage or outdoors, it needs to be protected from damage by vehicles. Installation of safety posts or other non-flammable, ventilated barriers around it is recommended.



## ✓ Assessment 2b – Tank Management

Evaluate your situation using the assessment below. Write your risk level (low, medium or high) in the column labeled “Your risk.” Refer to Part 2b if you need more information.

	<b>Low risk/ recommended</b>	<b>Medium risk/ potential hazard</b>	<b>High risk/ unsafe situation</b>	<b>Your risk</b>
<b>Age of your underground tank</b> (gasoline, diesel or heating oil)	Metal underground tank less than 15 years old and protected from corrosion, or fiberglass tank.	Metal underground tank less than 15 years old and not protected from corrosion.	Metal underground tank more than 15 years old.	
<b>Leak detection procedures</b> (underground tanks)	Regular tank tightness testing and monthly fuel use accounting.	Fuel use accounting.	No testing or fuel use accounting.	
<b>Tank leak detection</b> (aboveground tanks)	Tank regularly monitored for leaks. Tank on impermeable surface.	Tank regularly monitored for leaks. Tank not on an impermeable surface.	Tank not regularly monitored.	
<b>Spill and overflow protection</b> (for gasoline or diesel)	Close supervision during tank filling. Equipment fueling done on an impermeable surface.	Automatic shutoff or close supervision but no impermeable surface.	Unattended filling and fueling. No impermeable surface.	
<b>Tank security</b> (for gasoline or diesel)	Tank fill opening plus pump or dispenser (if present) locked.	Fill opening and pump or dispenser lockable.	No locks present. Equipment unlockable.	
<b>Damage protection</b> (aboveground and basement tanks)	Tanks and pumps stably mounted on concrete or on steel supports. Protected from impact damage.	Tanks and pumps stably mounted off the ground but no protection from impact damage.	Tanks in contact with the ground or on poor footings. Tanks vulnerable to vehicles or other damage.	
<b>Spill kit</b>	Spill kit present for tank-filling or equipment-fueling spills.		No spill kit available.	
<b>A boxed risk level</b> indicates level required for Residential Environmental Assurance Program certification.				

### Responding to risks

Use the Action Checklist on page 139 to record your medium and high risks. Plan and take actions to reduce your risks.

## Part 2c – Tank removal and abandoned tanks

Unused tanks may pose the greatest potential risks to health, the environment and financial assets. Sometimes old pumps or fill pipes reveal the location of forgotten tanks. Former owners of the property, neighbors or local fuel suppliers may be able to help locate old tanks.

### Signs of an underground tank

- ◆ Vent pipe (commonly 1-inch diameter) sticking out of ground.
- ◆ Fill pipe, usually 2-inch diameter, with screw top (may be missing) or tilt top.
- ◆ Mounded or sunken soil of somewhat rectangular shape.
- ◆ Site where plants don't grow.
- ◆ Site with darkened soil.
- ◆ Site showing change in soil texture suggesting hole dug for tank placement.
- ◆ Fuel line going out from house wall to unseen tank.
- ◆ Old gas pump present.

### What should you do with an abandoned tank?

Inactive tanks remain an environmental threat until they are emptied and removed. Underground tanks are a special problem because their corrosion and leakage cannot be seen. Even when a tank is thought to be empty, there is often sludge in the tank that can leak out. All of the underground piping must also be removed. Hiring a professional tank remover who has liability coverage is highly recommended. Frequently, tank removal kills or injures non-experts. Contact your local fuel supplier, MSU Extension office or Michigan Groundwater Stewardship Program, or look in the yellow pages under “environmental services” for tank removers. These contractors can help you dispose of the tank at a landfill or with a scrap dealer. After tank removal, the site should be checked for soil and groundwater contamination. If removal of an underground tank might cause hazard to a building's foundation, the tank may be filled with inert material such as sand, cement slurry or pea gravel and left in place.

### What if contamination is discovered?

Tank owners may discover leaks when a tank is removed. Soil around and under a tank should be inspected for obvious signs of leaking—odors, stains or visible fuel. If you suspect contamination, a more extensive site assessment should be promptly arranged. Whenever you find a leak or have a spill, contact the Michigan Department of Environmental Quality Remediation and Redevelopment Division at 517-373-9837 for advice.

To protect yourself against legal claims, you should photograph and document all steps taken to remove a tank. Your written records should include: state agencies contacted, date the tank was filled or removed, persons or companies that did the work, certified records that contamination was not found or, if it was found, detailed records of the resulting site examination.

## ✓ Assessment 2c – Abandoned Tanks

If you have an abandoned or unused tank, evaluate your situation in the following assessment. Write your risk level (low, medium or high) in the column labeled “Your risk.” Refer to Part 2c if you need more information.

	Low risk/ recommended	Medium risk/ potential hazard	High risk/ unsafe situation	Your risk
<b>Tank removed or left in place?</b>	Inactive aboveground tank removed from site or environmentally cleaned and secured from addition of materials. Underground tank removed or filled with inert material if too close to building to be removed.		Inactive tank abandoned and left underground (or aboveground).	
<b>Inspected for contamination?</b>	Tank site checked for contamination of soil and groundwater. If the spill or leak is large enough, special reporting and testing are required.		Site not checked for contamination.	
<b>A boxed risk level</b> indicates level required for Residential Environmental Assurance Program certification.				

### Responding to risks

Use the Action Checklist below to record your medium and high risks. Plan and take actions to reduce your risks.

### ✓ Action Checklist

When you finish the assessments, go back over the questions, find all high and medium risks, and write them below. For each of these risks, write down the improvements you plan to make. To help you decide what to do, use recommendations from this work sheet as well as information from other resources. Pick a target date that will keep you on schedule for making the changes. You don’t have to do everything at once, but try to eliminate the most serious risks as soon as you can. Often it helps to start with inexpensive actions.

Write all high and medium risks here.	What can you do to reduce the risk?	Target date for actions:
Example: Gas for lawnmower stored in a glass jug.	Buy a UL-approved container from the hardware store.	One week from today: May 15.

## Resources

- ◆ **“Handling and Underground Storage of Fuels.”** Michigan State University Extension bulletin WQ01. Available from county MSU Extension offices or online at [www.emdc.msue.msu.edu](http://www.emdc.msue.msu.edu).
- ◆ **“Home Heating Oil Tanks.”** Brochure available from Department of Environmental Quality Environmental Assistance Center, 1-800-662-9278, or [www.michigan.gov/DEQwhmd](http://www.michigan.gov/DEQwhmd). Go to “storage tank” link, then “underground storage tank,” then “home heating oil tanks,” then “FAQ home heating oil tank” for a PDF version of the brochure.
- ◆ **“On-Farm Fuel Storage.”** MSU Extension bulletin WQ59. Available from county MSU Extension offices or online at [www.emdc.msue.msu.edu](http://www.emdc.msue.msu.edu).

### DEQ qualified consultants list:

[www.deq.state.mi.us/sid-web/qc\\_search.aspx](http://www.deq.state.mi.us/sid-web/qc_search.aspx)

### Spills – Contact:

DEQ, Remediation and Redevelopment Division district office in your area or the state office, 517-373-9837.

### Storage – Contact:

DEQ Waste and Hazardous Materials Division Storage Tank Program, 517-335-2690 or [deq-std-tanks@michigan.gov](mailto:deq-std-tanks@michigan.gov).

### U.S. Environmental Protection Agency information:

“Catalog of EPA Materials on Underground Storage Tanks.” Order number EPA510 B00001. National Service Center for Environmental Publications, 1-800-621-8431 or go to [www.epa.gov/nscep](http://www.epa.gov/nscep).

This Home\*A\*Syst chapter does not cover all potential risks related to fuel management that could affect health or environmental quality. Other chapters on a variety of topics help homeowners examine and address their most important environmental concerns.

This chapter was co-authored by Richard Castelnuovo, staff attorney, National Farm\*A\*Syst office, Madison, Wis., and adapted for Michigan by Dean Solomon, Roberta Dow and Jim Bardenhagen, Michigan State University Extension. Updated in 2008.

The 2008 revision of this book was made by Bindu Bhakta, Michigan State University Extension (MSUE); Suzanne Ebright, Michigan Department of Agriculture (MDA); Terry Gibb, MSUE; Rachel Hackett, AmeriCorps-Michigan Groundwater Stewardship Program (MGSP); Matt Swain, AmeriCorps-MGSP; Thomas Cogswell, AmeriCorps-MGSP; and Melanie Stoughton, AmeriCorps-MGSP, and edited by Roberta Dow, MSUE.

Sincere thanks to the following people for reviewing one or more chapters:

Darren Bagley, Natural Resources, Genesee County MSUE  
Valerie Bartell, AmeriCorps-MGSP  
Lynda Boomer, Physical Plant, MSU  
Ron Calhoun, Crop and Soil Sciences Dept., MSU  
Michele Borgialli, Healthy Homes Program, Dept. of Community Health  
William Elgar Brown, Water Bureau, Dept. of Environmental Quality (DEQ)  
Laura DeGuire, Air Quality Division, DEQ  
Lucy Doroshko, Pollution Prevention Programs Unit, DEQ  
David Drullinger, Water Bureau, DEQ  
Richard Falardeau, On-Site Wastewater Unit, DEQ  
Mark Fife, Stormwater, DEQ  
Rebecca Finneran, Horticulture, Kent County MSUE  
Matt Flechter, Waste and Hazardous Materials Division, DEQ  
Mike Gaber, Water Bureau, DEQ  
Lois Graham, Water Bureau, DEQ  
Aileen Gow, Urban Options  
Paul Haan, Healthy Homes Coalition of West Michigan  
Sue Hendershott, Waste & Hazardous Materials Division, DEQ  
Steve Hall, Jackson County Health Department  
Pam Howd, Environmental Assistance Program, DEQ  
Eric Johnson, Michigan Groundwater Stewardship Program, MDA  
Ruth Kline-Robach, Institute of Water Research and Center for Remote Sensing, MSU  
Allen Krizek, Michigan Groundwater Stewardship Program, MSUE  
Michael Kamrin, Center for Integrative Toxicology, MSU  
Steve Kulesia, Pollution Prevention Programs Unit, DEQ  
Joe Lovato, Groundwater Mapping and Contamination Investigation Unit, DEQ  
Judy Schaefer, Environmental Assistance Program, DEQ  
Ruth Shaffer, Natural Resources Conservation Service  
Dean Solomon, Charlevoix County MSUE  
Jenny Stanger, Horticulture, Monroe County MSUE  
Jay Wagar, Healthy Homes Program, Dept. of Community Health

Special thanks to Jenny McKellar, Grand Traverse County, MSUE, for graphics and manuscript preparation as well as a great deal of tenacity.

MICHIGAN STATE  
UNIVERSITY  
EXTENSION

MSU is an affirmative-action, equal-opportunity employer. Michigan State University Extension programs and materials are open to all without regard to race, color, national origin, gender, gender identity, religion, age, height, weight, disability, political beliefs, sexual orientation, marital status, family status or veteran status. Issued in furtherance of MSU Extension work, acts of May 8 and June 30, 1914, in cooperation with the U.S. Department of Agriculture. Thomas G. Coon, Director, MSU Extension, East Lansing, MI 48824. This information is for educational purposes only. Reference to commercial products or trade names does not imply endorsement by MSU Extension or bias against those not mentioned.