

## **MSU Extension Publication Archive**

Archive copy of publication, do not use for current recommendations. Up-to-date information about many topics can be obtained from your local Extension office.

Preventing the Buckling of Thin Wood Panels

Michigan State University

Cooperative Extension Service

Otto Suchsland, Department of Forestry

June 1974

4 pages

The PDF file was provided courtesy of the Michigan State University Library

**Scroll down to view the publication.**

# Preventing the Buckling of Thin Wood Panels

By Otto Suchsland, Department of Forestry

## What is Buckling?

Most people know from experience that when a long, slender beam or rod is compressed endwise (axially) it will, when the compressive force becomes large enough, suddenly become unstable and bend sideways (Figure 1). This sudden deflection of a rod under compression is called buckling. Buckling is not limited to axially loaded rods or beams but may also occur in thin plates which are subjected to edgewise compression.

Buckling will render a structural compression member useless and may often lead to its destruction. In many applications of thin wood panels, however, buckling is not so much a structural as an appearance problem. Buckled doorskins, for example, are unsightly and will always cause rejection. To the manufacturer of doors or other products involving thin panels, buckling is a puzzling and difficult problem for two reasons.

First, if buckling does occur, it will generally occur in service, after the product has been sold and installed. Secondly, buckling is a 'threshold phenomenon', it does not occur gradually; when it occurs, it is always so noticeable as to be objectionable. Often, slight, sometimes unnoticed variations in the manufacturing process or in the raw material characteristics will result in large batches of entirely unsatisfactory products.

This bulletin describes the phenomenon of buckling in terms of the contributing factors and presents ways of preventing it.

## Mechanics of Buckling

### a) external forces

Buckling of the column illustrated in Figure 1 results from the application of an external force of sufficient magnitude. If that force 'P' would be

gradually increased from zero, the column would initially remain straight, but would be compressed slightly. That is, it would become a little shorter (Figure 2 a, b). This compression deformation would increase as the applied force 'P' increases. At a certain 'critical' deformation value, any further load increase would cause the column to buckle (Figure 2 c, d).

For a given length and a given cross section of the column, the critical deformation value is the same for all materials. If this deformation is divided by the length and multiplied by 100, the following relationship results (square column, both ends clamped), giving the critical compression deformation in percent of the length of the column:

$$\frac{e_{\text{crit.}}}{l} \cdot 100 = \epsilon_{\text{crit.}} = c \cdot \left[ \frac{h}{l} \right]^2 \quad [\%] \quad (1)$$

### Where:

- $e_{\text{crit.}}$  = critical deformation of square column with both ends clamped (in.)
- $l$  = length of column (in.)
- $\epsilon_{\text{crit.}}$  = relative critical deformation (%)
- $h$  = thickness of column (in.)
- $c$  = constant

This means the smaller the thickness/length ratio, the smaller is the compression deformation at which buckling will occur, which verifies everyday experience: the longer and thinner a rod, the more it is prone to buckling. Conversely, at large enough thickness/length ratios, buckling would never occur, because the column would fail in compression before the critical compression de-

formation was reached.

Formulas, similar to the one above, can be derived for thin rectangular plates loaded edgewise in one direction or in both directions simultaneously. They all contain the term  $\left[\frac{h}{l}\right]^2$ .

b) *internal forces*

Thin wooden panels are hardly ever exposed to external compressive forces as discussed above, but might buckle because of swelling of the panel in high relative humidity. This linear expansion of the panel is often restrained by a wooden frame, a condition, which leads to the development of 'internal' forces and to a loading situation equivalent to the one caused by external forces. This equivalence is very important to the understanding of the type of buckling problems encountered with thin wooden panels and shall be explained below.

Figure 3a shows the edge of a wood panel of

length 'l' before being exposed to a high relative humidity. During exposure to high relative humidity the length 'l' increases due to swelling, by the amount 'a'. There is no restraint on the panel. By applying a sufficient force 'P' to the edge of the expanded panel, its length could be reduced to its original dimension 'l' (Figure 3b).

Figure 3c shows a panel which is held between two frame members which restrain it from expanding during exposure to high relative humidity. Conditions 'b' and 'c' are equivalent. Upon removal of force 'P' in Figure 3b and removal of the restraining frame in Figure 3c, both panels would expand by the increment 'a' as shown in Figure 3a. The 'free expansion' is normally expressed in percent of the length 'l', by dividing it by 'l' and multiplying by 100:

$$\frac{a}{l} \cdot 100 = \alpha \text{ [%]} \quad (2)$$

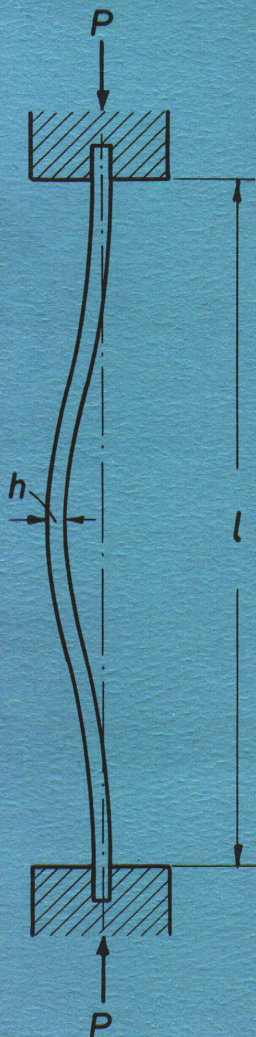
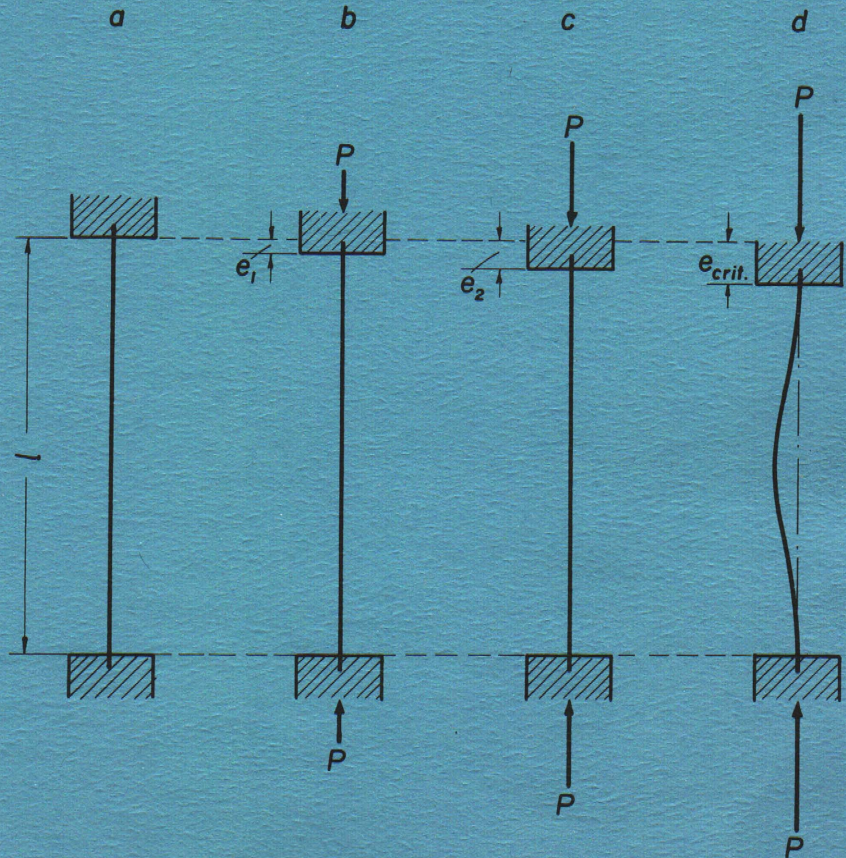

Figure 1. (Left) Buckling of a column under compression.

Figure 2. Progressive deformation and eventual buckling of column under increasing load.



If this free swelling ' $\alpha$ ' exceeds the critical compression deformation ' $\epsilon_{crit.}$ ':

$$\alpha \geq \epsilon_{crit.} = c \left[ \frac{h}{l} \right]^2 \quad [\%] \quad (3)$$

then the panel shown in Figure 3b would buckle, so would the panel in Figure 3c and the two skins in Figure 3d which are shown glued to a wooden door frame.

The free expansion or swelling of wooden panels like plywood, hardboard or particleboard can readily be measured or found in tables. Its magnitude depends, of course, also on the severity of the exposure. Table 1 contains a list of expansion values for a variety of panel materials.

### Designing for Stability

Figure 4 is a graphical representation of equation 3 for a square panel with edges clamped. The numerical values used in this graph are based on certain theoretical assumptions and cannot be directly applied to most practical situations. The graph can be used, however, to illustrate how the variables involved may be manipulated in order

to insure troublefree performance of thin panels or to correct conditions that result in buckling.

**Example:** A 1/4 in. thick panel material (a) is found to expand 0.15% (b) as the relative humidity is varied from 35% to 85%. This condition is shown on the graph by the intersection of lines (a) and (b) between curves  $l = 10$  in. and  $l = 20$  in. This location indicates that if the dimensions of the restrained panel were 20 in. x 20 in. it would buckle but if they were 10 in. x 10 in. the panel would remain flat. In order to prevent buckling of the larger panel, the thickness could be increased to 0.36 in (c), or the expansion could be limited to 0.75% (d). Each of these two measures would bring the intersection of the two lines to fall on the  $l = 20$  in. curve and thus prevent buckling.

A change in expansion could be affected by selecting a different material, like plywood instead of hardboard, or by specifying a lower density hardboard rather than standard board. It might often be easier, however, or more economical, to stabilize the panel by increasing its thickness.

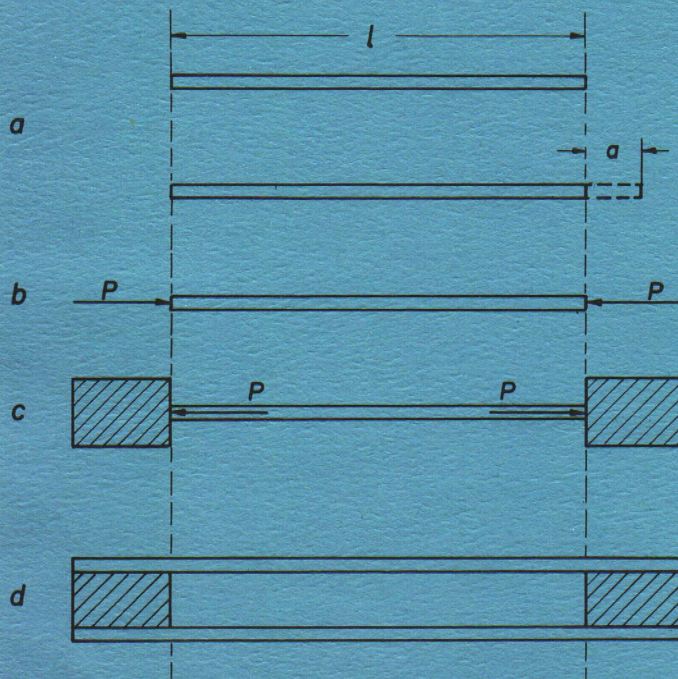

Figure 3. Development of internal forces due to restrained swelling of thin panels.

Table 1. Free expansion of selected panel materials.

Product	Thickness (in.)	Expansion <sup>1</sup> (%)
Fir plywood, 3-ply	3/8	.0060
Fir plywood, 3-ply	1/2	.0056
Fir plywood, 5-ply	3/4	.0076
SYP plywood, 4-ply <sup>2</sup>	3/4	.0054
SYP plywood, 7-ply	3/4	.0110
Hardboard A,	3/8	.0327
Hardboard B, S <sup>3</sup>	1/4	.0216
Hardboard B, T <sup>4</sup>	1/4	.0368
Hardboard C, S	1/8	.0338
Hardboard C T	1/8	.0352
Hardboard D S	1/4	.0645
Hardboard D T	1/4	.0664
Particleboard A	1/2	.0089
Particleboard B	3/4	.0281
Particleboard C	3/4	.0333
Particleboard D	3/4	.0350
Particleboard E	3/4	.0378
Particleboard F	3/4	.0431
Particleboard G	3/4	.0463
Particleboard H	3/4	.0516
Particleboard I	3/4	.0559
Particleboard J	3/4	.0633

<sup>1</sup>Linear expansion per one percent moisture content change

<sup>2</sup>Southern Yellow Pine

<sup>3</sup>Standard hardboard

<sup>4</sup>Tempered hardboard

It is, of course, imperative that once sound constructions have been developed that panel thickness, expansion values, and moisture contents at the time of assembly or installation be continually monitored.

### Buckling and Stress Relaxation

Under certain conditions the buckling of wood based panels caused by restrained swelling will disappear when the product is allowed to redry to its original moisture content. In other instances, like in the case of some hardboards, the internal forces, that cause the buckling in the first place, will diminish with time (relaxation). In these cases, subsequent redrying or even removal of the restraint will not restore the panel to its original flat shape.

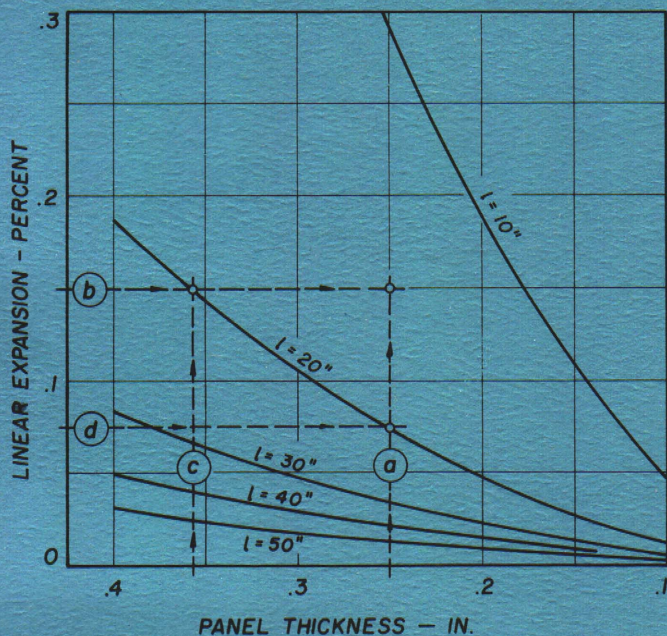

Figure 4. Critical expansion values of square panels of various sizes and thicknesses.