

## **MSU Extension Publication Archive**

Archive copy of publication, do not use for current recommendations. Up-to-date information about many topics can be obtained from your local Extension office.

How much lumber in that tree?  
Michigan State University  
Michigan State University Extension  
Now E-2915  
Lester E. Bell, Forestry  
Issued July, 1971  
3 pages

The PDF file was provided courtesy of the Michigan State University Library

**Scroll down to view the publication.**

84

107

85

?

99

251

230

?

79

?

127

# HOW MUCH LUMBER IN THAT TREE?

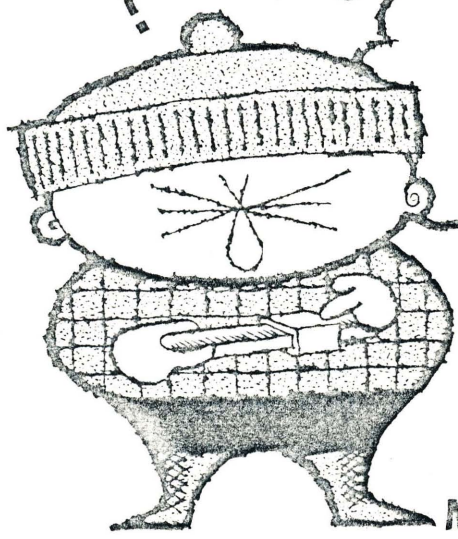

MICHIGAN STATE UNIVERSITY

COOPERATIVE EXTENSION SERVICE  
EAST LANSING

EXTENSION BULLETIN 461  
NATURAL RESOURCES SERIES  
JULY, 1971

BY LESTER E. BELL  
Department of Forestry

A WOODLAND OWNER often has occasion to determine the board foot volume of certain trees in his woodlot. He may wish to obtain lumber for building purposes or for sale. By measuring the volumes of standing trees he can choose one that is the proper size, enough trees of different sizes to provide the desired amount of lumber. At the same time he can avoid felling more trees than necessary.

Frequently, there are opportunities to sell a quantity of mature trees. The timber grower should know the number of board feet he is selling before the sale is made.

This folder tells how to estimate the amount of lumber in a tree with easy-to-make tools.<sup>1</sup> A landowner can determine the board foot content of his trees by following a few simple rules. *If an estimate of the entire woodlot is needed, however, the owner is advised to contact his area forester, or a consulting forester, for this service. He should not attempt this himself because special techniques are involved.*

Sawtimber is measured and sold in terms of board feet, a unit of lumber measuring 1 inch thick, 1 foot wide, and 1 foot long. In order to determine the board foot contents of standing trees, their diameters and usable heights must first be measured. The volumes of the trees can then be found in Tables 2, 3, and 4 of this folder.

### Measuring Diameter

Diameters of trees are measured at breast height, 4½ feet above the average ground level. A Biltmore stick for measuring diameters can be prepared in the home workshop, using a straight piece of hardwood that is free from knots or other defects, as shown in

Fig. 1. The stick should be 30 inches long, ½ inch thick, and 1½ inches wide. It should be beveled on one edge.

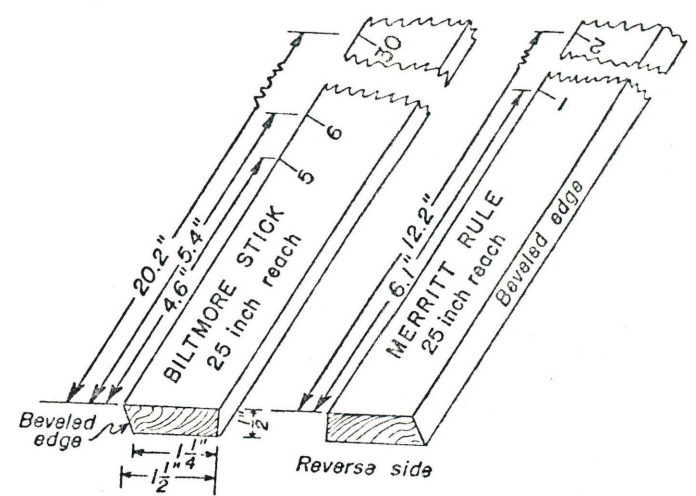

Fig. 1. Dimensions of Biltmore stick with Merritt rule on reverse side.

Sand the sides and edges of the stick smooth. The stick is then graduated on the unbeveled side according to the figures given in Table 1.

Table 1. Biltmore Rule Graduations

Diameter graduations on stick	Distance in inches from end of stick to diameter graduations	Diameter graduations on stick	Distance in inches from end of stick to diameter graduations
5	4.6	18	13.7
6	5.4	19	14.3
7	6.2	20	14.9
8	7.0	21	15.5
9	7.7	22	16.0
10	8.4	23	16.6
11	9.2	24	17.1
12	9.8	25	17.7
13	10.5	26	18.2
14	11.2	27	18.7
15	11.8	28	19.2
16	12.5	29	19.7
17	13.1	30	20.2

<sup>1</sup>The Biltmore stick may also be purchased from Forestry Supply Houses.

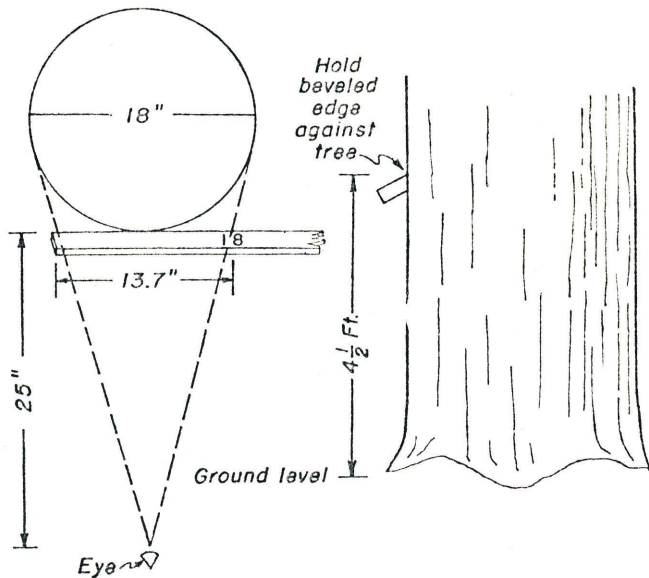

Fig. 2. Measuring tree diameter with Biltmore stick.

Measure tree diameters with the Biltmore stick in the following way (see Fig. 2):

- (1) Hold the stick in a horizontal position so that there is a distance of 25 inches from the eye to the stick. Hold the beveled edge of the stick against the trunk of the tree at breast height.
- (2) Look straight at the tree without moving your head from side to side. Adjust the stick so that the left or zero end is in line of sight with the left side of the tree (see Fig. 2).
- (3) Without moving your head, shift the line of sight to the right hand side of the trunk.
- (4) Read the diameter on the stick nearest the point at which the line of sight crosses it.

### Measuring Height

Tree heights are measured in units of 16-foot logs or fractions thereof. In slender, straight trees, this measurement is taken to a point on the tree where the diameter is 8 inches, inside bark. However, with older trees, excessive branching or forks may reduce the usable height. One should then measure the distance between stump height and usable height.

A Merritt rule for measuring tree heights can be inscribed on the reverse side of the Biltmore stick; then both rules, one for measuring tree diameter and the other for measuring tree height, will be on the same stick.

To inscribe the Merritt rule on the stick, simply mark graduations of 6.1 inches from the zero end of the stick (see Fig. 1). Each graduation represents a 16-foot log length. Inscribe half-log marks halfway between the 16-foot log marks. Make the graduation for both the diameter scale and the height scale with a sharp indelible pencil. Use the pencil dry. Then give the stick a coat of white shellac. This will bring out the color of the indelible lead, as well as protect the stick from moisture and discoloration.

Measure tree heights with the Merritt rule by the following method (see Fig. 3):

- (1) Stand 66 feet from the base of the tree. Hold the stick vertically at a distance of 25 inches from your eye.
- (2) Adjust the stick so that the zero end is in the line of sight with the upper limit of usable height.
- (3) Without moving your head or the stick, shift your line of sight to the stump height at the base of the tree (usually 12 to 16 inches above ground level). From the scale, read the number of logs (or fractions of logs) in the tree.

If the ground is not level, stand on a spot which has about the same elevation as the base of the tree

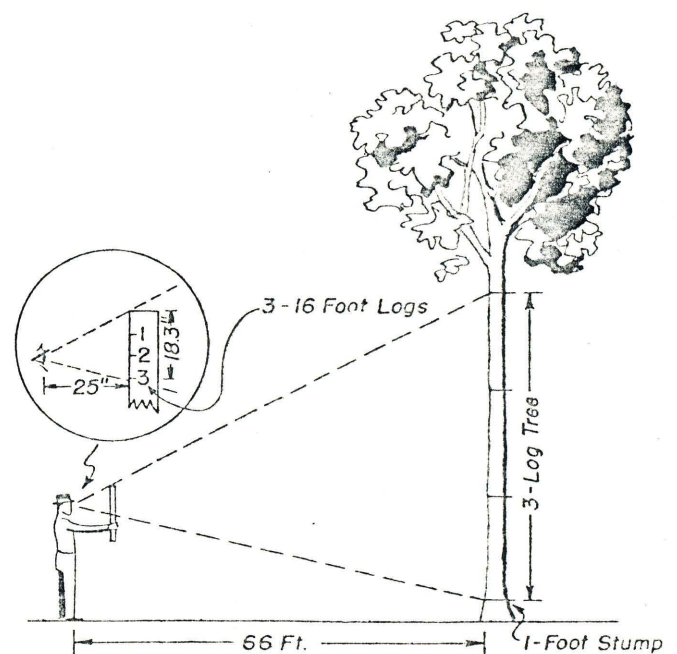

Fig. 3. Measuring tree height in 16-foot log units with Merritt rule.

## Determining Tree Volume

After the diameters and heights of the trees have been measured, the board foot content for each tree can be read from a volume table. Table 2 gives tree volumes based on the International log rule. This rule gives a very accurate measure of the amount of lumber that a sound, straight tree will yield at the mill.

Tree volumes based on the Doyle rule are given in Table 3. Sometimes local custom demands the use of this rule when standing timber is sold. Table 4 gives tree volumes based on the Scribner Decimal C rule. Often local custom, especially in the Upper Peninsula of Michigan, demands that this rule be used.

If you are going to fell the trees yourself and haul the logs to the mill, read the board foot values in Table 2 for the International rule. However, if you are selling standing trees in the Lower Peninsula of Michigan, (and if the buyer insists), use the values given in Table 3. If your trees are in the Upper Peninsula and the buyer demands it, use the values based on the Scribner Decimal C rule (Table 4).

In using these tree volume tables, increase the volumes by 10 percent for the following trees: Balsam fir, spruce, white oak, yellow poplar, black cherry, beech and ash. Also, make suitable deductions for visible defect.

Table 2.

Diameter 4½ feet above ground	Number of 16-foot logs			
	1	2	3	4
(inches)	Volume in board feet			
10	35	60		
11	45	75		
12	55	90	120	
13	65	110	145	
14	80	130	175	
15	90	155	200	
16		180	240	285
17		205	280	330
18		235	315	375
19		265	360	425
20		295	400	480
21		330	450	540
22		370	500	605
23		405	550	665
24		440	605	725
25		485	665	800
26			725	880
27			790	950
28			850	1030
29			920	1110
30			990	1200

Table 3.

Tree Volume Table Based on Doyle Rule

Diameter 4½ feet above ground	Number of 16-foot logs			
	1	2	3	4
(inches)	Volume in board feet			
10	15	20		
11	20	30		
12	30	45	50	
13	40	60	70	
14	50	75	95	
15	60	95	120	
16		115	150	170
17		140	180	210
18		165	215	250
19		195	255	300
20		225	295	350
21		260	345	400
22		295	390	460
23		330	445	520
24		370	495	580
25		415	560	660
26			620	740
27			685	815
28			750	890
29			825	980
30			900	1070

Table 4.

Tree Volume Table Based on Scribner Decimal C Rule\*

Diameter 4½ feet above ground	Number of 16-foot logs			
	1	2	3	4
(inches)	Volume in board feet			
10	3	4		
11	4	6		
12	5	8	10	
13	6	9	12	
14	7	11	15	
15	8	14	18	
16		16	21	25
17		18	25	29
18		21	28	33
19		24	32	38
20		27	36	43
21		30	41	49
22		34	46	55
23		37	51	61
24		41	56	66
25		45	62	74
26			68	81
27			74	89
28			80	96
29			86	104
30			93	112

(\*The figures shown in this table must be multiplied by 10 to obtain board foot values.)