

## **MSU Extension Publication Archive**

Archive copy of publication, do not use for current recommendations. Up-to-date information about many topics can be obtained from your local Extension office.

Using Chemigation Safely and Effectively  
Cooperative Extension Service  
G.W. Bird,  
Issued April 1988  
32 pages

The PDF file was provided courtesy of the Michigan State University Library

**Scroll down to view the publication.**

\$1.50

# Using Chemigation Safely and Effectively

Extension Bulletin E-2099  
New, April 1988  
Cooperative Extension Service  
Michigan State University

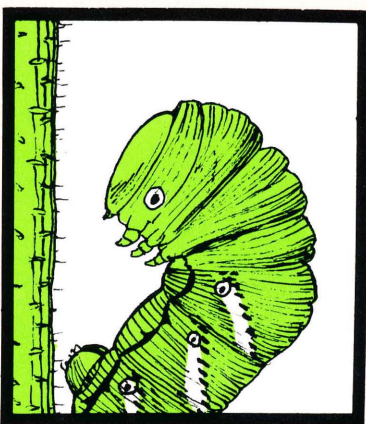
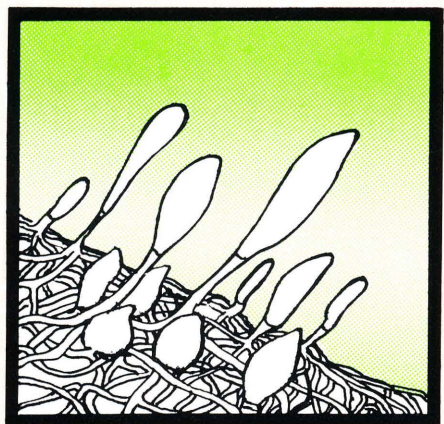
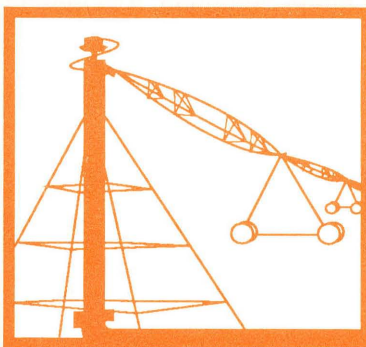

Cover design and illustration  
by Peter H. Carrington

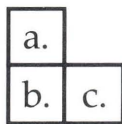

- a. *Amaranthus retroflexus* L.—Common amaranth
- b. *Venturia inaequalis* Fries—Apple scab
- c. *Manduca quinquemaculata* (Haworth)—Tobacco hornworm

## PREFACE

During the past five years there has been a significant increase in the application of agricultural chemicals through irrigation systems. This has become known as chemigation. It usually involves the application of either pesticides or fertilizers. Chemigation is a high technology practice. It should only be undertaken by a properly trained chemigation expert.

The manual entitled "Using Chemigation Safely and Effectively" was developed at the University of Nebraska-Lincoln. It is an excellent document, and outlines the chemigation technology safety practices necessary to prevent ground or surface water contamination. It also provides instructions for the calibration of center pivot irrigation systems for use in chemigation. Safety precautions and calibration procedures are similar for traveler and solid-set irrigation systems. The manual is not designed for use with trickle irrigation.

It is highly probable that within the next five years, chemigation standards will be developed, approved and implemented by both our state and federal governments. The regulation will most likely mandate a separate pesticide applicator certification category for chemigation, and require specific chemigation system safety standards. There is also current discussion about possible licensing of irrigation equipment used for chemigation.

Metham (N sodium methyldithiocarbamate) is currently the most commonly used pesticide applied in Michigan through chemigation. This procedure has been used successfully in potato production for control of soil-borne fungi and nematodes. Most of the applications have been on mineral soils. There is currently interest in using chemigation in strawberry, muck vegetable and ornamental production. Chemigation is likely to increase in Michigan during the next five years. Chemigation can be risky to the quality of our natural resources if it is not used properly. It is imperative that *all* proper safety precautions be taken in *all* applications of agricultural chemicals through irrigation systems.

G. W. Bird  
29 March 1988

## ACKNOWLEDGEMENTS

This manual was produced at the University of Nebraska–Lincoln as part of a chemigation educational resources development project. The project was funded through cooperative agreements with Extension Service, U.S. Department of Agriculture and the U.S. Environmental Protection Agency. The content is drawn substantially from papers presented at a Chemigation Safety Conference conducted as part of the project in April 1985 at the Nebraska Center for Continuing Education, Lincoln. Sections of this manual on calibrating stationary sprinklers, surface systems and drip or trickle systems were adapted from “Application of Herbicides Through Irrigation Systems” (December 1983) by A. G. Ogg, Jr., C. C. Dowler, A. R. Martin, A. H. Lange, and P. E. Heikes.

Special appreciation is extended to the members of the national advisory committee whose names and affiliations appear on the following page. They have been the source of invaluable assistance with this project from its inception, providing comments and insights not only on this manual, but also on the content of two related slide-tape programs: “Chemigation Equipment” and “Chemigation Calibration.”

The first of the several drafts from which this manual has evolved was prepared by Rodney Stoakes. The editors gratefully acknowledge his contribution to this project.

Special thanks are also extended to Valmont Industries, Inc., Valley, Nebraska, for permission to reprint in Appendix A two pages from the Valmont Design Guide on calculating irrigated acreage.

### EDITORS:

DeLynn R. Hay  
Edward F. Vitzthum  
John F. Witkowski  
Emery W. Nelson

Illustrations in this manual include trade named products and equipment. No endorsement of those products and equipment is intended nor is criticism implied of any similar products and equipment which are not illustrated.

## National Chemigation Safety Advisory Committee

Timothy L. Amsden  
Office of Groundwater Protection  
EPA, Region VII  
Kansas City, Kansas

Thomas Delaney  
Georgia Department of Agriculture  
Atlanta, Georgia

Clyde C. Dowler  
USDA-ARS-Agronomy Dept.  
Coastal Plain Experiment Station  
Tifton, Georgia

Ted L. Loudon  
Associate Professor  
Agricultural Engineering  
Michigan State University  
East Lansing, Michigan

Bruce Monke  
Dow Chemical  
Omaha, Nebraska

Richard G. Myers  
Formerly with Valmont Industries  
Fremont, Nebraska

Alex G. Ogg, Jr.  
USDA-ARS Weed Science Research Unit  
Washington State University  
Pullman, Washington

Michael T. Olexa  
Director-Agriculture & the Law Project  
Pesticide Use & Impact Assessment  
University of Florida  
Gainesville, Florida

James V. Parochetti  
Extension Service-  
U.S. Department of Agriculture  
Washington, DC

Stan Pilcher  
Area Extension Agent  
Washington County Extension Office  
Akron, Colorado

H. S. Potter  
Professor Emeritus, Plant Pathology  
Michigan State University  
East Lansing, Michigan

Earle Raun  
Pest Management Co.  
Lincoln, Nebraska

George Rehm  
Extension Scientist, Soil Fertility  
University of Minnesota  
St. Paul, Minnesota

E. Dale Threadgill  
Agricultural Engineering  
Coastal Plain Experiment Station  
Tifton, Georgia

Allen F. Wiese  
Professor of Weed Science  
Texas Agricultural Experiment Station  
Bushland, Texas

John R. Young  
Research Entomologist  
USDA-ARS-IBPMRL  
Tifton, Georgia

# TABLE OF CONTENTS

Acknowledgements .....	i
National Chemigation Safety Advisory Committee .....	ii
Introduction.....	1
Laws and Regulations .....	2
Federal Laws and Regulations.....	2
State Laws and Regulations .....	3
Factors in Deciding to Chemigate.....	4
Irrigation System Location.....	4
Soil Type .....	4
Topography .....	4
Irrigation System Characteristics .....	5
Drift and Runoff Potential .....	5
Calibration .....	5
Irrigation Systems .....	6
Sprinkler Systems .....	6
Surface Systems .....	6
Drip or Trickle Systems .....	6
Equipment .....	8
Supply Tank.....	8
Injection Pump .....	8
Calibration Tube .....	10
Antipollution/Safety Devices .....	10
Calibration Procedures.....	13
Measuring Equipment.....	13
Calibration Equipment .....	13
Calibrating the Center Pivot Irrigation/Chemigation System .....	13
Calibrating a Stationary Sprinkler System.....	15
Calibrating a Surface Irrigation System.....	17
Calibrating a Drip or Trickle System.....	17
Management.....	19
Equipment Maintenance and Inspection .....	19
Read and Comply with Product Label.....	19
Monitoring .....	19
Plug First Nozzles on Center Pivots .....	19
Accidental Spills .....	19
Nontarget Application .....	20
Application to Surface Water .....	20
Runoff—Deep Percolation .....	20
Flushing Injection Equipment .....	20
Flushing Irrigation Equipment .....	20
Protective Clothing and Equipment.....	20
Reentering Treated Areas.....	21
Drip/Trickle Procedures .....	22
Appendix A.....	A-1

## INTRODUCTION

Many agricultural producers are using irrigation systems to apply both water and agricultural chemicals. This practice, commonly called chemigation, can be defined as application of an agricultural chemical by injecting it into irrigation water. Chemicals being applied include: fertilizers, herbicides, insecticides, fungicides, nematicides, and growth regulators.

Just as there are benefits and risks associated with applying agricultural chemicals using conventional (ground or aerial) methods, there are benefits and risks associated with chemigation. The most significant risk is potential contami-

nation of the irrigation water supply. To minimize risks related to chemigation, an irrigation system must be properly equipped and operated. Antipollution equipment must be added to the system and procedures followed to ensure operator and environmental safety as well as desired results of the chemical application.

The purpose of this manual is to provide information needed to chemigate safely and effectively. It is intended only to supplement operator's manuals for irrigation and chemical injection systems.





## LAWS AND REGULATIONS

Both federal and state laws and regulations affect the practice of chemigation. Laws, regulations, court decisions and administrative rulings pertaining to the use of agricultural chemicals and chemigation are subject to constant change. Accordingly, they will be discussed here only in general terms. To be certain that you are in full compliance, check periodically with the regulatory agency in your state that monitors use of agricultural chemicals.

### Federal Laws and Regulations

#### *Federal Insecticide, Fungicide and Rodenticide Act*

All pesticide applications, including those made through an irrigation system, are subject to provisions of the Federal Insecticide, Fungicide and Rodenticide Act (FIFRA) as amended. FIFRA provisions that will affect an applicator include requirements to:

1. use pesticides only as directed by the label;
2. be a certified pesticide applicator or be supervised by a certified applicator if you plan to purchase or use any pesticide classified "For Restricted Use Only." (To become certified, a pesticide applicator must demonstrate his/her competence. For example, a private applicator (i.e. a farmer) may be required to complete a training program and/or successfully complete a worksheet/examination. A commercial (for-hire) applicator must, at a minimum, successfully complete written examinations and, depending upon the state, may also be required to complete training programs. The pesticide applicator training and certification program and chemigation training are totally separate requirements. Being a certified pesticide applicator does *NOT* exempt a producer who plans to chemigate from completing a required chemigation training program. Similarly, a required chemigation training program does not exempt a producer who plans to use "Restricted" pesticides from the need to complete a pesticide applicator training program.)

#### *Pesticide Labels*

The label of a pesticide (i.e. the document af-

fixed to the pesticide container along with any supplemental labeling that may be provided) constitutes a legal document. *It has the same force as federal law.* Using any pesticide in a manner inconsistent with its labeling is a violation of FIFRA and can result in legal actions being taken against you. *Before buying or using any pesticide, therefore, it is important that you first read completely and fully understand the product label.*

#### *FIFRA Exemptions*

In general, a producer may apply a pesticide by any method not specifically forbidden by the label. However, in its efforts to ensure environmental safety, the U.S. Environmental Protection Agency (EPA) has adopted a policy restricting the methods by which some pesticides can be applied. Check the label of the product you want to use to be certain that it may legally be applied through an irrigation system.

The site (crop) on which you wish to apply a pesticide must appear on the label. It is a violation of FIFRA to use a pesticide if the crop is *not* listed on the label. A pesticide may be applied against any pest occurring on any crop, animal or site specified on the label *unless* use of the pesticide is limited only to those pests specified on the labeling.

Applying more pesticide than the label specifies also violates FIFRA. To be certain that you are using the proper rate, it will be necessary to calibrate your chemigation system. Procedures



Read the product label completely before applying any pesticide.

for doing this are described in Chapter 3. It is permissible, however, to apply a pesticide at any dosage, concentration or frequency *less* than that specified on the labeling.

#### *Federal Water Pollution Control Act*

Amendments to the federal Water Pollution Control Act generally provide authority to the federal government only over *surface* waters. If surface waters (streams, rivers, lakes, etc.) are used as an irrigation water source, any pollutant discharge (i.e. pesticides or fertilizers) incident to chemigation operations may subject the violator to federal prosecution. In most states, regulation of pollutant discharges into *ground* water is provided through state programs approved under the Water Pollution Control Act.

#### *Federal Safe Drinking Water Act*

There may be cases in which an irrigation well is situated in close proximity to a municipal water well. Any backflow of water and/or chemicals that enters an aquifer which is, or could be, used as a public drinking water source is a violation of the federal Safe Drinking Water Act. Laws in some states may prohibit chemical injections into irrigation systems if the irrigation water is drawn from a well within a given distance of a public drinking water source. If your irrigation system

is connected to a public drinking water source, special equipment, such as a reduced-pressure principle backflow prevention assembly, may be required.

#### *Resource Conservation and Recovery Act*

Disposal of pesticides or pesticide contaminated materials, such as containers and rinsate, is subject, under some conditions, to the requirements of the Resource Conservation and Recovery Act. Be sure to follow label directions carefully in disposing of such materials.

### **State Laws and Regulations**

Laws in several states impose a variety of requirements such as specific antipollution safety devices, registration of chemigation sites, posting fields that are chemigated, and training and licensing of producers who use chemigation. It is vitally important, therefore, that producers become familiar with provisions of ALL applicable laws and regulations and local ordinances *before* chemigating.

Because of variability between states, this section of the manual will not address state laws. A section on chemigation laws and regulations in your state may have been added to this manual. If so, *study it carefully and be certain that you are in full compliance.*





Problems resulting from spray drift can be reduced by monitoring wind.

not corrected, your irrigation system may be unsuitable for chemigating.

#### *Irrigation System Characteristics*

Physical characteristics of an irrigation system can affect the capacity for applying agricultural chemicals. All irrigation systems can be used to apply fertilizers or pesticides that must be incorporated into soil. However, only a sprinkler system can be used where foliar application is needed. System characteristics have a direct effect on overall efficiency of the chemical application. Any system used to chemigate must have the appropriate injection equipment and anti-pollution safety devices installed, and the entire system must be in good working order.

#### *Drift and Runoff Potential*

Drift and runoff are two leading causes of inadvertent losses from chemical applications. Environmental conditions during application, type of sprinklers installed on sprinkler systems, type and formulation of chemical being applied, and climatic conditions following irrigation are factors affecting magnitude of chemical losses.

—**Drift.** When water emerges as spray from a sprinkler nozzle, part of it may evaporate within the wetted area. Part is intercepted by vegetation and/or soil and part may be carried by wind outside the treated area where it is deposited on a variety of nontarget sites (vegetation, soil, water, structures, etc.). Wind can quickly create a potentially hazardous drift problem. A producer is responsible for monitoring the weather when chemigating. If the wind is strong enough to cause any off-target application, shut down your system.

—**Runoff.** Runoff can potentially occur whenever the irrigation system is applying water at a rate greater than the soil intake rate (the rate at which water enters the soil). The occurrence of runoff depends not only on the irrigation system application rate and soil intake rate, but is influenced by factors such as the field slope, soil surface roughness, and the presence of a crop canopy or residue. Chemigation runoff that leaves the field being treated is a potential hazard to ground and surface water supplies, livestock, adjacent crops and wildlife.

Relatively high application rates are characteristic of the outer portion of center pivot irrigation systems, especially those operating at low pressures. Depending upon the type of chemical being applied and soil characteristics, the amount of water being used to apply the chemical may need to be adjusted to prevent runoff.

In general, sprinkler systems selected to prevent runoff of water under normal operation will be satisfactory for chemical applications.

#### *Calibration*

Accurate calibration of the application system is critical. Unless the system is calibrated, there is no way to determine whether the amount of chemical applied is too much, too little, or—by chance—just right. Overapplication is needlessly expensive and if you are applying a pesticide, you could be prosecuted for misuse of a pesticide. Underapplication frequently does not provide the effect needed. See the section on Calibration Procedures for additional information.

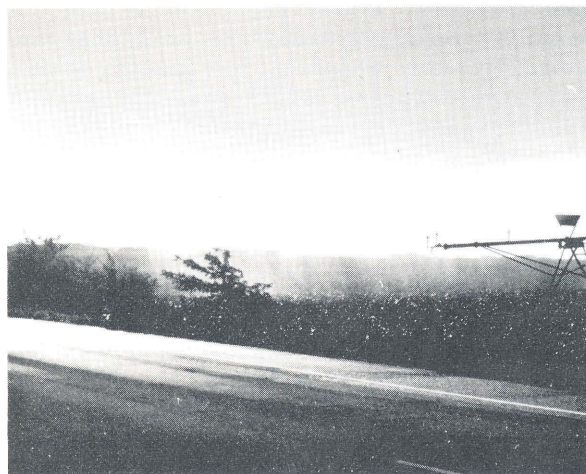

Chemical applications to any nontarget site subjects producers to prosecution.

# IRRIGATION SYSTEMS

The three basic types of irrigation systems are:

- sprinkler
- surface
- drip or trickle

## *Sprinkler Systems*

Sprinkler systems are the most commonly used and are best suited for chemigation. The sprinkler systems include:

- center pivot
- self-propelled linear or lateral move
- solid set
- hand move lateral
- side roll lateral
- tow-line lateral
- traveling big gun

This manual will focus mainly on procedures for center pivot sprinkler systems.

*Center pivot* and *self-propelled linear* systems are the best sprinkler systems for chemigation. Properly designed, calibrated and operated, they provide a high degree of uniformity in water and chemical application.

Center pivots have a high instantaneous rate of water application near the outer portions of the circle. If the infiltration rate of the soil is exceeded, runoff of chemical-water solution may occur. Therefore, the center pivot sprinkler package should be selected to minimize runoff potential. Work with the irrigation system dealer and/or Soil Conservation Service and Cooperative Extension Service personnel to select a sprinkler package to match the field being irrigated. In many situations, the quantity of irrigation water applied will be small enough that runoff may not be a major concern. The amount of water applied by a center pivot during one irrigation is determined by the irrigation pumping rate and the revolution time of the center pivot system. The minimum irrigation amount will be applied when the system is operated at the maximum rotation speed. Consult your system operator's manual for specific system information.

*Solid set*, *hand move*, and *side roll* lines are examples of stationary systems. These systems differ from self-propelled types in that they are set

on a given area of the field and do not move during irrigation. The greatest limitation with stationary systems is distortion of the water distribution by wind. Chemicals should not be applied through these systems if wind causes the spray to drift to nontarget areas.

*Traveling gun* systems may be acceptable for chemigating when operated in low wind conditions. In general, characteristically poor application uniformity and susceptibility to wind drift limits their suitability for chemigating.

## *Surface Systems*

Surface or gravity flow (furrow and flood) irrigation systems have limited potential for chemigation since they cannot be used for foliar applications. Surface systems generally provide poor uniformity of distribution since they may not sufficiently wet the soil on ridge tops of hill or bed-planted crops. This may be important if uniform distribution of a herbicide is needed.

Forming the furrow or bed is important because it influences the rate of water flow, the amount of water applied, and uniformity. Furrow slicking or packing devices and bed forming machines produce a smooth, firm, clod-free surface that helps control the water application during the first irrigation.

A water application of 2 to 2.5 inches is the practical minimum for the first irrigation with most furrow or flood systems. A reuse pit to collect tailwater is a requirement when using a surface irrigation system for applying chemicals. Tailwater must be collected and reapplied on the same field or other crops for which the chemical is registered.

## *Drip or Trickle Systems*

Drip or trickle irrigation is frequent, slow application of water to soils through emitters or orifices located at selected points along water delivery lines. Most emitters are placed on the ground, but they can be buried or suspended above the ground. Emitters can be of many types. The "dripper" types usually deliver 1 to 2 gallons per hour. The "jet" types usually deliver more.

Fertilizers and herbicides that need to be applied to the soil surface and/or incorporated to a certain depth below the surface are commonly applied through drip irrigation systems. Relatively little data has been compiled on the effectiveness of applying pesticides in this manner.

Most drip systems can apply water to only a portion of the soil surface. The typical drip system applies water at the soil surface although some are installed below the soil surface. Thus, drip systems are not suitable for broadcast or foliar applications.

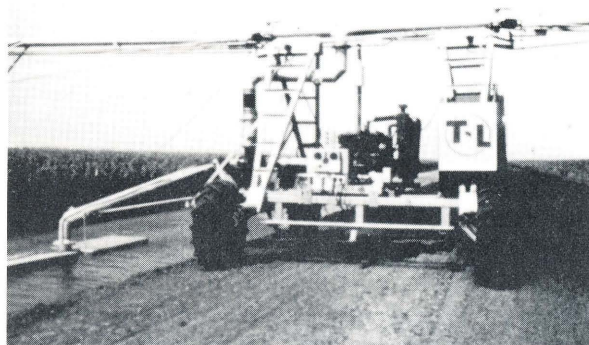

Because they uniformly distribute both water and chemicals, sprinkler irrigation systems are best suited for chemigation.

## EQUIPMENT

Equipment required to apply chemicals through an irrigation system includes:

- a chemical supply tank with agitator
- an injection pump
- a calibration tube
- proper safety and antipollution devices to prevent potential contamination of the water source

### *Supply Tank*

The tank should be constructed of noncorrosive materials such as stainless steel, fiberglass, nylon, or polyethylene. Iron, steel, copper, aluminum and brass should be avoided. Agitation in the chemical tank is required when wettable powders, dry flowables, flowables, tank mixes or any other suspended formulations are used. Hydraulic agitation may be sufficient for some soluble chemicals, while mechanical agitation may be necessary for other types of chemicals. Refer to labels for specific instructions.

Some agricultural chemicals may be flammable. In such cases, explosion-proof electric motors and wiring must be used, a separation distance maintained, or the chemical diluted. Wiring must conform with all requirements specified in the National Electrical Code for hazardous area applications. Check chemical labels for specific requirements.

### *Injection Pump*

The chemical injection pump is the heart of



Trailer mounted chemical tank permits use at multiple injection sites.



Low maintenance and ease of adjustment are among advantages of diaphragm pump.

any chemigation system. Within the minimum to maximum pump operating range, a delivery accuracy of plus or minus one percent is desirable. The pump should be easily adjusted for different injection rates and mechanically rugged with the internal and external components being of acceptable noncorrosive materials. A variety of injection pumps is available. The main types, based on operating principle, are:

- diaphragm
- piston
- venturi (vacuum)

The injection pump capacity should be consistent with application rates of the chemicals that will be applied by chemigation. Chemical application rates can range from 1 pt/acre for some insecticides to more than 30 gal/acre for liquid fertilizer solutions. Consequently, pump injection rates may need to range from as low as 2 gal/hr to more than 400 gal/hr. No single pump can do all jobs. Most pumps are graduated in units or percentages which represent the amount of liquid pumped at a particular setting. However, these settings may be less than exact. Avoid operating a pump at its maximum output or near its minimum output. Such usage can damage the pump and/or result in inaccurate pumping rates. Piston pumps in particular lose suction capabilities proportionally as stroke length of the piston is reduced for pumping smaller amounts. It is most efficient and consistent to operate within the broad middle capacities of each pump.

## ANTI-POLLUTION PROTECTION

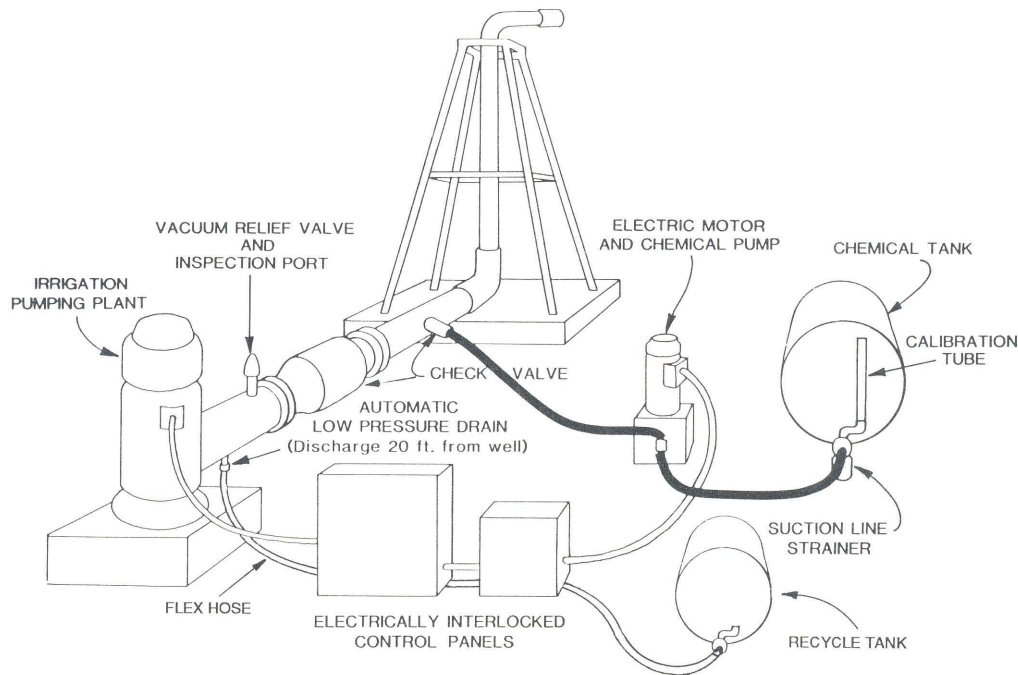

A properly equipped chemigation system includes the equipment and antipollution and safety devices depicted in this diagram.

*Diaphragm pumps* — Diaphragm pumps have been used in the chemical industry for many years but have only been actively marketed for chemigation during the last few years. Although most diaphragm pumps are more expensive than piston or venturi units, they have several distinct advantages over other injection units.

- They have a small number of moving components.
- A very limited area of the components is exposed to the chemical being injected. This greatly reduces the potential for corrosion, wear and leakage compared to piston pumps. Consequently, this greatly reduces potential maintenance costs and the potential for the human and environmental safety risks caused by leaks.
- The design of diaphragm pumps makes it easy to adjust the injection rate while the pump is operating. For most of these pumps, the injection rate is changed by simply turning a micrometer-type adjustment knob.

In general, diaphragm types are the best all-around pumps to use for injecting chemicals through irrigation systems.

*Piston pumps* — The earliest available and actively marketed injection equipment for agricultural chemicals were piston pumps. Both single and dual piston units are available in a wide range of capacities. These types of pumps commonly have two distinct disadvantages for chemigation:

- Piston pumps are subject to accelerated wear of piston seals. Related to this is potential for increased human and environmental safety risks from resultant leakage and increased maintenance costs.
- Calibration of most piston pumps is relatively time consuming. Altering the injection rate requires that the pump be stopped and the stroke length adjusted mechanically. The pump is then restarted and the injection rate checked. Several repetitions of this cycle normally are needed to accurately calibrate a pis-



ton pump. Some newer piston type pumps can be adjusted while operating.

Piston pumps are most commonly used to apply fertilizers where relatively high injection rates are needed.

*Venturi units* — Venturi chemical injection units or “pumps” operate by generating a differential pressure or vacuum across a venturi device. This draws the chemical into the irrigation system. The differential pressure is controlled by either:

- a pressure-reducing valve installed in the main line of the irrigation system in parallel with the venturi injection device; or
- a small auxiliary pump (i.e. centrifugal) installed in series with the venturi device with both the auxiliary pump and the venturi device connected in parallel with the irrigation system mainline.

The primary advantage of venturi injection units is their relatively low cost. A major disadvantage of venturi units is the dependence of chemical injection rate upon the available differential pressure. Since the rate of chemical injection is directly dependent upon the differential pressure, any variation in the differential pressure from the calibrated pressure will significantly alter the rate of chemical injection. Variation in flow rate can cause the pressure to vary. Thus, obtaining accurate and consistent

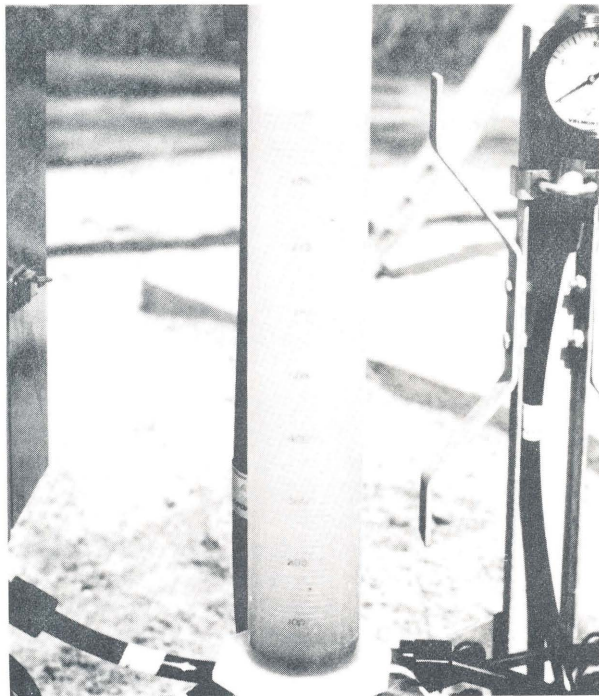

A calibration tube is essential for measuring output of injection system.



Removable vacuum relief valve serves as a port to inspection check valve.

rates of chemical injection with a venturi device may be difficult.

#### *Calibration Tube*

A calibration tube should be located in the line between the supply tank and the chemical injection pump. It is used to measure output of the injection unit during calibration process. It should be clear, resistant to breakage, and graduated in units of volume (pints, ounces, milliliters, etc.). To properly calibrate an injection system, it is necessary to monitor chemical injection at least five minutes. Therefore, calibration tubes must be large enough to hold enough chemical to be injected over that time.

#### *Antipollution/Safety Devices*

**Irrigation line check valve and vacuum relief valve** — Check and vacuum relief valves (back-flow prevention devices) are required in irrigation pipelines. They keep the chemical-water mixture from draining or siphoning back into the water supply. Both of these valves are to be located between the irrigation pump discharge and the location at which the chemical is injected into the irrigation pipeline. The vacuum relief valve is normally placed between the check valve and the irrigation pump discharge into the irrigation pipeline.

The check valve must have a positive closing action and water-tight seal, and be easy to repair

and maintain. It should be installed with fittings that allow for easy removal for maintenance and repair. The vacuum relief valve allows air into the pipeline when the water flow stops, preventing a vacuum that could cause siphoning. It is important to inspect these valves before each chemigation operation. Be sure that the back-flow prevention device used meets the requirements of the applicable regulatory agencies.

**Inspection port** — An inspection port should be located between the irrigation pump and the mainline check valve to permit visual inspection of the check valve for leaks. This inspection should be made before each chemigation operation. In many cases, the vacuum relief valve connection can serve as the inspection port.

**Low pressure drain** — An automatic low pressure drain should be placed on the bottom side and lowest point of the irrigation pipeline. The preferred location of this drain is between the irrigation pump and the mainline check valve. If this location is not accessible, this valve must, in all instances, be located on the irrigation pipeline before the point of chemical injection. The flow from the drain should be discharged at least 20 feet from the water source using a hose or pipe. Water from the hose or pipe should not be allowed to pool or flow toward the water source. In the event that the mainline check valve leaks slowly, this drain will ensure that the solution will drain away from, rather than into, the well or other water source.

**One-way interlocking** — A one-way interlock must be installed between the irrigation pump and chemical injection pump to ensure that if the irrigation pump stops, the chemical injection pump also will stop. This prevents pumping chemical from the supply tank into the irrigation pipeline after water stops flowing.

On systems with an engine-driven irrigation pump, the chemical injection pump can be belted to the drive shaft or an accessory pulley of the engine. Other alternatives include operating the injection equipment from the engine electrical system (12 v), or an electrical generator driven by the pumping plant power unit. These types of installations are directly interlocked so that the injection device operates only when the irrigation pumping plant is operating.

On systems with an electric motor-driven irrigation pump, a separate, small electric motor is usually needed to power the chemical injection pump. The electrical controls for the two

electric motors must be interlocked so both motors will stop when the electric motor on the irrigation pump stops. All wiring should conform to the National Electric Code.

In addition, it is recommended that an interlock also be provided to shut off the irrigation system and pumping plant if the injection unit stops or malfunctions. This allows the operator to know where chemical application stops if the chemical injection unit stops. The interlock can be done electrically or with the use of a flow sensor on the discharge side of the chemical injection device. When there is no flow in the injection line, the irrigation system or pumping plant would be shut down.

**Chemical injection line check valve** — A check valve in the chemical injection line is necessary to stop the flow of water from the irrigation system into the chemical supply tank. If this check valve were omitted and the injection pump stopped, irrigation water could flow back through the chemical line into the chemical supply tank, overflowing the tank and causing a spill around the irrigation well. This check valve should have a minimum opening (cracking) pressure of 10 psi and be constructed of chemically resistant materials. With the 10 psi minimum opening pressure, this check valve should also prevent gravity flow from the chemical supply tank into the irrigation pipeline after an unexpected shutdown.

**Solenoid valve** — A normally closed solenoid

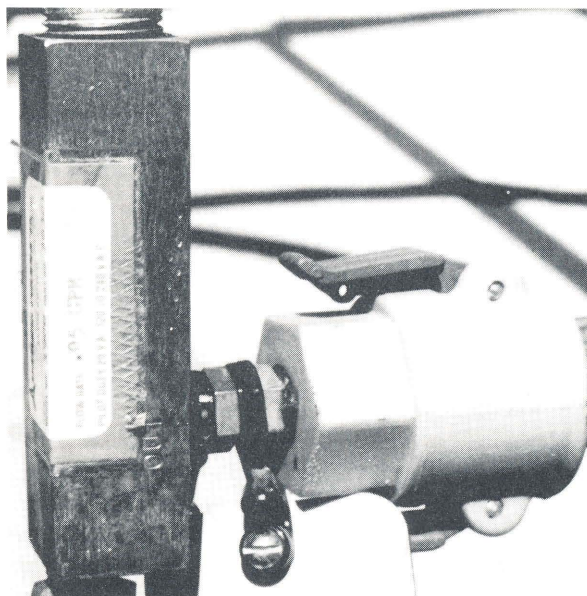

A flow sensor on the chemical injection line can shut down the irrigation system and pumping plant if chemical flow stops.

valve can be electrically interlocked with the engine or motor driving the injector pump. This valve, located on the inlet side of the injection pump, provides a positive shutoff of chemical flow in the injection line. The chemical cannot flow if the chemical pump is stopped and the valve closes. Since this valve will be subjected to concentrated chemical, it must be compatible with the chemicals being injected. The valve should be inspected often to assure that it is performing satisfactorily.

Because of the relatively limited use of normally-closed solenoid valves on agricultural chemical injection systems, they may not be readily available.

**Chemical suction line strainer** — A strainer on the inlet end of the chemical suction line is necessary to prevent clogging of the injection pump, check valve, or other equipment. The mesh size of this strainer will be dependent on the type of chemical being injected. For most chemicals, a 50-mesh screen will be used.

**Fresh water faucet** — It also is recommended that a fresh water faucet be installed between

the irrigation well pump outlet and the mainline check valve. If for any reason this is not possible, the faucet should be installed *upstream* from the chemical injection point. The faucet is intended solely as a source of water for cleanup and rinsing empty chemical containers. It should *never* be used as a port for injecting any agricultural chemical, nor should it be used as a source of drinking water during the chemigation process.

All equipment and accessories, including hoses, seals, gaskets, etc., that come in contact with chemical mixtures must be resistant to all formulations of agricultural chemicals being applied, including emulsifiers, solvents, and other carriers in addition to the active ingredient.

The equipment described above will, in most cases, provide an acceptable level of protection against contamination of the irrigation water source. In cases where the irrigation water source is a potable water supply system, different antipollution protection equipment may be required. Many states have adopted specific regulations and specifications for antipollution equipment. Check with the appropriate regulatory agency for specific requirements.

## CALIBRATION PROCEDURES

Equipment calibration is extremely important in chemigation. Until you calibrate, it is impossible to determine the amount of chemical being applied. Apply too little, and you may not achieve the desired results; apply too much, and you waste money and potentially damage the crop and environment. The objective is to apply the desired amount of chemical; i.e. equal to or less than the amount specified on the product label.

Calibrating chemigation equipment is relatively simple, but requires time, equipment and accurate calculations. Always calibrate the irrigation system and injection pump yourself rather than relying on data furnished by the manufacturer. The manufacturer's suggestions can eliminate the need for much trial and error, but you still need to determine the exact irrigation water output and injection pump setting. This is because conditions at your worksite will not be the same as at the factory.

### *Measuring Equipment*

Measuring equipment includes: a stop watch, a steel measuring tape (preferably at least 100 ft), a pocket calculator, and marking or plot flags large enough to be seen easily at a distance.

### *Calibration Equipment*

Specific calibration equipment includes a clear cylinder, graduated in units of volume. This is necessary to measure the output of the injection

pump. In order to properly calibrate and monitor the application process, the cylinder, or calibration tube, should be clear, resistant to breakage, and large enough to hold a volume sufficient for a minimum of 5 minutes injection. The calibration tube is located in line between the injection pump and the supply tank.

Although not nearly as accurate as a calibration tube, a pressure relief/regulating valve also can be used for calibration. This valve can be used for "rough" calibrations of pump output by installing it on the end of the injection/measuring pump output hose, setting the pressure equal to the irrigation line pressure at the point of injection and directing the output volume into a measuring can for a specific time period. This method is superior to open discharge pumping into a catch basin because pressure is maintained against the pump.

Calibration involves five basic steps:

1. determine the area in acres to be irrigated
2. determine the amount of material desired per acre
3. determine the total amount of material required (step 1 x step 2)
4. determine the time (in hours) that injection will take place
5. determine the injection rate in gallons per hour (step 3 ÷ step 4)

The injection equipment and safety devices required for applying chemicals through all types of irrigation systems are similar, as are the calibrating procedures.

### *Calibrating the Center Pivot Irrigation/Chemigation System*

The calibration process is based on the given measurements of the irrigation system (length, end gun wetting area, etc.), some common mathematical constants and conversions, and the desired rate of chemical injection. The following calculations must be made: A) area irrigated, B) amount of chemical required, C) travel speed, D) revolution time, and E) chemical application rate. The following example will illustrate the procedure.

#### *A) Area irrigated:*

The area irrigated must be calculated with one of several possible formulas. The degree of difficulty in making this calculation depends on the configuration of the field. The simplest case would be a complete cir-

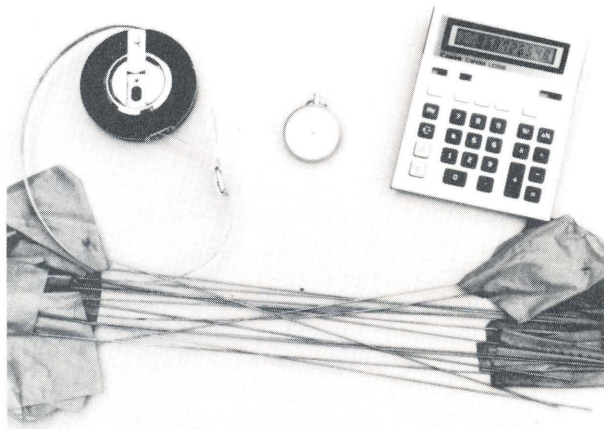

Tape, stopwatch, calculator and flags are needed in the calibration process.

cle without intermittent end guns or corner watering systems. The calculation is:

$$\text{Area of the circle in acres} = \frac{\pi \times r^2}{43,560 \text{ sq. ft. per acre}}$$

where  $r$  = the wetted radius (length of pivot plus effective throw of end gun) and  $\pi = 3.1416$ .

Assume  $r = 1300$  ft.:

$$\text{Area} = \frac{3.1416 \times (1300 \times 1300)}{43,560} = 122 \text{ acres}$$

The area irrigated becomes increasingly more complex with partial circles, circles with intermittent end guns and other configurations. Calculations determining the area of some irregular field configurations appear in Appendix A. In many situations, it may be wise to leave the end gun off because the water pattern is easily distorted by wind. If an end gun shut off fails, it may result in an off-target application.

B) *Amount of chemical required:*

$$\text{Chemical Required} = \text{Acres irrigated} \times \text{chemical application rate}$$

Assume 1 qt. chemical is required/acre:

$$122 \text{ acres} \times 1 \text{ qt. chemical/acre} = 122 \text{ qts. (30.5 gallons) needed to treat the entire field.}$$

C) *Travel speed:*

For moving systems, travel speed is one of the most important measurements. When calculating the irrigation system speed, the system should be running "wet" and at the speed and pressure that will be used while chemigating. Always recalibrate when changing speed settings. Avoid determining pivot speed at one percentage setting and mathematically calculating the pivot speeds for other settings, other than to obtain a "rough" figure. Using a stop watch, the proportion of one minute that the end tower is actually moving can be checked against the percentage timer in the pivot control panel.

Two measurements, **time** and **distance**, are required to calculate the rotational speed of the pivot. They can be taken in several ways:

1) record the time necessary for the outer

pivot tower to travel a premeasured distance (usually a minimum of 50 ft.)

2) measure the distance traveled by the outer pivot tower in a preselected time (usually a minimum of 10 minutes).

The end result of either method is rotational speed in ft/minute. Be aware that a measurement error of only a few feet or a few minutes can create a significant error in the entire calibration process. If the percentage timer is set at less than 100% when determining pivot speed, make sure the start and stop measurements are taken at the same points in the move/stop cycle. (This is not a concern with some oil hydraulic pivots where the end tower moves continuously.) If the terrain is rolling, check rotational speed at several locations in the field and calculate the average value. It may also be wise to verify rotational speed several times throughout the season to account for differences in wheel track resistances due to cover, soil compaction, track depth, etc.

Assume the measured distance per 10 minutes = 65 ft.

$$\text{Travel speed} = \frac{65 \text{ ft}}{10 \text{ min}} = 6.5 \text{ ft/min}$$

D) *Revolution time:*

Circumference of the last wheel track and rotational speed of pivot are the two measurements needed to calculate revolution time. Circumference is calculated by the formula:

$$\text{Circumference} = 2 \times \pi \times r$$

Where  $r$  = the distance in feet from the pivot point to outer wheel track and  
Where  $\pi = 3.1416$ .

Assume  $r = 1280$  ft

$$\text{Circumference} = 2 \times 3.1416 \times 1280 = 8042 \text{ ft}$$

Even though the owner's manual accompanying the irrigation system might list the system length, the length required for this calculation is from the pivot point to last wheel track (it does not include the overhang). It is a good idea to correctly measure this distance once and permanently record it in the control panel.

Revolution time is calculated by dividing the circumference in feet by rate of travel in feet per minute.

$$\text{Revolution time} = \frac{\text{circumference (feet)}}{\text{Travel Speed (ft/min)}}$$

Then:

$$\begin{aligned} \text{Revolution time} &= \frac{8042 \text{ ft.}}{6.5 \text{ ft/min}} \\ &= 1237 \text{ min. per rev.} \end{aligned}$$

To convert the revolution time to hours, divide the above answer by 60.

EXAMPLE:

$$\frac{1237 \text{ min}}{60 \text{ min/hr}} = 20.6 \text{ hours per revolution}$$

E) *Chemical application rate:*

The application rate is the amount of formulated material needed to treat the field (Step B) divided by the revolution time in hours (Step D).

$$\begin{aligned} \text{Chemical application rate} \\ \text{[gallons per hour (gph)]} &= \\ \frac{\text{total material needed (gallons)}}{\text{hrs/revolution}} \end{aligned}$$

EXAMPLE:

$$\begin{aligned} \text{Chemical application rate} &= \frac{30.5 \text{ gal}}{20.6 \text{ hrs}} \\ &= 1.48 \text{ gph} \end{aligned}$$

Determining these amounts in gph is necessary because most commercially available pumps are rated in gph. Knowing the injection pump capacity in relation to the delivery rate needed can help you establish an initial pump setting. However, be aware that book output values of pumps are normally measured at the factory based on a drive shaft speed of 1725 rpm. Any variance in this shaft speed will alter the pump output. When the injection pump is belt driven from the engine drive shaft, a tachometer is helpful. Pump wear will also alter output. Fine tuning should be accomplished using a calibration tube placed on the suction side of the injection pump. Chemicals vary in viscosity and density. Always make the final calibration with the material to be injected and at the operational pressure of the irrigation system. If the volume is small, as with an insecticide,

and the calibration tube is measured in milliliters or ounces, **gph can be converted to milliliters/minute by multiplying gph x 63.07 or can be converted to ounces/minute by multiplying gph x 2.133.**

1. If calibration tube is in milliliters,  $1.48 \text{ gph} \times 63.07 = 93 \text{ ml/minute}$ .

2. If calibration tube is in ounces,  $1.48 \text{ gph} \times 2.133 = 3 \text{ ozs/minute}$ .

This amount of chemical, in ml/min or ozs/min, is the working factor to calibrate the injection pump. Using the calibration tube, make coarse adjustments on one minute time checks. Make a final check over an extended time period (at least 5 minutes).

For an initial injection pump setting, the desired injection rate is divided by the pump capacity to give a percent setting.

EXAMPLE:

Required injection rate is 1.48 gph and pump is rated at 4 gph max.

$$\begin{aligned} \text{Injection rate, \% of capacity} &= \\ \frac{1.48 \text{ gph}}{4.00 \text{ gph}} \times 100 &= 37\% \end{aligned}$$

Thus 37% is the suggested first setting for the initial calibration attempt.

#### *Calibrating a Stationary Sprinkler System*

Solid set, hand lines, and wheel lines are examples of stationary irrigation systems that can be used for applying agricultural chemicals.

An advantage of the stationary system is being able to inject the chemical anytime during the irrigation process. A herbicide may be injected midway through the irrigation process to allow additional water to be applied for incorporation. A foliar insecticide, in contrast, will usually be applied near the end of the irrigation to limit the amount of water that is applied following the insecticide application to reduce wash off.

The following is one way to calibrate a stationary sprinkler system.

1. Determine the acres to be irrigated in one set. Multiply the lateral spacing along the main line by the length of the lateral and divide by 43,560 (square feet per acre). If more than one lateral is being operated simultaneously, also multiply by the number of laterals.

EXAMPLE:

10 laterals 800 feet long spaced 40 feet apart

$$\begin{aligned} \text{Area irrigated} &= \\ \frac{800 \times 40 \times 10}{43,560} &= 7.3 \text{ acres} \end{aligned}$$

- Determine the amount of formulated chemical needed per acre (consult product label).

EXAMPLE:

4 pounds of wettable powder herbicide per acre

- Determine the total amount of chemical needed (Step 1  $\times$  Step 2).

EXAMPLE:

Total chemicals = 7.3 acres  $\times$  4 pounds per acre = 29.2 pounds

- Determine the amount of water to be applied during the application. Follow recommendations on chemical product label.

EXAMPLE:

Herbicide label recommends that 1.0 acre-inch of water be applied and that the herbicide be injected during the first half of the irrigation period

- Determine the rate of water application by the irrigation system. Attach a short piece of hose to the nozzle outlet(s) of one sprinkler, start the irrigation system, and measure flow for 1 minute. Repeat this procedure at several sprinklers along the lateral and determine the average sprinkler flow rate. Given the sprinkler flow rate in gallons per minute and the sprinkler spacing, the water application rate in inches per hour can be determined from application rate tables or with the following equation:

$$\begin{aligned} \text{Water application rate, inches/hour} &= \\ \frac{96.3 \times \text{gpm}}{S_l \times S_m} \end{aligned}$$

where: gpm = discharge from sprinkler, gallons per minute

$S_l$  = spacing of sprinklers on lateral, feet

$S_m$  = spacing of lateral on main, feet

EXAMPLE:

sprinkler flow = 4 gallons per minute  
sprinkler spacing = 40 ft  $\times$  40 ft

$$\begin{aligned} \text{water application rate, inches/hour} &= \\ \frac{96.3 \times 4 \text{ gpm}}{40 \text{ ft} \times 40 \text{ ft}} &= 0.24 \text{ in/hr} \end{aligned}$$

Another method to determine water application rate is to determine the sprinkler nozzle(s) size (usually stamped on the nozzle) and discharge pressure, then consult the sprinkler manufacturer's application rate table. Adjust the length (time) of the irrigation to apply the amount of water necessary for proper chemical application.

- Determine time to irrigate. Divide the gross amount of water to be applied by the rate of water application (Step 5).

**Gross irrigation amount =**

$$\frac{\text{Net irrigation amount}}{\text{Irrigation application efficiency}}$$

**Irrigation time =**

$$\frac{\text{Gross irrigation amount}}{\text{Water application rate}}$$

EXAMPLE:

Irrigation application efficiency = 80% (assumed)

Net irrigation = 1.0 in

Gross irrigation amount =

$$\frac{1.0 \text{ in}}{0.8} = 1.25 \text{ in}$$

Irrigation time =

$$\frac{1.25 \text{ in}}{0.24 \text{ in/hr}} = 5.2 \text{ hours}$$

- Fill the solution tank with the chemical to be applied or chemical-water solution. Start the tank agitator if needed.

EXAMPLE:

Add 30 gallons of water (approximately 1 gallon water for each pound of wettable powder) to solution tank, start agitator, and add 29.2 pounds of formulated herbicide. Add more water to bring total volume to 50 gallons.

- Determine the injection rate by dividing the total gallons in the tank (Step 7) by the time (hours) required to apply the chemical.

Assume that chemical will be applied for 2 hours during the mid portion of the irrigation time.

EXAMPLE:

$$\text{Injection rate} = \frac{50 \text{ gallons}}{2 \text{ hours}} = 25 \text{ gallons per hour}$$

- Calibrate the delivery rate of the injection pump to make certain the rate is correct.
- If chemical solution is to be applied throughout or during the last part of the irrigation, allow the irrigation system to operate for sufficient time after the injection to completely flush the chemical from the system. The time required will normally be a minimum of five minutes and may be as long as 15 to 20 minutes.

#### *Calibrating a Surface Irrigation System*

The following steps illustrate one method for making the calibration calculations for a surface irrigation system. A furrow irrigation system is used in the example.

- Determine the acres to be irrigated in one set.

EXAMPLE:

100 rows on 30-inch (2.5 feet) spacing that are 1,000 feet long

$$\text{Area irrigated} = \frac{100 \times 2.5 \times 1,000}{43,560} = 5.7 \text{ acres}$$

- Determine the amount of formulated herbicide needed per acre (consult product label).

EXAMPLE:

2 quarts of herbicide per acre

- Determine the total amount of herbicide needed (Step 1  $\times$  Step 2).

EXAMPLE:

$$\text{Total chemical} = 5.7 \text{ acres} \times 2 \text{ quarts per acre} = 11.4 \text{ quarts}$$

- Partially fill the solution tank with water, leaving room to add the herbicide. Start the agitator and add the herbicide to the tank.

EXAMPLE:

Add 25 gallons of water to the solution tank, start agitator, and add 11.4 quarts of herbicide. Add more water to bring total volume up to 40 gallons. Undiluted liquid herbicide also can be injected into an irrigation system.

- Determine the time required for the irrigation. This time will be dependent on the irrigation pumping rate and the characteristics of the field being irrigated.

Assume 4 hours will be required to apply 1.5 inches of water

- Determine the injection rate by dividing the total gallons in the tank (Step 4) by the number of hours required for irrigation (Step 5).

EXAMPLE:

$$\text{Injection rate} = \frac{40 \text{ gallons}}{4 \text{ hours}} = 10 \text{ gph}$$

- Calibrate the delivery rate of the injection pump to make certain the rate is correct. In some cases, a constant head siphoning device can be used instead of an injection pump to meter the herbicide into the water source.

#### *Calibrating a Drip or Trickle System*

To calculate the amount of chemical to apply per acre through a drip system, the lateral movement of water from the emitter must be measured. But, because the pattern of water movement is often irregular, it is difficult to calculate the area irrigated.

A more workable method is to apply solutions of a known chemical concentration for a definite period of time. The amount of chemical in solution is expressed in parts per million (ppm). For deep rooted perennial crops, for example, herbicide solutions of 20 to 100 ppm applied for 2 to 4 hours have controlled weeds selectively. For selective weed control in annual row crops, concentrations usually are lower.

To calibrate a drip irrigation system and injection pump (assume that a 20 ppm solution applied for 4 hours will be needed to control weeds), do the following:

- Determine how many gallons of water are



being delivered per hour per acre by the drip system. Collect the water from 10 randomly selected emitters for a given period. If a short time period is used, accurate volume measurements must be made since the amount of water will be small. Calculate the average flow per emitter and convert to the flow rate per hour per emitter. The amount of water delivered per acre can then be calculated by multiplying the number of emitters/acre by the flow rate.

EXAMPLE:

Average flow for 10 randomly selected emitters was 2 ounces per minute. 2 ounces  $\times$  60 minutes = 120 ounces per hour or about 1 gallon per hour. If there are 1,000 emitters per acre and each emitter delivers 1 gallon per hour, the system delivers approximately 1,000 gallons per hour/acre.

2. Determine the weight of the water applied. Each gallon of water weighs 8.33 pounds. Multiply the number of gallons delivered per hour per acre by the drip system (Step 1) by the weight of one gallon of water (8.33 pounds).

EXAMPLE:

$$1,000 \text{ gal/hrs/acre} \times 8.33 \text{ lb/gal} \\ = 8,330 \text{ lb/hr/acre}$$

Multiply the weight of the water applied per hour by the number of hours the system runs.

EXAMPLE:

$$8,330 \text{ lb/hr/acre} \times 4 \text{ hrs} \\ = 33,320 \text{ lb/acre of water in 4 hr/acre}$$

3. Determine the pounds of active herbicide required. A 20 ppm solution equals 20 pounds of herbicide per 1,000,000 pounds of water. Multiply the ppm required by the total weight of the water applied during the irrigation period and then divide by 1,000,000.

EXAMPLE:

$$\frac{20 \times 33,320}{1,000,000} \\ = 0.66 \text{ pound of active herbicide per acre}$$

4. Determine the amount of formulated herbicide required.

EXAMPLE 1:

Herbicide is formulated as 2 pounds active ingredient per gallon.

$$\frac{0.66 \text{ pound}}{2 \text{ pounds/gallon}} = 0.33 \text{ (1/3) gallon per acre}$$

EXAMPLE 2:

Herbicide is formulated as a 50% wettable powder.

$$\frac{0.66 \text{ pound}}{0.50} = 1.32 \text{ pounds per 4 hours}$$

5. Partially fill the solution tank with water, leaving room to add the herbicide. Start the agitator and add the herbicide to the tank.

EXAMPLE:

Add 15 gallons of water, start agitator, and then add 1/3 gallon (from example 1 in step 4) of herbicide per acre irrigated at one time. Add more water to bring total volume to 20 gallons.

6. Determine injection rate by dividing the total gallons of solution in the tank (Step 5) by the hours the drip system runs.

EXAMPLE:

$$\frac{20 \text{ gallons}}{4 \text{ hours}} = 5 \text{ gallons per hour}$$

7. Calibrate the delivery rate of the injection pump to make certain the rate is correct. If the herbicide moves rapidly in the soil, it is desirable to inject it during the last 4 hours of irrigation. If the herbicide does not move readily in the soil, it should be injected earlier in the irrigation.
8. Allow the irrigation system to operate for a sufficient time after the injection is finished to completely flush the herbicide from the system. The time required will normally be a minimum of 15 minutes and may be as long as 30 minutes.

## MANAGEMENT

All irrigation and injection equipment must be kept in good working order. In addition, instructions on chemical labels must be followed precisely. Most chemical accidents result from careless practices or lack of knowledge about safe handling of chemicals. Time spent taking precautionary safety measures is an investment in the health and safety of yourself, your family and others, and in protecting the environment. It also helps assure that desired results are achieved.

### *Equipment Maintenance and Inspection*

Proper equipment maintenance is necessary to ensure safe distribution of chemicals. Consequently all hoses, clamps and fittings must be in good repair. Inspect them before each chemigation operation. All components that are in contact with chemicals, from the supply tank to the point of injection on the irrigation pipeline, should be constructed of chemically resistant materials.

Periodically monitor the irrigation system and chemical injection equipment to assure proper operation. Before chemigating, inspect your equipment to be certain that the following items are functioning properly:

- the irrigation system main pipeline check valve and vacuum relief valve
- the chemical injection line check valve
- the irrigation system and pumping plant main control panel and the chemical injection pump safety interlock
- the low pressure drain
- the injection system including the in-line strainer
- the irrigation pump and power source

### *Read and Comply With Product Label*

If you plan to apply a pesticide, *always* read the product label before starting to chemigate and comply with all directions given. Be certain that:

- the product is labelled for application by chemigation;
- the crop on which you plan to apply the pesticide is listed on the label;
- the rate at which the product is applied does

not exceed the quantities or frequency specified;

- all items of safety clothing and equipment specified are used;
- empty pesticide containers are triple rinsed and disposed of as directed.

### *Monitoring*

During any chemical application, periodically monitor the irrigation system and chemical injection equipment to be certain that both are operating properly.

### *Plug First Nozzles on Center Pivots*

To facilitate monitoring of the chemigation operation, the main control panel, water pump, chemical supply tank, chemical injection pump and the area around them must be kept free of chemical contamination. Plugging the nozzle outlets in the immediate area of this equipment will significantly reduce the possibility of inadvertent exposure to chemical contamination.

### *Accidental Spills*

In case of a chemical spill, regardless of size, 1) avoid personal contamination; 2) take action to keep potential spill damage to a minimum.

Keep persons — particularly children — away from spills. Avoid getting the chemical (especially if it is a pesticide) on your skin, clothing or shoes.

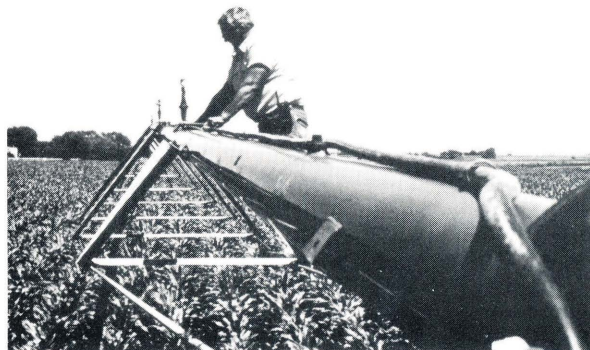

Plugging nozzles adjacent to pivot point helps reduce possible chemical exposure.

Confine the spill if possible. If it starts to spread, dike it with soil or sand. Avoid letting chemical flow away from the spill site into any surface water source. Special precautions, such as removing the contaminated soil may be necessary to prevent ground water contamination.

Laws in some areas require that regulatory officials be notified in the event of a spill. If water contamination is suspected, notify state health and water quality officials. These officials may have suggestions and/or requirements for assisting in cleaning up a spill.

#### *Nontarget Application*

End gun shutoffs that fail to function and unfavorable weather conditions are among the common sources of nontarget or off-target applications. End gun operations must be monitored to be certain that they do not operate over roadways or across fence lines.

Spray from continuous move irrigation systems can be carried considerable distances by wind. Drift can result in violations of the law for misapplication of a pesticide and illegal pesticide residues in or on a crop. It also can damage your own nontarget crops or a neighbor's.

Wind variation also can have a detrimental effect on semi-permanent sprinkler systems such as wheel lines, hand lines, and solid set lines. To minimize problems associated with wind drift, these steps can be taken:

- avoid use when winds are great enough to cause significant drift
- space the sprinklers and lines more closely together, if possible
- operate at night when winds are relatively calm

#### *Application to Surface Water*

Do not use chemigation on fields with permanent or semi-permanent surface water areas. Such application may adversely affect wildlife, non-target plants and animals, or ground water quality.

#### *Runoff — Deep Percolation*

The irrigation system should be managed so that runoff or deep percolation of the water-chemical mixture does not occur. If runoff does occur within the field, precautions should be taken to prevent runoff from leaving the field when chemical is being applied. With a given sprinkler package on a center pivot, reducing

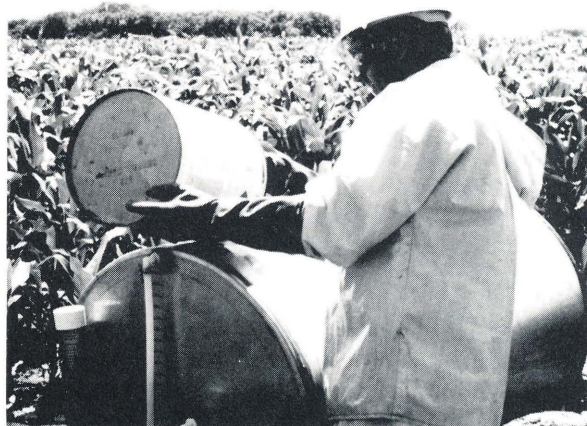

Wearing prescribed safety clothing and equipment reduces accident potential.

the application size by making a faster revolution will reduce the potential for runoff and deep percolation. Good irrigation management practices must be used throughout the entire irrigation season to avoid movement of water below the crop root zone and the potential for chemical leaching.

#### *Flushing Injection Equipment*

To prevent accumulation of precipitates in the injection equipment, flush the injection system with clean water after use. It is best to flush the injection system while the irrigation system is operating so that the water used for cleaning will be applied to the field where the chemigation application was made.

#### *Flushing Irrigation System*

After injection is completed, operate the irrigation pump for at least 10 minutes to flush the irrigation system of any chemical. Some systems, especially drip systems, may take longer than 10 minutes to completely flush. If the irrigation system was shut down automatically, flush the system as quickly as possible after the shutdown is discovered, and extend the flushing period to a minimum of 30 minutes.

#### *Protective Clothing and Equipment*

Because of the toxicity of many agricultural chemicals, pesticides in particular, they are potentially dangerous to people. Pesticide product labels have "signal" words that clearly indicate the degree of toxicity — and the degree of risk to the user — associated with that product. Pesticides labeled CAUTION are slightly toxic; an

ounce to more than a pint, if taken orally, would kill the average human adult. Those labeled WARNING are moderately toxic; a teaspoonful to a tablespoonful would be fatal to the average adult. Pesticides labeled DANGER include the skull and crossbones symbol and are highly toxic; a teaspoonful or less would be fatal.

There are three ways that chemicals can enter the human body:

1. through the mouth (orally)
2. by absorption through the skin (dermally)
3. by breathing into the lungs (inhalation)

Along with the signal words, pesticide product labels also include "route of entry statements" and statements of specific actions a user must take to avoid exposure.

The route of entry statements indicate the outcome from product exposure. For example, a pesticide label might read, "Poisonous if swallowed, inhaled, or absorbed through the skin. Rapidly absorbed through the skin and eyes." This tells the user that this pesticide is a potential hazard through all three routes of entry, and that skin and eye contact are particularly hazardous.

The specific action statements normally follow the route of entry statements and indicate what must be done to prevent poisoning accidents. In the case of the pesticide mentioned above, the statement might read, "Do not get in eyes, on skin, or on clothing. Do not breathe spray mist."

Regardless of their relative toxicity, all pesticides should be used carefully. Before handling, mixing, loading, or applying any pesticide, read label directions thoroughly. If the label calls for use of protective clothing or equipment or both, comply fully with those directions.

The type of protective clothing and equipment needed depends on both the toxicity of the pesticide and the type of formulation. Some labels state that specific items of clothing, equipment, and footwear must be used. In such instances, the applicator is legally responsible for using the listed safety apparel. Others carry no statement at all. In general, the more toxic the pesticide, the greater the need to use protective clothing and/or equipment.

When a pesticide label does not give specific instructions regarding proper protective clothing, wear at least a long-sleeved shirt and long-legged trousers, or coveralls that fully cover your

arms and legs. Disposable coveralls are available that provide adequate protection.

Shoes and socks also should be worn. Avoid sandals, thongs, and cloth or canvas shoes. Leather shoes are suitable with most pesticides. However, since leather absorbs liquids, rubber boots should be worn while working with highly toxic pesticides (signal word DANGER), and when there will be prolonged exposure to any pesticide spray.

When mixing and loading concentrates, especially those that are highly toxic, you should also wear a neoprene liquid proof apron.

Protection for your head is also advisable and in some cases is specifically required. In general, a wide brimmed, easily cleaned hat that will keep pesticides away from the neck, eyes, mouth and face is adequate. Avoid hats with cloth or leather sweat bands as these will absorb pesticides. Labels that specify use of headgear are usually found on highly toxic liquid concentrates. Wear a waterproof hood or plastic hardhat with a plastic sweatband when working with these pesticides.

Pesticides can cause eye damage and are readily absorbed through the eyes. Precautionary statements on liquid pesticide labels having the signal words WARNING and DANGER generally specify that eye protection be used. Use goggles or a face shield whenever such a statement is found on the label.

Gloves are also needed for handling pesticides. Unlined, liquid-proof neoprene or rubber gloves with tops that extend well up on the forearm are best. Avoid lined gloves because the lining can absorb the chemicals and is hard to clean. In most cases, wear gloves under shirt sleeves to prevent pesticide from leaking into the glove.

#### *Reentering Treated Areas*

In general, fields that have been chemigated with pesticide should not be reentered until spray has dried. A specific waiting period may be specified on the container label of some products. In such cases, applicators have a legal obligation to prevent unauthorized entry into treated areas. To discourage such unauthorized entry, applicators may be required to post treated fields. The U.S. Environmental Protection Agency (EPA) may revise its label requirements to include more restrictive provisions on posting chemigated fields. In addition, some states have passed chemigation laws containing posting provisions that may be more rigid than those of EPA. Fail-

ure to properly post a chemigated field can result in prosecution of the applicator. Before chemigating, therefore, carefully read the product label and comply with posting requirements that may be specified. Check with the pesticide regulatory authority in your state to be certain that you are in compliance with applicable state laws and regulations.

#### *Drip/Trickle Procedures*

Since clogging is by far the most commonly encountered problem in drip irrigation, it is important that the chemicals applied do not clog the system. To avoid clogging, the following guidelines should be followed.

- The chemicals must be reasonably soluble.
- If more than one chemical is used in preparing a stock solution, they must not react with one another and form a precipitate (deposit).
- The chemicals must not be harmful to irrigation system components.
- The chemical injection point should be located upstream of the filter so that any precipitates or impurities will be removed. Since water sources and contents vary, it is recommended that a compatibility test be performed before injecting any chemical into a drip irrigation system.

# DETERMINE IRRIGATED ACREAGE

Formulas for calculating acreages in fields and segments are shown below:

1. Area of a square =  $L^2$   
 "L" is the length in feet of one side of the square.

if  $L = 2640'$

$$L^2 = 2600 \times 2640$$

$$\text{Area} = 6,969,600 \text{ sq. ft.}$$

$$\text{Acres} = \frac{6,969,600 \text{ ft}^2}{43,560 \text{ ft. sq.}} = 160 \text{ acres}$$

\*43,560 ft. sq.

\*One (1) Acre = 43,560 ft<sup>2</sup>

$$\text{Acres} = \frac{\text{ft.}^2}{43,560 \text{ ft. sq.}}$$

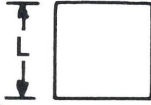

2. Area of a rectangular field. (A)

$$\text{Area} = L_1 \times L_2$$

$$\text{Area} = 2640' \times 5280$$

$$= 13,939,200$$

$$\text{Acres} = \frac{13,939,200 \text{ sq. ft.}}{43,560'} = 320 \text{ acres}$$

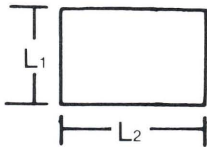

3. Area of a circle

$$\text{Area} = R^2 \times \pi$$

if  $R = 1300$

$$A = 1300^2 \times 3.14$$

$$= 5,309,291$$

$$\text{Acres} = \frac{5,309,291 \text{ sq. ft.}}{43,560 \text{ sq. ft.}} = 121.88 \text{ acres}$$

(  $\pi = 3.1416$  )

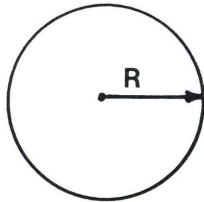

4. Area of a part circle

$$\text{Area} = (R^2 \times \pi) \times \frac{\alpha}{(360)^\circ}$$

if  $R = 1300$  &  $\alpha = 270^\circ$

$$\text{Area} = (1300^2 \times 3.14) \times \left(\frac{270^\circ}{360^\circ}\right)$$

$$= 3,981,968 \text{ ft}^2$$

$$\text{Acres} = \frac{3,981,968 \text{ ft}^2}{43,560 \text{ ft}^2} = 91.41 \text{ acres}$$

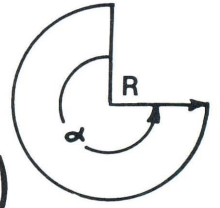

$\alpha$  = number of degrees, measured with a protractor

5. Area of a triangle

$$\text{Area} = \frac{H \times L}{2}$$

if  $H = 1300 \text{ ft.}$

&  $L = 1900 \text{ ft.}$

$$\text{Area} = \frac{(1300)(1900)}{2} = 1,235,000 \text{ ft}^2$$

$$\text{Acres} = \frac{1,235,000}{43560} = 28.4$$

$$= 1,235,000 \text{ ft}^2$$

"H" is the same as system length and is equal to the "radius"

"L" is length of the base in the triangle

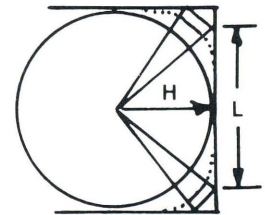

NOTE: To calculate (estimate) the **acreage** included in a very irregularly shaped area irrigated by a corner system, draw a straight line or a circular arc that will most nearly provide an "average" boundary.



On the following page you will find several typical examples incorporating the above segment formulas into whole field average calculations.

# STANDARD ELEC/WATER DRIVE

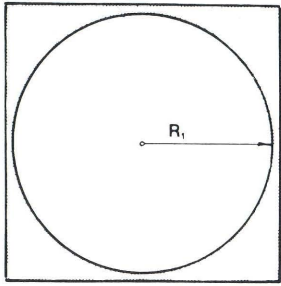

## FULL CIRCLE W/O E.G.

$$\begin{aligned} \text{Area} &= \frac{R^2 \pi}{43560} \\ &= \frac{1294 \times 1294 \times 3.1416}{43560} \\ &= 120.7 \text{ Acres} \end{aligned}$$

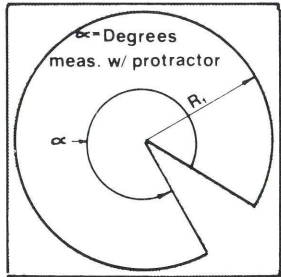

## PART CIRCLE W/O E.G.

$$\begin{aligned} \text{Area} &= \left( \frac{R^2 \pi}{43560} \right) \times \left( \frac{\alpha}{360} \right) \\ &= \frac{1294 \times 1294 \times 3.1416}{43560} \times \frac{330}{360} \\ &= 110.7 \text{ Acres} \end{aligned}$$

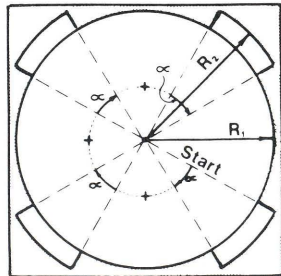

## FULL CIRCLE WITH E.G.

$$\begin{aligned} \text{Area} &= \left[ \left( \frac{R_1^2 \pi}{43560} \right) \times \left( \frac{360 - 4\alpha}{360} \right) \right] + 4x \left[ \left( \frac{R_2^2 \pi}{43560} \right) \times \left( \frac{\alpha}{360} \right) \right] \\ &= \left[ \frac{1294 \times 1294 \times 3.1416}{43560} \times \left( \frac{360 - 4 \times 30}{360} \right) \right] + \\ &\quad 4x \left[ \frac{1364 \times 1364 \times 3.1416}{43560} \times \frac{30}{360} \right] \\ &= 125.2 \text{ Acres} \end{aligned}$$

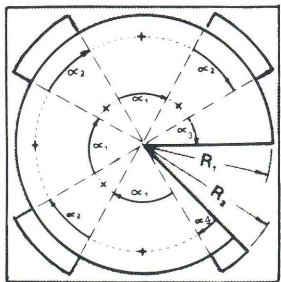

## PART CIRCLE WITH E.G.

$$\begin{aligned} \text{Area} &= 3x \left[ \left( \frac{R_1^2 \pi}{43560} \right) \times \left( \frac{\alpha_1}{360} \right) \right] + 3x \left[ \left( \frac{R_2^2 \pi}{43560} \right) \times \left( \frac{\alpha_2}{360} \right) \right] + \left[ \frac{R_1^2 \pi \alpha_3}{43560 \times 360} \right] + \left[ \frac{R_2^2 \pi \alpha_4}{43560 \times 360} \right] \\ &= 3x \left[ \frac{1294 \times 1294 \times 3.1416}{43560} \times \frac{60}{360} \right] + 3x \left[ \frac{1364 \times 1364 \times 3.1416}{43560} \times \frac{30}{360} \right] + \left[ \frac{1294 \times 1294 \times 3.1416}{43560} \times \frac{30}{360} \right] + \\ &\quad \left[ \frac{1364 \times 1364 \times 3.1416}{43560} \times \frac{15}{360} \right] \\ &= 109.58 \text{ Acres} \end{aligned}$$

# CORNER SYSTEMS

## FULL CIRCLE - 4 CORNERS

$$\begin{aligned} \text{Area} &= 4x \left[ \frac{\left( \frac{R_1 L}{2} \right)}{43560} \right] + 4x \left[ \frac{R_2^2 \pi}{43560} \times \frac{\alpha}{360} \right] \\ &= 4x \left[ \frac{\left( \frac{1268 \times 2100}{2} \right)}{43560} \right] + 4x \left[ \frac{1581 \times 1581 \times 3.1416}{43560} \times \frac{14}{360} \right] \\ &= 150.3 \text{ Acres} \end{aligned}$$

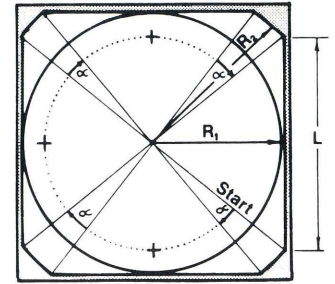

## PART CIRCLE

$$\begin{aligned} \text{Area} &= \left[ 2 \left( \frac{R_1 L_1}{2} \right) + \left( \frac{R_1 L_2}{2} \right) + \left( \frac{R_1 L_3}{2} \right) \right] + 3x \left[ \frac{R_2^2 \pi}{43560} \times \frac{\alpha}{360} \right] \\ &= \left[ 2 \left( \frac{1268 \times 2100}{2} \right) + \left( \frac{1268 \times 1800}{2} \right) + \left( \frac{1268 \times 1900}{2} \right) \right] + \\ &\quad 3x \left[ \frac{1581 \times 1581 \times 3.1416}{43560} \times \frac{16}{360} \right] \\ &= 139 \text{ Acres} \end{aligned}$$

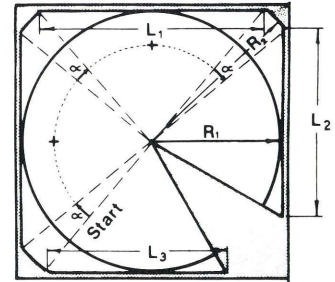

## RECTANGULAR FIELD

$$\begin{aligned} \text{Area} &= \left[ 2 \left( \frac{R_1 L}{2} \right) + 2x \left( \frac{R_2^2 \pi}{43560} \times \frac{\alpha}{360} \right) \right] \\ &= \left[ 2 \left( \frac{1268 \times 2050}{2} \right) + 2x \left[ \frac{1581 \times 1581 \times 3.1416}{43560} \times \left( \frac{110}{360} \right) \right] \right] \\ &= 169.8 \text{ Acres} \end{aligned}$$

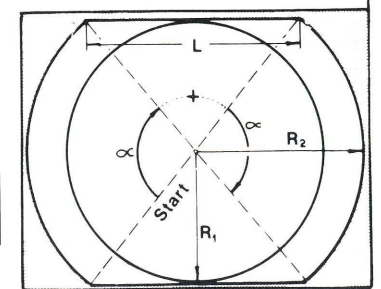

## ODD SHAPE FIELD

$$\begin{aligned} \text{Area} &= \left[ \frac{R_1 L_1}{2} + \left( \frac{R_1 L_2}{2} \right) + \left( \frac{R_1 L_3}{2} \right) \right] + \left[ \frac{R_2^2 \pi}{43560} \times \frac{\alpha_2}{360} \right] + \\ &\quad \left[ \frac{R_2^2 \pi}{43560} \times \frac{\alpha_1}{360} \right] + \left[ \frac{R_2^2 \pi}{43560} \times \frac{\alpha_3}{360} \right] \\ &= \left[ \frac{1268 \times 1650}{2} + \left( \frac{1268 \times 1700}{2} \right) + \left( \frac{1268 \times 1600}{2} \right) \right] + \\ &\quad \left[ \frac{1581 \times 1581 \times 3.1416}{43560} \times \frac{90}{360} \right] + \left[ \frac{1581 \times 1581 \times 3.1416}{43560} \times \frac{15}{360} \right] + \\ &\quad \left[ \frac{1581 \times 1581 \times 3.1416}{43560} \times \frac{26}{360} \right] \\ &= 137.64 \text{ acres} \end{aligned}$$

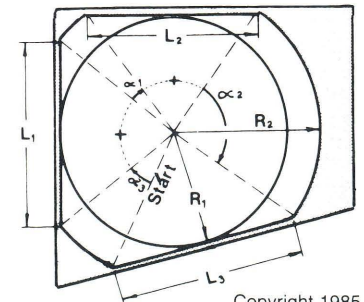

Copyright 1985  
Valmont Industries, Inc.  
Reprinted by permission

NOTE: Lengths & Angles must be measured in the field or from maps, etc./The above dimensions & angles are only typical examples.



MSU is an Affirmative Action/Equal Opportunity Institution. Cooperative Extension Service programs are open to all without regard to race, color, national origin, sex, or handicap.

Issued in furtherance of Cooperative Extension work in agriculture and home economics, acts of May 8, and June 30, 1914, in cooperation with the U.S. Department of Agriculture. W.J. Moline, Director, Cooperative Extension Service, Michigan State University, E. Lansing, MI 48824.

This information is for educational purposes only. Reference to commercial products or trade names does not imply endorsement by the Cooperative Extension Service or bias against those not mentioned. This bulletin becomes public property upon publication and may be reprinted verbatim as a separate or within another publication with credit to MSU. Reprinting cannot be used to endorse or advertise a commercial product or company.

New 4:88-5M-KMF-SP, \$1.50, For Sale Only FILE: 27.2



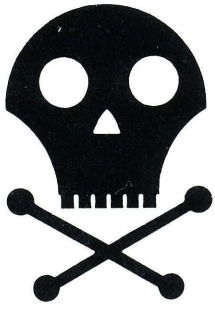

# PESTICIDE EMERGENCY INFORMATION



*(Please post in an appropriate place)*

*For any type of emergency involving a pesticide, the following Emergency Information Centers should be contacted immediately for assistance. This Cooperative Extension Service Bulletin is the latest information available as of July 1987, and replaces all previous listings of similar information.*

## **HUMAN PESTICIDE POISONING**

**Eastern Half of Michigan  
within the Detroit City proper**

**\*(313) 745-5711**

**within the 313 area code**

**\*(800) 462-6642**

**statewide**

**\*(800) 572-1655**

*Poison Control Center  
Children's Hospital of Michigan  
3901 Beaubien  
Detroit, MI 48201*

**Western Half of Michigan  
within the Grand Rapids City proper**

**\*(616) 774-7854**

**within the 616 area code**

**\*(800) 442-4571**

**statewide**

**\*(800) 632-2727**

*Blodgett Regional Poison Center  
Blodgett Memorial Medical Center  
1840 Wealthy, S.E.  
Grand Rapids, MI 46506*

**Upper Peninsula of Michigan  
within the Marquette City proper**

**\*(906) 225-3497**

**Upper Peninsula only**

**\*(800) 562-9781**

*U.P. Poison Control Center  
Marquette General Hospital  
420 West Magnetic Street  
Marquette, MI 48955*

## **SPECIAL PESTICIDE EMERGENCIES**

### **Animal Poisoning**

Your Personal Veterinarian

( ) -

and/or

Animal Health Diagnostic Laboratory  
Michigan State University

**(517) 353-1683**

### **Pesticide Fire**

Local Fire Department

( ) -

and

Fire Marshal Division, Michigan State Police  
(Local authorities will assist in contacting the State Fire Marshal)

### **Traffic Accident**

Local Police Department or Sheriff's Department

( ) -

and

Motor Carrier Division, Michigan State Police

( ) -

### **Environmental Pollution**

Pollution Emergency Alerting System (PEAS)  
Michigan Department of Natural Resources

**\*(800) 292-4706**

### **Pesticide Use Incident**

Pesticides & Plant Pest Management Division  
Michigan Department of Agriculture

**(517) 373-1087**

**\* Telephone Number Operated 24 Hours**