

MSU Extension Publication Archive

Archive copy of publication, do not use for current recommendations. Up-to-date information about many topics can be obtained from your local Extension office.

You Can Do It: Locks and Doors
Michigan State University
Cooperative Extension Service
Department of Human Environment and Design
Department of Agricultural Engineering
Department of Urban Planning and Landscape Architecture
January 1979
8 pages

The PDF file was provided courtesy of the Michigan State University Library

Scroll down to view the publication.

discontinued FILE # 18-16

you can do it

COOPERATIVE EXTENSION SERVICE

Departments of
Human Environment and Design
Agricultural Engineering
Urban Planning and Landscape Architecture

MICHIGAN STATE UNIVERSITY

Extension Bulletin E-1111

Reprinted January 1979

LOCKS AND DOORS



Security in homes is obtained in two ways: (1) constructing the house to be as burglar proof as possible and (2) managing the house to discourage burglars.

Windows

Windows are often a vulnerable spot. Many times they are behind shrubs or on sides of the house shaded from lights so they can be forced open, broken, and worked on without being seen.

The first step in securing windows against burglars is to replace the glass with unbreakable or burglary resistant glass. This type of glass cannot be cut with a glass cutter or broken easily by the burglar. Secondly, each window in your home should have a lock of some type. The single twist lock that appears on double hung windows gives little protection because it can be easily forced.

For maximum security use the security glass, the single twist lock and an additional lock similar to that shown in Figure 1. This lock can be locked without a key but you must a key to unlock it so be sure the key is stored close by in case of emergency. A simple homemade lock is to drill a small hole through the inside frame of a double frame window and about half way into the outside frame. Drill it at a slight downward angle to the outside. Then insert a nail or small bolt into the hole. Install one lock on each side of the window, Figure 2.

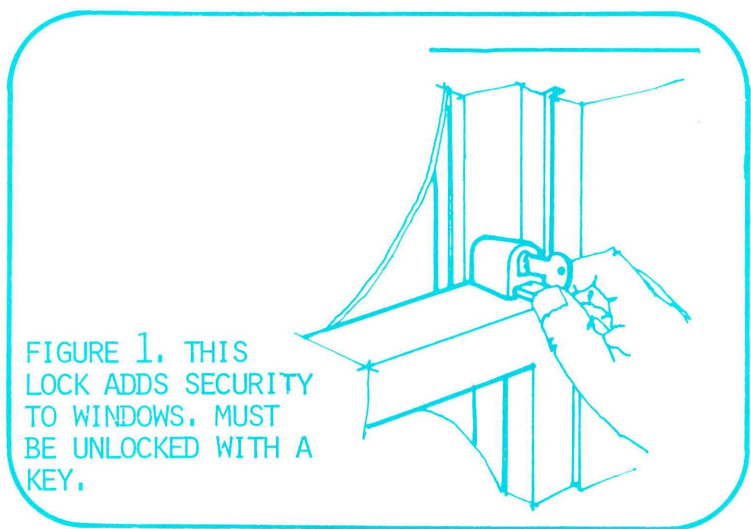

FIGURE 1. THIS LOCK ADDS SECURITY TO WINDOWS. MUST BE UNLOCKED WITH A KEY.

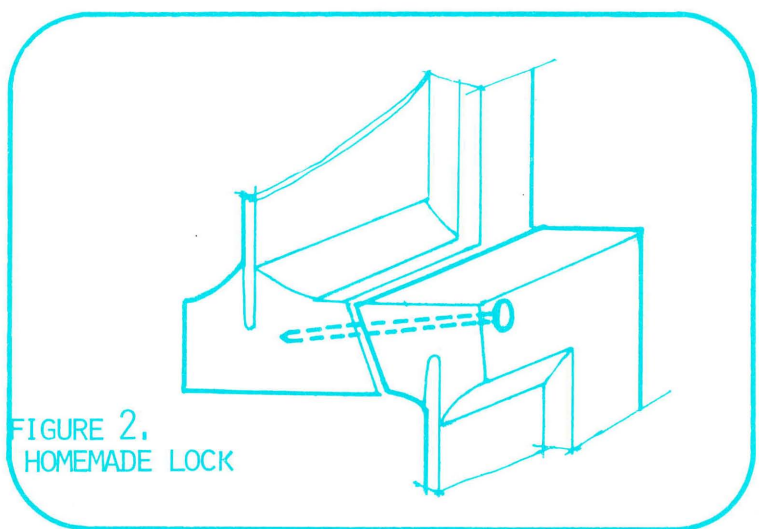

FIGURE 2. HOMEMADE LOCK

James S. Boyd, Professor and Extension Housing Specialist, Agricultural Engineering and Human Environment & Design Departments, November, 1976.

Concepts in this publication have the support of the Michigan Rural Crime Prevention Council.

Doors

Choosing a type of door is important to security. Doors containing glass are easy to enter. Glass can be broken to get to the lock inside. All exterior doors should be of solid core construction or be metal doors. Rabbeted door jambs should be used rather than using a door stop nailed to the frame. Thin paneled doors and hollow core doors should be lined with steel if possible. The best type of door would be completely solid with wide angle viewers.

Glass panels or sidelights located along the side of doors provide easy access unless glazed with laminated polycarbonate security glass.

Exterior doors should have three hinges equipped with non-removable hinge pins. It is best to use 3" screws in the hinges so that when screwed to the frame they go into the rough door frame. The door should fit tightly in the frame so a burglar cannot jiggle or pry the door to release the lock. Sometimes metal strips can be used to line the door or frame to cover the space between the door and door jamb and to stiffen the door or frame.

Locks

An adequate system of locks is one of the most important security precaution once the construction is correct.

Remember a lock that locks with a spring can easily be forced with a knife, credit card or wire. Also rim lock, double action locks or night locks that operate from inside with a twist knob are easy to unlock. If a burglar is inside the house he can escape easily carrying his loot. Just turn the knob and walk out.

A good lock to use is some type of double cylinder dead-bolt lock, Figure 3, or self-locking dead-bolt lock, Figure 4, on all outside doors. The bolt or latch should extend at least 1/2" into the strike plate on the door jamb. This will require the bolt or latch to extend more than 1/2" from the door. On many good locks the bolt will extend one inch from the door.

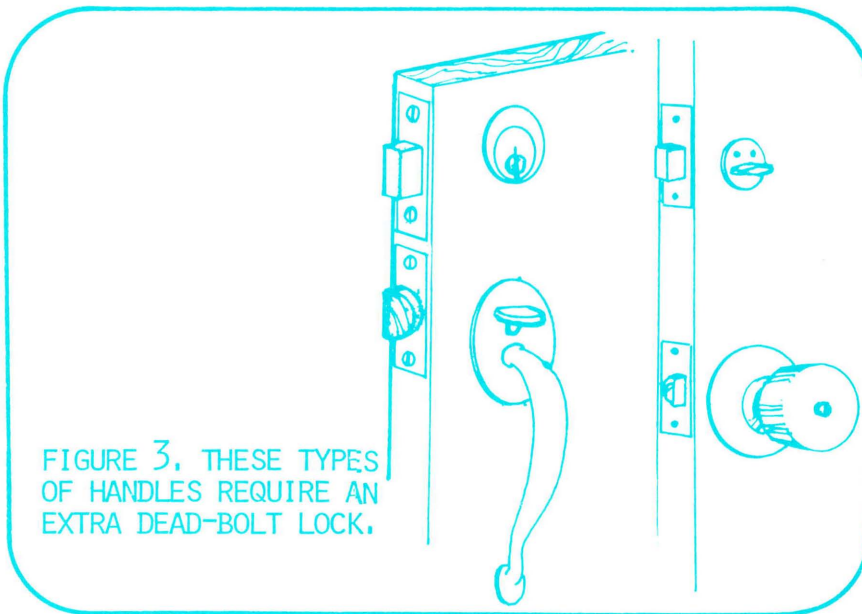

FIGURE 3. THESE TYPES OF HANDLES REQUIRE AN EXTRA DEAD-BOLT LOCK.

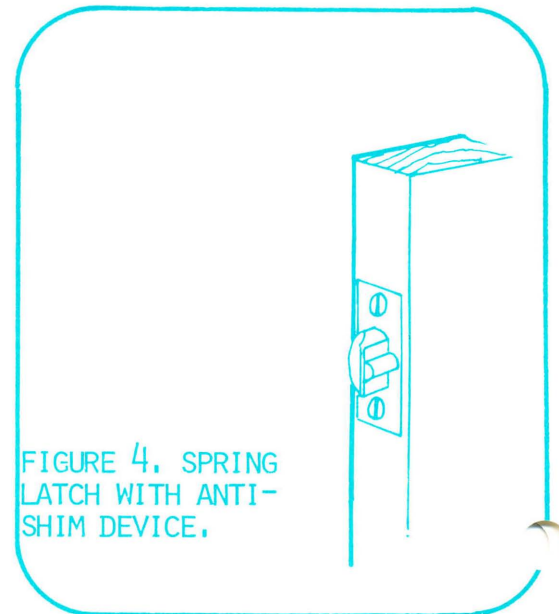

FIGURE 4. SPRING LATCH WITH ANTI-SHIM DEVICE.

Another good type of lock has an interlocking bolt (Figure 5). This type of lock cannot be forced even though the cylinder is removed.

All locks should be mounted with 2-1/2" or 3" screws so they will hold if the door is forced. It is recommended that locks be mounted about 1/2 of the way down from the top of the door. More than one locking device is suggested to discourage burglars.

Glass patio doors are harder to lock. The simplest way is to lay a board or rod in the track. It should be cut to the exact length so the door cannot even be opened enough to get a wire through. Then round bead screws should be screwed into the top track so when the doors are closed they cannot be lifted out of the track. (Figure 6).

MANAGING FOR SECURITY

Mark Your Property

One of the effective methods of discouraging thieves is "Operation Identification" which is promoted by police departments and insurance companies. Their system includes marking items with your drivers license number. Example: P 000 000 000 000. A small electric etching tool is used to do the marking. Police departments and some insurance companies have these tools to loan. After your items are marked they issue you a sticker to put on doors indicating your property is marked. This becomes a permanent identification and cannot be removed. If you do not have a drivers license, use a relative's drivers license.

Know Your Neighbors' Plans

Neighbors can be the best security system. This system begins with an awareness of the neighbors living patterns and sharing of information concerning trips, vacations, etc. By knowing each others living patterns, you can be alert to strangers and strange vehicles in the neighborhood.

If you notice suspicious or strange vehicles in the neighborhood, write down the vehicle license no., make, color, etc., in case a home is burglarized. Service vans with names on the side should be observed as homes can be burglarized by people posing as repairmen.

WAYS TO DISCOURAGE BURGLARS

Daily routine

1. Maintain an adequate system of door locks and alarms.
2. When answering the door, use peephole or interview grill; do not allow strangers to enter before checking his credentials and identification.
3. Do not leave notes on exterior of home indicating you will be gone for a short time.
4. Place lights for minimum shadows and maximum security.
5. Do not advertise or sell items in the paper using your name, address, and telephone number. Use a box number.
6. Do not hide keys around house exterior.
7. If you are a woman living alone, use your initials rather than Mrs., Miss, or Ms. on door, mailbox, and in telephone directory.
8. Place jewelry, negotiable securities, and other expensive valuables in a bank-deposit box.
9. Don't make tools available to the intruder. Put ladders and screwdriver, crowbar, etc., in a locked room, basement or garage. Mark these with your drivers license or a friend's license number.

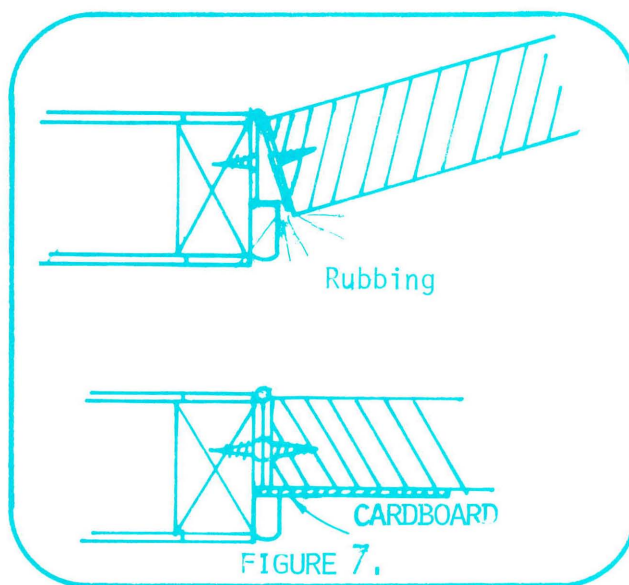
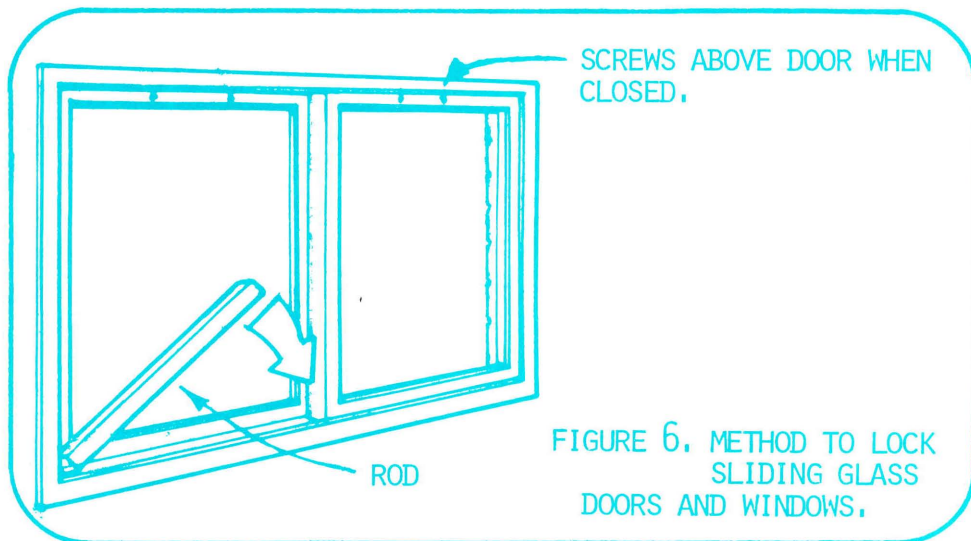
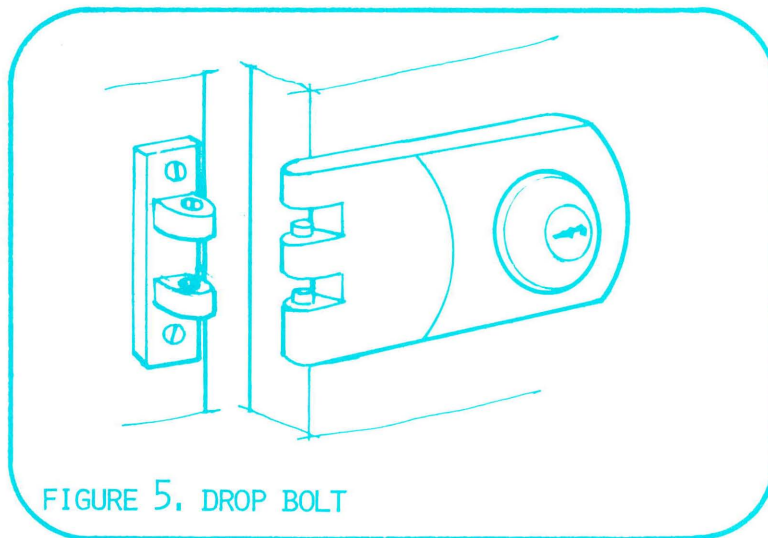

Daily Routine - continued

10. Keep all garage doors locked. When away from home, keep them shut.
11. Lock all doors and windows on all levels of the home at night or when leaving home.
12. If you are leaving home for a few hours, leave the radio and a light on in the bedroom or upstairs level. Don't give your house a closed-down appearance.
13. Never leave credit cards in unoccupied home

When Away From Home

1. Create appearance that house is occupied.
2. Cancel deliveries - mail, newspaper, milk, etc.
3. Turn telephone bell down if possible.
4. Use a timing device to turn on a bedroom light and radio.
5. Notify the police and neighbors that you will not be home.
6. Park a second car in the driveway.
7. Arrange for someone to cut the grass.
8. In winter, arrange for someone to shovel snow from your walk.
9. Arrange for someone to drive a car up and down the driveway and walk around the outside of the house after a snowfall.
10. Do not put an announcement of your absence in the paper or discuss it with strangers.
11. Leave an extra key with a neighbor so that your home may be inspected by police or a neighbor if necessary.
12. Set trash cans inside.
13. Turn heat down, not off; frost or ice on windows indicates an unoccupied house.

GOOD DOORS/LOCK PROVIDE GOOD SECURITY

Door problems fall into three general groups: 1) the door doesn't shut, 2) the hardware doesn't work, or 3) the door doesn't fit properly into its frame when it is shut.

When the Door Doesn't Close

If the door closes in winter when the heat is on but will not close in the summer during high humidity conditions, the wood is probably expanding due to the humidity. On the latch side notice where it is binding and mark with a pencil where to plane the door. Do not take off more than about 1/8".

When the door binds at the latch so it bumps on the latch plate, it may be easier to remove the hinges and do the planing on the hinge side. Remember to also remove an equivalent amount of wood under the hinges with a wood rasp or a chisel.

Remember that when the door shrinks, the strike plate may have to be adjusted so the latch will hold.

Door Closes but Binds in the Frame

A door that closes but binds on one of the corners may be an indication that the door hinges are loose, or if the problem keeps occurring the foundation and/or frame may be shifting.

The first step is to check the hinges. Be sure all of the screws are tight. If the screw continues to turn, remove it and replace with a screw the same diameter but 1/2" to 3/4" longer. Another solution is to fill the screw hole with toothpicks dipped in glue. After the glue sets for about 24 hours, redrill a lead hole and put in the old screw.

If the screws are all tight and you still must keep planeing off the same corners each year or so, hire a carpenter or contractor to determine what is the problem. Occasionally the sticking problem is on the hinge side of the door. Look to see if the door is rubbing the stop strip nailed to the door frame, Figure 7. If it is, remove the strip on the hinge side with a chisel or putty knife being careful not to damage the strip. Remove the nails. Remail the strip next to the door with a piece of cardboard between to allow for clearance between the strip and the door.

Some door frames are rabbetted so the door closes into a grove in the frame and there is no strip to remove. About the only solution is to carefully sand or plane the back edge of the door along the hinge side so the door clears the frame when closed.

Sometimes the door is hard to close but doesn't seem to bind between the door and the frame. Loosen the hinge screws and insert a cardboard shim under the hinge. This should be done under both hinges.

If you have a door that needs to be slammed shut or leaned against to close, the problem

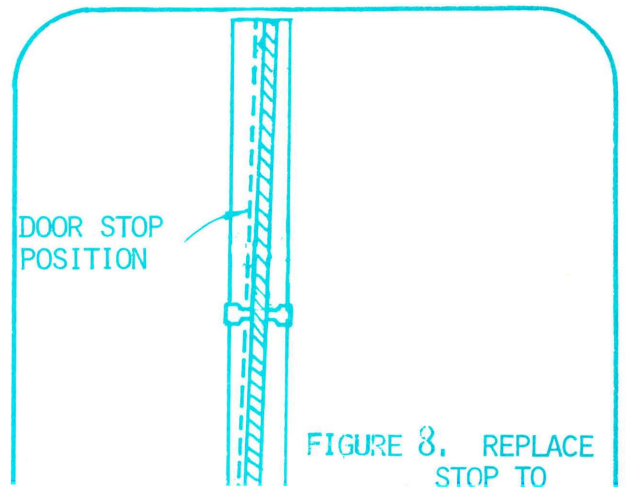

FIGURE 8. REPLACE STOP TO

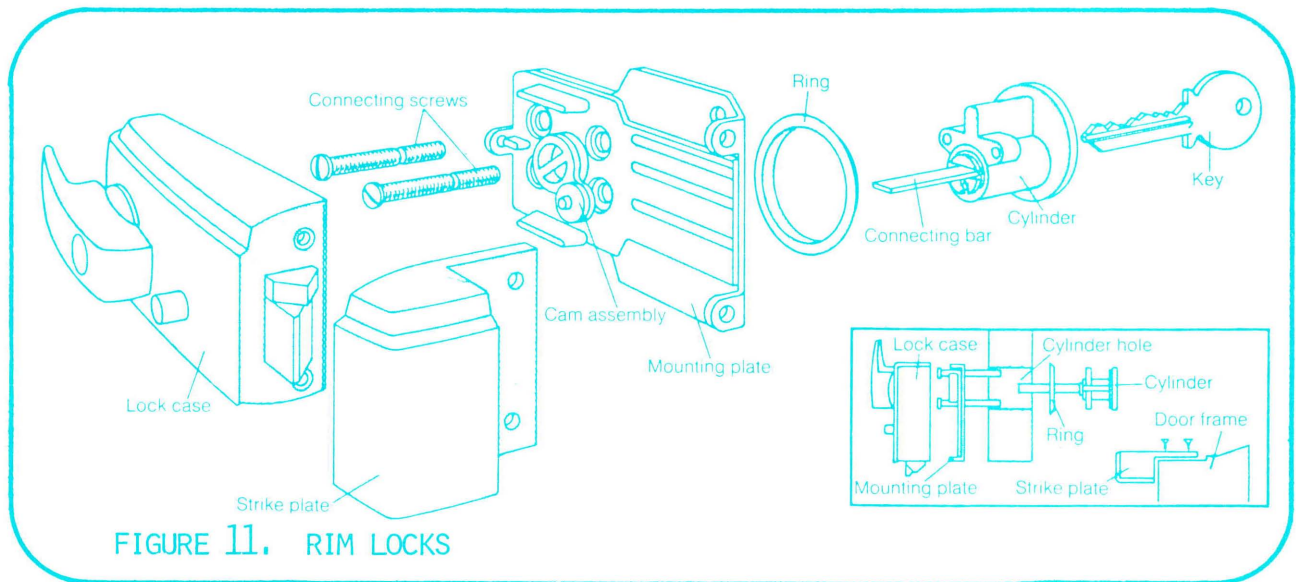
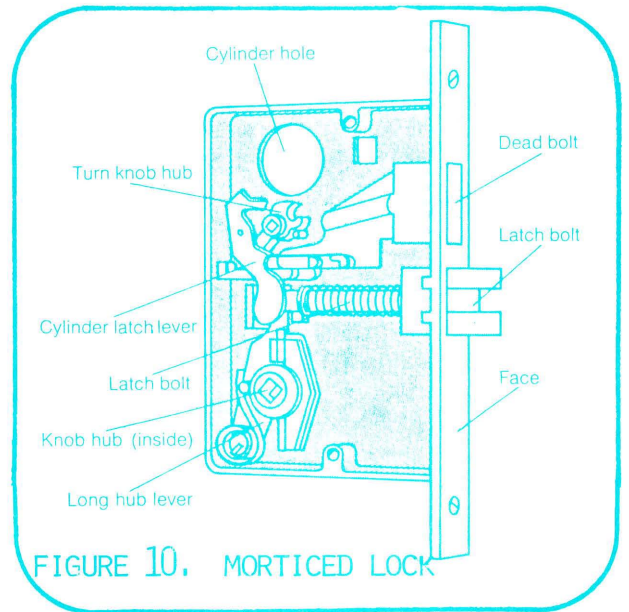

FIGURE 11. RIM LOCKS

Tubular locks, Figure 12, are for inside doors and do not use keys. Some have a push button to lock it as shown in the picture. It is installed by drilling a large hole through the door large enough so the attaching stems will go through and fasten to the "rose" on the other side. Another hole is drilled into the edge of the door large enough to take the latch bolt assembly. The exact location is included with the hardware. Usually a safety device is included which is a hole in the outside knob so a stiff wire can be inserted to push out the push button.

The Door Latch Doesn't Work

There are four types of door locks. Mortised locks are used in older houses. Figure 10. Most have some type of dead bolt that locks with a key in addition to the spring latch. These cannot be used on an outside door that is less than 1-3/8" thick.



Rim locks, Figure 11, are often referred to as night locks and are in addition to a mortise lock. To mount, a hole as large as the cylinder is drilled through the door. The two connecting screws fasten the cylinder on the outside to the connecting plate on the inside. Follow instructions that come with the lock. The striker plate is fastened to the door frame so the latch matches the hole in the striker plate.

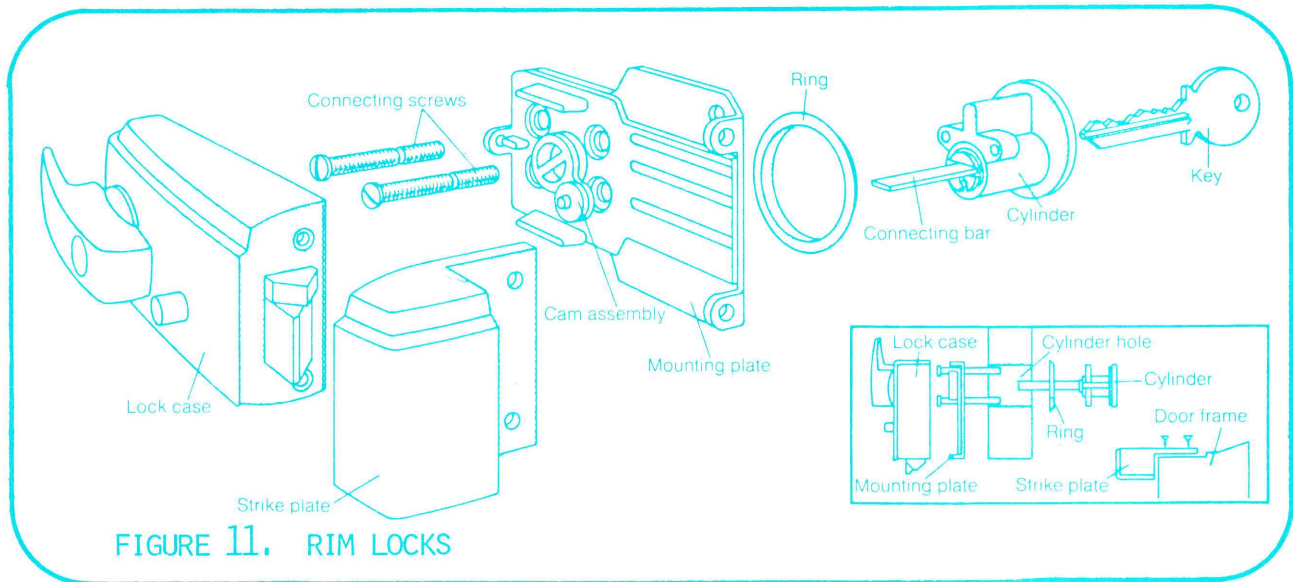

Tubular locks, Figure 12, are for inside doors and do not use keys. Some have a push button to lock it as shown in the picture. It is installed by drilling a large hole through the door large enough so the attaching stems will go through and fasten to the "rose" on the other side. Another hole is drilled into the edge of the door large enough to take the latch bolt assembly. The exact location is included with the hardware. Usually a safety device is included which is a hole in the outside knob so a stiff wire can be inserted to push out the push button.

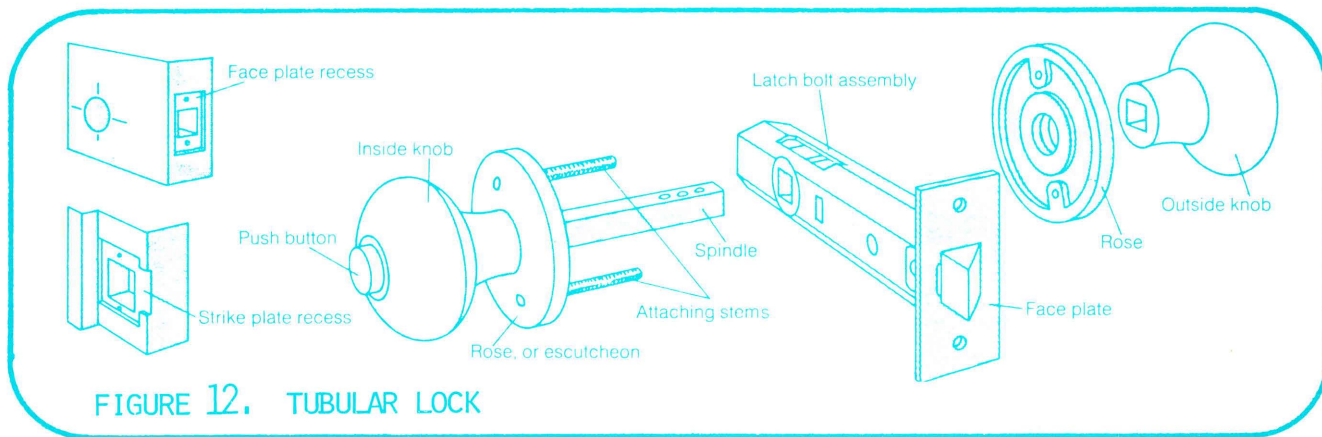

Cylindrical locks are used for outside doors and provide minimal security. It is locked with a key from the outside and/or by pushing a button or pushing and turning the inside knob. They are installed by drilling a hole large enough to take the cylinder case through the door. Also a hole large enough to take the latch is drilled into the edge of the door. Instructions are included with the hardware.

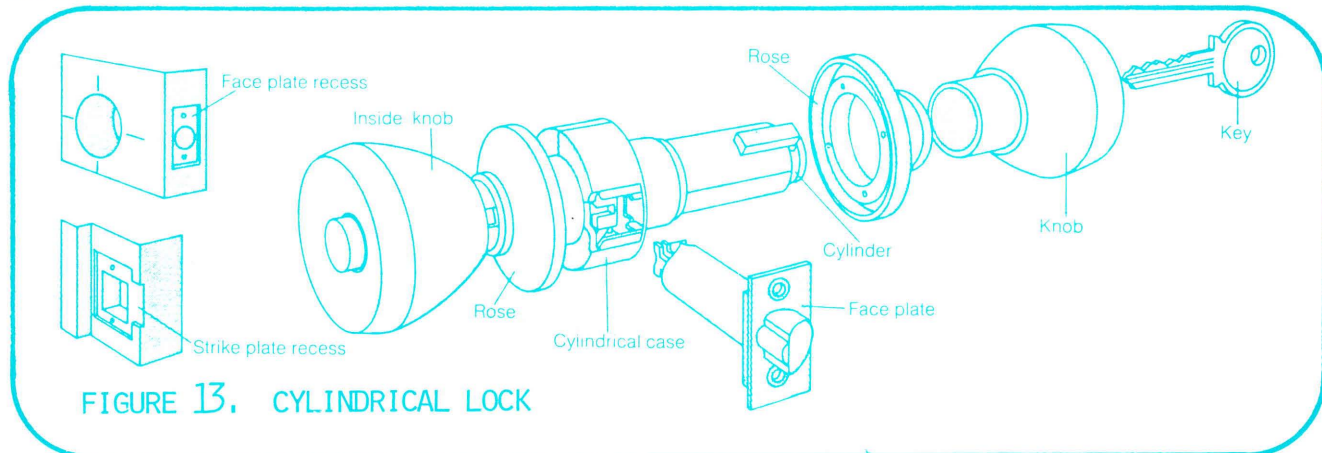

If you plan to replace a lock, the following information will help to select a new lock:

1. The type of lock being replaced _____
2. Manufactured by _____
3. Door thickness _____
4. Dimensions
 - A. Backset measure _____
 - B. Diameter of lock hole _____
 - C. Diameter of latchbolt hole _____
 - D. Latch unit face length _____ width _____

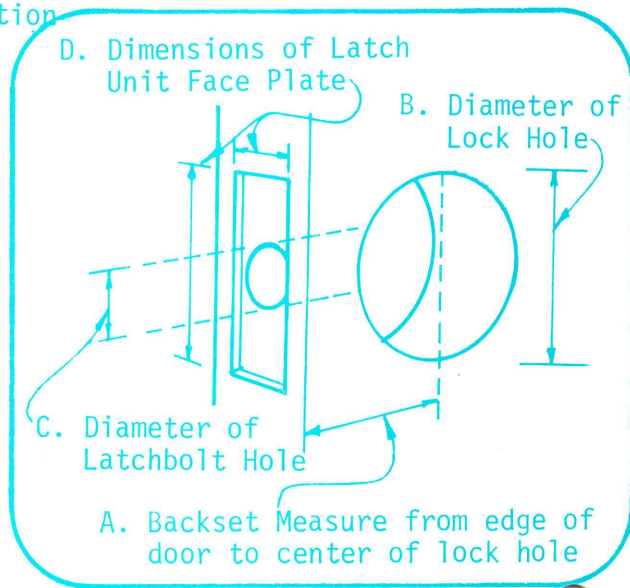

FIGURE 14. INFORMATION NEED TO BUY A LOCK

Figures 10, 11, 12, & 13 - Pictures from "THE READER'S DIGEST COMPLETE DO-IT-YOURSELF MANUAL. Copyright c 1973 The Reader's Digest Assn., Inc."

Material based in part on "Safeguard Your Home" Cheryl Heide and Charlene Jacobs, University of Kentucky.