

MSU Extension Publication Archive

Archive copy of publication, do not use for current recommendations. Up-to-date information about many topics can be obtained from your local Extension office.

Clear Span Roof Construction

Michigan State University Agricultural Experiment Station

Circular Bulletin – Farm Building Series

M.L. Esmay, J.S. Boyd, B.F.Cargill, Agricultural Engineering

Issued November 1956

12 pages

The PDF file was provided courtesy of the Michigan State University Library

Scroll down to view the publication.

Farm Building Series - Circular 732

18.103

CLEAR-SPAN ROOF CONSTRUCTION

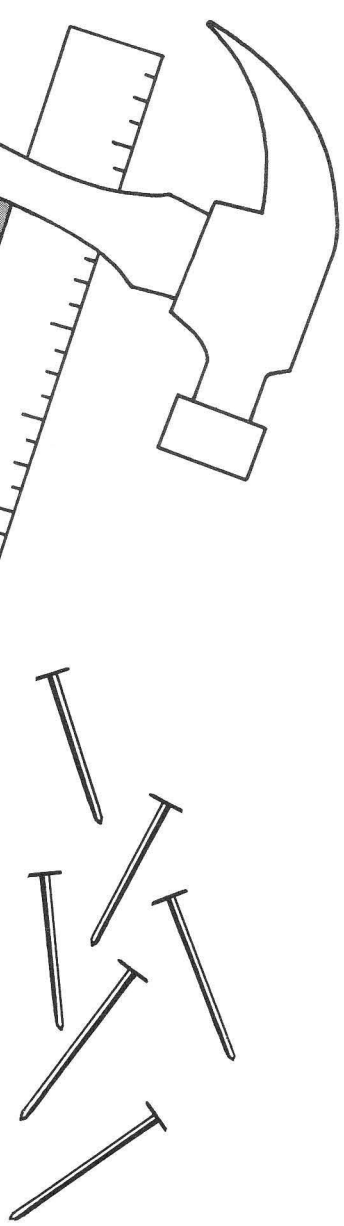
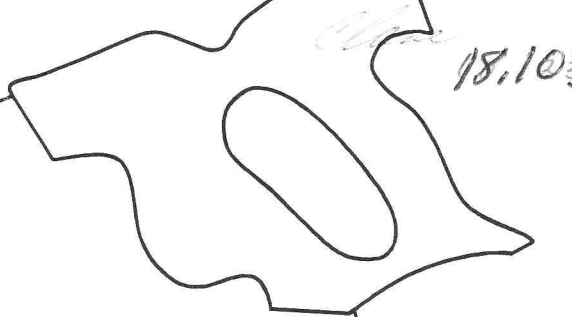
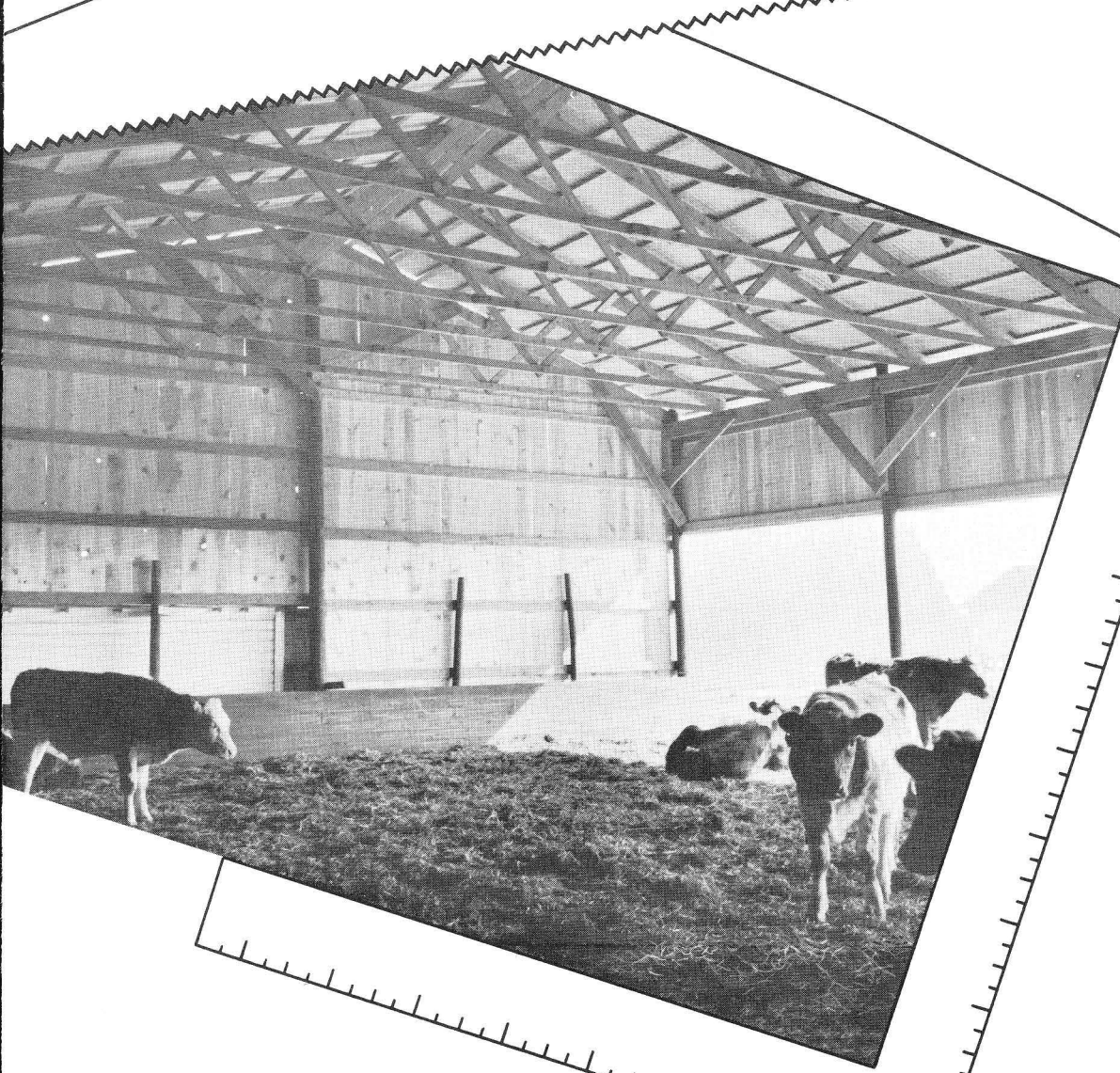

By
M. L. Esmay, J. S. Boyd, B. F. Cargill

MICHIGAN STATE UNIVERSITY

Cooperative Extension Service

Department of Agricultural Engineering ♦ East Lansing

TABLE OF CONTENTS

	Page
ADVANTAGES OF CLEAR-SPAN CONSTRUCTION	3
ERECTING CLEAR-SPAN BUILDINGS.....	3
Wood Trussed Rafters.....	3
Truss Design.....	3
Ring-Bolt Trusses.....	4
Glue-Nail Trusses.....	6
Glue Selection.....	8
Erection	8
Anchorage	9
Roof Application.....	9
Plans	10

Cooperative extension work in agriculture and home economics. Michigan State University and the U. S. Department of Agriculture cooperating. Paul A. Miller, Director, Cooperative Extension Service, Michigan State University, East Lansing. Printed and distributed under Acts of Congress, May 8 and June 30, 1914.

Clear-Span Roof Construction

by M. L. Esmay, J. S. Boyd, and B. F. Cargill

Department of Agricultural Engineering

ADVANTAGES OF CLEAR-SPAN CONSTRUCTION

Clear-span one-story farm buildings eliminate inside posts and poles and allow farmers a wide range of uses.

Clear-span construction has these advantages over inside supports for different types of farm buildings:

1. Machinery storage buildings
 - Better use of available space for storage of machinery.
 - Easier movement of machinery into and out of buildings.
 - Allows for side opening or drive-through types of buildings.
2. Livestock shelters
 - Easier to clean with tractor and loader.
 - Fewer injuries to livestock.
 - Better adapted to different types of livestock.
3. Hay storage buildings
 - Better adapted to self-feeding and movable bunks.
 - More suited for hay drying systems because there are no interior poles to "shortcut" the air circulation.
4. Fruit and vegetable storage structures
 - Easier to move fruit in and out with mechanical lift trucks.
 - Increases storage capacity up to 5 percent or more.

ERECTING CLEAR-SPAN BUILDINGS

Wood Trussed Rafters

By using wood trussed rafters, clear-span construction costs no more than ordinary construction. Savings from eliminating interior posts, poles, and roof purlins and from reducing the size of some of the parts, will offset any added cost of the trussed roof. The upper cord, or rafter part, of the truss can be smaller than with inside supports because it is supported at its center by one of the braces of the truss;

good fasteners utilize full strength of wood. All the other members of the truss are 2 by 4's.

Roof trusses can be precut and preassembled on the ground. Workmen can accomplish more on the ground than on scaffolds.

Truss Design

Wood trussed rafters designed for spacing 4 feet on center are very practical for farm buildings from 24 to 40 feet wide. Fig. 1 shows how to use the truss for a 36-foot-wide poultry house.

The weakest parts of most farm-building construction are the joints. This is not so in truss construction because strong fasteners (such as bolts and ring connectors, or glue and nails) are used. These fasteners allow nearly the full strength of the wood to be used; with nails alone, only a small portion of the available fiber strength is used.

Fig. 2 compares the strength of various types of common fasteners. It takes 30 16d (16 penny) spikes or six ½-inch bolts to carry a 3,000-pound design load. One ½-inch bolt with a 2½-inch ring connector, however, will carry the same load. A glue and nail joint of about 15 square inches will also carry the same load. Any joint large enough to take 30 spikes, or even six bolts, would have to be very large. Large wood parts—called members in this circular—which are used only to accommodate fasteners add unnecessary cost to the building. A joint using glue and nails is almost ideal because it uses nearly the full strength of the wood.

Trusses are especially rigid because they are formed from a series of triangles. The trusses described in this circular contain five triangles, which give the rigidity needed. Even though a bolt and split-ring connector would normally act as a pivot, the triangular design makes these clear-span joints rigid and strong; there is no chance of their pivoting.

In the poultry house shown in Fig. 1, the joint fasteners are ¾-inch plywood gusset plates which have been glued and nailed in place. This construc-

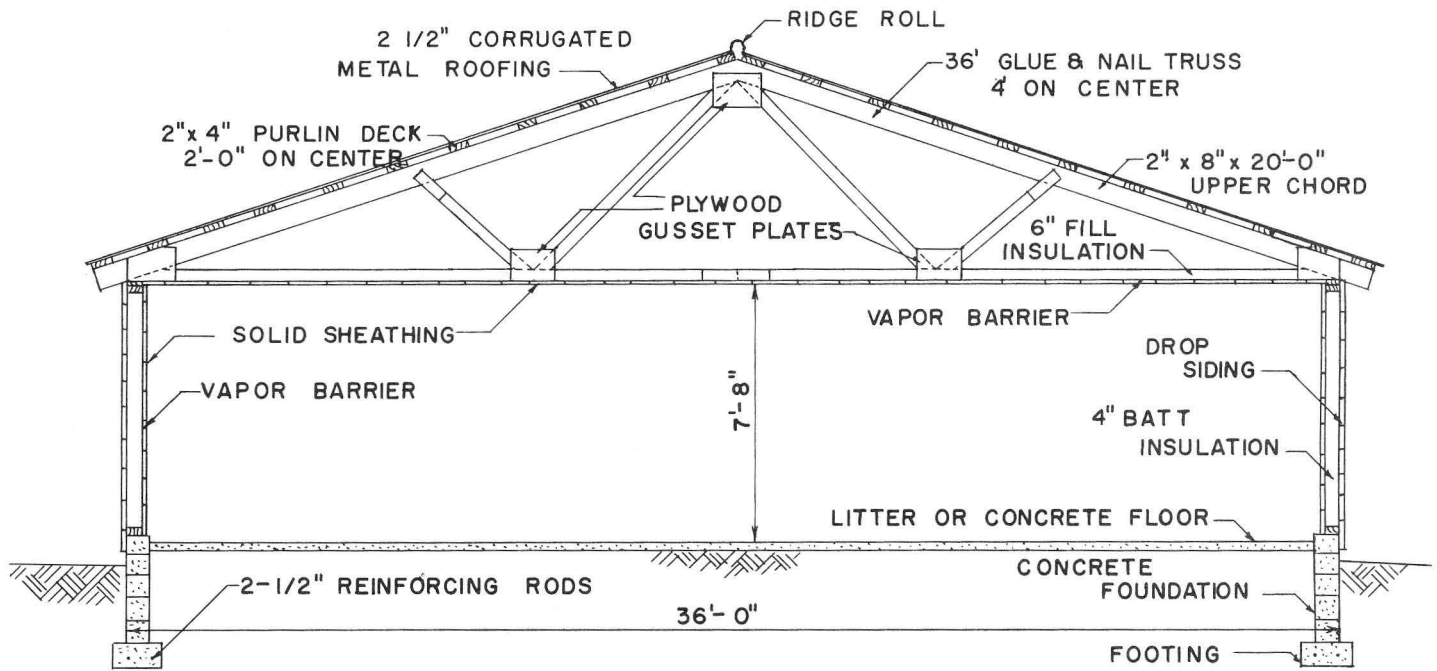
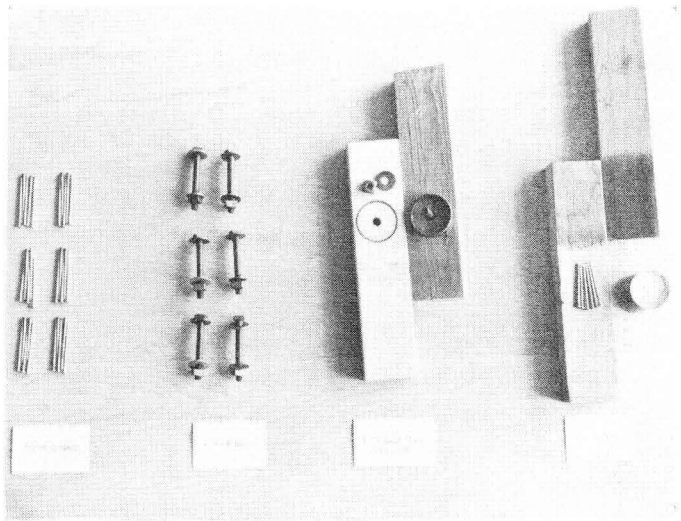

Fig. 1. A 36-foot glue-nail wood truss as applied to a poultry house. The clear-span feature allows many more arrangements of equipment, such as feeders, waterers, cleaners, roosts, and nests. Building might also be adapted to other uses.

tion makes very rigid joints and, therefore, a very rigid truss.

The trusses have been designed so that they can be assembled easily on the ground, then lifted as a complete unit into place on the sidewalls. For the ring-bolt and the glue-nail trusses, the members can be cut out on a production basis, once the patterns

Fig. 2. Four types of fasteners, showing the number of each needed to provide joints of equal strength. The 30 16d nails would be impossible to put in ordinary sized members; 2- by 6-inch members would be needed for the six bolts, compared to 2- by 4-inch members needed for the ring connector or glue-nail joint.



have been made. All members in wood truss construction are 2-inch lumber.

Ring-Bolt Trusses

You can get detailed truss plans at your county agricultural agent's office. The plans give complete dimensions for cutting and drilling each truss member.

First, cut the members to length. Then locate holes and drill them for half-inch bolts with a $\frac{1}{16}$ -inch bit. The last operation in shaping the members is cutting the grooves for the split-ring connectors.

You will need a special cutting tool for cutting the groove for these 2½-inch diameter ring connectors. The grooving operation is shown in Fig. 3. With power equipment, this operation is very simple. The guide for the grooving tool slips down into the pre-drilled hole for the bolt and properly locates the groove. Set the grooving tool so that it cuts the groove just deep enough to insert the ring halfway into each member.

Fig. 4 shows how the members are assembled after the bolt holes and ring grooves have been cut. Place the rings in the grooves of one member; place the other member on top. The ring then projects one-half way into each of the two members. The ring

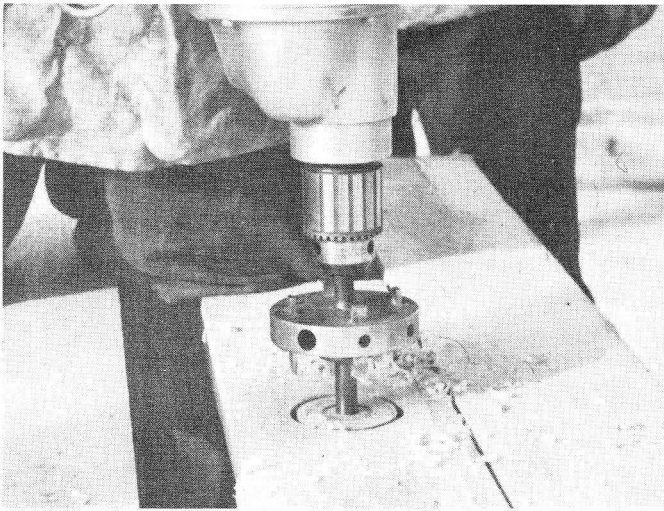
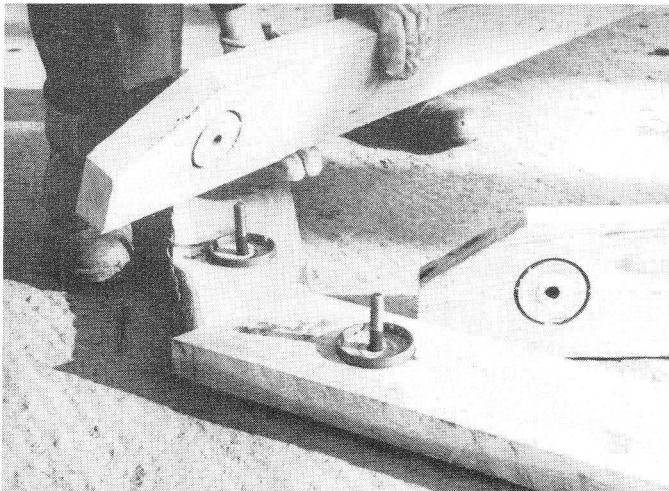

Fig. 3. A special grooving tool is used to cut a groove so split-ring connectors can fit halfway into each truss member. The tool fits in a half-inch electric drill. A 9/16-inch hole is first drilled in the member at the proper location so that it can be used as a guide in cutting the groove.

makes the joint much stronger because it prevents the two members from sliding past each other.

Fig. 5 shows the on-the-job assembly of a ring-bolt truss. The example shown is a 40-foot machine shed under construction. The concrete slab approach to the building made a fine place to assemble the roof trusses. Cut the members for only one truss; then assemble it to see that all cuts, bolt holes, and ring grooves have been located properly before cutting the rest of the trusses. This will uncover any errors made while laying out and cutting the various members.

Fig. 4. After the bolt holes have been drilled and the ring grooves cut, the members can easily be assembled on the ground.



You must locate the holes for a ring-bolt truss accurately and drill them straight or you will have trouble assembling the truss.

If you run into trouble in assembling the trusses, try using a jig. Fig. 6 shows the truss members being drilled in a jig which holds all members in the exact position they will have in the truss. To make the jig, lay 2-inch boards along the side of each truss member; then fasten them together with bolts and rings. Remove the first truss and the jig is ready. Put the new members in, clamp securely, and drill. Remove them completely grooved and assembled.

Fig. 7 shows the ring-bolt jig layout and gives a step-by-step procedure.

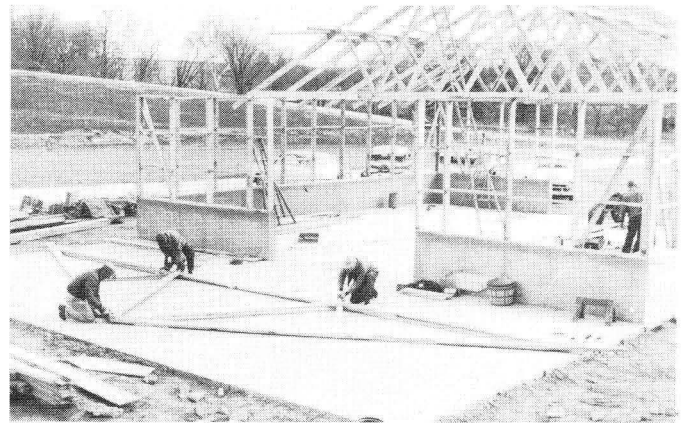
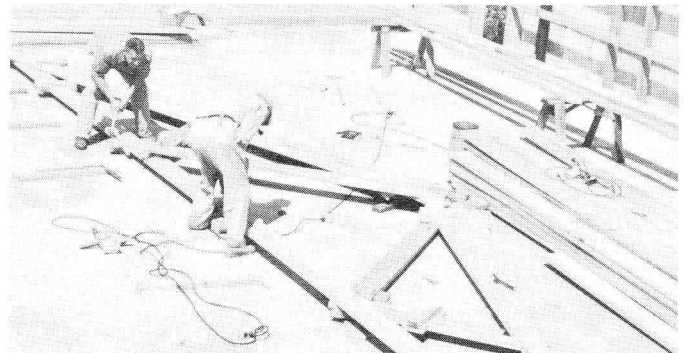

Fig. 5. In the construction of this trussed roof machine shed, the ring-bolt trusses are being assembled on the concrete approach in front of the building. All members and fasteners are fitted into place before the bolts are tightened.

Fig. 6. For this trussed roof poultry house, the ring-bolt truss members are being drilled in a jig. The jig holds all members in the exact position they will have in the truss. Once the holes have all been drilled straight and accurately, the members are removed from the jig, grooved, and assembled into a truss.



Instructions for Building Ring-Bolt Trusses By Using A Jig

Jig Assembly

1. Pick out straight lumber for the first truss and jig.
2. Lay out the first truss from the ring spacing detail. Drill, groove, and assemble with rings and bolts.
3. Block up the assembled truss on a flat surface so the members are in plane. Have clearance above the floor for the drill.
4. Clamp the jig members alongside the first truss and drill holes in the jig so that rings may be used, but do not allow the rings to stick out and interfere with the truss members.
5. Mark the position of the short diagonal on the jig top chord; take the jig members away from the first truss and groove them.
6. Assemble the jig with rings and bolts; nail the short diagonal extension in place on the top chord, so that the top chord is straight.

Truss Assembly

1. Cut the members to length, make angle cuts where

Glue-Nail Trusses

Making a glue-nail truss is somewhat different than making a ring-bolt truss because you must build a rigid jig first. The jig for any truss can be laid out as shown in Fig. 8. In building the jig, make sure to locate the blocks, or continuous jig members, correctly for each truss member. Where a wooden floor is available, nail the blocks directly to the floor; no jig will be needed.

You can build a rigid jig by using continuous members as shown in Fig. 9. In the ring-bolt trusses, the members overlap so they can be bolted together. In the glue-nail trusses, all of the members are in the same plane and, therefore, butt against each other at the joints. In this case you can glue and nail plywood gusset plates on each side to make the joints.

Fig. 9 shows a jig layout with the various members

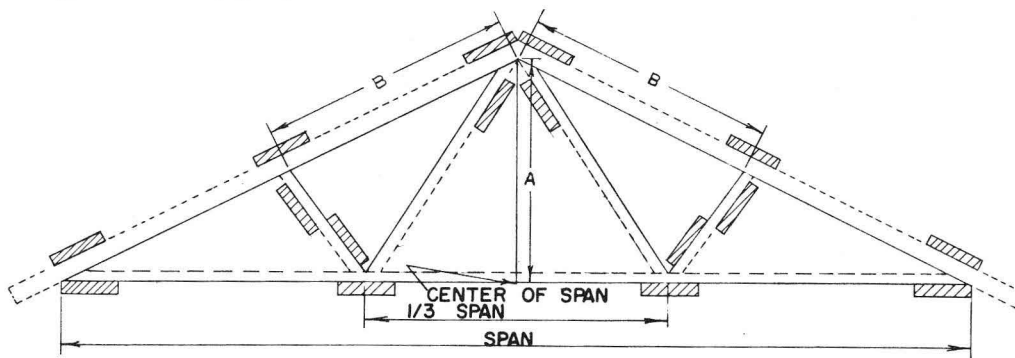

Fig. 8. Glue-nail trusses require a jig to hold members in place while gusset plates are put on the joints. This basic procedure for laying out a jig can be used with any type of jig. Where a wood floor is available, nail the blocks directly to it.

necessary, and drill the top end of the long diagonals before clamping them in the jig.

2. Position the top chords so the top joint is right and drill the ridge hole. Position the lower chords so that the heel joints are right; and join the long diagonals with a half-inch bolt through the ridge joint hole. Mark the position where the short diagonal butts against the top chord.
3. Mark the jig so that the holes are drilled correctly in the rest of the trusses.
4. Drill and groove the members and assemble the joints in the following order: splice, heel, ridge, then the other joints.

JIG WITH TRUSS MEMBERS
SHOWN IN PLACE

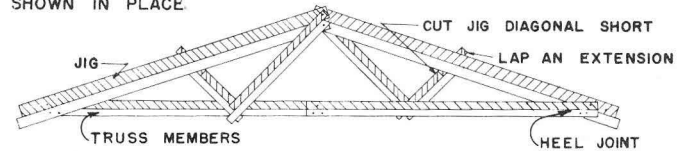

Fig. 7. Details and instructions for building and using a jig for drilling and assembling ring-bolt trusses.

of the truss ready for assembly. In Fig. 10, the truss members have been laid into the jig which holds each of the members in a fixed position for applying the gusset plates.

After building a jig, lay a pattern truss into it and check all of the members for correct size. Then you can precut the pieces for all of the trusses. When assembling the glue-nail trusses, apply glue to the contact areas at each joint where you will nail the gusset plates. You can do this easily with a paddle or paint brush (Fig. 11). Apply an even coating of

Jig Layout

1. Lay off base line (span) with chalkline
2. Locate center of base line
3. Lay off perpendicular line at center of base line
4. Measure distance "A" from plan
5. Lay off rafter base line with chalkline
6. Measure distance "B" from plan
7. Locate the one-third span points
8. Lay off diagonal braces
9. Secure blocks as shown (blocks may be continuous)
10. Check jig with truss members

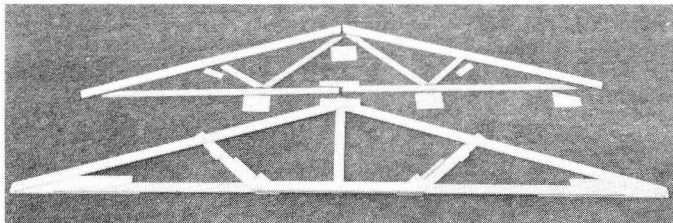

Fig. 9a. The photograph shows a triangular jig. The truss members are laid out in preparation for assembly in the jig.

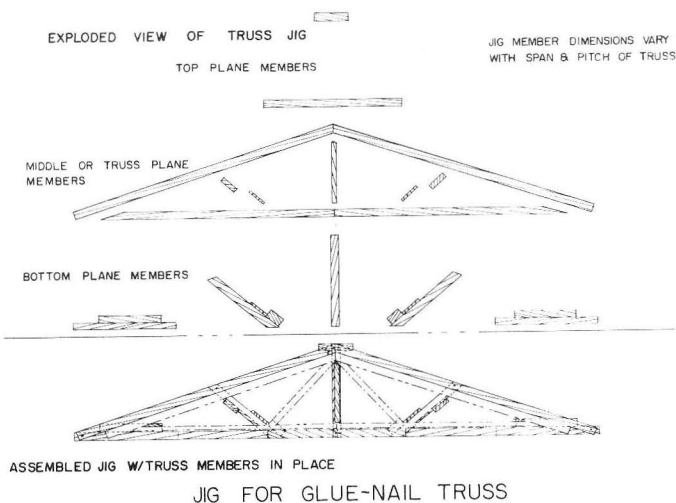

Fig. 9b. The lined illustration shows an expanded view of the same jig as well as the jig with a truss in it.

glue on both the surface of the member and the surface of the gusset plate. As soon as you have applied glue to both contact surfaces, nail the plywood gusset plates in place (Fig. 12).

Nails will hold the members together until the glue sets. Tests of this type of construction show that nails will provide the necessary pressure. Place 6d common nails not more than about 3 inches on center. Where surfaces are irregular, adjust the spacing to be sure contact is made over the whole area. Enough glue has been applied when it can be squeezed out of the joint.

When you have nailed and glued all the gusset plates into place on one side of a truss, lift the truss from the jig. Turn it over to apply the gusset plates on the opposite side (Fig. 13). To do this, stack the trusses to one side; one or two men can glue and nail the gusset plates on the second side. Two other men can then start another truss in the jig. Let the trusses cure at least 24 hours before you place them in position on the roof.

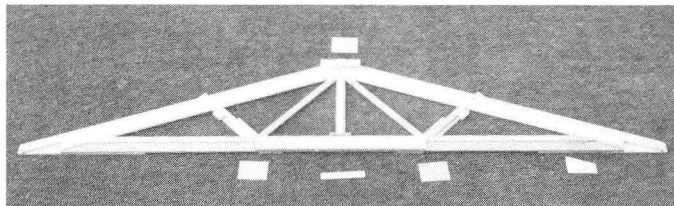

Fig. 10. The truss members are located in the jig, ready for application of the glue-nail gusset plates. Five small blocks along the lower member of the truss wedge the members into a secure position.

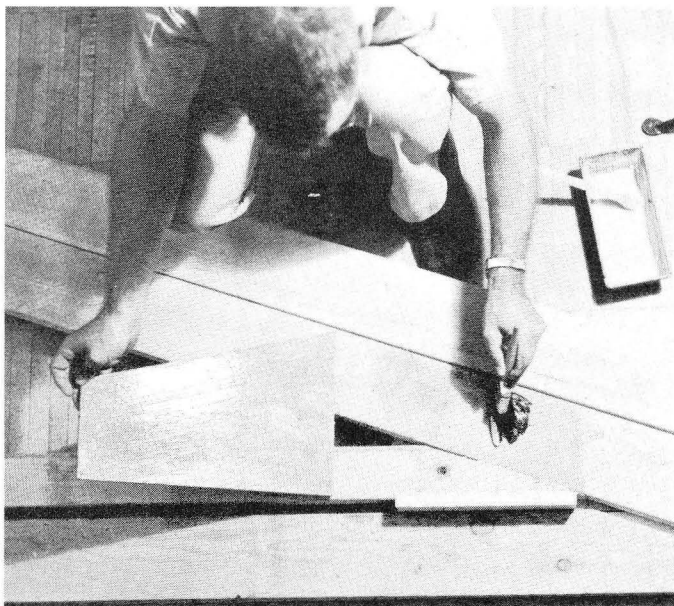
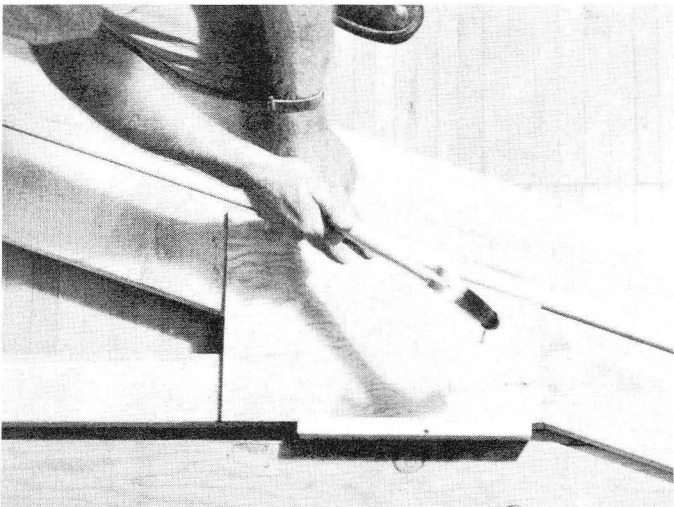

Fig. 11. Glue is applied with a brush to the surface of the plywood gusset plates as well as to the contact surface of the members.

Fig. 12. 6d nails are used to secure the glued gusset plates in place. The nails provide the necessary pressure for the glue to set up and bond the members together. Nails are placed not more than 3 inches apart.



Glue Selection

Several types of glue are on the market today; however, the type A casein (aircraft) glue has proved very satisfactory for farm building construction under most conditions. Where trusses are to be exposed to severe weather conditions or to repeated wetting and drying cycles, use a ring-bolt truss or a waterproof resin glue. These artificial resin glues are more expensive than casein glue, but the cost is justified under extreme wetting conditions (for example, in fruit and vegetable storage buildings where high humidity is maintained).

Erection

The assembly and erection of trusses, both ring-bolt and glue-nail types, can be done in several ways. Perhaps some lumberyards and builders will precut and package all of the truss materials in a central shop location. The trusses can then be delivered to the site in a knocked-down package, or they can be assembled in halves and moved to the building site.

Fig. 14 shows two identical halves of a 40-foot truss which could be shipped easily and cheaply up to 100 or 200 miles. The only joints needed on this truss at the building site are the ridge and lower cord splices. Assembling glue-nail trusses in two identical halves in the shop is desirable because the assembly of glued joints can be controlled more closely there. If ring-bolt trusses are precut accurately in a shop, they can be assembled on the job without a jig.

Fig. 15 shows the erection of a 40-foot truss by two men without the aid of any mechanical hoisting equipment. The trusses, even though quite large, are easily handled in an upside-down position. Once in

Fig. 13. As soon as all of the gusset plates have been nailed into place on one side of the truss, it may be lifted out of the jig and turned over. Gusset plates are then applied to the opposite sides of all joints.

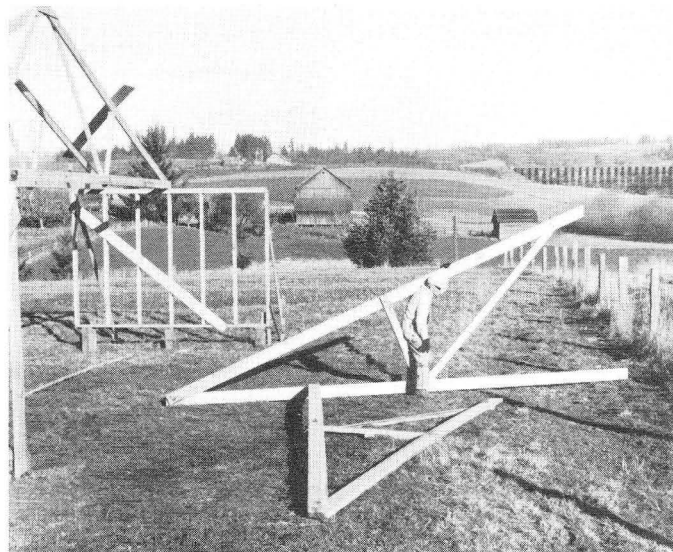
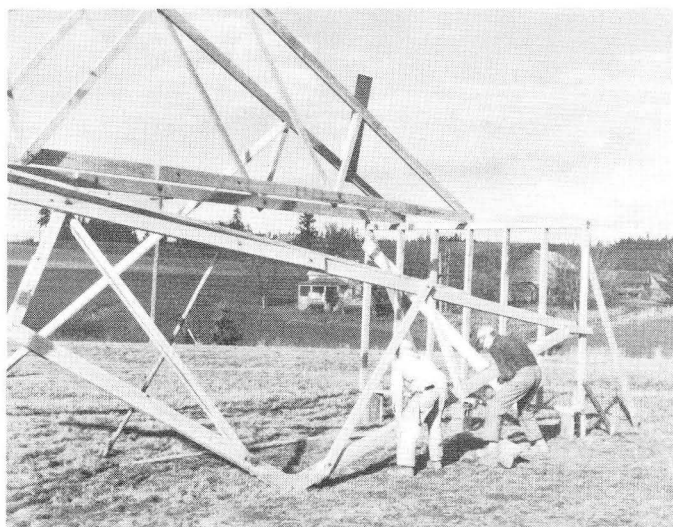

Fig. 14. Ring-bolt or glue-nail trusses can be preassembled in halves at some central location and delivered to the site. Only two field joints are then required.

position, one end is placed on the plate by both men. Then both men are free to lift the opposite end onto the other plate. After the truss ends are placed on the plates, block them into position and pivot the truss into an upright position with pike poles (Fig. 16).

Farm equipment, such as a tractor and hydraulic loader, can also be used for hoisting trusses into place. Fig. 17 shows a utility tractor and loader being used to place 36-foot trusses on a poultry house. An A-frame extension has been built on the end of the loader to provide more height. Large trusses can

Fig. 15. Two men can erect a 40-foot truss on a 10-foot sidewall by lifting one end of the truss up at a time.



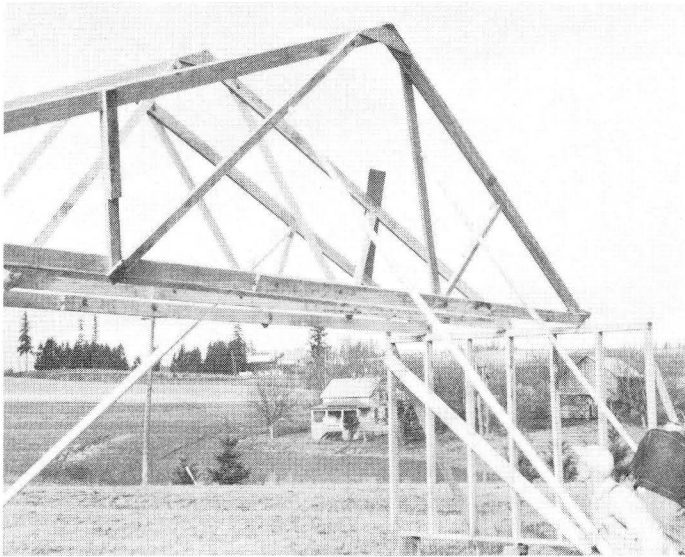

Fig. 16. Once the truss ends are on the wall plate, the truss can be pivoted into an upright position by two men using pike poles.

be placed on high walls (for example, on machine sheds or hay storage buildings) with special hoisting equipment (Fig. 18).

Anchorage

Trusses can be used with post, pole, stud frame, or masonry walls. In all cases, the trusses must be firmly anchored to the wall plate. Figs. 19, 20, and 21 show details of anchoring trusses to building frames. Fig. 19 shows supporting scabs being placed below the rafter supports for pole construction. All of the roof load must be carried by these outside poles; therefore, good support is necessary. Table 1 gives the sizes of rafter supports required for buildings of various spans and poles of various spacing.

Every third truss in a pole building is located at a pole and, for maximum strength, bolted directly to it. Fig. 20 shows the type of anchorage recommended for the trusses located between the poles. The vertical blocks are spiked securely between the rafter supports and to either side of the truss.

Additional anchorage is required for securing trusses to frame walls (Fig. 21); Trip-L-Grips or strap metal are good materials for this purpose.

Roof Application

Trusses are designed for spacing 4 feet on center so that 2-inch by 4-inch roof girts can be nailed to them flatwise (Fig. 22). If the spacing is more than

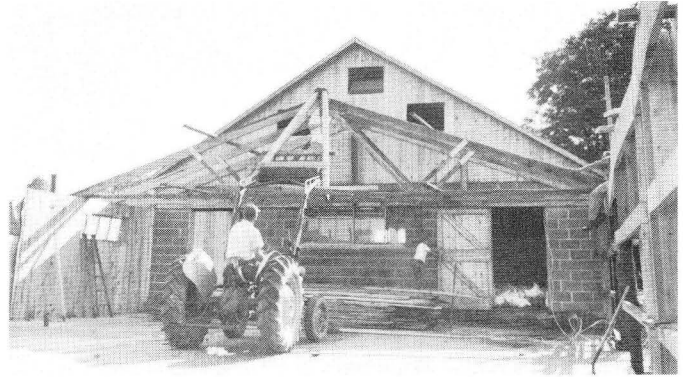

Fig. 17. A utility farm tractor and loader can be used for lifting trusses into place on a building as shown in this 36-foot-wide poultry house addition.



Fig. 18. Hoisting equipment may be needed to erect larger trusses on high sidewall buildings.

Fig. 19. The proper anchorage of the rafter supports, with scabs bolted in place, is important in pole frame buildings. All of the roof load is transferred to the sidewall poles in this case.

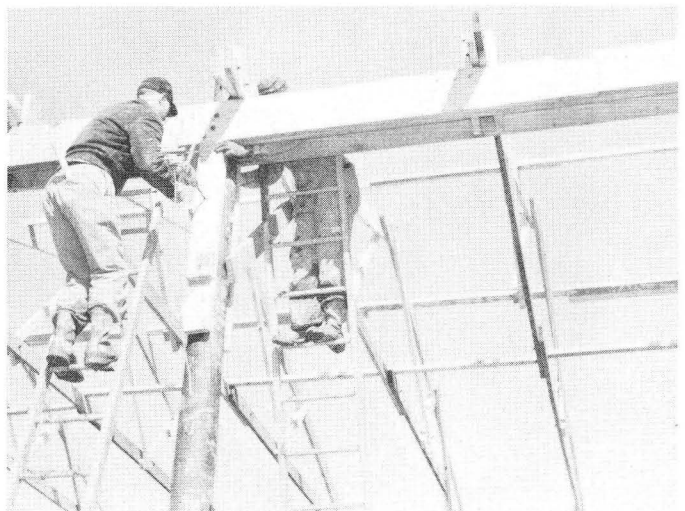

TABLE 1—Size of Rafter Supports Required for Clear-Span Pole-Type Buildings

Pole Spacing (In Feet)	Truss Spacing (In Feet and Inches)	Roof Girt Length (In Feet)	Size and Number of Rafter Supports on Each Side of Building			
			24'	30'	36'	40'
11'	3' 8"	12'	2—2" x 8"	1—2" x 8" 1—2" x 10"	2—2" x 10"	2—2" x 10"
12'	4' 0"	14'	1—2" x 8" 1—2" x 10"	2—2" x 10"	1—2" x 10" 1—2" x 12"	1—2" x 10" 1—2" x 12"
13'	4' 4"	14'	1—2" x 8" 1—2" x 10"	2—2" x 10"	1—2" x 10" 1—2" x 12"	2—2" x 12"
14'	4' 8"	16'	2—2" x 10"	1—2" x 10" 1—2" x 12"	2—2" x 12"	2—2" x 10" 1—2" x 12"
15'	3' 9"	16'	1—2" x 10" 1—2" x 12"	2—2" x 10" 1—2" x 12"	1—2" x 10" 2—2" x 12"	3—2" x 12"
16'	4' 0"	16'	2—2" x 12"	1—2" x 10" 2—2" x 12"	3—2" x 12"	These dimensions not recommended

4 feet 8 inches, the 2- by 4-inch purlins must be placed on edge. This is difficult since toenailing must be done very carefully to obtain good anchorage.

Apply metal roofing (Fig. 23) to the girt deck of the 2- by 4-inch members placed 2 feet on center.

Fig. 20. In pole construction, the trusses that are between the poles are anchored to the rafter-supporting members with vertical members.

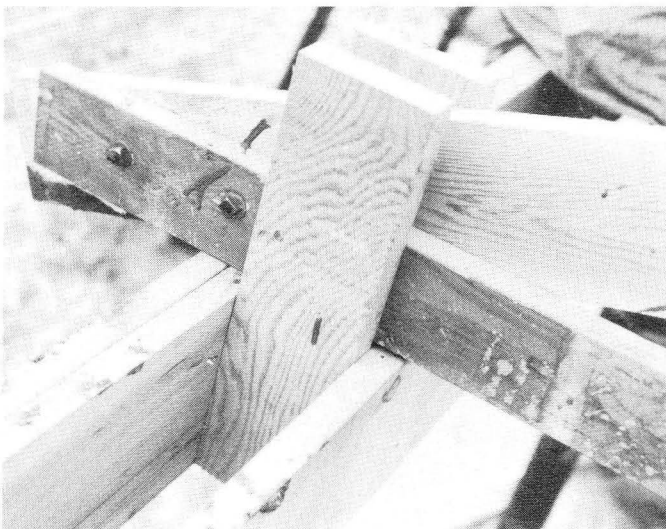

Plans

You can get detailed truss plans (Fig. 24) at very low cost from the county agricultural agent or Agricultural Engineering Department, Michigan State University. Plans are available for both ring-bolt and glue-nail trusses with roof slopes of 6 in 12 and 4 in 12; and for building widths of 24, 30, 36, and 40 feet.

Fig. 21. In frame construction, the trusses can be secured to the sidewall framing with Trip-L-Grip fasteners or strap iron.

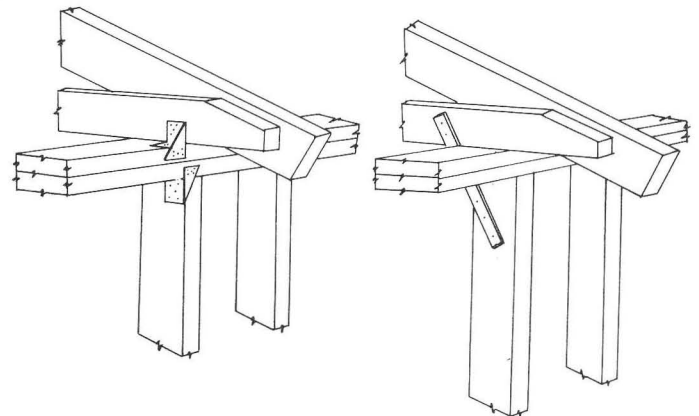

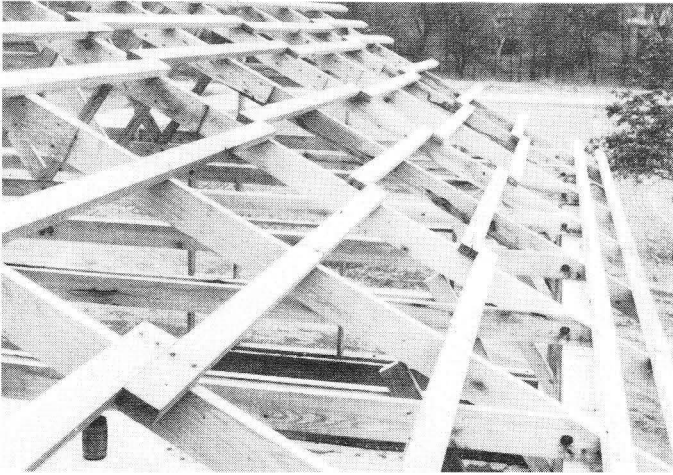

Fig. 22. Trusses spaced about 4 feet on center provide an economical framing for 2- by 4-inch girt-type deck and corrugated sheet metal roofing. The girts are placed 2 feet on center; where the supporting trusses or rafters are not more than 4 feet 8 inches on center, they can be applied in a flatwise position.

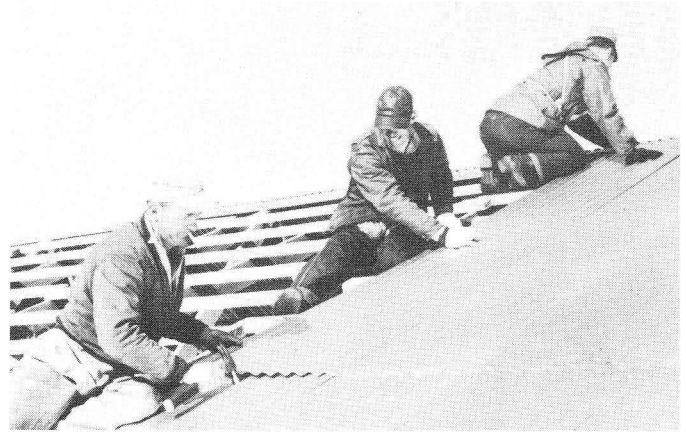

Fig. 23. Corrugated sheet metal roofing is easy to apply over the clear-span trusses and girt-type deck.

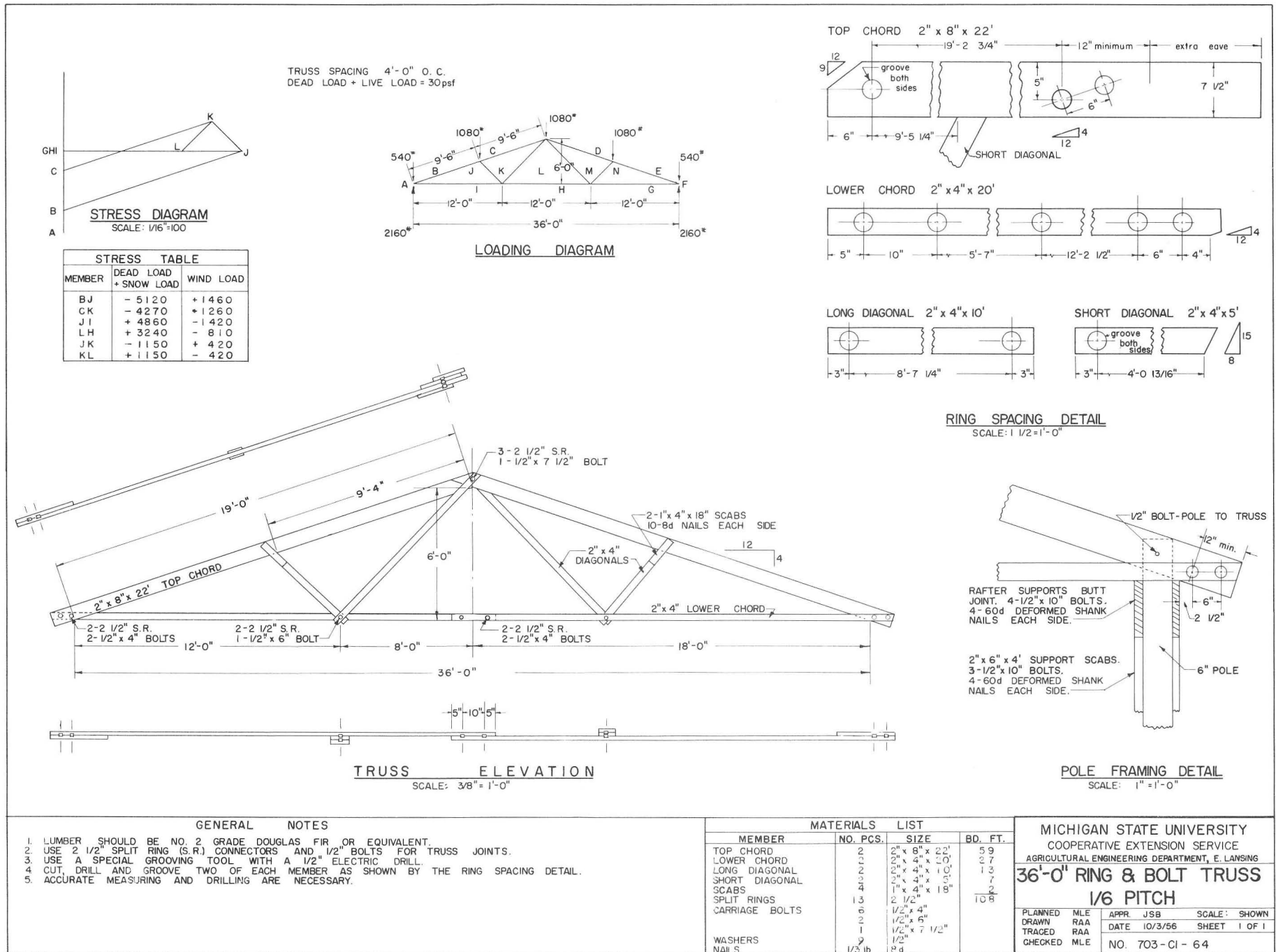

Fig. 24. This is a small-scale copy of one of the truss-plan working drawings. Notice the complete list of materials, stress tables, member cutting details and general specifications. All of the ring-bolt and glue-nail truss plans are similar to this sample plan.