

MICHIGAN BEEF PRODUCTION

COOPERATIVE EXTENSION SERVICE • MICHIGAN STATE UNIVERSITY

Fencing for Beef Cattle

*Lester A. Burdette, The Pennsylvania State University and
Kenneth R. Geuns, Michigan State University*

Fences are used to divide property and confine cattle. They should be carefully planned and properly constructed. The type of fence constructed will have a major influence on cost. The layout of your fences will influence the working efficiency of your farm. Many times fences are rebuilt in old locations when a new layout would improve working efficiency. Water and corral locations are major factors to consider in fence layouts. Gates located in or near fence corners make it easier to move cattle out of a field than gates in the middle of a line fence.

TYPES OF FENCES

Permanent fences can be constructed of woven wire, barbed wire, combinations of these or boards. Board fences being more expensive, are usually used only around the farmstead to improve its appearance or for corral fences. Woven wire fences are usually used in areas of high animal pressure or where sheep and cattle both use the same pastures. Barbed-wire fences will control cattle under most farm conditions.

Temporary fence is usually electric with one or two wires. Electric fences are best used to subdivide fields for better grazing management rather than as perimeter fences around the farm. Electric fence can be constructed on steel or wood posts with insulators or attached directly to fiber glass or plastic posts. Only fence chargers bearing the Underwriters Laboratory (U.L.) seal should be used. Electric fences can be relied

upon to give a powerful shock and deter animals. In addition, posts can be lighter and placed further apart. Furthermore, in some cases, the added costs of the energizer may be offset by savings in fence construction and maintenance.

CONSTRUCTION AND MATERIALS

Brush clearing and minor ground leveling makes fence building much easier, if the fence is not to be built on a cleared area.

A fence will only be as strong as the corners and braces. It will pay to build corners as strong as possible (See figures 1 & 2). Corners can be constructed with wood, concrete or special steel posts.

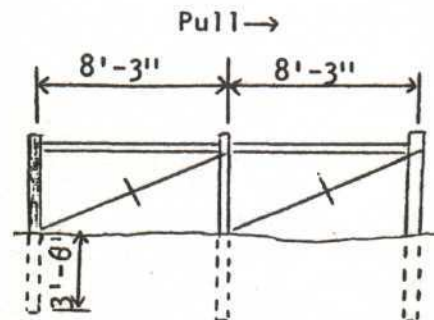

Fig. 1. Wood corner posts detail. Use 5-inch top posts. Double strand no. 9 wire used for wire bracing and 4" x 4" as horizontal brace.

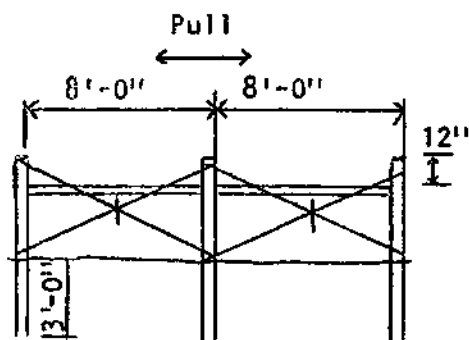

Fig. 2. Wood line pull brace. Use every 40 rods in long fences.

Wood Posts

These can be purchased in many localities at reasonable cost. Wood posts should be mostly heartwood since sapwood of most species will rot in 2 to 5 years. The preferred species of tree from which posts are cut are Osage Orange, Red Cedar and Black Locust. These will have life expectancy of about 25 years. If other species are used they should be treated to resist decay. Special methods are required to properly treat posts on the farm. Brushing on wood preservative is not recommended since the wood will not absorb enough preservative to give effective prevention against decay.

Pressure treated southern pine posts are available in most areas. If properly treated these posts have a life expectancy of at least 30 years.

Steel Posts

These have a number of advantages. They are lightweight, fireproof and easily driven into most soils. They offer the additional feature of grounding the fence against lightning when in contact with moist or wet soil.

In areas of high cattle pressure steel posts can be bent or forced out of line.

Setting Posts

Corner posts should be set about 3 to 3½ feet into the ground and brace posts at least 3 feet. Wood line posts are usually set 2 to 2½ feet in the ground and steel posts 1½ to 2 feet. The depth the posts are set in the ground and the height of the fence determine the length of the post needed.

Corners and braces will be stronger if a post hole is dug and the post set with well-tamped fill dirt or poured concrete. Line posts can be satisfactorily driven with a post driver mounted on a tractor.

Safety Precautions

Fence construction always involves the risks of injury. Follow these precautions:

- Wear heavy leather gloves, boots or high shoes, and tough, close-fitting clothing.
- Never use a tractor to stretch woven-wire or barbed-wire fencing. While up on the tractor you may not be able to tell when the fencing has been stretched to the breaking point. If the wire should break, you could be seriously injured by the recoil of the clamp bar, chain, or fencing.
- Carry staples, nails, or other fasteners in a metal container or in an apron—not on your person. Under no circumstances carry them in your mouth—a common, but extremely dangerous habit.
- When stretching woven wire or barbed wire, stand on the opposite side of the post from the wire and stretcher unit.
- If you handle preservative-treated posts, do not rub your hands or gloves on your face or other parts of your body. Some people are allergic to the chemical.

Attaching Fence

Be systematic when stringing wire. Always attach the top wire first when constructing a barbed-wire fence. Work from the top down. This will assure that all wires are of equal tension. Attach wire to the sides of the post nearest to the livestock being fenced, except when appearance is important.

Always drive staples at an angle to the posts. Staples should be a minimum of 1½ inches in length. Longer staples are necessary in soft wood posts. Driving staples tightly against the wire is a common mistake. This weakens the wire and does not allow the fence to expand and contract.

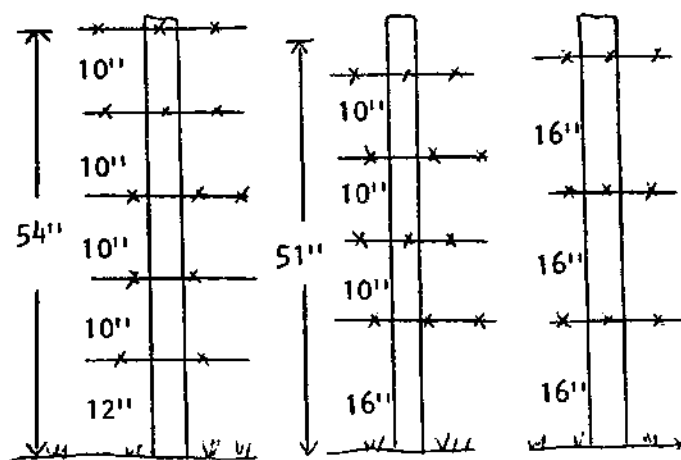

Fig. 3. Some typical barbed-wire spacings.

A COST COMPARISON OF DIFFERENT FENCE TYPES (1981 prices)

I. Description of Fence Types

Type of Wire		Post Spacing
A	4 strands barb	12 ft.
B	4 strands barb	16 ft.
C	5 strands barb	12 ft.
D	5 strands barb	16 ft.
E	35 inch woven, 2 top strands barb	14 ft.
F	35 inch woven, 2 top strands barb	16 ft.
Line fence stretching braces installed:		
level land — 1 brace each 40 rods		
hilly land — 1 brace each 20 rods		
G	4 strands barb, twisted stay each 10 ft.	50 ft.
H	4 strands barb, twisted stay each 10 ft.	100 ft.
Line fence stretching braces installed each 250 ft. for 50 ft. 50-ft. post spacing and each 400 ft. for 100-ft. post spacing.		

II. Fence Input Costs

Item	Cost
6½-ft. steel posts	\$ 2.65 ea.
8-ft. red cedar posts, delivered	\$ 3.93 ea.
Woven wire, 47 in.	\$99.00/20 rod roll
Barb wire, 12½ gage	\$34.00/80 rod roll
Twisted wire stays	\$29.00/100
Brace wire, #9	\$7.60/lb. roll
Staples	\$28.00/50 lb.
Labor	\$4.00/hr.
Post hole digging	\$0.40/hole
Tractor rental (no labor or fuel)	\$16.00/hr.
Electric fence energizer	\$250.00 ea.

III. Cost Summary

	Fence Type							
	A	B	C	D	E	F	G	H
	4 strands barb 12' posts	4 strands barb 16' posts	5 strands barb 12' posts	5 strands barb 16' posts	35" woven barb 14' posts	35" woven barb 16' posts	4 barbs 10' stays 50' posts	4 barbs 10' stays 50' posts
A. Initial Investment Cost/rod¹								
Materials	5.25	4.70	5.92	5.37	9.15	8.95	3.82	3.60
Machine Cost	.24	.20	.27	.23	.19	.18	.10	.08
Labor Cost	1.20	1.05	1.35	1.20	1.02	.96	.60	.57
Braces	.55	.55	.56	.56	.59	.59	.56	.35
Total Cost/rod	7.24	6.50	8.10	7.36	10.95	10.68	5.08	4.60
Total Cost/mile	2313.60	2080.00	2592.00	2355.20	3504.00	3417.60	1625.60	1472.00
Total Cost/foot	0.44	0.39	0.49	0.45	0.66	0.65	0.31	0.28
B. Annual Cost/rod²								
Non-cash (depreciation, interest on investment)	.78	.71	.88	.79	1.19	1.14	.54	.48
Cash (repairs)	.07	.06	.07	.07	.08	.08	.08	.11
Total Annual Cost/rod	.85	.77	.95	.86	1.27	1.22	.62	.59
Total Annual Cost/mile	272.00	246.40	304.00	275.20	406.40	390.40	198.40	188.80

¹Actual

²Estimated

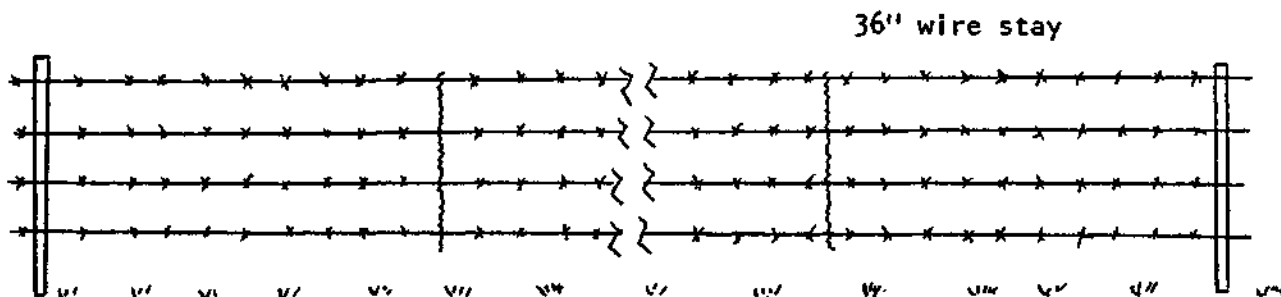

Fig. 4. Suspension fence construction. Posts up to 100 ft. apart. Twisted wire stays 10 to 15 ft. apart.

HIGH-TENSILE WIRE FENCE SYSTEM

Basically, this system consists of strands of smooth wire held in tension along pressure-treated wood posts. This system was introduced into the U.S. from Australia and New Zealand in the late 1970's.

High tensile fencing is very strong and has a long life expectancy. It also makes an attractive barrier and minimizes hide damage to livestock. The system has also been used in trellises for dwarf fruit trees and grape vines.

For livestock use, the wire spacing must be at a minimum to prevent animals from sticking their heads between the wires and pushing through. The fence may be electrified to insure that this does not happen.

For suitable fencing for feedlots or drylots, a total of 8 or 9 wires, of which three are electrified, are recommended. Use wood posts, set 16 to 60 feet apart. As the post spacing becomes wider, more droppers should be used (see Figure 1). The approximate cost of such a fence is currently about 45¢ per foot for the materials. This figure does not include labor charges for construction or the cost of the electric energizer.



Figure 1. This photo shows many of the components of an electrified high-tensile, smooth wire fence for a feedlot or a cow drylot: 9 wires with the 1st, 5th and 7th electrified (note wrap-around plastic insulators); 2 posts, 32-ft. spacing; 2 wooden droppers; 9 in-line strainers to tighten fence.

G MSU is an Affirmative Action/Equal Opportunity Institution. Cooperative Extension Service programs are open to all without regard to race, color, national origin, sex, or handicap.

Issued in furtherance of Cooperative Extension work in agriculture and home economics, acts of May 8, and June 30, 1914, in cooperation with the U.S. Department of Agriculture. W.J. Moline, Director, Cooperative Extension Service, Michigan State University, E. Lansing, MI 48824.

This information is for educational purposes only. Reference to commercial products or trade names does not imply endorsement by the Cooperative Extension Service or bias against those not mentioned. This bulletin becomes public property upon publication and may be reprinted verbatim as a separate or within another publication with credit to MSU. Reprinting cannot be used to endorse or advertise a commercial product or company.

2P-5M-3:87-Reprint-TCM-UP-Price 20¢, single copy free to Michigan residents.

FILE: 19.151

0-16832