

TURFGRASS TRENDS

Volume 7, Issue 5 • May 1998

TURF CHEMISTRY

Nitrogen Fertilization Reconsidered

Richard J. Hull, University of Rhode Island

The use of nitrogen fertilizers in turf management continues to generate controversy and debate. This in spite of the fact that few practices are more widespread or better grounded in agronomic science. One factor which has prompted concern over nitrogen use is the perception that nitrate leaching from turf is a significant contributor to nitrate pollution of ground water. This concern is fueled by reports such as one published recently in which a model was generated to evaluate nitrate loading into estuarine coastal waters (Valiela et al. 1997). This model assumed that 61% of nitrogen applied to turf was ultimately discharged into ground water. It treats nitrogen applied to turf exactly as that used on agricultural lands except there the portion of nitrogen removed in a crop is subtracted. The only other nitrogen losses from turf considered by the authors of this model were gaseous losses which they pegged at 39% of nitrogen applied. The possibility that nitrogen might be accumulating within a turf-soil ecosystem was apparently not considered.

The substantial amount of research on nitrate leaching from turf which was reviewed by Marty Petrovic at Cornell University (1990) apparently was not seriously evaluated in constructing this model. Also not considered was the analysis which we presented a few years ago within these pages (Hull 1995) nor the comprehensive review of water quality impacts by golf course management recently reviewed by Cohen et al. (1997). All of these reports indicate that when reasonable management practices are employed, very little nitrate leaches from a healthy turfgrass sod. For reasons that will be considered later, it is probably safe to assume that no amount of research will convince some that nitrogen

FIGURE 1. NITROGEN BUDGET FOR COOL-SEASON TURF*

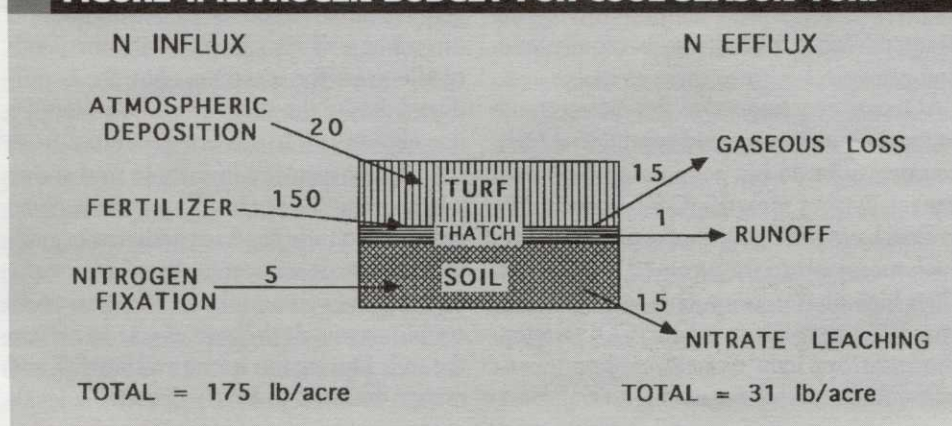

* Cool-season turfgrasses fertilized annually with 3.5 lbs. N/1,000 sq. ft. Numbers in lbs. per acre per year.

IN THIS ISSUE

■ Nitrogen Fertilization Reconsidered1

- Why Does Turf Require N Nitrogen Use Efficiency
- Nitrogen Gains and Losses
- How Much N Is In Turf?
- Which Sources Are Best?
- How Little N Is Enough?
- Prospects for the Future

■ Current Status of U.S. Turfgrass Pathology Research .10

- Historical Development
- Research Emphasized Chemical Control
- 1980s Marks Change in Research Direction
- Recent Developments
- Cultural Practices and Turfgrass Diseases

Editor

Terry McIver
440-891-2709; 440-891-2675 (fax)
turfgrasstrends@advanstar.com

Production Manager

Karen Lenzen
218-723-9129; 218-723-9576 (fax)
klenzen@advanstar.com

Circulation Manager

Frank Christopherson
218-723-9271

Layout & Production

Bruce F. Shank, BioCOM
805-274-0321

Group Editor

Vern Henry

Group Publisher

John D. Payne
440-891-2786; 440-891-2675 (fax)
jpayne@advanstar.com

Corporate Office

7500 Old Oak Blvd.
Cleveland, OH 44130-3369

Editorial Office

7500 Old Oak Blvd.
Cleveland, OH 44130

Abstracts: 800-466-8443
Reprint: 440-891-2744
Permission: 440-891-2742
Single copy or back issues:
Subscription/Customer Service
218-723-9477; 218-723-9437 (fax)

**Chairman and Chief Executive Officer**

Robert L. Krakoff

Vice Chairman

James M. Alic

Vice President, Business Development

Skip Farber

**Executive Vice Presidents**

William J. Cooke, Alexander S. DeBarr, Glenn A. Rogers

VP-Finance, CFO & Secretary

David J. Montgomery

Treasurer and Controller

Adele D. Hartwick

applied to turf does not ultimately represent a problem for ground water quality. Therefore, it may be constructive to reconsider nitrogen fertilization of turf in the light of these lingering concerns and some recent research findings.

Why does turf require fertilizer nitrogen?

When you think about it, this is a valid question. Every turf manager and home owner can attest to the fact that unfertilized turf soon loses its green color, suffers a loss of stand density and becomes invaded by weeds. Yet, it is not at all obvious why this happens.

N availability and demand. After several years of measuring the nitrate content of soil water that had leached from the root zone of established turf stands, it became apparent that one reason turf requires fertilizer nitrogen is a matter of timing. Throughout the fall and winter soil nitrate levels gradually decline until they reach a low during March and April (Fig. 1). That is the time when grass begins to grow and experiences a sharp increase in its need for nitrogen. This early in the spring, however, the soil remains cold and mineralization of soil organic nitrogen is slow. Thus, the soil water nitrate content drops to its lowest level and, if no fertilizer is applied, deficiency symptoms will be observed. That is why turf often appears hungriest during mid- to late-spring. As the soil warms during May and June, mineralization of organic nitrogen and ammonium oxidation to nitrate occurs more rapidly and soil nitrogen becomes more available.

Grasses may respond to this nitrogen and enter the summer in good condition if high temperatures do not suppress turf growth especially root growth. Cool-season turfgrasses have a difficult time coping with the high temperatures of summer. Because of their high photorespiration which markedly reduces net photosynthetic CO₂ fixation during strong light and elevated temperatures, these grasses are unable to transport

much energy in the form of sugars to the roots. This causes the roots to decline which further stresses the grass because water and nutrients are not absorbed efficiently. A downward spiral occurs with respect to root condition and in many years can result in 75% of a turf root system being lost. Add to this predation of soil insects (grubs, nematodes) and your turf can lose almost all of its functioning roots by the end of the summer.

During this root decline, soil microorganisms are mineralizing organic nitrogen which ultimately is released to the soil solution as nitrate. If turf roots are unable to absorb much nitrate (remember nitrate absorption is a metabolically active process), it will accumulate in the soil and leach out of the root zone whenever rain or irrigation are sufficient to permit water to percolate through the soil profile. This can be seen in Fig. 1 during late spring and again in late summer. During this year (1996) there was a succession of several very hot days during late May. The sudden high temperatures shocked the turf probably causing substantial root decline and soil water nitrate levels increased to about 8 ppm. The remainder of the summer was cooler than normal which allowed the turfgrass root system to recover and bring the nitrate levels down. This was unusual because normally once the soil nitrate level increases during the summer it remains high until late fall or winter. September brought a return to hotter than normal temperatures and excess precipitation which allowed nitrate to accumulate again to about 8.5 ppm.

In short, the ability of soils to make nitrogen available to cool-season turfgrasses is often not well coordinated with the needs of the grass for nitrogen. Nitrate is produced during the summer when grasses are less able to use it and not generated from soil organic nitrogen in early to mid-spring when grass demands are greatest. Even unfertilized turf (Fig. 1) experienced a gradual increase in soil water nitrate during the summer because uptake by the grass roots could not match the rate of release within the soil. During the spring and late fall, soil nitrate declined to barely detectable levels

FIGURE 2. VARIATION IN SOIL WATER NITRATE LEVELS FROM FERTILIZED AND UNFERTILIZED TURF

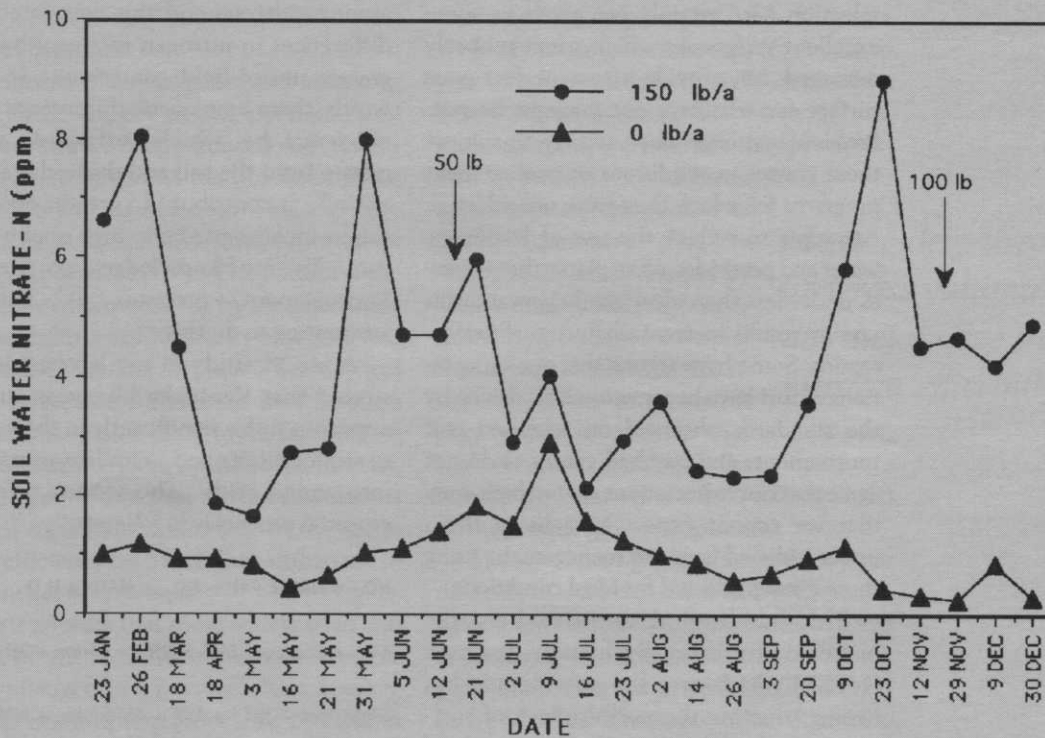

because root uptake was occurring and soil mineralization was less active in cold soils. These results demonstrate that the availability of soil nitrate to turf and the ability of grass roots to absorb it are influenced by many distinct factors which only occasionally coincide so as to bring about efficient nitrogen use.

Nitrogen use efficiency

As will be explained later, no more than 20% of fertilizer nitrogen is probably lost from a well managed turf so why must it be applied every year to maintain turf quality? The answer to this question is complex and there is still much to be learned about the dynamics of nitrogen in a turf-soil environment. However, we think there is enough information to provide at least some partial answers. Nitrogen availability comes down to a matter of matching turfgrass needs with the soil's ability to meet those needs and the inherent efficiency of turfgrasses to obtain

and utilize nitrogen from the soil.

We might start with the latter consideration of nitrogen use efficiency by turfgrasses. How efficient are turfgrasses in obtaining nitrogen released by the soil? A superficial analysis indicates that most commonly utilized turfgrass cultivars are not very efficient. This is not surprising if we consider the origins of most turfgrasses currently used on golf courses, athletic fields and home lawns. These grasses were selected by turfgrass breeders based on their color, stand density, fineness of leaf, seedling vigor, seed yields and disease resistance. Nowhere in these selection criteria is there a factor that could be linked with nutrient use efficiency. In fact, most turfgrass selection trials are conducted on good well fertilized and irrigated soils. Turfgrasses are evaluated for their performance under near ideal conditions, those that might be provided on a golf course or carefully managed lawn during a good year.

There is nothing wrong with this basis for

selection. It certainly has given us some excellent turfgrasses which when properly managed, can provide a near perfect grass surface for whatever use it might be put. Problems emerge when we try to subject these grasses to conditions or management programs for which they were not selected. Attempts to reduce the use of fertilizers, water and pesticides, often places these grasses under less than ideal conditions and this usually results in unsatisfactory turf performance. Some have argued that our expectations of turf have become too high driven by the standards observed on televised golf tournaments and baseball games. I do not agree that our expectations are too high, only that we cannot expect to achieve them under reduced levels of management using those grasses selected for ideal conditions.

This has been demonstrated by the National Turfgrass Evaluation Program (NTEP) which over the past decade has been evaluating the performance of turfgrasses under both high and low levels of fertility, irrigation, etc. In general, those grasses that perform well under reduced management are not the same cultivars that score highly under intensive management. This is not surprising and it is encouraging in that it shows turfgrasses can be selected for superior performance under less than perfect conditions. For some time, several turfgrass improvement programs have been seeking grass selections that perform well under minimum management. Old cemeteries, municipal parks and roadsides are popular places to search for grasses that exhibit good turf qualities under conditions of virtual neglect. I doubt if many of these selections have been released as fine turfgrass cultivars but that germplasm is out there and it can provide the foundation for high quality but low maintenance grasses.

We have compared cultivars from diverse genetic backgrounds of several turfgrass species for their efficiency in nitrate uptake and highly significant differences were often found (Liu et al. 1997; Hull and Liu 1995). Both the capacity for uptake and the root's affinity for nitrate (ability to absorb from low concentrations) differed

among cultivars and this correlated with differences in nitrogen recovery by these grasses under field conditions. In other words, there are genetic differences in the efficiency by which turfgrasses absorb nitrate from the soil and those characteristics which contribute to greater efficiency can be incorporated into high quality cultivars. To my knowledge, no turfgrass improvement program is currently attempting to do this.

A recent study in my lab has demonstrated that Kentucky bluegrass cultivars appear to differ significantly in their ability to reduce nitrate and assimilate ammonium into amino acids. The sequence for this essential process is as follows:

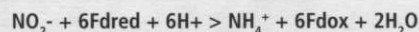
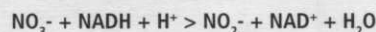

Here nitrate gains two electrons from NADH and is reduced to nitrite. This reaction occurs in the cytosol of root or leaf cells. Next, nitrite enters plastids (chloroplasts in leaf cells) and is reduced to ammonium by gaining six electrons from reduced ferredoxin. In leaves, this is a photosynthetic reaction. Finally, ammonium is assimilated with glutamic acid to form the amino acid glutamine. This last step also occurs in plastids and requires an ATP to activate the glutamate molecule. Glutamine can be incorporated into the primary structure of proteins and it can serve directly or indirectly as the nitrogen source for all other amino acids.

Our preliminary results indicate that most nitrate is reduced and assimilated in leaves of Kentucky bluegrass with roots playing a minor role. When nitrate is reduced in leaves, it stimulates shoot growth at the expense of root growth. This is fine for field crops but is not so good for a closely mowed turfgrass. If nitrate is reduced and assimilated into glutamine in the roots, it promotes the growth of roots equally or maybe more than shoots. This

would be a good thing for turfgrasses because a more extensive root system and a slower shoot growth rate would generally make grasses better adapted to close mowing and heavy use.

Kentucky bluegrass genotypes appear to differ with respect to the percentage of absorbed nitrate that is reduced within their root system but most tend to favor shoot reduction and assimilation. This was confirmed in an imaginative study reported by Bertauski et al. (1997). They studied the efficiency of nitrogen use by six genetically diverse cultivars of Kentucky bluegrass and concluded that over all plant efficiency was more related to differences in utilization within the plant than to differences in uptake characteristics by the roots. In short, it is highly likely that turfgrass cultivars exhibit significant differences in the metabolic efficiency by which they utilize nitrogen once it is absorbed.

So it appears that most widely used cultivars of grass species do not metabolize their nitrogen in a very efficient manner. This is not surprising because turfgrasses have never been selected for such characteristics. Choosing the greenest grass when it is given high rates of nitrogen fertilizers will not identify those grasses which are most efficient in utilizing nitrogen when it is scarce. A major reason why turf requires annual applications of nitrogen is because it is not very efficient in using available nitrogen especially when the supply is low.

Poor nitrogen use efficiency is not generally characteristic of grasslands, just the opposite. Some of the world's most productive plant communities are dominated by grasses. The short and tall grass prairies of the American great plains supported vast populations of bison with very little annual nitrogen addition. Such grasslands obviously did not become nitrogen deficient because no one was fertilizing them. Those grasses were efficient users of available nitrogen and their needs were coordinated with the ability of the soil to make nitrogen available to them. Obviously turfgrasses are not so well coordinated with their soil environment.

Nitrogen gains and losses

Besides fertilizer, turf receives nitrogen

from atmospheric deposition (both wet and dry) and associative nitrogen fixation in the soil. Data on these sources of nitrogen are scarce and can only be estimated. They also are likely to vary considerably from year to year so a firm value is virtually impossible. Based on total nitrogen content of rain water samples, we estimate that precipitation annually contributes approximately ten pounds of nitrogen per acre. For the nitrogen model presented by Valiela et al. (1997) dry deposition is considered to equal that of wet deposition. Lacking any better estimates, it may be safe to consider that turf receives about 20 lbs N/acre per year (0.46 lbs N/1000 sq-ft) through atmospheric deposition.

Biological nitrogen fixation is even more difficult to estimate for a turf-soil ecosystem. I am familiar with no measurements of nitrogen fixation in a turf soil. Such probably occurs but it would be from free-living associative bacteria rather than from symbiotic root nodulating organisms. Only if white clover or other legumes are a prominent part of the turf sod, would symbiotic nitrogen fixation be significant. The relatively high nitrate levels present in turf soils during much of the time when soils are warm (Fig. 1) would tend to depress nitrogen fixation because this process is inhibited by elevated soil concentrations of inorganic nitrogen. For the above reasons, it is difficult to believe that nitrogen fixation could contribute more than 5 lbs N/acre/year (0.1 lb N/1000 sq-ft).

Clipping retention on turf does not constitute a nitrogen gain, only not a loss. Turf definitely benefits from clipping retention. Starr and DeRoo (1981) estimated that about one-third of the nitrogen used by turf each year is derived from clippings. Obviously if clippings are removed, annual fertilizer nitrogen use should be increased by one-third. To achieve a high nitrogen use efficiency by turf, clippings should not be removed.

For managed turf, annual fertilizer nitrogen application constitutes about 3.5 lbs N/1000 sq-ft/year (150 lbs/acre). This value varies a good deal depending on the

Most widely-used turfgrass cultivars do not metabolize their nitrogen efficiently.

intensity of turf maintenance. However, it has also declined considerably during the past four decades. When I first started working with turf in 1969, annual rates of lawn fertilization in the Northeast often exceeded 6 to 7 lbs N/1000 sq-ft. Of course, fewer lawns were fertilized at all during the 1960s. Since then, annual nitrogen applications have declined to about 3 lbs/1000 sq-ft or less. This is partly due to a greater sensitivity to over fertilization to avoid water pollution and to be more environmentally responsible. Better management practices have also contributed to less nitrogen use. Greater reliance on fall fertilization, increased use of controlled release materials and the introduction of more responsive turfgrasses have all contributed to lower fertilizer rates.

Nitrogen losses from turf apparently are not great based on the considerable research cited earlier. The equivalent of 75% of nitrogen applied as fertilizer can be removed in clippings. If clippings are not removed or if they are composted and returned as a top-dressing, this loss does not occur. Gaseous losses are probably nothing like the 39% employed in the Valiela model. Under highly promotive conditions, substantial fertilizer nitrogen can be lost through ammonia volatilization and prolonged soil saturation can cause significant denitrification losses as N_2 or N_2O , but such conditions normally are transitory on well drained turf sites. Even on heavy soils, a well established turf promotes water percolation and shortens the duration of water logged conditions. Thus, a more realistic estimate of gaseous nitrogen losses from turf is no more than 10% of that applied as fertilizer (~0.3 lbs/1000 sq-ft). Leaching also accounts for more like 10% of nitrogen applied, often probably less. Because turfgrasses facilitate soil infiltration, runoff is rarely encountered from an established sod except in those situations where a heavy soil combines with excessive rainfall to permit surface flow. Even in such locations, these events are not common and the amount of nitrogen lost is small.

Based on the foregoing discussion, it is

possible to construct a reasonable nitrogen budget for lawn turf (Fig. 2). A putting green would be somewhat different. This budget indicates that a fertilized lawn would receive a total of 175 lbs N/acre/year and, if clippings are retained, lose about 31 lbs N/acre/year. It is this vast disparity between nitrogen input and measurable output that makes many ecologists assume nitrogen losses must be much greater than those reported by turf agronomists. It also appears that if nitrogen fertilizers were not applied at all, natural nitrogen inputs from atmospheric deposition and nitrogen fixation would just about match measured losses due to gaseous emissions, leaching and runoff. In short, it should be possible to maintain a healthy turf without adding any nitrogen as fertilizer.

How much nitrogen is in turf?

Obviously turfgrasses need nitrogen so there must be a supply of it in a turf/soil system that can become available to the grass. The question then centers on how much nitrogen is actually present and how much should be there to meet turf needs. We conducted a comprehensive analysis of the total nitrogen content of a long established turf that had been managed at moderate intensity for ten years (Hull and Liu 1995; Hull 1994). The total nitrogen recovered averaged 2,165 lbs/acre (~50 lbs/1000 sq-ft). Of this nitrogen, 83% was present as soil organic matter the remaining 17% as thatch and living grass plants. The 1,800 lb N/acre of soil organic nitrogen had accumulated over a period of many years and constitutes nitrogen applied as fertilizer that was essentially fixed within the turf/soil system.

These values are in agreement with findings of Porter et al. (1980) who sampled 100 turfgrass locations on Long Island, New York ranging in age from 1 year to 125 years. Their analysis of turf age versus soil nitrogen content indicated that ten year old turf normally contained about 1,768 lbs N/acre which is very close to our 1,800

lbs/acre. Porter's study contained very few soil samples from turf older than 25 years (17 of 100) so his conclusion that turf soils plateau at about 2,210 lbs N/acre is based on a very limited data base. The fact that he sampled some sites which contained about 4,000 lbs N/acre indicates that the capacity exists for soils under turf to accumulate substantial amounts of nitrogen.

This gets to the heart of the assumptions made in the Valiela model (Valiela et al. 1997). They apparently rejected the notion that the turf/soil ecosystem possessed any real capacity for long term nitrogen storage. Therefore, any nitrogen applied that was not lost to volatilization or denitrification must be lost via the only remaining route known to occur, leaching. I suppose this is how they derived their estimate that 61% of fertilizer nitrogen leached as nitrate into ground water. It seems to me that the available data, of which there is not a lot, just as easily justifies the conclusion that the turf/soil ecosystem is a large sink for nitrogen and can accumulate relatively large amounts before it becomes leaky and discharges nitrate into ground water at rates close to the rate of application. Admittedly this says nothing about the stability of nitrogen in this system. Should the turf be killed or the soil used for some other purpose, much of this accumulated nitrogen probably would be mineralize and leach as nitrate. However, as long as the turf is maintained in a healthy vigorous condition, its ability to store nitrogen could be preserved for a long time.

Again a comparison with the native grasslands of the great plains might be justified. These grass/soil ecosystems accumulated vast amounts of soil organic nitrogen producing soils many meters deep. Commercial agriculture has been exploiting these soils to this day. While we do not know how much nitrogen leached from such soils when the sod was removed and crops were planted, it obviously was not so much as to render the soils infertile. Now I am not suggesting that a closely mowed turf is analogous to the prairie grasslands but it is not too much of a stretch to believe that some of the same nitrogen recovery and retention processes may be occurring. At the very least, it is every bit as reasonable to

assume that turf can accumulate and hold substantial amounts of nitrogen as it is to believe that every pound of nitrogen applied equals 0.6 pounds leached as nitrate into ground water.

Minimizing turf nitrogen needs. If the efficiency of nitrogen use by turf is limited by the timing between soil release and turf needs and by some inherent defects in the position and characteristics of nitrate reduction, assimilation and metabolism, there should be ways by which such problems can be solved. This is not trivial because, given the amount of nitrogen stored in a turf/soil ecosystem, it should be possible to manage high quality turf with no application of fertilized nitrogen. For example, if only 5% of the 1800 lbs of soil organic nitrogen present in our turf soil was mineralized in a year, about 90 lbs of nitrogen per acre would be made available to the turf. Add to that 25 lbs of natural nitrogen deposition and fixation and approximately 45 lbs recycled through retained clippings and turf should have about 160 lbs of nitrogen available each year without any fertilizer additions. That should be enough to maintain a good turfgrass stand.

If sufficient nitrogen is present in a well established turf, how can we get around the inherent inefficiency problems cited above? The absorption and metabolism problems obviously will require a genetic solution which will be considered later.

However, the timing of nitrogen supply and turf need can be addressed partially through management. Both approaches to the problem must be taken but until nitrogen efficient grasses are made available, the turf manager must rely on cultural modifications. What follows are a few suggestions that result from the above discussion.

Some of these ideas will require additional research to confirm their value but I present them here for your consideration.

Seasonal timing of N application.

Because there is normally abundant nitrate in the soil solution during the fall and early winter, it would follow that fall

Given the amount of N stored in a turf/soil ecosystem, it should be possible to manage high quality turf with no application of nitrogen fertilizer.

fertilization should have little value. This does not agree with experience but it may make some sense all the same. Turfgrasses absorb nitrate throughout the fall and winter so long as the soil is not frozen. A late fall application of nitrogen, especially as a controlled release material, will be absorbed, stored as protein or nitrate and used to push early greening in the spring. The question may be how much is enough to give this spring response. I suspect that one-half to two-thirds of an annual application is too much and that about 0.5-1.0 lbs N/1000 sq-ft applied in late fall would be enough.

Must turf managers have observed that turf seems to respond to a light nitrogen application during late summer when the hot weather is over. This would make no sense if soil water nitrate levels are 5 ppm or higher. However, it may be a problem of position. The soil water could have 100 ppm nitrogen but it would do the turf little good if there were no live roots deep enough to reach it. I suspect that may be the problem for turf after a tough summer. The roots may have been so decimated by the rigors of summer that very few living roots are available to tap the abundant nitrate within the soil. Most of the turf root system must be regenerated from crown tissues and the new roots will initially grow in thatch and the upper most soil layer which may be leached of free nitrate. Thus, a light application of soluble nitrogen applied at the time of root regeneration could be highly beneficial. Once turf roots reach the abundant nitrate in the soil solution, it will be off and running and will require no additional nitrogen until late fall or spring.

Early fall nitrogen additions are a waste of time and money. The turf has more nitrogen than it can handle and it should have enough roots drawing that nitrogen to meet its needs for some time. Additional nitrogen applied at that time would do no good.

Early spring nitrogen applications would appear to make good sense. Adding nitrogen just as the turf root system has become well established and soil nitrate levels have

declined to inadequate levels (~early April in Fig. 1) would keep root development on track without stimulating excess leaf growth. Care must be taken not to discourage deep rooting in the spring by allowing nitrogen levels to become excessive. Two or more light applications (~0.5 lb/1000 sq-ft) at this time might be better than a single larger treatment. During late spring, another light application might be useful to help the grass face the hot weather with adequate nitrogen supplies.

Which nitrogen sources are best?

There are many diverse nitrogen sources available to the turf manager. Dr. John Roberts at the University of New Hampshire recently published a summary of various product lines available for turf and some guidelines for their use (Roberts 1998).

For fall and late spring applications, a controlled release material would be better than a readily soluble source. You want the nitrogen to be metered out over a period of weeks not, at least in the spring, to promote a flush of top growth. A material that does not depend on microbial degradation (e.g. IBDU) would be better at this time than one which is virtually inert in a cold soil.

Composts and other soil conditioners can be used with little regard for their nitrogen content. While such materials will contain about 3% nitrogen, most of it is bound into organic matter and will be released very slowly, much like soil organic nitrogen. The value of these materials is to promote thatch degradation, remove irregularities in the turf surface and promote vigorous shallow rooting (not at the expense of deep rooting) which will stabilize the turf and make it better able to derive nutrients from decomposing thatch and clippings.

I would avoid nitrate sources. They are simply too available and free to leach. While no soluble nitrogen source should be applied just before a heavy rain or deep irrigation, these events can not always be controlled. It just makes sense to but a little chemistry between the nitrogen source and

the nitrate it will eventually become. Even ammonium salts must first be nitrified in the soil before they can leach as nitrate. Urea also must be hydrolyzed before it can be oxidized to nitrate which buffers its vulnerability to leaching.

Foliar applications of liquid formulations are popular with lawn care companies because of ease and speed of application. Some argue that such applications promote foliar absorption and thus a more rapid response. I have seen no research which would support this contention and I am not sure a rapid response is often needed or desired. Foliar applications of urea are subject to ammonium volatilization which is nitrogen wasted. If a liquid application is made, follow it with a light irrigation to wash the nitrogen off leaves and into the soil, or at least the deeper thatch, where it is more likely to be utilized and not lost.

How little nitrogen is enough?

First, it must be remembered that a minimum nitrogen program is based on the assumption that there is already substantial nitrogen present as organic matter in the soil. This will only be true for older well established turf which has been managed reasonably for some time. A newly established turf will require a period of traditional management (about 10 years) before it will be ready for minimum nitrogen maintenance. A soil test for soil organic matter or total soil nitrogen will give you an indication of the soil's nitrogen status.

The secret to minimum nitrogen management of turf is to capitalize on the nitrogen already present and use fertilizer to fill in the gaps caused by uncoordinated supply and demand. The ideal method would be to monitor your soil water nitrate content and apply fertilizer nitrogen only when these values are low. The development of small unobtrusive suction lysimeters and portable nitrate assay kits may make this level of surveillance practical for turf managers within the near future. In general early and late spring, late summer and late fall are the times for greatest vigilance. However, as was evident in Fig. 1, local weather variations can influence the ability

of soil to release nitrogen and the turf's ability to use it.

A companion strategy for minimum nitrogen use is a reduction in nitrogen loss. We have discussed this before (Hull 1994) but being sensitive to the role that excess irrigation and turf injury due to disease, insects or traffic can have on nitrate leaching or gaseous losses will help maintain a tight nitrogen budget for your turf. Irrigating on an as needed basis allowing for modest drought stress to promote deeper rooting will help to conserve nitrogen at a time when leaching potential is great. Prolonged periods of a water-logged root zone will not only promote denitrification losses of nitrogen but will hasten the decline of the turf root system. Controlled irrigation and good internal drainage will contribute to greater nitrogen economy.

As mentioned above, high temperature within the grass canopy is a serious environmental stress to cool-season grasses. Warm-season grasses do not face this problem and consequently do not suffer the summer root decline observed in most cool-season species. Keeping grass cool is an impossible task during a heat wave. However, syringing during mid-day, maintaining adequate soil moisture levels, promoting deep rooting and where possible establishing landscape features (trees) to provide mid-afternoon shade on sensitive turf areas all will help. Mid-summer nitrogen applications will aggravate root destruction and actually contribute to greater losses. Insuring adequate phosphorous and potassium levels within the root zone will offer some protection and help slow root decline. Controlling root-feeding insects is a must if a low nitrogen program is being utilized. Hopefully a spectrum of effective biological insect management tools will soon be available since some are already beginning to appear (Villani 1995).

What is a realistic target?

Eventually fertilizer nitrogen on mature turf may be eliminated altogether. Today that is not practical but one pound of nitrogen per thousand (50 lbs/acre) as a

Newly established turf will require a period of traditional management (about 10 years) before it will be ready for minimum nitrogen maintenance.

Unfortunately, there appears to be little support for turfgrass research to study nutrient use efficiency

goal should be attainable. No two sites are identical and the manager will have to decide how little nitrogen is too little. I am encouraged by the testimony of turf managers who hear me talk on this subject and latter tell me that they have been maintaining turf at a one pound rate for years. They obviously have evolved these ideas from their own observations and experience and developed a minimum nitrogen program on their own. Such a program will not only provide a good quality turf but will reduce the management budget and virtually eliminate nitrate leaching.

Prospects for the Future

What I have tried to describe above might be viewed as a systems approach to turf fertilization. Essentially it involves taking all environmental and biological factors that influence nutrient use by turf into account while developing a nutrient management program. This I have attempted to do. Obviously refinements can be made and even greater efficiencies may be possible. However, a total elimination of fertilizer requirements will depend on the development of grass cultivars which are inherently more efficient in their use of nitrogen and other nutrients.

I wish I could say that good progress is being made along this front but unfortunately nutrient efficiency appears to remain a secondary consideration in most turfgrass breeding programs, both commercial and university based. I am not a plant breeder and I am not privy to inside information regarding the objectives of breeding programs. Thus, there could be a good deal more activity in this area than one can gather from technical reports and scientific meetings. However, I believe there are more fundamental reasons for a lack of progress in breeding nutrient efficient grasses than a lack of desire to do so. The desire may very well be there but the knowledge on how to

proceed is likely deficient. Before a breeding program can generate nitrogen efficient grasses, the breeders must understand the physiology behind nitrogen efficiency. I have sketched out a few concepts here but there is much more to learn. Unfortunately there appears to be little support for turfgrass research to study nutrient use efficiency. This is not only true for the US but throughout the world based on opinions I heard expressed at the International Turfgrass Research Conference last summer. Nutrient use efficiency is a long-term effort but most organizations that support turf research are more interested in immediate problems which are amenable to a quick fix.

I believe the prospects for nutrient efficient turfgrasses are bright but only if an appropriate investment is made. What can the turf manager do? Urge your local grower or management association to put some of its research funding into more basic research directed toward understanding nutrient use efficiency. If the local turf organizations recognize the value of such research, perhaps the national organizations will as well. Urge the National Turfgrass Evaluation Program to put some effort into evaluating turfgrasses for their basic nutrient efficiency characteristics. That program is very well situated to do undertake such an effort. This would not have to be repeated at different locations all across the country, one good lab could do it. Such research would identify how much variation currently exists among grass genotypes for various efficiency factors. It could also indicate where grasses are already efficient and where there is room for improvement. We are fortunate in that the technology exists for replacing an inefficient trait with one of greater efficiency from virtually any known organism. Thus, we know how to make more efficient grasses we just need to learn exactly what must be changed to increase their efficiency. As the ultimate consumers of turfgrasses, you have the greatest stake in this effort.