

# SPARTAN ENGINEER

MARCH, 1967



FEATURE ARTICLE:  
**FROM THE  
OTHER EDGE**

Don't be pigeonholed till you've had a chance to fly

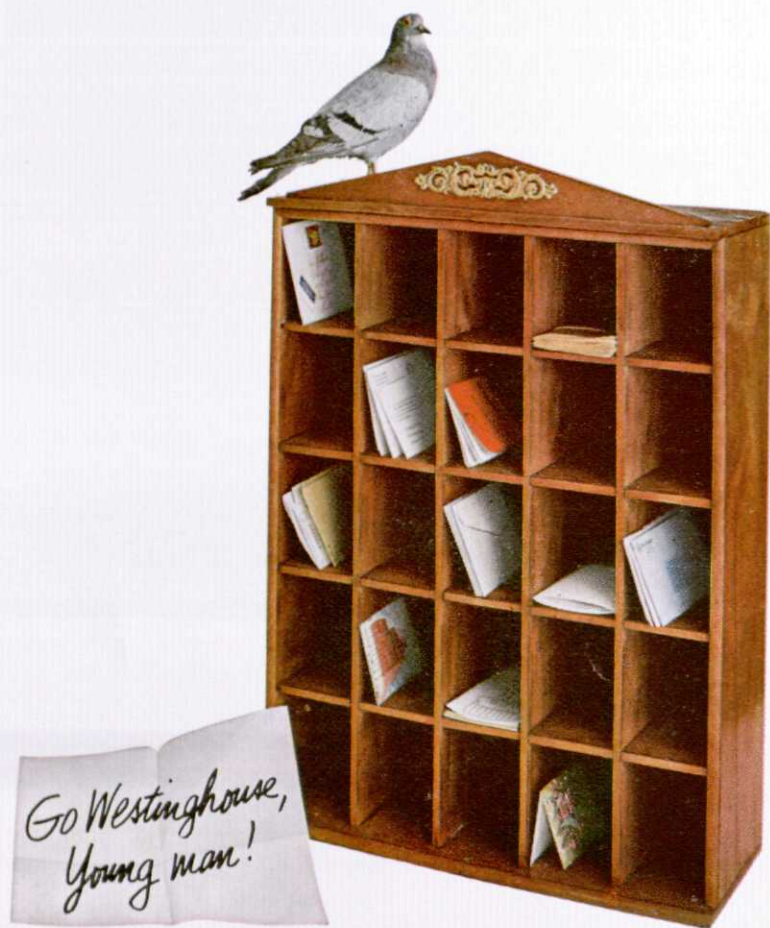

Why settle for a limited choice of opportunity in your field when you can choose from the whole world of industry at Westinghouse? No matter what you like to do, you're likely to do it better here.

And if at first you don't find your niche in one of our six operating groups,\* there's a good chance you'll find it in another.

Want to be far out? Help us build our NERVA nuclear reactor for space propulsion or design aircraft electrical power systems for tomorrow's super transports. Want to be way in? Help us unlock the ocean's secrets in our *Deepstar 4000* undersea exploration craft. If you're a skin diver, bring your equipment.

Or come help us revolutionize communications, radio and TV with more sophisticated microminiature electronic devices. Or would you rather help us rebuild urban areas?

If you care about quenching the world's thirst, you can help build water desalting plants throughout the

world. To date, we have installations for communities and industry from Key West to Kuwait. One of our desalting plants solved the Navy's fresh water problems when Castro cut the water line at Guantanamo.

If you're interested in computers, we're a leader in both their use and application. And not just computers that do a payroll; we're applying computers to steel mills, rapid transit systems, oceanographic research ships and automated warehouses.

Isn't this the wide freedom of choice you want at the start of your career? Talk to your Westinghouse recruiter about it when he visits your campus during the next few weeks or write: L. H. Noggle, Westinghouse Educational Center, Pittsburgh, Pennsylvania 15221.

*An equal opportunity employer*

You can be sure if it's Westinghouse



\*The Westinghouse Operating Groups: Consumer Products; Industrial; Construction; Electronic Components & Specialty Products; Atomic, Defense & Space; Electric Utility.

**Welcome  
to the cold,  
cruel world.**

Of course, if your father's a millionaire, or you're about to marry an heiress, then you have no problems. But, if not, then there's only one sensible thing to do. Come to work at Allison Division of General Motors.

There's nothing cold or cruel here. Just the opposite. Particularly if you're an engineer with big ideas. Aerospace projects? Allison's got them. Turbofan. Turbojet. Turboprop. Turboshaft. Military and commercial applications right across the board.

Maybe you're more down-to-earth. Fine. Some of Allison's advanced motor vehicle projects will be more your cup of tea. Like the new M551 General Sheridan, for instance. The powershift transmission, of course, is our specialty, and even the gun launcher is an Allison brainchild.

There's more. And you can be part of it. Take your time. Check them all. But don't forget Allison. Remember: life can be beautiful . . . even without an heiress.

For the complete story, send for Allison's new brochure: Destination Tomorrow. Write Ken Friedlein, Scientific Placement, Dept. 400, Allison Division of General Motors, Indianapolis, Indiana 46206.



March, 1967

**Allison**  
An equal opportunity employer M/F

# Come with us and do something meaningful.

Rack up paper clip after paper clip. As you enjoy the painful search for new ideas.

To what end? The satisfaction of getting involved in a company already deeply involved in the world and its people.

Our Farm Centers help boost productivity at home and feed the world abroad. Our petroleum products are prime movers on earth, in the stratosphere, in the ionosphere. Our Total Energy applications provide economical power, heat, and light to more and more people.

The world-wide demand for new products and applications is constantly accelerating. We're meeting it with new answers to old questions and unique solutions for unique problems.

We need your answers, your solutions. In Research and Development, or Manufacturing, or Marketing, or Administration.

And we'll give you the time, the stimulation, the opportunity you need.

And we don't skimp on paper clips.

**Do something meaningful now.  
Write Harry L. Sheehy, Recruiting  
Coordinator, American Oil Company,  
Dept. 19-C, 910 South Michigan  
Avenue, Chicago, Illinois 60680**



An equal opportunity employer.



# SPARTAN engineer

VOLUME 20

NUMBER 3

MARCH, 1967

STAFF

- GARY ROMANS . . . . . editor
- TOM SCHAFER . . . . . features editor
- JACK SIMMONS . . . . . business manager
- PATTI STEPHAYN . . . . . copy editor
- EDD SIERECKI . . . . . staff writer
- GREG WHITNEY . . . . . staff writer
- BILL WENK . . . . . staff writer
- MIKE FELLBERG . . . . . staff writer

ADVISORS

- J. RYDER
- C. MENSENDICK
- T. FARRELL
- G. VAN DUSEN



This month's cover is done by Tom Price and is his interpretation of Bob Kaatz' article, From The Other Edge.

ARTICLES

- MAYBE ARMADILLOS WILL FLY THIS YEAR  
David Eaton . . . . . 9
- FROM THE OTHER EDGE  
Bob Kaatz. . . . . 11
- WATER-COOLED ELECTRONIC FIGLIGGIE . . . . 18
- EN' INEERING WORD PLAY . . . . . 23
- POEMS . . . . . 30
- AN ENGINEER'S VOCABULARY . . . . . 36

DEPARTMENTS

- EDITORIAL . . . . . 5
- PLACEMENT BUREAU . . . . . 14
- INDUSTRIAL NEWS . . . . . 27
- BRAIN SPRAINERS . . . . . 31
- ENGINEERS . . . . . 35
- ADVERTISER'S INDEX . . . . . 38



Member, Engineering College  
Magazine Associated  
Chairman: Howard K. Schwebke  
University of Wisconsin, Madison, Wisconsin  
Publisher's Rep.: Littell-Murray-Barnhill, Inc.  
369 Lexington Ave., New York 17, N.Y.  
737 N. Michigan Ave., Chicago, Ill.

Published four times yearly by the students of the COLLEGE OF ENGINEERING, MICHIGAN STATE UNIVERSITY, East Lansing, Michigan 48823. The office is on the first floor of the Engineering Bldg., Phone 517 355-3520. Subscription rate by mail \$1.00 per year. Single copies 25¢.

# Ready for engineering growth?

Check the fields of interest to you,  
and AiResearch, Phoenix will do the rest.



Turboprop engines for business and military aircraft



Nuclear turbo-electric power systems for space



Valves and control systems for space vehicle boosters

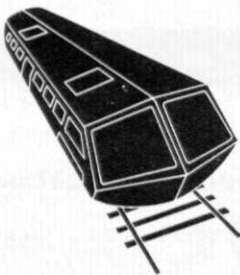

Gas turbine propulsion systems for high-speed rail cars



Onboard turbines and control systems for jetliners

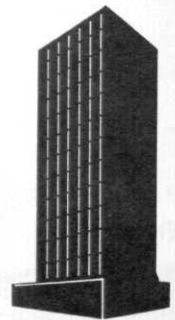

Gas turbine energy plants for on-site power

You can build a rewarding career in these and other exciting growth fields at AiResearch, Phoenix. Our training program lets you immediately apply your education in laboratory, preliminary design, and development projects. Then, you are assigned to an engineering team working on a project compatible with your interest and aptitudes.

At AiResearch, Phoenix, you can tackle problems in the design of high-temperature or cryogenic valves; work on secondary power systems for transonic, supersonic, or hypersonic aircraft; advance the state of the art in turbomachinery; or help develop sophisticated systems for missiles, boosters, or manned spacecraft.

Interested? Fill in the coupon. We'll send you all the facts about AiResearch, and let you know when our representative will visit your campus.

Mr. Larry Derksen



**AiResearch Manufacturing Company**  
Division of The Garrett Corporation  
402 S. 36th Street, Phoenix, Arizona 85034

Name \_\_\_\_\_

Home Address \_\_\_\_\_

City \_\_\_\_\_ State \_\_\_\_\_ Zip \_\_\_\_\_

College or university \_\_\_\_\_

Degree:  BS  MS  PhD Graduation date \_\_\_\_\_

I am interested in the field of:

- Turbomachinery
- Pneumatic, hydraulic, and mechanical control systems

I am interested in this type of work:

- Preliminary design
- Mechanical design
- Development
- Testing

# Assessment Of The Goals Of Engineering

*The editorial this month is being devoted to the following ten items which constitute a summary of a report by the Panel on Engineering Education on the goals of engineering. They are being printed in the hope that they will help the engineering student at M. S. U. analyze his college and the education which he is getting.*

- I. The growing demands upon the profession of engineering to assume leadership in the constructive integration of technological change and human fulfillment in a time of accelerating change requires a total of reassessment of engineering education.
- II. As an instrument of national purpose, engineering education should provide the formal basis for preparing the nation's engineering manpower with the capability, knowledge, understanding, and insight to fulfill the technological needs of society on a timely and effective basis. Such preparation should include the foundations for breadth of vision, leadership, and statesmanship with appropriate disciplinary balance and flexibility to meet new tasks and opportunities.
- III. There are a variety of useful patterns for institutional responsiveness to national engineering educational goals. Each institution should examine its resources and identify goals most suited to its own resources and capabilities.
- IV. To prepare engineering students for rapid technological change and for growing responsibilities in industry and government, the emphasis in instruction must be placed more upon the development of the potential capacities and insights in the individual and less upon the transfer of generally prescribed content in standardized courses.
- V. Since engineering students vary widely in preparation, capacity, interest, and potential contribution, it is contrary to sound educational policy to standardize curricula, degrees, methods, or periods of instruction across institutions at the expense of flexibility, experimentation, and wholesome diversity among and within institutions.
- VI. The educational process depends for its success upon close interaction between teacher and student. Steps should be taken to increase the opportunities for this interaction to occur to provide the essential guidance needed by the student in maturing as an individual, developing a sense of responsibility and a worthwhile set of values, and in becoming committed to ideals and a course of action.
- VII. Accreditation of schools of engineering in the future must be reexamined in light of the need for flexibility and diversity among institutions and programs. Standardization beyond a marginal limit of acceptability will retard rather than enhance the quality and effectiveness of engineering education.
- VIII. To the extent that the licensing principle represents a restrictive influence on flexibility and innovation in engineering education, the principle itself and the laws on which it is based should be reviewed and modifications considered by the professional and technical societies concerned.
- IX. Engineering societies should review their role in the total spectrum of engineering education, research, and practice and should develop objectives and programs responsive to advances in technology and the needs of the profession and society.
- X. Learning is a lifetime process, continuing through all of the formal phases and extending throughout the years of professional practice. It includes the sum of all experience outside the classroom and instruction within. The goals of education should give recognition to this principle and emphasize the need to optimize a lifetime of learning. Such optimization should consider both the effectiveness of the pre-college preparation and the means and methods of extending the postcollege educational process over the life span of the engineer.



# Twenty-five hundred dollars in cash awards to engineering and metallurgy students.

The Forging Industry Educational and Research Foundation announces a \$2,500 award competition for the best paper on the subject "How Mechanical and Physical Properties of Impression Die Forgings Are Best Utilized in Designing Forgings for New Applications." First prize, \$1,000, plus eight other awards totaling \$1,500.

Competition is open to senior and graduate engineering and metallurgy students. Length of the paper, 3,000 to 3,500 words. Deadline for completed paper: May 10, 1967.

Winner and his faculty advisor will also receive an all-expense-paid trip to White Sulphur Springs, West Virginia, where the award presentation will be made at the 1967 meeting of the Foundation.

For full details fill in and mail the coupon or write:

*The President*

## Forging Industry Educational and Research Foundation

55 Public Square • Cleveland, Ohio 44113

Name \_\_\_\_\_

Address \_\_\_\_\_

School \_\_\_\_\_

Faculty Advisor \_\_\_\_\_



New hardbound 520-page *FORGING INDUSTRY HANDBOOK*, describing forging design, applications and technology, is available to students at special low price of \$2.50. Write, enclosing check or money order, to Forging Industry Association, 55 Public Square, Cleveland, Ohio 44113.



16-millimeter sound and color film, *TO BE FORGED*, describes forging process and design considerations. Length 18 minutes. Sponsored by Forging Industry Association, available on loan free from regional film libraries of Modern Talking Picture Service, Inc., 1212 Avenue of the Americas, New York, N.Y. 10036.



# Opportunities at Anaconda

in mining and metallurgy here and abroad, at Anaconda American Brass Co., Anaconda Wire & Cable Co., and Anaconda Aluminum Co.

Talents and skills like yours will always be needed by Anaconda. But that's only half the story. The other half is what Anaconda has to offer you: important positions in exploration, mining, extractive metallurgy, manufacturing, scientific research, sales and administration. For example, take a look at only eight of the hundreds of recent graduates who found what they were looking for at Anaconda: and vice versa.



**Top:** LUIS LOZANO (BS Met. E., Brooklyn Poly. '61) is research metallurgist at Anaconda American Brass Company's research and technical center.

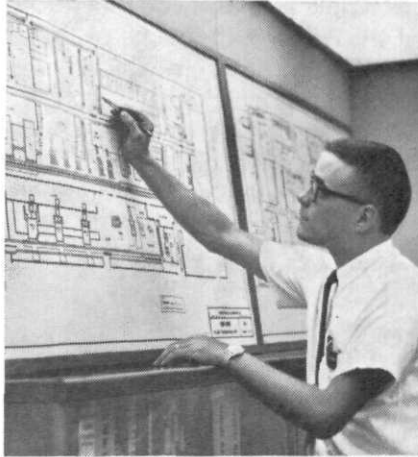

**Top:** GEOFFREY IRELAND (BSME, U. of Louisville '63) is assistant plant engineer at Louisville works of Anaconda Aluminum Company.

**Below:** ROBERT SWIRBUL (BS Bus. Ad., U. of Tampa '58), center, district manager of Dallas sales office of Anaconda Wire and Cable Company, reviews cable specifications with power utility personnel.



**Left:** PETRUS DUTOIT (BS Mining Engrg., Montana Tech., '56), mining engineer, at the controls of a raise boring machine in the Mountain Con mine. This mine has the latest in underground mining equipment.

**Below:** LAWRENCE KENAUSIS (BS Chem., Holy Cross '53; MS Chem., Boston College '55; PhD Chem., U. of Penn. '61) is senior research metallurgist at Anaconda research and technical center in Waterbury, Connecticut.



**Top:** JUDITH HIHNALA (BS Bact., Montana State '63) studies bacterial leaching of copper and zinc ore and concentrates in extractive metallurgical research laboratory.



**Top:** GLENN ZINN (BS Geol. E., Mich Tech. '66), geophysicist with the geophysical department's southwest office in Tucson, Arizona, is studying toward a master's degree in geophysics at University of Arizona.

**Below:** FRANKLIN ANDREWS (BS Math., Northern Ill U. '62), manager—quality assurance at Sycamore plant of Anaconda Wire and Cable Company, checks environmental stress crack test of polyethylene.

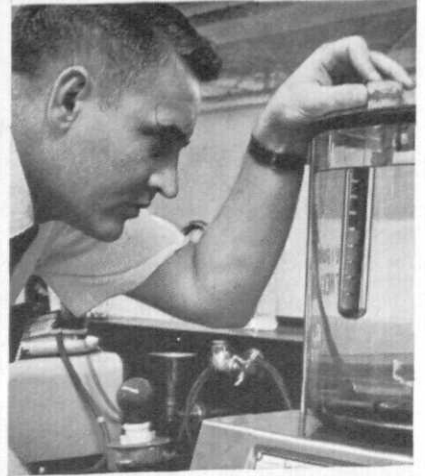

If you would like more information about the opportunities at Anaconda, or would like to apply for employment, write to: Director of Personnel, The Anaconda Company, 25 Broadway, New York, N.Y. 10004.

An equal opportunity employer.

67121



# Get off the ground with International Harvester...

**of all people** All military transport helicopters in Viet Nam are equipped with International Solar Titan® gas turbines—auxiliary power for takeoff, landing and hydraulic operations. Gas turbines are one more part of our growing world of power at IH. While our farm equipment business is booming, there are many different kinds of opportunities for you at IH. With us, the name of the game is POWER. We apply mechanical power to do an endless number of jobs. We're a leader in construction equipment, a marine engine builder, steelmaker, and the world's leading producer of heavy duty trucks.

IH offers more areas for you to grow in than you can imagine. We need agricultural engineers, mechanical, industrial, metallurgical, general, civil and electrical engineers with many diverse talents and interests. We offer you an ideal combination of opportunity, responsibility and individual treatment. How fast and high you climb at International Harvester will be pretty much up to you.

PHOTO COURTESY OF THE BOEING COMPANY'S VERTOL DIVISION



**International Harvester puts power in your hands**

Interested? Contact your Placement Officer to see an IH representative when he visits your campus. Or write directly to the Supervisor of College Relations, International Harvester, 401 North Michigan Avenue, Chicago, Illinois 60611.

AN EQUAL OPPORTUNITY EMPLOYER



# MAYBE ARMADILLOS WILL FLY THIS YEAR

## *Tau Beta Pi Pledge Essay*

by David J. Eaton

Two students, John and George, are involved in a discussion. Both are intellectually inclined and well informed, having read many volumes of philosophy, art, science, and history. But what are they saying? John says, "I can't be serious when I think of those people who trust in a God that personally supervises every atom in the universe." George chuckles in agreement. There is no argument, since both are assuming that they can base the powers of God on those of man. This is assuming too much. Certainly there are many things a man cannot do, but this does not, of course, imply that a being of higher ability could not as well. A man says he is sure that flying saucers are not interplanetary vehicles. Another says he is sure that they are. What foolishness! We have no way of determining a conclusion, so how can we form one?

The mark of an intellectual is not how well he knows the philosophy of St. Augustine, or how

many symphonies he can recognize, but how well he can think on his own. Thinking on his own, he should not read accounts of prophecies or ghosts and say "ridiculous." Rather he should say "interesting" or "maybe this is true". From there, he could investigate what might be the case if an account is true, or what effects the ideas have on his own thinking.

This problem of "assuming too much" has more practical aspects. It is sadly common. How often we check in only one direction when crossing a one-way street, ignoring the other possibilities. We drive cars without observing cross roads, because we have the "right of way". The highway accident rate would probably be much lower if every driver exchanged thoughts of "he won't cut in front of me" for "he could cut in front of me, so I will be ready."

Tomatoes never fall up, we argue, but how can we neglect the possibility that, say, every

forty thousand years, tomatoes do fall up? Perhaps tomatoes will start falling up this year. Perhaps squirrels will start chasing dogs next week. Perhaps all the steel in the world will dissolve tomorrow. Impossible? Probably, but the possibility is there. The important point is that we cannot say, "This can never be."

We regard a frog as having little conception of a man and no conception of the working of a screwdriver, a simple tool to a man. But consider this: frog is to man as man is to X. What concept does man have of X? Consider this: worm is to man as man is to Y. What concept does man have of Y? Consider this: mushroom is to man as man is to Z. What concept does man have of Z? The incredibility, the "impossibility" of X is great, of Y greater, of Z still greater. Is it not possible that there are many things man cannot begin to comprehend? There is no reason that he cannot or should not allow for this possibility.

# JOIN THE IDEA CORP.

Right now, hundreds of engineers, chemists, and physicists are exploring their own ideas at NCR. We encourage them because we consider idea-people as the backbone of technological advancement in our field of total business system development.

And it works. Business Management magazine, in its list of "emerging ideas of 1966," credits NCR with two out of seven: pioneering in laser technology for recording data, and development of our new PCMI microfilm storage system.

Whether you're a seasoned pro, or an ambitious self-starter, and whatever your degree, if the excitement and satisfaction of start-to-finish idea development appeal to you, you'll go far with NCR. And so will your ideas.

Here's a good idea to start with: write to T. F. Wade, Executive and Professional Placement, NCR, Dayton, Ohio 45409. An Equal Opportunity Employer.

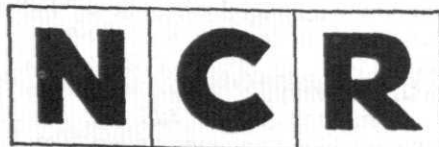

THE NATIONAL CASH REGISTER CO. ®

When I was in high school, my math teacher said, "You should go into engineering. It's the field to go into these days, you know." Somewhat intrigued by his challenge and soberly realizing that I would soon have to make a decision as to whether I would go to college, get a job at home, or fulfill my military obligation, I initially decided that perhaps he was right. Engineering, why not? A fast growing field, financial gains galore, a respectable position, opportunity to use my talents, these were the ideas which raced through my mind.

When the time came to decide, I enrolled at a large, prominent engineering college, and the grind began. It was soon apparent that I was lacking in conviction and maturity, the result being that my major was largely social rather than technical. The second and more consequential result was that I was asked to withdraw from school because of poor academics.

Seeking to soothe my wounds, I joined the service where I could both hide and start afresh. Once again I entered the field of electronics, and was given extensive training. This early taste of success convinced me that all the "boozing around" I had done in college had cost me quite a lot. Later, I was given the opportunity to attend Officers' Training School, and the road seemed clear, except for that bad college record. I conveniently "forgot" to report that record. On the last day of school I was rudely shocked with the discovery that they had found me out. I was expelled immediately and reassigned to my previous duties in electronics.

I thought the world had come to an end for me, and in some respects, perhaps it had. I had had my fill of all the short cuts and activities which had kept me from reaching my goals. It was at this particular time that I was confronted with the fact that God had not been included in any of my well laid plans, and in my hurry to succeed, I had not considered the aspect of eternity. At first, the idea of God's having any claim on me seemed impertinent, for what had God ever done for me that I should owe Him anything? Gradually I had to admit that it was not God who owed me

anything, but I who owed Him everything. He had already given His Supreme Gift. It was now mine to respond.

In the months that followed, my commitment brought on a new conflict. It seemed to me that the concepts of service to God and a career in electronics were mutually exclusive. Finally I realized that I was not supposed to change personalities or magically acquire new talents, but that God expected me to use what He had by nature given me. Only then did I begin to find real fulfillment in my electronics work.

After being discharged from the service, I tried to enroll in college once again, this time with the conviction that my training was going to be used, not for me, but for my Lord. However, admission came only after great perseverance on my part, because of my previous college record.

Now that I'm back in school again, I find that my whole perspective has changed. One problem which has been solved is that of a goal. Previously, my decision to study engineering had been based mainly on the opinions of others, and on the pressures which society has brought to bear concerning a young man's future. All this was quite unreal, because I had not really looked at myself as an individual. Having come into a vital relationship with the Creator, Who made me and alone really knows me, I have confidence in His ability to lead me into the greatest possible fulfillment of myself. With this as my goal, I can yield my aptitudes and abilities to be used in any way whatever by God and have absolute peace about it.

Often the thought comes to mind of money and security. Who doesn't think of these things? It is one thing to think about them and quite another to be dominated by them. In my recent past, for the most part, I had thought only of the monetary aspects of my future career. Engineering, being a very lucrative field, was always high on my list of possible professions. The stress laid upon finances today is amazing, and it would appear at first that if one has money, all will be well. I find that money and the security de-

rived from it are not primary considerations at all, these things being transcended by the assurance that my labors are being and will be reimbursed in a most abundant fashion. This is a very comforting factor when I consider that this provision is promised even beyond the boundaries of time.

The closely related concept of success comes up quite frequently. Some maintain that it takes ambition, others say education, the right breaks, and so on. These are certainly all involved as ingredients, but the

# FROM THE OTHER EDGE

by Bob Kaatz

actual attainment of success is such a relative matter. It depends on where you are, who evaluates you, what you are doing, and some other things I haven't thought of. Success is a very elusive thing, such that one may never know whether he has succeeded or not and so some tensions arise. These tensions go away if I realize that as I am obedient to God, I've already succeeded. Abraham Lincoln once said, "I am not bound to succeed but I am bound to live up to what light I have." This seems to be the heart of the matter -- obedience to God.

It is a continual joy for me as I study in engineering to be able to see more and more how marvelous this world is. Things like the order that exists in the universe, the power involved in many of the processes that go on around us, or the intricate nature of these processes are brought up. Even though it is possible to regard these things by themselves apart from God, they seem incomplete or somewhat discontinuous to me unless

CONTINUED ON PAGE 36

## what's so special about Collins?

Unusual career opportunities? Fringe benefits? Ideal locations? Exciting work? Advancement potential?

Well, almost every industrial concern can offer those.

We can show you dozens of photographs of career people working at Collins, using the finest facilities and tools available. But that isn't the whole Collins story.

You see, one of our biggest specialities is you. Your speciality is special at Collins. Every major engineering breakthrough at Collins can be traced to an individual specialist or team of specialists.

Which leads to another speciality: state-of-the-art communication systems. Collins' record of "firsts" over the years is an enviable one: single sideband development, space communication systems, aircraft all-weather landing systems, high-speed data communication and message switching networks—to name a few.

We suggest you contact Collins' representative when he's on campus. And contact your college placement officer for details.

The rest of the Collins story? We frankly can't tell you at this moment.

You'll be writing it.

COMMUNICATION / COMPUTATION / CONTROL



COLLINS RADIO COMPANY / DALLAS, TEXAS • CEDAR RAPIDS, IOWA • NEWPORT BEACH, CALIFORNIA • TORONTO, ONTARIO  
Bangkok • Beirut • Frankfurt • Hong Kong • Kuala Lumpur • Los Angeles • London • Melbourne • Mexico City • New York • Paris • Rome • Washington • Wellington



## We made a raincoat for a bee.

Not just an ordinary raincoat either. It's a skintight plastic coat so thin you would never know it's there. Yet it covers the bee completely, right down to the individual hairs on the bee's knees. It was done to protect specimens in a natural history museum.

But we didn't spend 12 years on a new plastic just to protect bees. We developed parylene to protect things like bees—fragile, complex things so intricate in shape they are next to impossible to coat.

For instance. Each tiny grain of a highly reactive chemical can be protected to provide stability in the presence of gases or moisture. Tiny electronic capacitors, just one-fifth

the size of previous types, can be insulated with a coating as thin as eighty-millionths of an inch. Union Carbide finished the initial development work on parylene in February 1965. Until then, there was no comparable way to encapsulate delicate objects.

Parylene is one of the latest, most sophisticated new plastics to result from the exploring, researching and discovering that is always going on at Union Carbide. The same scientific inventiveness that has put Union Carbide into a greater variety of plastic products than anyone else. Ever.

That's why we're always looking for talented young people to help us. An equal opportunity employer.



THE DISCOVERY COMPANY

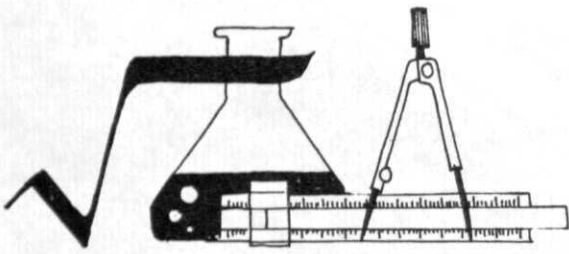

# PLACEMENT BUREAU

The following is a tentative listing of companies interviewing Engineering majors during the months of April and May, 1967. Each Monday of the regular term the Placement Bureau publishes a bulleting containing the companies interviewing and majors and degree levels sought for the following week. This bulletin is the most reliable source of Placement Bureau information. Appointments should be arranged at least two days prior to the time of interview.

Week of April 3-7

IBM  
General Motors  
Vitro Labs  
Naval Civil Engineering Lab  
Sarkes Tarzian, Inc.  
Miles Lab  
General Telephone & Electronics  
McGill Manufacturing, Inc.  
Hawaii Telephone Company

Week of April 10-14

General Electric  
IBM  
Twin Disc Clutch Co.  
National Water Quality Lab  
Tee Pak, Inc.  
A.T. & T. Long Lines  
Lyband Ross

Week of April 17-21

General Magnetic Corp.  
Vestal Chemical Lab  
Fisher Body -- Div. of G.M.  
Corning Glass Works  
Abex Corp.  
General Motors Technical Center  
Continental Motors Corp.  
Mechanical Handling Systems  
Electro -- Voice  
RCA  
General Cable Co.  
Roche Laboratories  
Automatic Signal  
McDowell Wellman Engineering Corp.

Aluminum Extrusion Inc.  
Polymer International Corp.  
Oriko Pharmaceutical Corp.  
Associated Spring Corp.  
Burroughs Wellcome & Co.

Week of April 24-28

Federal Power Commission  
Guardsmark, Inc.  
Avis Industrial Corp.

Week of May 1-5

Factory Mutual Engineering Div.  
Keeler Brass Co.

Week of May 8-12

Burroughs Wellcome & Co.

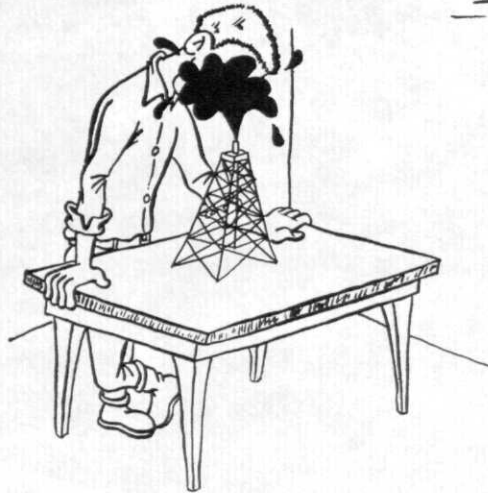

## ARCH.



## PETROL.



## MIN. & MET.



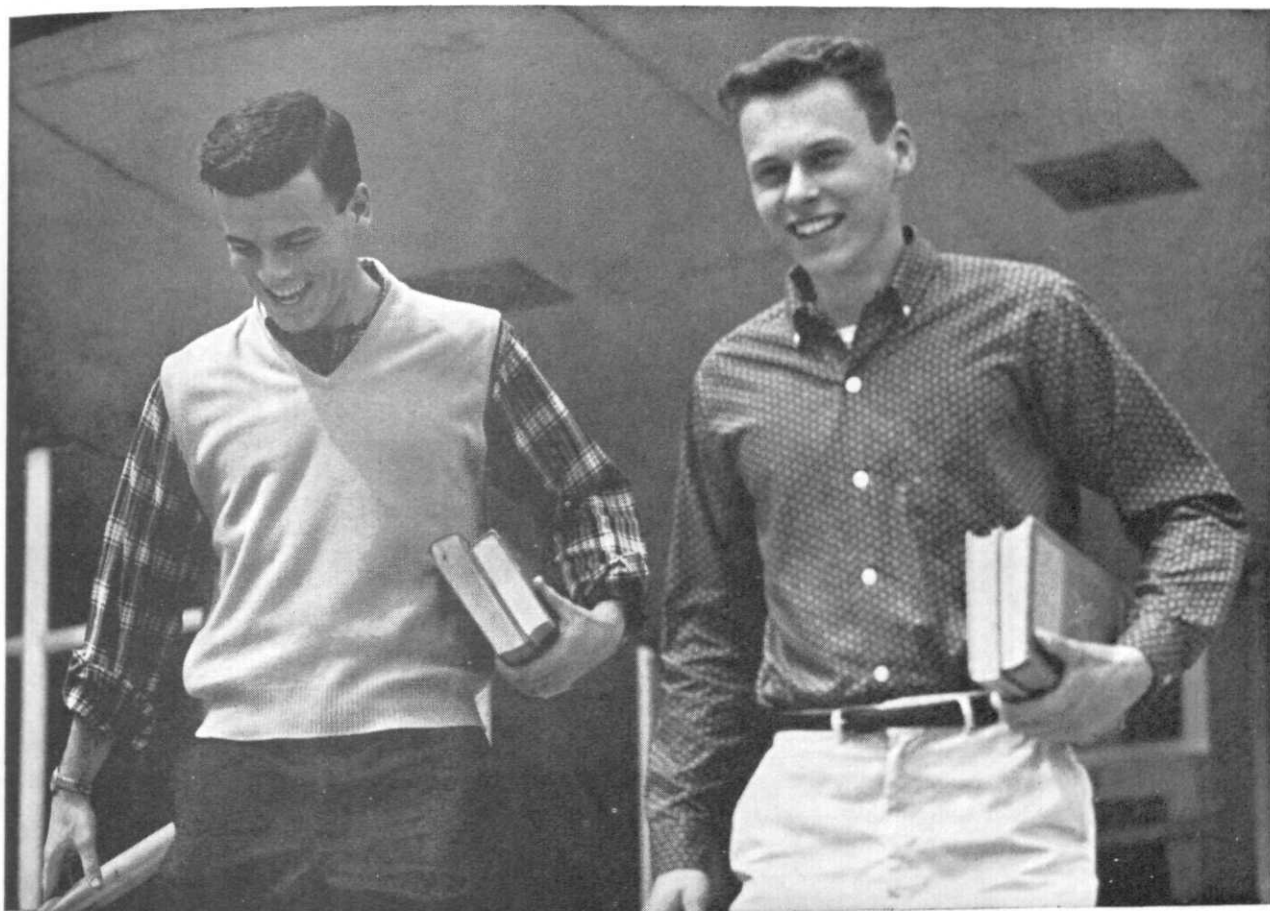

## What turns you on?

Responsibility? Professional Recognition? Financial Reward? We know of no company better able, or more disposed, to satisfy these goals than Celanese Corporation. Why Celanese? You'll be working for a young company that's growing fast—and "plans" to keep growing. 1965 sales rose 23% to over \$860 million. Our future planned growth depends on our ability to attract top-notch people who can grow with us. Sound good? If you feel you can perform in our fast-moving, intellectually demanding environment, it should.

If you're ambitious, flexible and imaginative, well trained in chemistry, physics, chemical, electrical or mechanical engineering, marketing, finance, accounting or industrial relations, we'd like to talk to you—regardless of your military commitments. And you'll like what you see at Celanese. Discuss us with your faculty and Placement Officer and see our representative when he is on your campus. Or write to: John B. Kuhn, Manager of University Recruitment, Celanese Corporation, 522 Fifth Ave., New York, N. Y. 10036.



**CELANESE**

AN EQUAL OPPORTUNITY EMPLOYER



# Put yourself in our place.

Step right into the picture on a marine propulsion problem. Or into our nuclear fuel laboratory. Or the design of one of the biggest boilers ever built in America.

Tomorrow, who knows? You could be on the B&W team that launches an entirely new product.

We're big enough (\$480 million last year) to take on some pretty exciting projects. But small enough to give you a challenging job, not just desk space.

Come grow with us at Babcock & Wilcox.

We started in boilers and steam generation, then moved on to atomic power stations, nuclear marine propulsion, refractories, specialty steel, computers and control systems, closed circuit TV and specialty machine tools. (We still make the best boiler in America.)

Want to talk about the future? Your future? See your placement officer. Or write to Manager, College Recruiting, The Babcock & Wilcox Company, 161 East 42nd St., New York, N.Y. 10017. A good place to work and grow.



**Babcock & Wilcox**

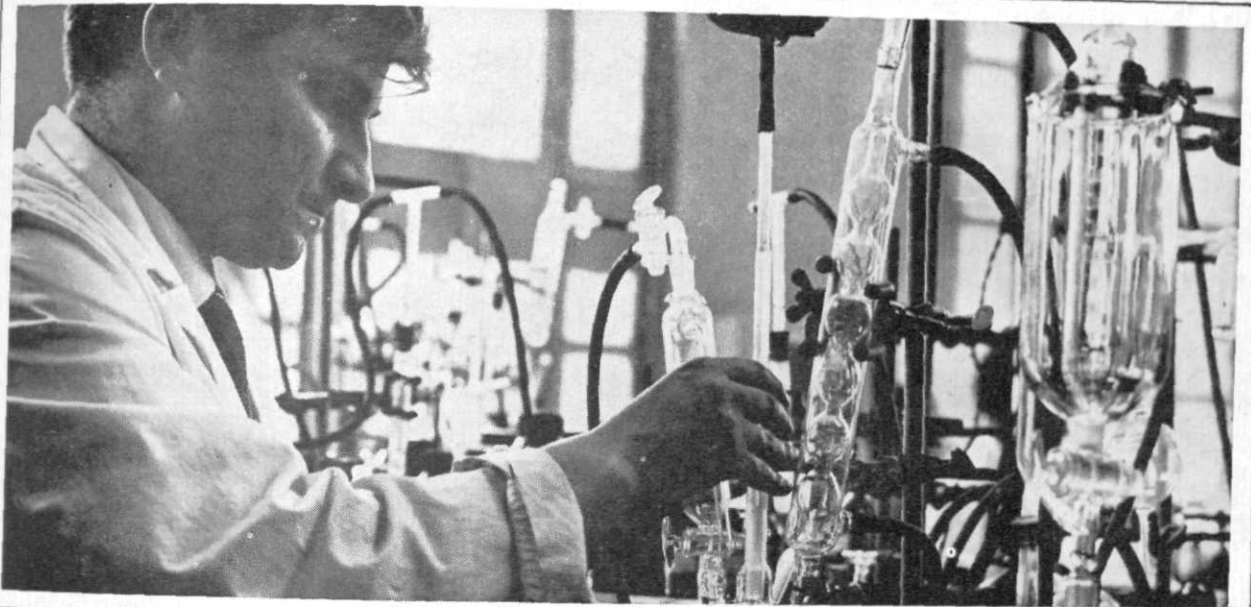

Photo: Montecatini Co.

ENGINEERS/SCIENTISTS

**H**ow many new  
microcircuit packaging ideas  
...new system configurations  
...and punctured  
trial balloons will we need,  
to spare this Milan scientist  
an experiment  
he doesn't need.

In the last year alone, hundreds of new synthetic materials and metal alloys, both ferrous and non-ferrous, have been developed. In this avalanche of new materials, how can a scientist best search the literature to do original work without duplicating someone else's effort and wasting his own valuable time? One answer may be Graphic Communications that can give him all the known facts on a specific subject from a central memory bank.

Presenting knowledge in many forms quickly and cheaply to millions who are remote from it today is a Xerox goal. Our aim is to get information from man to machine and back to man within seconds. We're close to it. We're already working on exciting new concepts of communications such as 3-dimensional imaging, color xerography and global transmission of images through computer systems. All designed to condense the information explosion and transmit its ideas at speed approximating real-time. This is our aim.

Why not pursue it with us.

Your degree in Engineering, Science, Statistics or Mathematics can qualify you for openings at Xerox in fundamental and applied research, engineering, manufacturing, programming and marketing/sales.

To learn more, see your Placement Director or write to Mr. Stephen G. Crawford, Xerox Corporation, P.O. Box 1540, Rochester, New York 14603.

**XEROX**

An Equal Opportunity Employer (M/F)

# WATER COOLED ELECTRONIC FIGLIGGIE

ICUR12.

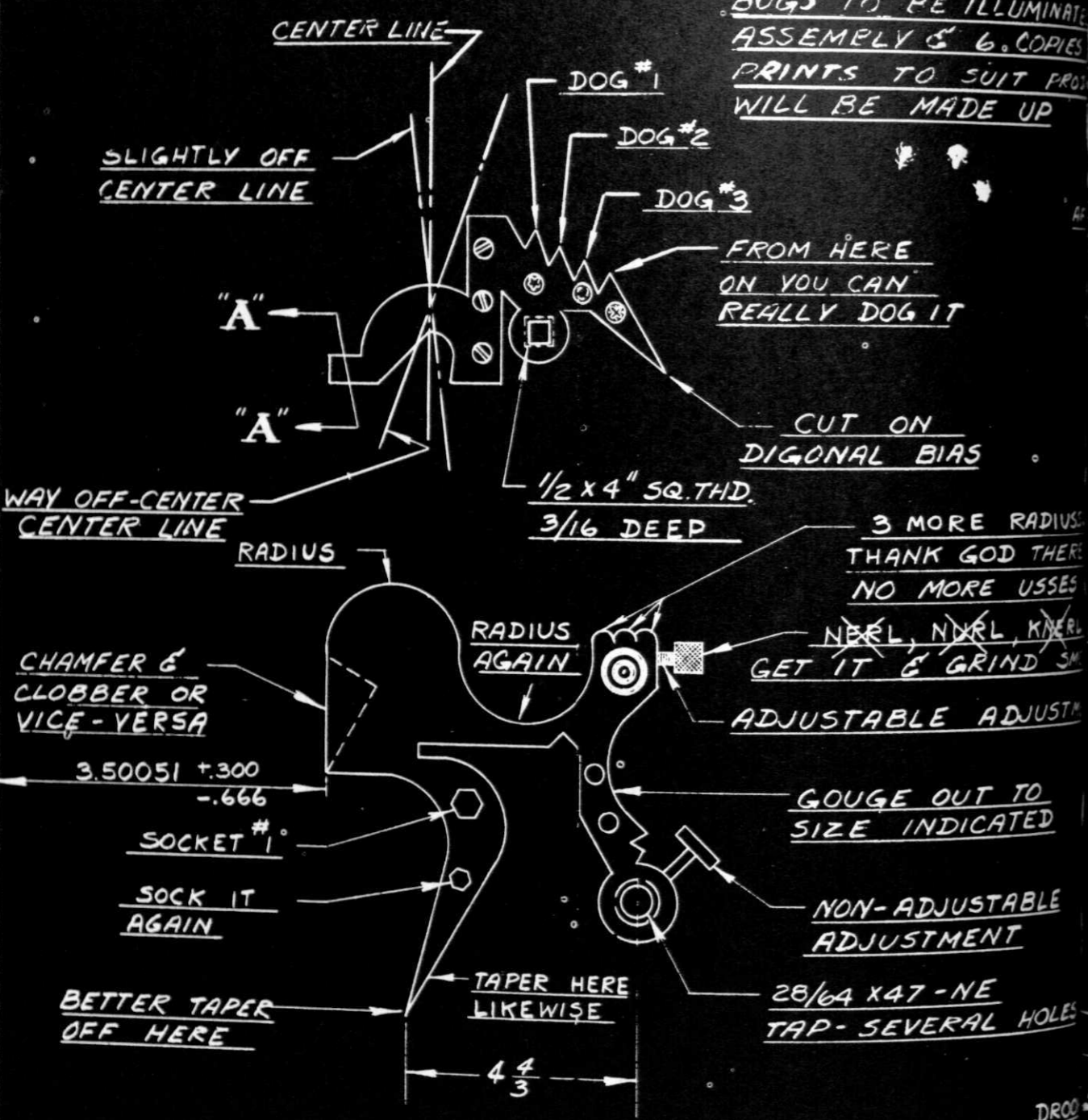

NOTE:  
BUGS TO BE ILLUMINATED  
ASSEMBLY & 6 COPIES  
PRINTS TO SUIT PROSM  
WILL BE MADE UP

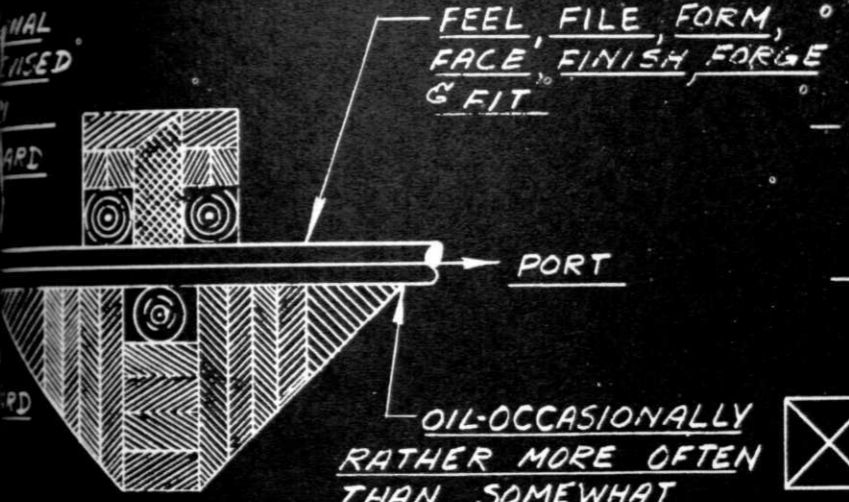

GOVERNMENT REJECTED  
FOR YOUR PROTECTION

- BREAK ALL CORNERS  
SHARP UNLESS  
OTHERWISE SPECIFIED  
- ANY SIMILARTY BETWEEN  
THIS MACHINE & AN IDENTICAL  
MACHINE IS PURELY INCONSEQUENTIAL



COPIES SENT TO  
DAMN NEAR  
EVERBODY  
DATE:



CAUTION!!  
KEEP UPPER BOTTOM RIGHT HAND CORNER OVER ABOUT 1/16 LOWER THAN LEFT-HAND CENTER CORNER WHICH SHOULD BE DOWN A LITTLE HIGHER THAN MIDWAY APPROXIMATELY  
NOTE!!  
AN 8X10 FT. 3 COLOR REPRODUCTION OF THIS DRAWING SUITABLE FOR FRAMING CAN BE OBTAINED BY SENDING 25¢ IN COIN & THE HEADS FROM 3 JUNIOR DESIGN ENGINEERS TO THE AMALAGAMATED WIDGET WORKS, WEST LOCKWASHER PA.

SCALE	MATERIAL	NAME OF PART	PART NO
1/16 CLEAR	DR. T. SQUARE 1-11	AMALGAMATED WIDGET WORKS	
FAST	CK I.M. COMPAUSED	WEST LOCKWASHER PA	
UNLIMITED	WELD ONDR	WATER COOLED ELECTRONIC FIGLIGGIE	
PAR 6		DATE OF RE. PART NO	ICUR12
	FIRST USED ON		
	REV NO	REVISION	DATE BY CK APD
	REV NO	REVISION	DATE BY CK APD

**NEWS**

**for**

1966  
1967

**ENGINEERING**

**GRADUATES**



# Continued expansion of our military and commercial business provides openings for virtually every technical talent.

As you contemplate one of the most important decisions of your life, we suggest you consider career opportunities at Pratt & Whitney Aircraft. Like most everyone else, we offer all of the usual "fringe" benefits, including our Corporation-financed Graduate Education Program. But, far more important to you and your future, is the wide-open opportunity for professional growth with a company that enjoys an enviable record of stability in the dynamic atmosphere of aerospace technology.

And make no mistake about it . . . you'll get a solid feeling of satisfaction from your contribution to our nation's economic growth and to its national defense as well.

Your degree can be a B.S., M.S. or Ph.D. in: **MECHANICAL, AERONAUTICAL, CHEMICAL, CIVIL (structures oriented), ELECTRICAL, MARINE, and METALLURGICAL ENGINEERING • ENGINEERING MECHANICS, APPLIED MATHEMATICS, CERAMICS, PHYSICS and ENGINEERING PHYSICS.**

For further information concerning a career with Pratt & Whitney Aircraft, consult your college placement officer—or write Mr. William L. Stoner, Engineering Department, Pratt & Whitney Aircraft, East Hartford, Connecticut 06108.

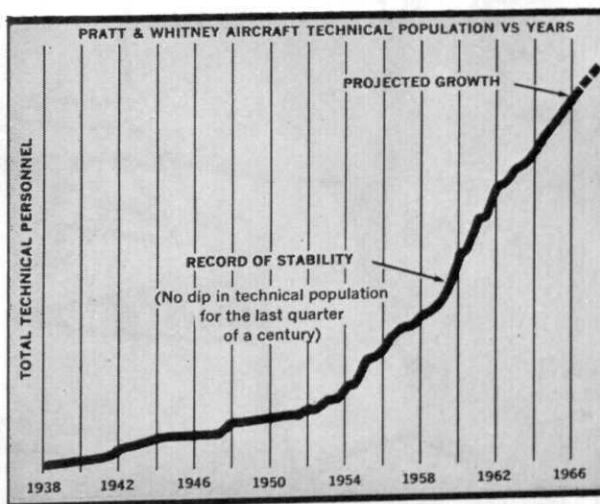

Take a look at the above chart; then a good long look at Pratt & Whitney Aircraft—where technical careers offer exciting growth, continuing challenge, and lasting stability—where engineers and scientists are recognized as the major reason for the Company's continued success.

**SPECIALISTS IN POWER . . . POWER FOR PROPULSION—POWER FOR AUXILIARY SYSTEMS. CURRENT UTILIZATIONS INCLUDE MILITARY AND COMMERCIAL AIRCRAFT, MISSILES, SPACE VEHICLES, MARINE AND INDUSTRIAL APPLICATIONS.**



**Pratt & Whitney Aircraft**

CONNECTICUT OPERATIONS EAST HARTFORD, CONNECTICUT

DIVISION OF UNITED AIRCRAFT CORP.



An Equal Opportunity Employer



**Last year, thousands of lawyers, bankers, accountants, engineers, doctors and businessmen went back to college.**

**And not just for the football games.**

We'd like to clear up what appears to be a misunderstanding. It is somewhat popular on campus to decry a business career on the grounds that you stop learning once you start working for Cliché Nuts & Bolts.

That idea is groundless.

We can't speak for Cliché, but we can for ourselves — Western Electric, the manufacturing and supply unit of the Bell System. 6 out of 10 college graduates who have joined us over the past 10 years, for example, have continued their higher education.

How're these for openers:

W.E.'s Tuition Refund Plan lets employees pursue degrees while

working for us. Over 6 thousand have attended schools in 41 states under this plan. We refund more than \$1 million in tuition costs to employees a year.

To name another program: advanced engineering study, under the direction of Lehigh University, is conducted at our Engineering Research Center in Princeton, N. J. Selected employees are sent there from all over the country for two year's concentrated study leading to a master's degree.

You get the idea. We're for more learning in our business. After all,

Western Electric doesn't make buggy whips. We make advanced communications equipment. And the Bell telephone network will need even more sophisticated devices by the time your fifth reunion rolls around. The state of the art, never static, is where the action is.

At Western Electric, what's happening is the excitement and satisfaction of continued doing and learning. If this happens to appeal to you, no matter what degree you're aiming for, check us out. And grab a piece of the action.



**Western Electric**  
MANUFACTURING & SUPPLY UNIT OF THE BELL SYSTEM

# ENGINEERING

word play

**M**ASS

HEAT

CONDUCTOR

MECHANICS

SCREWS

ELECTRON

WAVES

RESISTOR



CONDUCTOR

RESISTOR



Sundstrand systems serve a world in motion

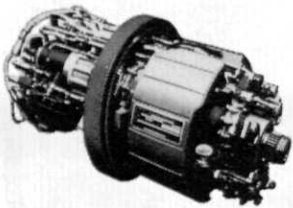
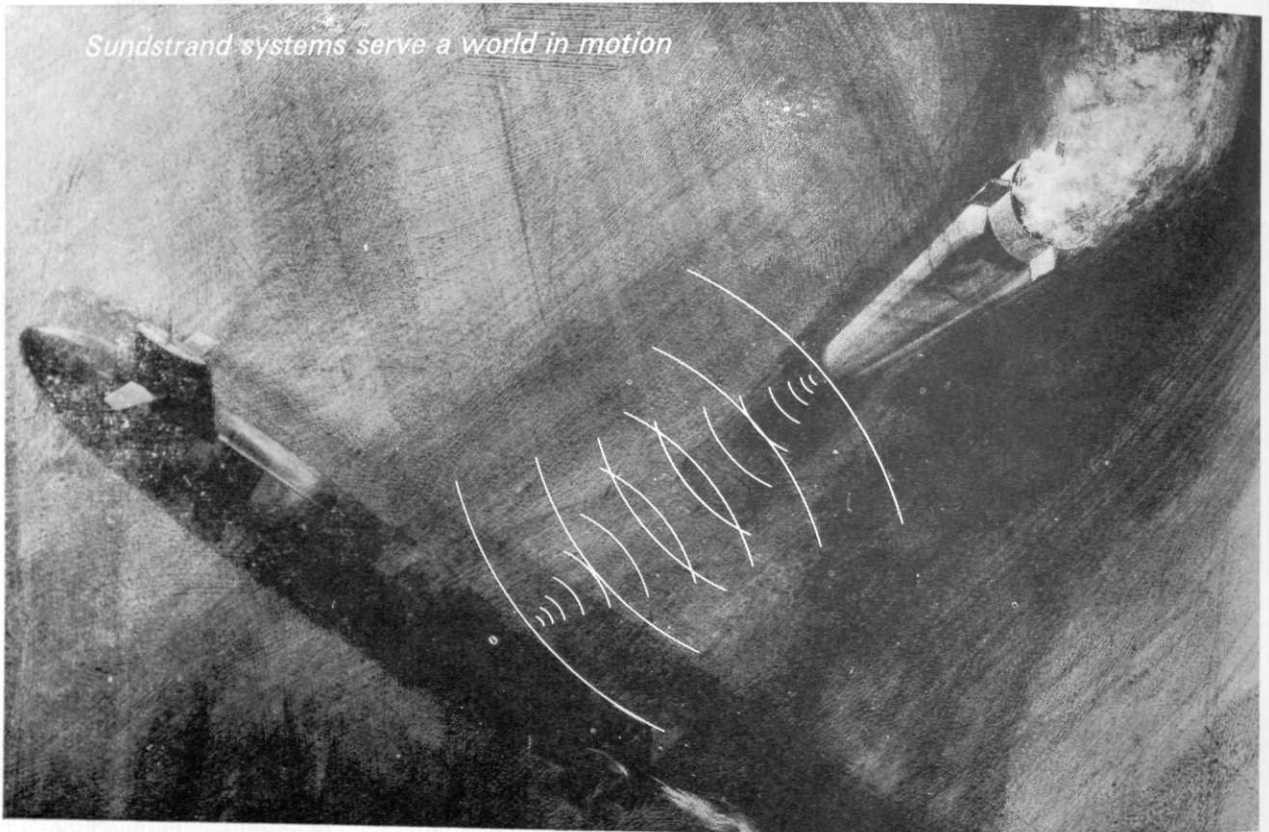

The challenge of torpedo propulsion at Sundstrand includes design, development, qualification, and initial production of sophisticated propulsion systems for advanced design torpedoes. These programs involve high-speed turbo-machinery for both open and closed-cycle systems, and experimental work with the latest high-performance fuels suitable for torpedo propulsion.

Sundstrand offers excellent career opportunities. Sundstrand engineers work on a variety of projects under excellent working conditions, enjoy definite project responsibility and follow-through. Consistent emphasis on engineering results in a sizable investment in research and development. Our new special test facility in Rockford, Ill., provides unmatched capability for R&D and production testing of Otto-fueled, open-cycle torpedo propulsion systems; closed-cycle organic Rankine-cycle power systems; miniature missile power units burning hydrazine propellants.

Consider a career at Sundstrand. We employ nearly 6000 people, enjoy approximately \$100 million annual sales—a steadily growing, medium-sized company, *on the move!* Torpedo propulsion, thermodynamics, supersonic transport, solid-state electronics, isotope power for space vehicles, hydrostatic transmissions for vehicle propulsion—these are the tomorrow-oriented fields we investigate. Join us!



## Home in on torpedo propulsion at Sundstrand

Now that you know something about us, how about letting us know something about you?

Talk with the Sundstrand Employment Manager when he visits your campus on March 9

Or, send your resume in confidence to  
**SUNDSTRAND PERSONNEL CENTER**  
1401 23rd Avenue, Rockford, Ill. 61101  
*An equal opportunity employer*

### Positions now open in the following areas:

- Turbo-machinery and thermodynamics
- Combustion engineering
- Gear design and manufacture
- Aircraft hydraulic pump and motor development
- Acoustics engineering
- Bearing design
- Circuit design and electronic packaging
- Application engineering
- Vehicle transmission design
- Electrical test equipment
- Manufacturing engineering

the day you start here  
is the day  
we start helping you  
outgrow  
your  
job

The way we look at it (not only here at Electric Boat Division, but in General Dynamics as a whole) good employes—properly placed, trained and motivated—are our fastest growing asset. So, right from the start, we'll be doing everything in our power to help you develop your full potential through a strongly-implemented management-sponsored program that makes your professional development a matter of planning, not chance.

This program, called "people development", is designed to spot your special capabilities—to help you move, to progress, even to change your product area or technical discipline if that's what it takes to increase the certainty of your success. Part of the program is a philosophy that charges each supervisor, whatever his level, with developing his own replacement. And our supervisors are adept at recognizing individual achievement and calling appropriate attention to it. Part of it, too, is one of the most extensive and far-sighted educational, study and post graduate pro-

grams ever offered by any company, to encourage continued academic proficiency. Hundreds of people in our Division participate each year.

But the thing that gives this approach of ours real point is the challenge and excitement of the field you'll be working in—Oceanology—a field as new as the Aerospace industry was new a dozen years ago, and as promising; a field that encompasses every means of undersea operation and exploration known to man.

And here, whether you're working on a deep diving research vehicle or an atomic sub, the opportunities for innovation (as well as growth for the innovative) are endless. For instance, every atomic submarine we build is treated as a new and different problem. Even ships in the same class differ since each succeeding one is, in fact, the state-of-the-art at the time we're building it. Within any sub, advances might

occur in nuclear shielding design; in heat transfer efficiency; in sound and vibration control; in new materials; in chemically based life support systems; or in a dozen other areas. And because of the close collaboration among men of many different technical disciplines, your thinking might spark a new idea in any one of them. Just as their thinking might spark yours.

Living and working in Groton, Connecticut is a rewarding experience in itself. For in this unique nautical community you are not only close to the men and women who build and sail submarines, but to all the abundant pleasures of the sea. (Not that you're far from more metropolitan pleasures if that's your preference.)

---

So, if you've missed our on-campus interviews, but would like to know more about how we will help you outgrow job after job here at Electric Boat, write to Mr. Donald K. Whynott. Ask for our new informative brochure.

**GENERAL DYNAMICS**  
**Electric Boat Division**  
Groton, Connecticut

An Equal Opportunity Employer • U.S. citizenship is required



**JOE MENDELSON, PLANT ENGINEER**  
Ch.E., University of Maryland '63



**BILL OLDAKOWSKI, TECHNICAL ASSISTANT, HOT-STRIP MILL**  
Ind'l Admin., Yale University '63



## *They're on the move* at *Bethlehem Steel*

Have you heard about all the opportunities for engineers and other technical graduates at Bethlehem Steel? You'll find a great deal more information in our booklet, "Careers with Bethlehem Steel and the Loop Course." You can obtain a copy at your Placement Office, or drop a postcard to Manager of Personnel, Bethlehem Steel Corporation, Bethlehem, Pa. 18016.



*An equal opportunity employer in the Plans for Progress Program*

**JIM PFEIFFER, RESEARCH ENGINEER**  
Ch.E., Pennsylvania State University '62



**KARL KUGLER, COMBUSTION ENGINEER**  
M.E., State University of New York (Buffalo) '62



**CHARLIE MARTIN, ELECTRICAL ENGINEER**  
E.E., Lafayette '62

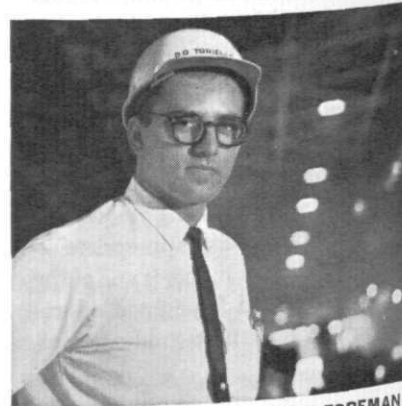

**DOM TORIELLO, OPEN-HEARTH FOREMAN**  
Met.E., Case Institute of Technology '63

# Industrial News

Flexible, jacketed glass fibers for light transmission in single lengths up to 10,000 feet are available from Corning Glass Works. The fibers are jacketed in tough plastic for ease in handling and for use in automated processing equipment. Corning flexible glass fibers can be twisted and flexed without interruption of light transmission. Applications for high temperature resistant glass fibers include transmission of remote light or optical data in instrumentation, processing, inspection, and illumination systems. Initial selling price is 10 cents per foot in quantities of 50,000 feet. As volume increases, the price will fall to five cents or less per foot, depending on quantity and specifications, Corning said.

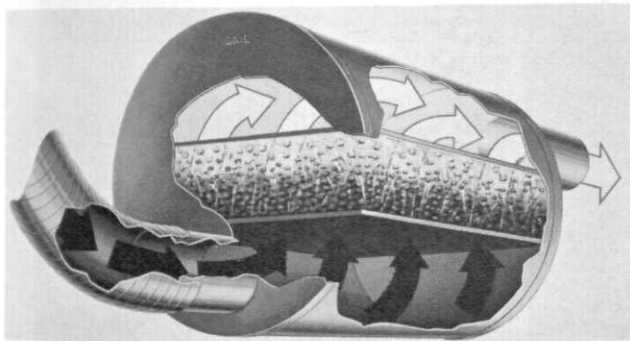

Here is a cutaway sketch of GMC Truck & Coach Division's new experimental catalytic muffler. Arrows indicate the flow of exhaust gases through a chamber containing ceramic pellets coated with a catalytic agent.

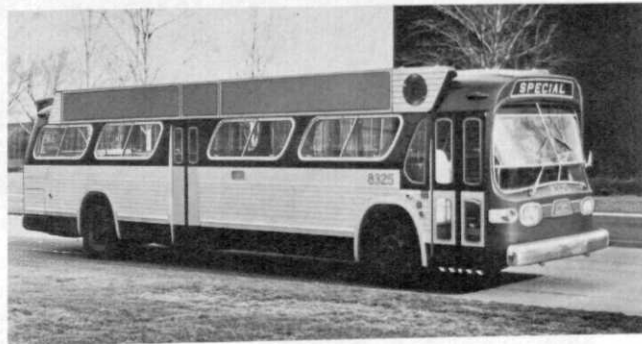

Ten transit buses similar to the one shown here are equipped with experimental catalytic mufflers for further evaluation in New York City's mass transportation system.

Ten buses equipped with experimental catalytic mufflers have been delivered to the New York City Transit Authority by GMC Truck & Coach Division of General Motors for further evaluation in the field of diesel bus exhaust odor control.

The vehicles were among the last of 682 GMC buses ordered by New York last fall in a long-range program to modernize its transportation system.

GMC Chief Engineer Harold O. Flynn said the muffler's catalyst consists of chemically coated ceramic pellets.

The flow of hot exhaust gases through the muffler activates the pellets to promote the oxidation of unburned hydrocarbons and also agitates them to reduce buildup in the catalytic bed.

Mufflers similar to those being placed in New York are being evaluated in several other selected bus fleets. In Detroit, they have operated for more than 40,000 miles without limiting engine performance or requiring the addition of new catalytic pellets.

In addition to the catalytic muffler development, Flynn said that GMC Truck & Coach Division is conducting research in other areas.

They include the investigation of fuel additives and masking agents, recirculation of exhaust gases, exhaust dispersion devices, after-burners, design of injection and combustion systems, air injection, air induction including swirl, engine lubricant efforts, and combustion chamber shapes.

He said development of the new experimental catalytic mufflers was a joint venture, with the W. R. Grace & Company of Baltimore, Md., supplying the catalyst and Nelson Muffler Company of Stoughton, Wisc., providing the mufflers.

**A SLICK WAY TO COUNT MONEY.** Between two Bell System coin telephones are Carolyn Choate, stacks of money, and small plastic parts. There's a logical connection. Carolyn is an employee of Western Electric's Oklahoma City plant, which makes coin telephones. Since the phones have but one slot for three coins (nickels, dimes, and quarters), there must be a way to identify the money inserted for a call. That's the job of the plastic parts, which are molded to tolerances as exact as 5/10,000th of an inch. They work together to send electronic "beeps" to the Bell System operator (one beep for a nickel, two for a dime, five for a quarter). A special plastic is used instead of metal so the parts are, in effect, self-lubricating. Western Electric engineers term it "a very low coefficient of friction." In other words, a slick way to count money.



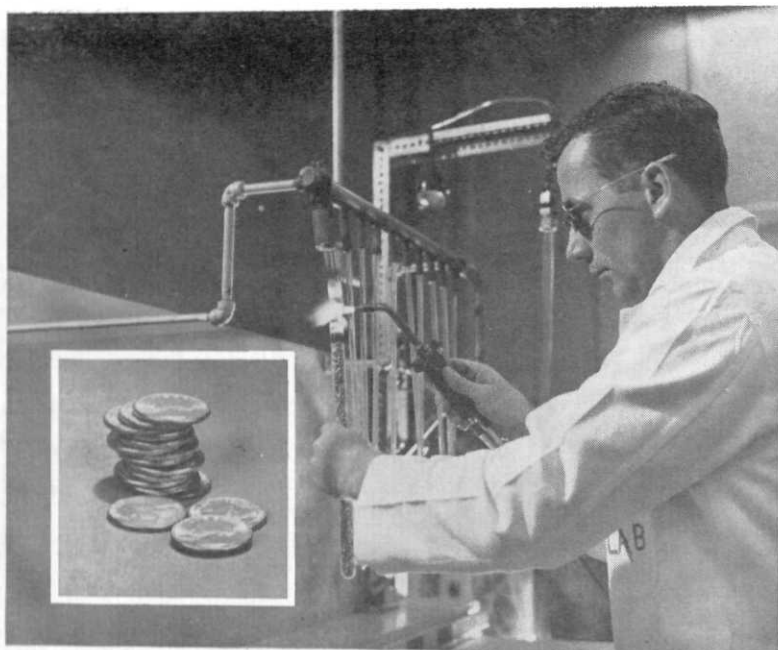

*metallurgical materials  
move ahead fast  
...so can you!*

**TI ALSO MOVES AHEAD FAST  
IN ...**



SPACE SYSTEMS

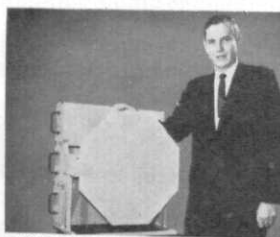

MICROELECTRONIC RADAR



DIGITAL SYSTEMS

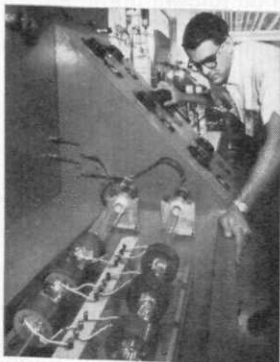

SEMICONDUCTOR MATERIALS



SEMICONDUCTOR INTEGRATED CIRCUITS



SIGNAL PROCESSING



COHERENT OPTICS

How do you make coin material — without silver — that a vending machine can't tell from a conventional silver quarter? How do you make a piece of wire with the electrical conductivity of copper and the tensile strength of steel? How can you provide a wearing surface equivalent to diamond at a small fraction of the price? These are the kinds of material problems you might work on at Texas Instruments. Materials scientists solve problems like these by cladding dissimilar metals together to form a new material that has properties unattainable with any monolithic alloy. Applied to such products as thermostats and controls, TI metallurgical skills solve problems like knowing when to turn off your coffee pot or when to stop a large industrial motor. Creative skills in materials and many other technologies have helped TI double in size about every three years for the past two decades. You might be interested in other TI technologies, a few of which are illustrated here. All have as a common bond a high level of innovation... by creative people working in a creative environment. TI's growth and diversity offer exceptional opportunities for outstanding college graduates at all degree levels and in many disciplines. For information about metallurgical materials at Texas Instruments — or any other technology illustrated here — write Jack Troster, indicating your area of interest. To obtain information about current professional openings, consult your college placement director, or send your confidential resume to Jack Troster, Dept. C-482, P. O. Box 5474, Dallas, Texas 75222. An equal opportunity employer.

**TEXAS INSTRUMENTS  
INCORPORATED**

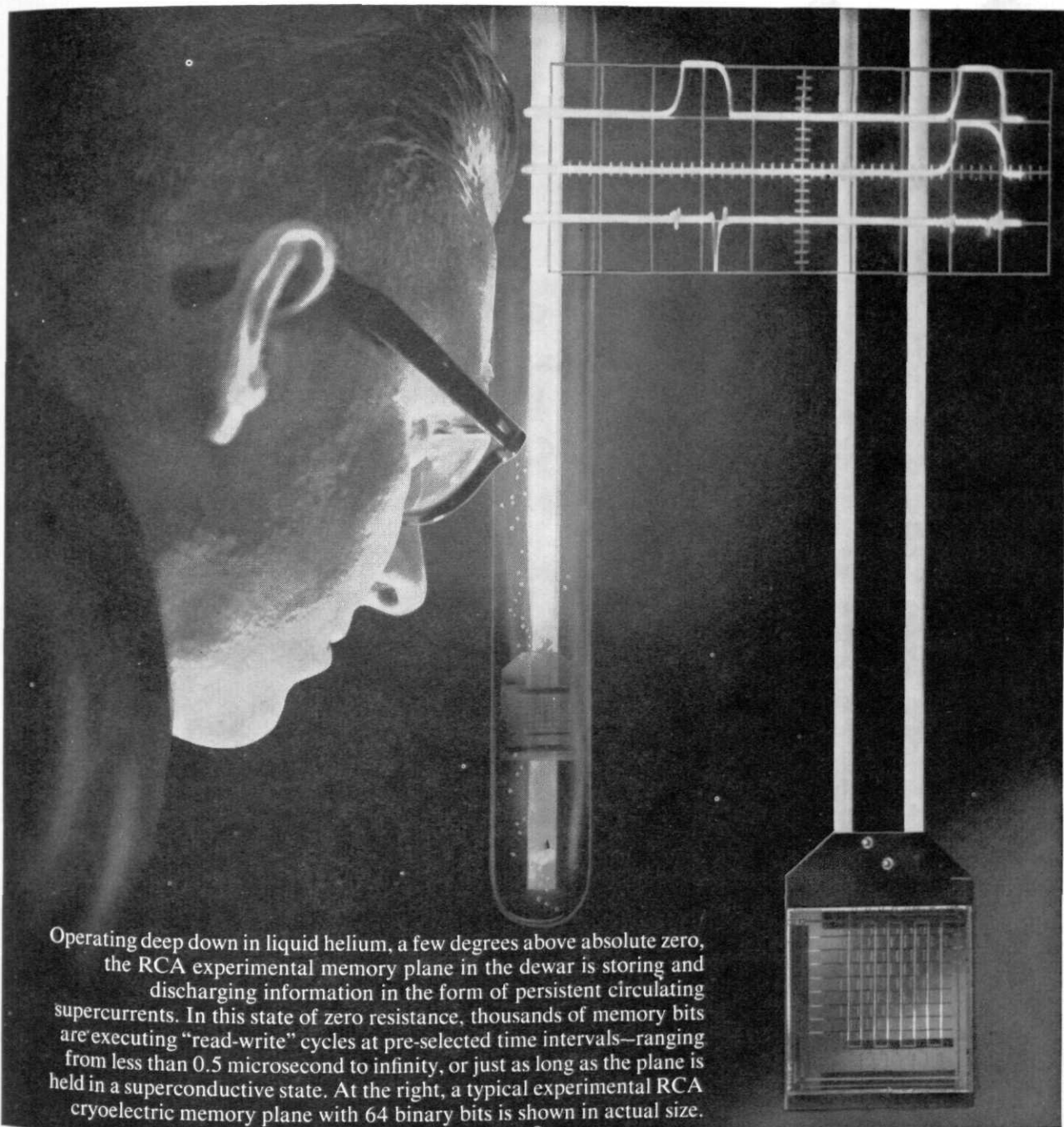

Operating deep down in liquid helium, a few degrees above absolute zero, the RCA experimental memory plane in the dewar is storing and discharging information in the form of persistent circulating supercurrents. In this state of zero resistance, thousands of memory bits are executing "read-write" cycles at pre-selected time intervals—ranging from less than 0.5 microsecond to infinity, or just as long as the plane is held in a superconductive state. At the right, a typical experimental RCA cryoelectric memory plane with 64 binary bits is shown in actual size.

## RCA Knows How in *Electronic Components and Devices*

You are facing a very important decision. When you select the company that you want to join, consider how important it is for your future career to join the leader. For example, in this one area alone—Electronic Components and Devices—you will find that RCA has set standards of engineering excellence, in an environment for learning, that is second to none.

EE, ME and IE opportunities exist for *all* degree levels in every phase of research, design and development, information systems, manufacturing, computer marketing, and purchasing with RCA.

Another consideration — we believe in individual growth. There are training programs, graduate education programs, and in-house courses—all designed to encourage your individual development and growth.

In addition, you will work in a distinguished scientific and engineering environment.

You owe it to yourself to find out more about the great range of activities at RCA. See your college placement director, or write to College Relations, Radio Corporation of America, Cherry Hill, New Jersey 08101.

Whatever your field of interest—we would like to hear from you.

*An Equal Opportunity Employer*



**The Most Trusted Name in Electronics**

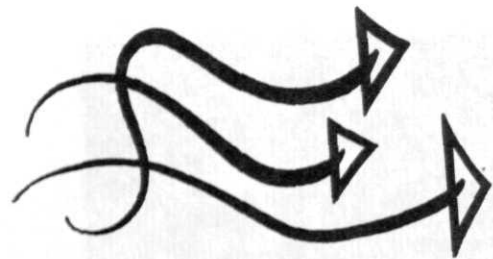

## NUTCH

*What lust hath the lowly jellyroll,  
None more banal than a stale fig newton,  
Sincerity is a soggy oreo,  
Extinction the belly button of an oatmeal cookie.*

Jack Simmons

## ODE TO A GROUND WIRE

*Oh to thee oh ground wire,  
You cover me when I need you;  
Like my mother of the womb,  
You are totally fundamental,  
Basic*

*You are the commonest,  
Not even the Marxian Proletariat  
Cover the chassis like you.*

*To be positive and negative  
At different times;  
Only you, Only you;  
Can be at once once,  
Then neether niither later.*

*To be in the nitty-gritty,  
Down in the earth  
Strong, sweet, brown and fundamental,  
Earth  
Your brothers capacitor,  
Resistor, or semi-conductor  
Never get down THERE*

*To be isolated in the cabinet;  
Yet be so Ontologically there,  
In the case, but out  
In the earth:  
So Earthy is to  
BE*

John Henry Dekker

# POEMS

*THERE NEVER WAS A TRUER LOVE,  
THAN NEVER WAS.*

Jack Simmons

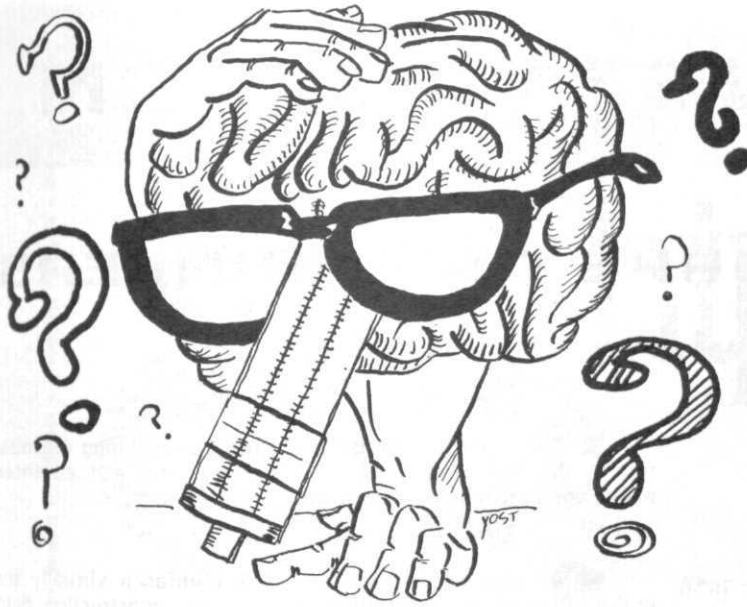

# BRAIN SPRAINERS

Editors note: Answers to the following problems will appear in the May issue.

1. Find the digit represented by each letter in this multiplication problem. No two letters represent the same number and no letter represents two numbers.

LYNDON

B

JOHNSON

2. Below are given three sets of numbers. In each set the second number is derived from

the first by some general rule which holds for the entire group. Find the general rule and the number to go with the last pair in each set.

- a) 5-52, 6-63, 7-94, 9-18, 8-?
- b) 5-56, 6-87, 7-19, 8-401, 9-?
- c) 11-121, 12-144, 13-169, 14, 1861, 16-1273, 15-?

3. How many multiples of 11 are there from one to one trillion that are even and also squares?

Answers to January's Problems

1. Smith forgets to bring his wife flowers; there is no in-

dependence.

2. Both fighters flew the same distance, 400 miles, since each flew for 240/300 hours during the operation.
3. 6 cuts. No matter how the cutting is done, the faces of the central cube must result from separate cuts. The job may be done without any piling.
4. The garrison had 49,500 lbs. of bread.
5. The computation is in the duodecimal scale (to the base 12), so  $1/5$  of 10 is  $2 \frac{2}{5}$ .
6. Not always.

## The Engineer's Psalm

Dr. \_\_\_\_\_ is my instructor;  
I shall not pass.  
He maketh me to exhibit mine ignorance before the whole class.  
He telleth me more than I can write.  
He lowereth my grade.  
Yea, though I walk through the corridors of knowledge, I do not learn.  
He tries to teach me;  
He writeth the equations before me in hopes I will understand them.  
He bombardeth my head with integrations,  
My sliderule freezeth up,  
Surely enthalpies and entropies shall follow me all the days of my life,  
And I shall dwell in the College of Engineering forever.





# CONSTRUCTION

## THE ARMY CORPS OF ENGINEERS

offers you a challenging civilian career with:

■ The world's foremost and largest engineering organization in the construction field, pioneering new and advanced engineering practices and concepts.



■ An organization whose work embraces virtually the entire range of modern engineering in the construction field. Projects include research into basic science, engineering investigations and regional planning; design, construction, operations, maintenance, and management of hydro-electric power dams, flood control facilities, harbors and navigable streams; design, construction and maintenance of family housing, runways, hangars, roadways, hospitals, and nuclear power installations; and construction of intercontinental ballistic missile and space launching sites. In addition are the allied fields of cartography, geodesy, mathematics, and engineer intelligence.

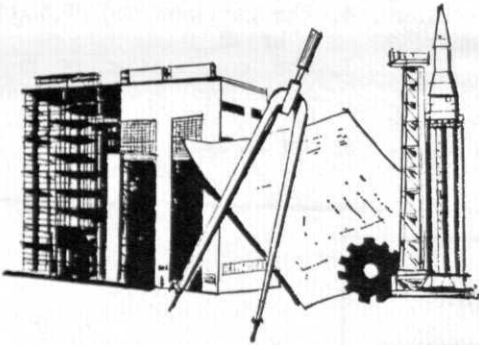

■ An organization that recognizes each engineer as an individual, providing well-rounded career development programs with on-the-job training; courses at government expense in colleges, universities, and seminars as necessary to assure steady progression to top professional and managerial levels; encouragement and assistance in attaining professional registration and recognition; and an opportunity to win national and international awards.

■ An organization with offices and projects in nearly every one of the 50 States and in many foreign countries that encourages employees to further their development by accepting new and challenging assignments.

■ An organization which provides excellent rates of pay with liberal fringe benefits, including generous retirement annuity, complete health and life insurance coverage, paid vacation leave, military training leave with pay, generous sick leave; and special pay awards for outstanding performance and suggestions that improve operating efficiency.

If you're thinking this all too good to be true, you're wrong! All of the above is available to you in a civilian engineer career with the U. S. Army Corps of Engineers. If you are interested, you can get further information from the Chief of Engineers, Department of the Army, Washington, D.C. 20315.

**AN EQUAL OPPORTUNITY EMPLOYER**

**WRITE FOR AN ILLUSTRATED BROCHURE "YOUR CAREER."**

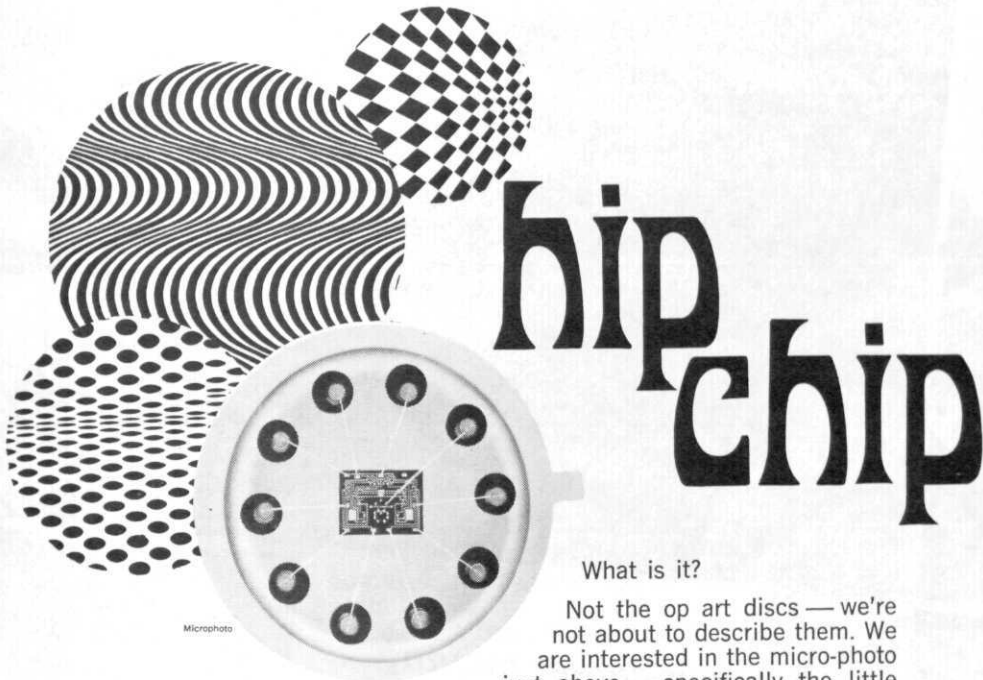

# hip chip

What is it?

Not the op art discs — we're not about to describe them. We are interested in the micro-photo just above — specifically the little rectangle in the center. It's a minuscule chip of silicon produced in Motorola's semiconductor labs—on the verge of creating a scientific revolution all its own.

The chip's dimensions are 0.060" by 0.080"—about the size of a baby B-B. That tiny area incorporates 14 transistors, 10 resistors and 2 capacitors—performing the same circuit functions as the 26 discrete components shown below. It's Motorola's chip off a new block of electronics—it's an integrated circuit.

But why all the fuss?

Because the integrated circuit is the key to untold electronics marvels, hitherto impractical. Because its small size, weight, and power consumption lessen the cost of complex systems and improve performance. Because it's more reliable, to boot.

Integrated circuits already are used in design plans for amazing new computers — computers which will, in effect, function as special extensions of the human brain. Computers which, in time, will almost think. It's an exciting business. It challenges everyone in it.

Within a year, the solid state art will develop the means to store the content of the Encyclopaedia Britannica in a one inch cube—a solid state memory system. One day, every important university library will have electronic knowledge banks connected, perhaps by satellite, for instant exchange of information.

People generally are impressed by the chip with 26 components. But hang on. We've now got one in the lab not much larger (0.120" by 0.120") . . . with 524 components!

Hip chip? You bet.

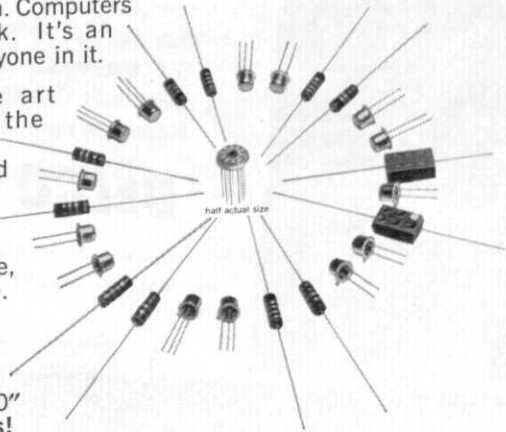

TRUST THIS EMBLEM



WHEREVER YOU FIND IT

**MOTOROLA**

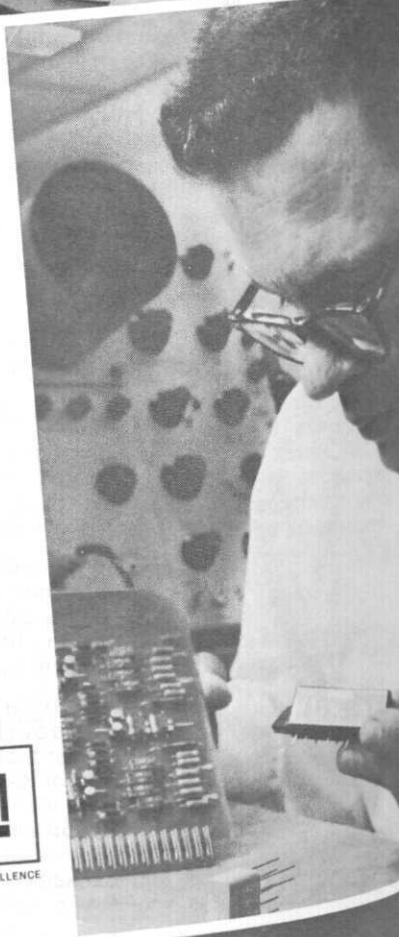

## *Get your career moving*

Get together with Delco Radio, the mover in electronics. Make no mistake—the pace is fast and demanding. But our people thrive on it. They're having a ball, pushing the state of the art clear out of sight in microelectronics and silicon devices. New research programs . . . new products . . . new equipment . . . and plenty of new opportunities for new people. Electrical Engineers. Mechanical Engineers. Physicists. Metallurgists. Physical Chemists.

Challenge—benefits—salary—community. You'll find 'em all at Delco. Get your career moving now! Get together with our interviewers when they visit your campus. Better yet, drop a line to C. D. Longshore, Supervisor, Salaried Employment, Delco Radio Division, General Motors, Kokomo, Indiana. An equal opportunity employer.

# **DELCO RADIO**

Division of General Motors,  
Kokomo, Indiana



# ENGRINEERS

She (cooly): "You bad boy, don't you kiss me again."

He: "I won't. I'm just trying to find out who has the gin at this party."

WENCH: Something to turn the head of a dolt.

They arrested her for soliciting, but she pleaded not guilty, claiming she was only calling her dog Tiz. . . . "Here Tiz, Here Tiz."

SE

A fugitive scientist from a Boris Karloff horror picture dreamed up a serum that would bring inanimate objects to life. He surreptitiously tried it out on the statue of a great general in Central Park. Sure enough, the statue gave a quiver and a moment later the general, creaking a bit in the joints, climbed down from the pedestal. The scientist was overjoyed.

"I have given you life," he exulted. "Now tell me, General, what is the first thing you are going to do with it?"

"That's easy," rasped the general, ripping a gun from his holster. "I'm going to shoot about two million pigeons."

SE

She has a contagious smile. . . trench mouth.

SE

The little girl was sitting demurely on the couch, watching her mother smoking a cigarette. Her little nose was wrinkled and in her pale blue eyes was an expression of disillusionment. Finally, unable to stand it any longer, she burst in her quavering falsetto:

"Mother, when in the hell are you going to learn to inhale?"

"Why that toothbrush in your coat lapel?"

"It's my class pin -- I go to Colgate."

SE

Chem. E.: "May I take you home? I like to take experienced girls home."

Coed: "But I'm not experienced."

Chem. E.: "You're not home yet either."

Did you hear about the engineer who tried to beat a train to the railroad crossing?

He hit the 29th car.

SE

The GIs were searching a village just after the battle of WWII. Entering a large house they found a coffin in the middle of the room. Opening the coffin they found an old grey haired man sadly erasing a musical manuscript. When questioned who he was and what he was doing, the old man replied: "I'm Beethoven, and I'm decomposing."

No man is completely worthless, he can always serve as a horrible example.

SE

"And then I said, 'Well, if I can't make it in industry, I can always teach.' Then the prof stopped laughing."

SE

"Beg your pardon, but aren't you an engineering student?"

"No, it's just that I couldn't find my suspenders this morning, my razor blades were gone, and a bus ran over my hat."

A jealous husband returned home early from a business trip and found his wife in the undress.

"There's a man in the house," he said searching every room. When he went into the bathroom he discovered a shadow hiding behind the shower curtain. Immediately he opened it and found a man standing in the tub. The man jerked the curtain closed again.

"Please," he said, "I haven't finished voting yet."

SE

She was a gorgeous girl, And he was a loving male. He praised her shape in English, French, Italian, and Braille.

Then there was the one-fingered pick-pocket who could only steal lifesavers.

SE

"I'll bet you can't tell me why they don't allow Volkswagens in Africa."

"I give up, why don't they allow Volkswagens in Africa?" "Because wild elephants will make love to anything with a trunk in front."

How about a 23-hour deodorant? A guy should have at least one hour to himself.

SE

The young father was explaining a sure-fire method for putting the baby to sleep.

"I toss him up in the air again and again."

"How does that put him to sleep?" asked the neighbor

"We have very low ceilings."

SE

CONTINUED FROM PAGE 11

they are linked to the One responsible for them. Actually the biblical truths do not find an enemy here but they are fortified and explained further by the discoveries we have made. This has given me an added incentive in my studies here in school.

The preceding all seems very reasonable to me but to some it is not so. Usually opposition will come from those who have not looked into these things and as a result they have no answer except that of denying or refuting. It is my studied conviction that God's claim on my life is valid and that His call to me is sincere. To deny this claim or call is to place oneself in a dangerous position, the clay does not say to the potter, "No." I do not claim to have all the answers but the most important question has been answered: I KNOW WHOM I HAVE BELIEVED AND AM PERSUADED THAT HE IS ABLE TO KEEP THAT WHICH I HAVE COMMITTED UNTO HIM AGAINST THAT DAY.

*It is in process* - So wrapped in red tape that the situation is almost hopeless.

*We will look into it* - By the time the wheel makes a full turn, we assume you will have forgotten about it.

*A program* - Any assignment that can't be completed by one telephone call.

*Expedite* - To confound confusion with commotion.

*Channels* - The guy who has a desk between two expeditors.

*Consultant (or Expert)* - Any ordinary guy more than 50 miles from home.

*To activate* - To make carbons and add more names to the memo.

*To implement a program* - Hire more people and expand the office.

*Under consideration* - Never heard of it.

*Under active consideration* - We are looking in the files for it.

*A meeting* - A mass mulling by masterminds.

*A conference* - A place where conversation is substituted for the dreariness of labor and the loneliness of thought.

*To negotiate* - To seek a meeting of minds without a knocking together of heads.

*Re-orientation* - Getting used to working again.

*Reliable source* - The guy you just met.

*Informed source* - The guy who told the guy you just met.

*Unimpeachable source* - The guy who started the rumor originally.

*A clarification* - To fill in the background with so many details that the foreground goes underground.

*We are making a survey* - We need more time to think of an answer.

*Note and initial* - Let's spread the responsibility for this.

*See me or let's discuss* - Come down to my office, I'm lonesome.

*Let's get together on this* - I'm assuming you're as confused as I am.

*Give us the benefit of your thinking* - We'll listen to what you have to say as long as it doesn't interfere with what we have already decided to do.

*Will advise you in due course* - If we figure it out, we'll let you know.

*Take some dictation* - Come on over honey and we'll talk.

*To give someone the picture* - A long confused and inaccurate statement to a newcomer.

*Point up the issue* - To expand one page to fifteen pages.

*We are aware of it* - We had hoped that the fool who started it would have forgotten about it by this time.

*Confidential* - Spy bait and besides the stamp looks important.

*Restricted* - Uncle Joe already has it, and we are waiting to see if he can make any sense out of it.

*With modifications* - Will be shipped to you in kit form - put it together (if you can) yourself. Glue optional.

*Interpretation* - Your warped opinion pitted against your advisory's good sense.



# FREEDOM OF SHAPE...

One of the outstanding advantages of Malleable Iron Castings

Casting is the simplest and most direct way of creating form and shape with metal. Casting offers almost unlimited freedom to the designer. A cast design is not restricted by sizes or shapes of mill stock, accessibility of tools, withdrawal allowances for dies, or other limitations. Complex shapes, interior cavities, and streamlined contours, which would be difficult or impossible to create with other methods, are simple with a casting.

For instance, consider the complexity of creating the dozens of teeth, lugs, holes and collars on this pipe repair clamp. It

would be prohibitively expensive to produce by any method other than casting. By using the casting process for economy,

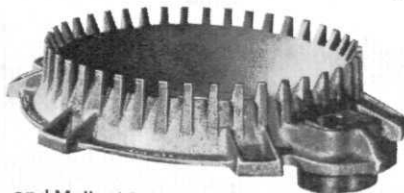

and Malleable iron for strength and ductility, these clamps combine service and value.

The design freedom made possible by

casting also helps to make parts stronger. Metal components tolerate loads better if they are designed to distribute stresses efficiently. Sharp corners or other abrupt sectional changes tend to restrict the uniform distribution of these stresses. The corner thus becomes a logical site of fatigue failure. In a casting, it is a simple matter to round out corners, blend sections and taper connecting members to achieve a design which will distribute stresses.

The illustration shows how stresses "set up" at sharp corners. A much smoother transfer of stresses was achieved when this part was switched to a Malleable casting (shown on the right).

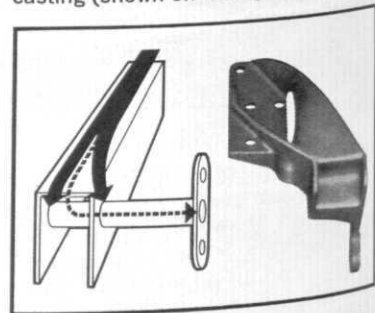

MALLEABLE FOUNDERS SOCIETY • UNION COMMERCE BUILDING  
CLEVELAND, OHIO 44115

In the next few years, Du Pont engineers and scientists will be working on new ideas and products to improve man's diet, housing, clothing and shoes; reduce the toll of viral diseases; make light without heat; enhance X-ray diagnosis; control insect plagues; repair human hearts or kidneys; turn oceans into drinking water...



## and anything else that you might think of.

The 165-year history of Du Pont is a history of its people's ideas—ideas evolved, focused, and engineered into new processes, products and plants. The future will be the same. It all depends upon you.

You're an individual from the first day. There is no formal training period. You enter professional work immediately. Your personal development is stimulated by real problems and by opportunities to continue your academic studies under a tuition refund program.

You'll be in a small group, where individual contributions are swiftly recognized and rewarded. We promote from within.

You will do significant work, in an exciting technical environment, with the best men in their fields, and with every necessary facility.

Sign up today for an interview with the Du Pont recruiter. Or mail the coupon for more information about career opportunities. These opportunities lie both in technical fields—Ch.E., M.E., E.E., I.E., Chemistry, Physics and related disciplines—as well as in Business Administration, Accounting and associated functions.



E. I. du Pont de Nemours & Co. (Inc.)  
Nemours Building 2500—1  
Wilmington, Delaware 19898

Please send me the Du Pont Magazine along with the other magazines I have checked below.

- Chemical Engineers at Du Pont
- Mechanical Engineers at Du Pont
- Engineers at Du Pont
- Du Pont and the College Graduate

Name \_\_\_\_\_  
Class \_\_\_\_\_ Major \_\_\_\_\_ Degree expected \_\_\_\_\_  
College \_\_\_\_\_  
My address \_\_\_\_\_  
City \_\_\_\_\_ State \_\_\_\_\_ Zip Code \_\_\_\_\_

# THE ADVERTISER'S INDEX

AIR FORCE . . . . .	40
ALLISON . . . . .	1
AMERICAN OIL . . . . .	2
ANACONDA . . . . .	7
ARMY ENGINEERS . . . . .	32
BABCOCK & WILCOX . . . . .	16
BETHLEHEM STEEL . . . . .	26
CELANESE . . . . .	15
COLLINS . . . . .	12
DELCO . . . . .	34
DUPONT . . . . .	37
FORGING INDUSTRY . . . . .	6
GARRETT . . . . .	4
GENERAL DYNAMICS . . . . .	25
GENERAL ELECTRIC . . . . .	Back Cover
INTERNATIONAL HARVESTER . . . . .	8
KODAK . . . . .	Inside Back Cover
MALLEABLE FOUNDERS . . . . .	36
MOTOROLA . . . . .	33
NATIONAL CASH REGISTER . . . . .	10
PRATT AND WHITNEY . . . . .	20 & 21
RCA . . . . .	29
SUNDSTRAND . . . . .	24
TEXAS INSTRUMENTS . . . . .	28
TIMKEN . . . . .	39
UNION CARBIDE . . . . .	13
WESTERN ELECTRIC . . . . .	22
WESTINGHOUSE . . . . .	Inside Front Cover
XEROX . . . . .	17



## OUR MAN IN OFFSHORE DRILLING

# IS HE YOU?

Wherever a well sucks oil from the earth, you're apt to find our man's ideas.

Timken Company metallurgists have worked with petroleum engineers to develop seamless steel tubing that today's highest well pressures won't pop.

It's used for drill collars, tool joints, lots of other "down hole" applications.

The petroleum industry counts on the uniform quality of Timken® steel tubing. And we count on our engineers to keep it that way.

Could we count on you? Are you interested in meeting industry's demands for finer metals . . . and finer minds?

Then clip the coupon and send today for

the free booklet, "Place Your Future on a Sound Foundation." Maybe *you* are our man in offshore drilling?

The Timken Roller Bearing Company,  
Canton, Ohio.

An Equal Opportunity Employer.

Mail to: Manager of College Relations  
The Timken Roller Bearing Company  
Canton, Ohio 44706

Rush me a copy of your free booklet,  
"Place Your Future on a Sound Foundation."

Name \_\_\_\_\_

Address \_\_\_\_\_

School \_\_\_\_\_

Year \_\_\_\_\_ Major \_\_\_\_\_



# The Air Force doesn't want to waste your college education any more than you do.

Are you afraid of becoming part of the woodwork on a job? Your career stunted by boredom? Few promotions in sight?

You didn't go to college for that.

And it needn't happen, either. Because you can pick the United States Air Force as your employer. Career opportunities are so vast... you'll get a better chance to specialize where you want...in the forefront of modern science and technology.

Suppose, just for example, you wanted to be involved in Electronics. This area alone includes Communications-Electronics, Missile Electronics, Avionics, and others. And these, in turn, involve administrative, research, and other technical aspects.

That's just a tiny part of the whole Air Force picture. Just one brilliant opportunity area among many.

You'll enjoy good pay, promotions, chance to travel, active social life, fine retirement benefits. And you'll be serving your country, too.

Or maybe you want to fly? That's great. The Air Force is certainly the place to do it.

As a college graduate you want something extra out of life—to aim at an exciting goal. So send in this coupon.

Make sure you don't get stuck where nothing much is happening.

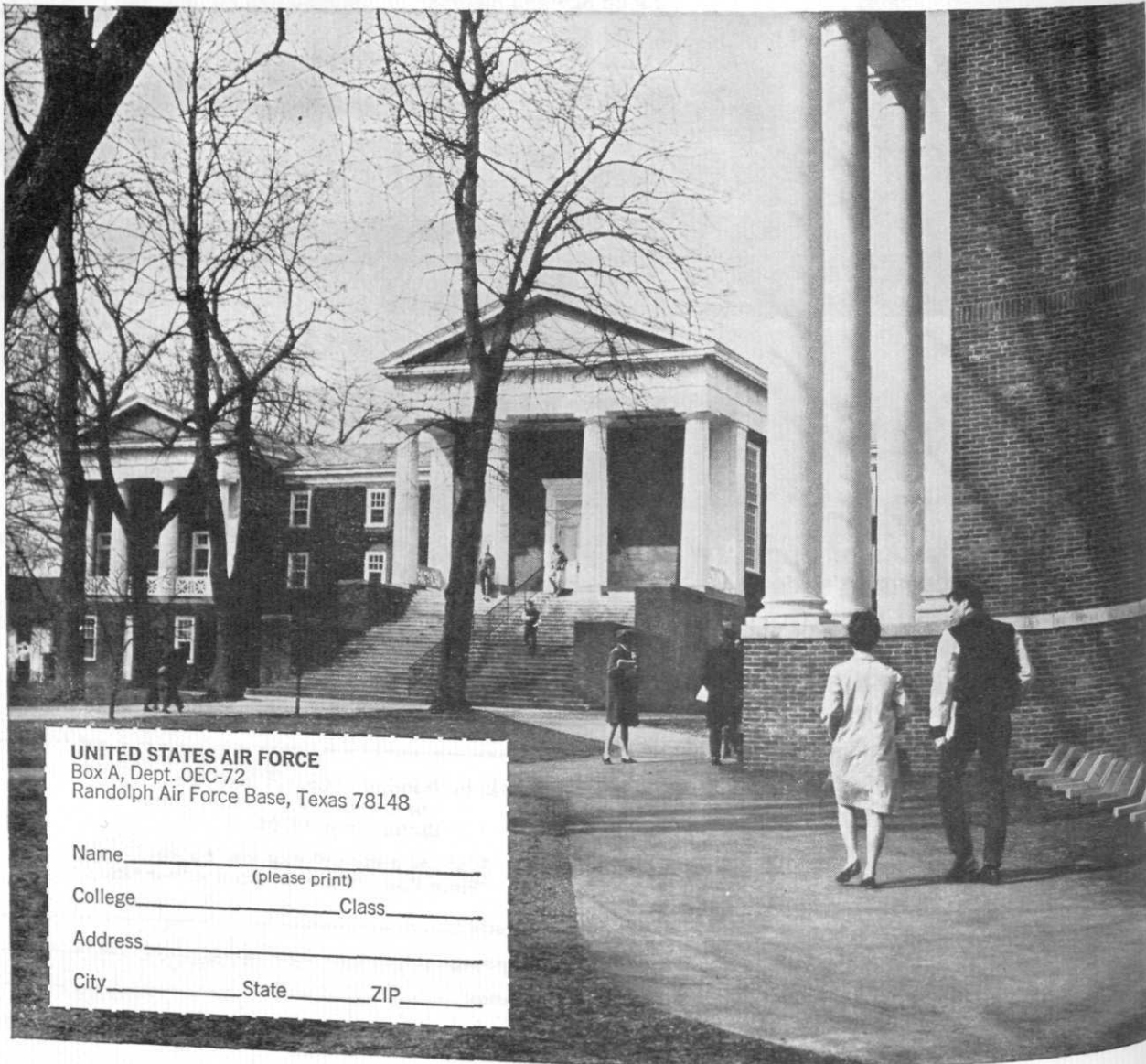

**UNITED STATES AIR FORCE**  
Box A, Dept. OEC-72  
Randolph Air Force Base, Texas 78148

Name \_\_\_\_\_  
(please print)

College \_\_\_\_\_ Class \_\_\_\_\_

Address \_\_\_\_\_

City \_\_\_\_\_ State \_\_\_\_\_ ZIP \_\_\_\_\_

Some say that the campus has become too academic to meet industry's engineering manpower needs.

***That's nonsense.***

Semiconductor catalysis  
Diffusion rates in molecular sieves  
Surface diffusion of chemisorbed species  
Interaction of antagonistic polyelectrolytes

Polyelectrolyte complex films as reverse osmosis membranes  
Rheology of non-Newtonian fluids  
Blood flow in the microcirculation  
Mass and momentum transfer in a boundary layer

Above are a few of the research projects under way in the chemical engineering department of one of the prestigious science universities. Once upon a time that institution was considered an engineering school. *Now* look at it.

The reason we print the list is that it happens to name some topics for which we need chemical engineers to solve some all too real problems of our photographic business.

We would be less than candid, however, if we implied we require all our chemical engineers to be academically minded. We have rewarding work for many types of minds. That simple fact is



In Rochester, N. Y., we make photographic and non-photographic products. In Kingsport, Tenn., our Tennessee Eastman Company makes fibers, plastics, and industrial chemicals. In Longview, Tex., our Texas Eastman Company does petrochemistry. All in all, an equal-opportunity employer offering a broad choice of professional work and living conditions.

**Or is it?**

the payoff (to the individual chemical, mechanical, electrical, or industrial engineer) from our size and diversification. He gets *choice*.

The first job he chooses may seem to represent his personal bent. It may represent nothing more than a direction in which he has been pointed by his professors. A few years of actual experience may show a young engineer that he is less "thing"-oriented than he thought he was and more interested in relating "things" to people than he was taught to be—supervision, marketing, technical liaison, etc.

To offer choice at the outset and choice later fits in well with our principle that a man or woman isn't just part of a department or project but is working for a far more important entity known as Eastman Kodak Company, which had better make the biggest possible personal success of him or her if it wants to realize a fair return on its investment.

By the way, you may not realize that we are involved in a lot more than photography (which hasn't stopped booming for 80 years) and find the other businesses pretty good, too.

Correspondence welcomed by EASTMAN KODAK COMPANY, Business and Technical Personnel Department, Rochester, N. Y. 14650.

**Kodak**  
TRADEMARK

**General Electric  
engineers and scientists  
are helping to satisfy the  
needs of society...**

**like beautiful cities**



A technical career at General Electric can put you in the position to help beautify our cities.

Inquisitive minds in research and advance development at G.E. are evolving many concepts to give our cities a clean, all-electric look. Design engineers are translating concepts into components and systems, while manufacturing engineers are developing the methods and machines that bring designs into being as useful products.

Technical marketing specialists are working with electric utilities and city planners to give mushrooming urban landscapes like Phoenix, Atlanta and Chicago, a bright, all-electric face.

Urban living has already begun to change as a result of the contributions made by General Electric engineers and scientists, contributions like air and water purification systems, underground power equipment to preserve nature's beauty, all-electric heating facilities, rapid-transit systems, and a hundred more.

You can help develop new products and concepts, new facilities, processes, and manufacturing systems, or new applications and markets in your technical career with General Electric. For more information write: D. E. Irwin, Section 699-20, Schenectady, New York 12305.

**GENERAL  ELECTRIC**

An Equal Opportunity Employer