

SPARTAN ENGINEER

JANUARY, 1965

36

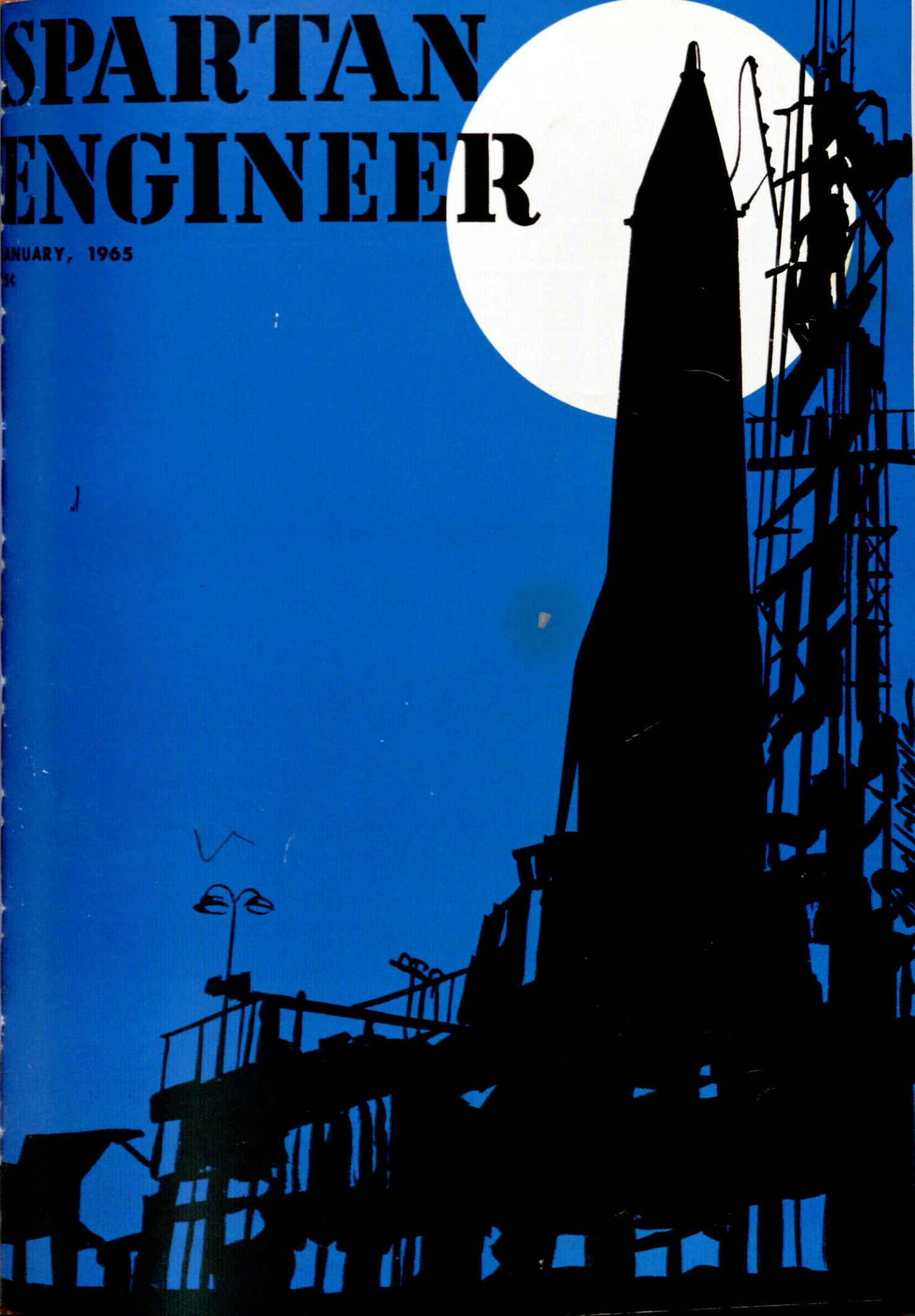

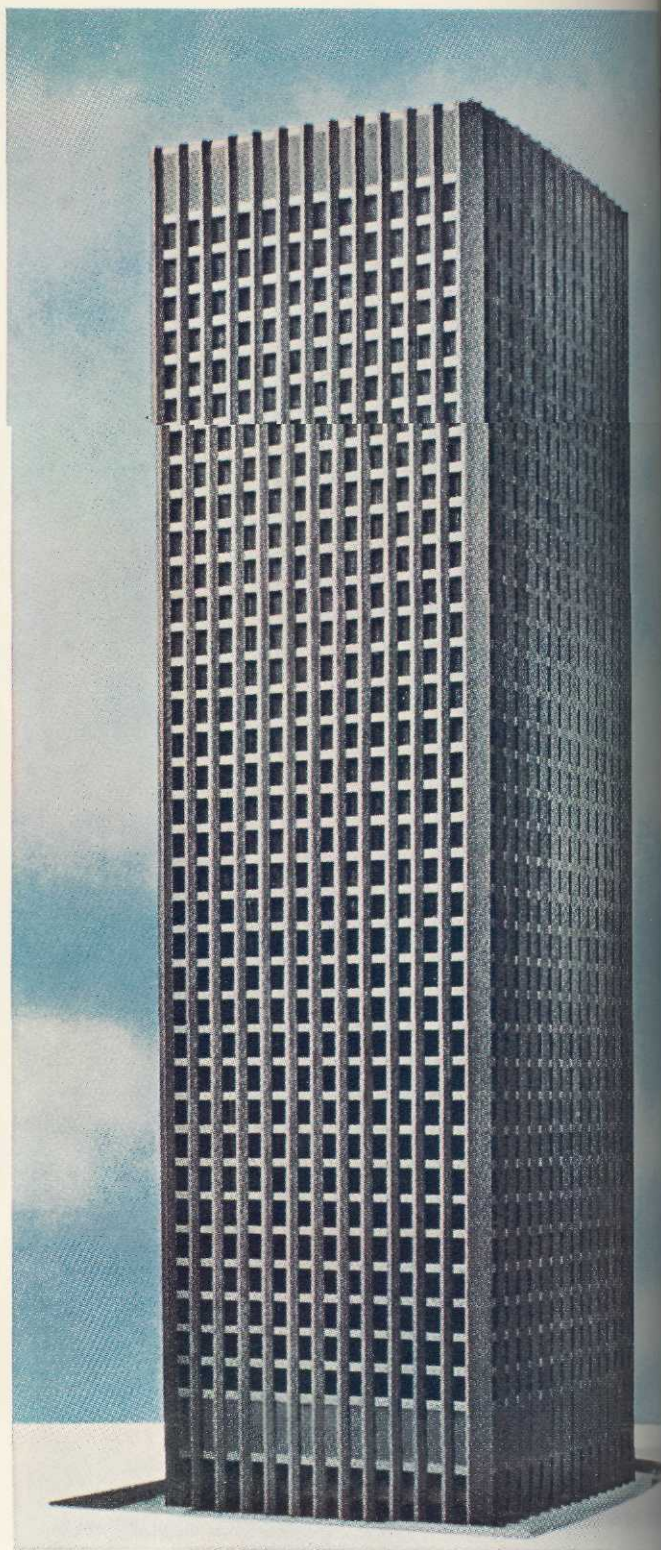

How will the stars get to the top at CBS?

On 16 new Westinghouse elevators.

The world's brainiest elevators are going into the new CBS Headquarters building in New York. They're Westinghouse Selectomatic Mark IV's.

They "think" their way to your floor.

They don't believe in keeping you waiting for needless trips to top or bottom. They'd rather wait for you somewhere in-between.

When you ring, an electronic brain sends them instantly to your floor.

Westinghouse Mark IV elevators get you 30% sooner than the most efficient elevators ever could before. That's why they're the quickest way to the top at CBS—and 163 other buildings across America.

You can be sure if it's Westinghouse



For information on a career at Westinghouse, an equal opportunity employer, write L. H. Noggle, Westinghouse Educational Department, Pittsburgh, Pa. 15221.

We need



AERO ENGINEERS

To design high-performance re-entry systems and solve basic problems in theoretical & experimental hydroballistics . . .

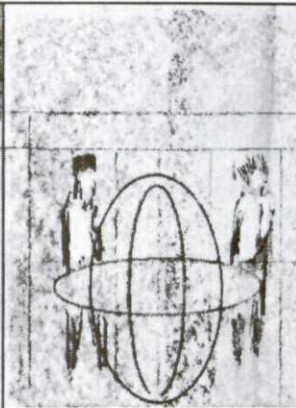

MECHANICAL ENGINEERS

To design missile components for nuclear arming and safing; pressure, temperature and spin sensors; timers & programmers; and to evaluate weapons environments and structures . . .

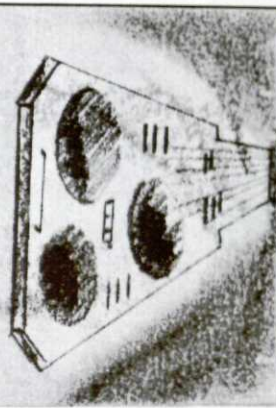

ELECTRICAL ENGINEERS

To design instrumentation for aeroballistic research; to develop portions of a new underwater communications or advanced submarine detection system; to solve fire control & guidance problems; and to perform circuit analyses . . . and

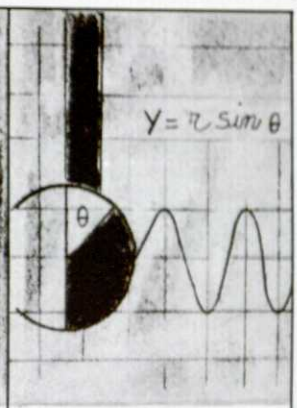

MATHEMATICIANS

To conduct numerical analyses, programming, and trajectory plotting.

but we want Tau Beta Pi types or equivalent!

Of course, every employer WANTS the cream of the crop, but the point is: we can get them! Not because of money or blue sky promises or "Extra" benefits, but because the Naval Ordnance Laboratory offers the best opportunity for vital research work in a near academic environment. (Some graduate degree courses are actually held here at NOL, and this is prime ground for PhD theses, as you may know.) Fact is, *some 40% of those graduates we hired last year were Tau Beta Pi members*, so you can understand our obvious pride.

The Naval Ordnance Laboratory takes the lead in the research, design, development, and test of all kinds of weapons systems and devices . . . ranging from the smallest arming circuit to a complete underwater-to-air-to-underwater nuclear missile system. (Not only was the SUBROC missile itself conceived and developed at NOL, but also its long-range sonar detection system and its digital computer fire control system.)

The NOL campus includes over 100 buildings on 900 acres of suburban countryside just outside Washington. The annual budget for *in-house research* averages some \$30 MILLION, and our facilities are the finest in the world. *But hypersonic wind tunnels, pressurized ballistic ranges, 2,000,000 gallon hydro-*

dynamics tanks, Mach 20 shock tunnels, 10-million volt x-ray equipment, IBM-7090's and all the other material benefits don't make a research laboratory.

It's the pervading intellectual atmosphere . . . the freedom to think and create . . . the encouragement to better oneself that sets NOL apart. For instance, we want engineers (and engineering-oriented physicists) who are willing to push an idea from original design straight through to prototype testing out at—or beneath—the sea. We want people who are interested in our excellent advance-degree program, and in associating with recognized authorities on a day-to-day basis. We want people who will take advantage of what the Washington area has to offer—people who live the full life.

If this appeals to you—whether you are Tau Beta Pi material, or even a guy with unfulfilled genius—drop by your College Placement Office to arrange an interview with an NOL representative. Or, write direct to Mr. L. E. Probst, Professional Recruitment Division, with your specific questions.



NOL

U.S. Naval Ordnance Laboratory,
White Oak, Silver Spring, Maryland

NOL is an Equal Opportunity Employer

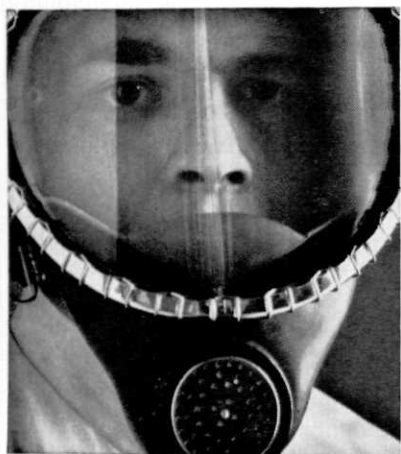

They're on the job for Olin.

Want to join them?

Take the masked man on the left, for instance. He's actually a pharmacologist on the job in one of our Squibb Division labs, testing out some pungent material behind a sniff-proof mask. Take a job with us doing biochemical research and you'll join him. You might even *be* him; behind those masks, who can tell?

The man in the middle? He's Nai Charden, a loyal, worthy and trustworthy fertilizer tester for our International Division. He works in the rice paddies around Nongkam (Thailand), helping Olin men check out the effectiveness of various grades of Ammo-Phos® fertilizer.

And then there's Casper. (One of our Winchester boys gave him the name during the last 20 seconds of his [Casper's] life.) Casper is (was) on the job for Olin, too, although he wasn't actually on the payroll. Unwittingly, he helped an Olin team in darkest Africa to test out the new line of sporting arms from our Winchester-Western Division.

Sounds interesting?

Well, there's a hedge, of course.

We can't promise, for example, that the minute you're off campus you'll be on safari. And we're not saying you'll walk out of your dorms and into the jungle.

What we are offering is a unique chance to pick your career out of an incredibly wide spectrum of opportunities in specialized fields: engineering,

science, liberal arts, business administration—you name it.

And we are definitely offering you a chance to train and work with some of the sharpest people in your field (native scouts and target lions notwithstanding). You will pick up right where you leave off at graduation and, with crack specialists, start probing the intricacies of your special area. Most important, you will learn by *doing*. (At Olin, a guy is always learning because he is always doing, always looking for new ways to do new things. Which is one way of saying there's no end of opportunity at Olin.)

Interesting people are on the job for Olin, all over the world. And they're doing interesting things.

Want to join them?

There's no hedge on this score; no gimmick, either.

In fact, all you have to do is get in touch with Mr. M. H. Jacoby (he's our College Relations Officer) at Olin, 460 Park Avenue, New York, N.Y. 10022. He'll answer any questions you might have, and if he can't answer them he'll send you to the fellow who can. And if you've got a healthy curiosity (and what graduate worth his salt hasn't?) you'll find that's just the beginning.

Start out talking to Mr. Jacoby and there's no telling where you'll wind up. (You may have shouldered a .22, but we'll give odds you've never wielded a machete.)

Olin

(An equal opportunity employer)

SPARTAN ENGINEER

VOLUME 18

NUMBER 2

JANUARY, 1965

FRED GEORGE editor

PHIL FRANK artist

Tom McLure

staff

JOE BOWMAN
ANDREW POOLE
RICHARD MURRAY
~~DEE GOSSETT~~
SUSAN GOODSSELL
BRIAN GOLUSKA
GARY ROMANS
~~MARIAN LOCKE~~

Dick Marrett

advisors

J. RYDER
C. MENSENDICK
T. FARRELL

G. Vandusen

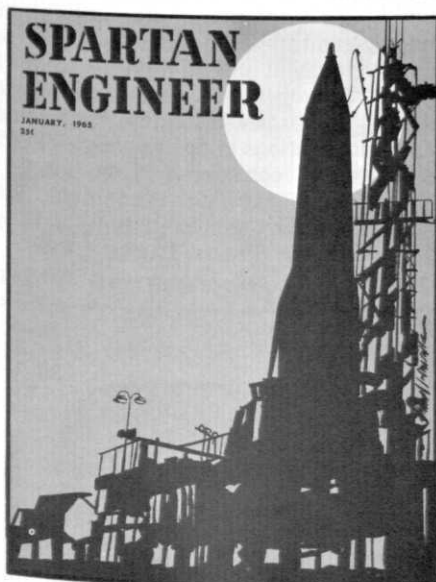

The Cover, drawn by Phil Frank, symbolizes the theme of one of the articles in this issue, that of water recovery in space.

FEATURES

A GUIDE TO EMPLOYMENT	18
WATER RECOVERY IN THE SPACE ENVIRONMENT	22
NEWS IN SCREWS	26
SPOTLIGHT ON INDUSTRY	34
HISTORY OF THE CALENDAR	46
A LETTER HOME	52

DEPARTMENTS

EDITORIAL	6
PLACEMENT BUREAU	10
INDUSTRIAL NEWS	40
BRAIN SPRAINERS	43
ENGINEERS	54
INDEX TO ADVERTISERS	55

SE

Member, Engineering College
Magazine Associated
Chairman: J. Gale Chumley

Louisiana Polytech Institute, Ruston, Louisiana
Publisher's Rep.: Littell-Murray-Barnhill, Inc.
369 Lexington Ave., New York 17, N.Y.
737 N. Michigan Ave., Chicago, Ill.

Published four times yearly by the students of
the COLLEGE OF ENGINEERING, MICHIGAN
STATE UNIVERSITY, East Lansing, Michigan 48823.
The office is on the first floor of the Engineering
Bldg., Phone 517 355-3520.
Subscription rate by mail \$1.00 per year. Single copies 25¢.

The small white rectangle above represents the approximate size of space required to contain one page of newspaper-size document reduced for storage through NCR's PHOTOCROMIC MICRO-IMAGE process. The small white dot on the right shows the area that would hold thousands of micro-capsules (cell-like structures containing useful materials) produced through NCR's amazing chemical process of MICRO-ENCAPSULATION.

One apparent application of the NCR Photochromic Micro-Image process is that it permits easy and efficient

storage, access and reproduction of voluminous data. The process of Micro-Encapsulation has applications cutting across many fields of interest including paper coatings (such as on our Carbonless Transfer paper), food, pharmaceuticals, adhesives, etc.

Our Research and Development programs are not limited to the fields of Photochromics and Micro-Encapsulation. Rather, the programs extend into many disciplines including physical and chemical research in the areas of semi-conductor materials and devices that will have practical

application in computer development and add to the total effort of the company. The NCR effort is concentrated on the total systems concept.

To determine whether your career plans fit in with our research and development plans, merely drop us a note with a brief description of your interests and scientific background. Applications at all professional levels will be considered. Write to: T. F. Wade, Technical Placement, The National Cash Register Company, Main & K Streets, Dayton 9, Ohio.

AN EQUAL OPPORTUNITY EMPLOYER

N

C

R

BE SURE TO VISIT THE NCR PAVILION AT THE NEW YORK WORLD'S FAIR

THE NATIONAL CASH REGISTER COMPANY ®

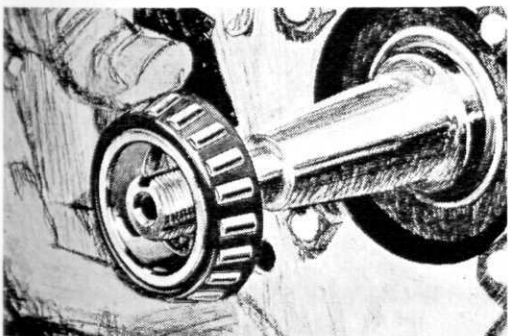
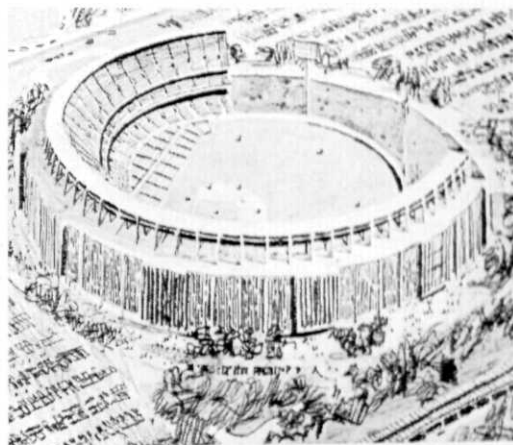
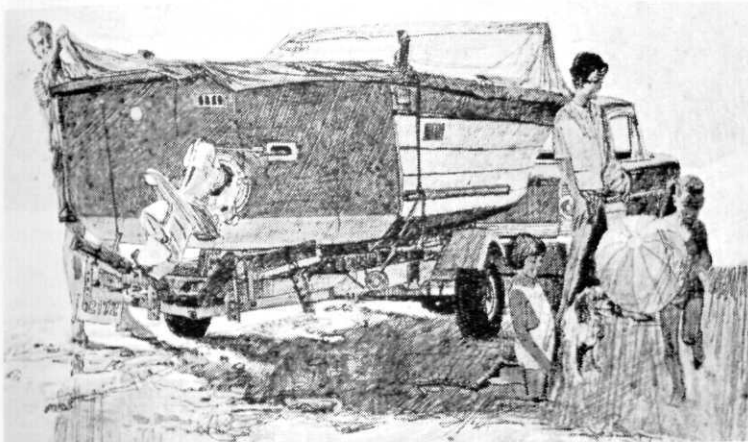

**You can
have a lot of
fun on Timken®
Bearings**

INBOARD WITH AN OUTDRIVE. This new Chrysler-Dana Drive 90° offers boating buffs big power in a small space. Dock your boat at home? The outdrive tilts up 55° for easy trailering. Timken® bearings keep the prop and drive shafts rigid as a Marine.

SEATS IN MOTION. New York's new Shea Stadium stands move to accommodate 10,000 fans in two blocks of 5,000 seats. They roll on Timken bearings from the first and third baseball foul lines to the football sidelines.

NO PLAY FOR BEARINGS. Timken bearings work hard to make your world more leisurely. They're made of nickel-rich steel for long life—even when loads and conditions become unsportsmanlike.

FORE? NO, THREE. Three wheels for the golfer who'd rather swing than walk. This new Cushman Golfster is a smart way to cover the links. Eight Timken bearings were chosen for the drive, axle and wheel applications. They're precision-made and case-hardened to take shock loads. The Timken Roller Bearing Company, Canton, Ohio. Also makers of Fine Alloy Steel and Rock Bits.



**QUALITY TURNS ON
TIMKEN®
TAPERED
ROLLER BEARINGS**

Learn More About the Timken Company, an Equal Opportunity Employer. Send for Career Booklet.

Faith of the Engineer

I AM AN ENGINEER. *In my profession I take deep pride, but without vainglory; to it I owe solemn obligations that I am eager to fulfill.*

As an Engineer, I will participate in none but honest enterprise. To him that has engaged my services, as employer or client, I will give the utmost of performance and fidelity.

When needed, my skill and knowledge shall be given without reservation for the public good. From special capacity springs the obligation to use it well in the service of humanity; and I accept the challenge that this implies.

Jealous of the high repute of my calling, I will strive to protect the interests and the good name of any engineer that I know to be deserving; but I will not shrink, should duty dictate, from disclosing the truth regarding anyone that, by unscrupulous act, has shown himself unworthy of the profession.

Since the Age of Stone, human progress has been conditioned by the genius of my professional forbears. By them have been rendered usable to mankind Nature's vast resources of material and energy. By them have been vitalized and turned to practical account the principles of science and the revelations of technology. Except for this heritage of accumulated experience, my efforts would be feeble. I dedicate myself to the dissemination of engineering knowledge, and, especially, to the instruction of younger members of my profession in all its arts and traditions.

To my fellows I pledge, in the same full measure I ask of them, integrity and fair dealing, tolerance and respect, and devotion to the standards and the dignity of our profession; with the consciousness, always, that our special expertness carries with it the obligation to serve humanity with complete sincerity.

Published by

Engineers Council for Professional Development



DEVELOPING NEW DESIGNS

Another of your future's many facets at Monsanto

With a company growing as fast as Monsanto (annual sales quadrupled to a hefty \$1.2 billion in little more than a decade), design of new plants, equipment and systems has never been so important. Engineers are needed to apply their skills and knowledge . . . in known and unknown areas . . . to help us manufacture the new and improved products that move Monsanto ahead—500 new products in the last 10 years.

We can show you what this means in terms of increased professional opportunity . . . how Monsanto's continuing expansion affords more and interesting growing room for you.

See your Placement Director to arrange for an interview when we visit your campus soon. Or write today for our brochure, "Your Future and Monsanto," to Manager, Professional Recruiting, Dept. CM 64, Monsanto, St. Louis, Missouri 63166.

An Equal Opportunity Employer



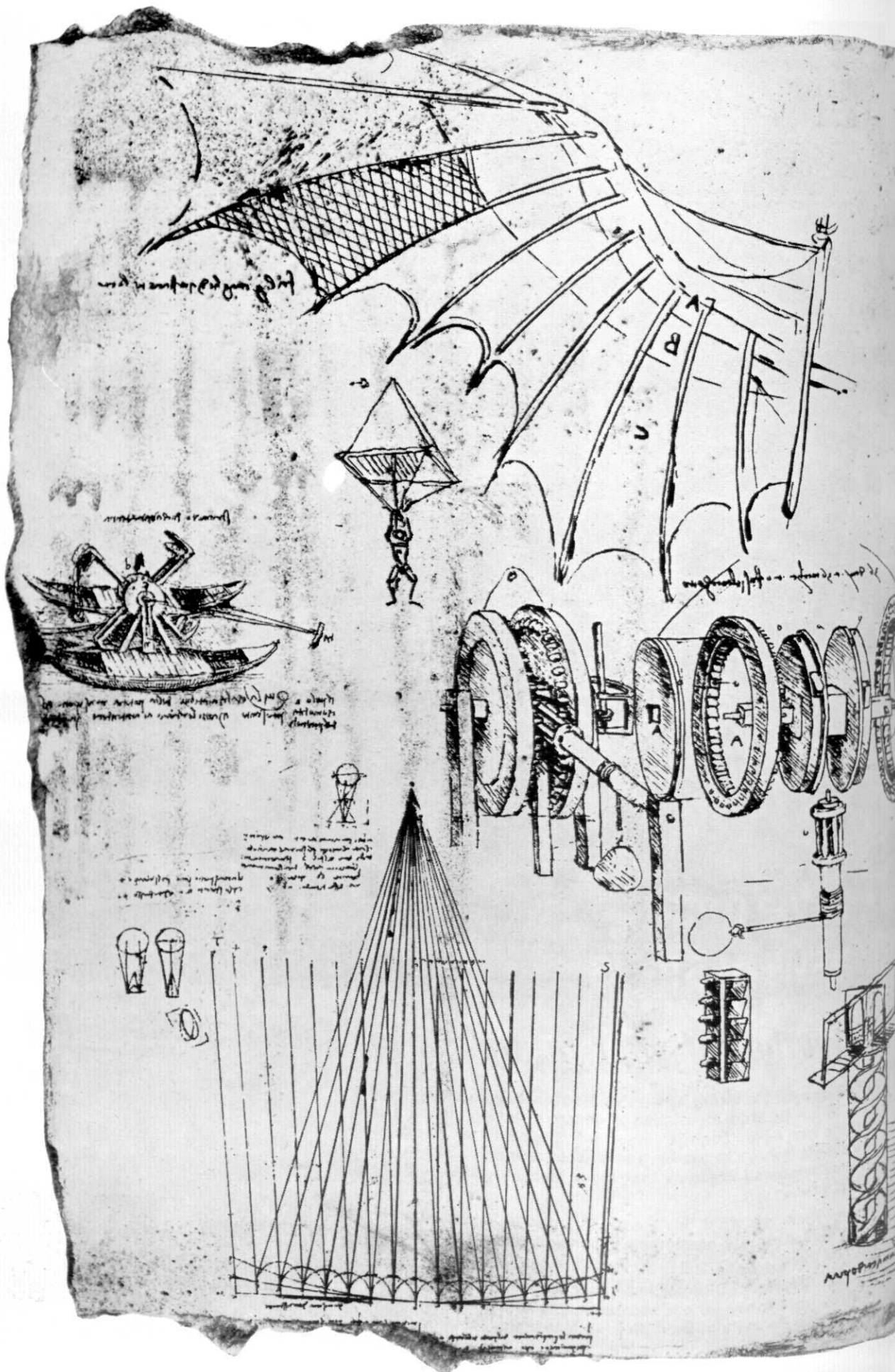

Handwritten text, possibly a title or label, located near the top winged structure.

Handwritten text located near the boat sketch.

Handwritten text located below the boat sketch.

Handwritten text located above the perspective grid drawing.

Handwritten text at the bottom right corner of the page.

**Leonardo
da Vinci
blazed
many new
trails...**

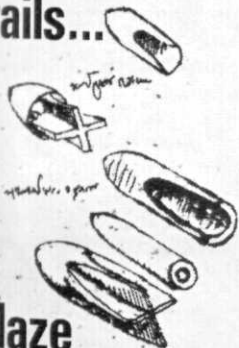

**Blaze
a few of
your own
at IBM**

Painting. Architecture. Engineering. Research. Leonardo da Vinci's genius was apparent in all these fields—and more. But variety of career interests and the tough problems that go with each are not restricted to the 15th century.

Today IBM seeks individuals with widely diverse interests to solve the many problems of designing, building and marketing computers. Our literature describes in detail the challenging careers open at IBM—and the various advanced education programs designed particularly for you.

See your college placement officer for information and an appointment with the IBM interviewers. Or write directly to Manager of College Relations, Dept. 915, **IBM** Corporate Headquarters, Armonk, N.Y. 10504. IBM is an Equal Opportunity Employer.

Applied Mathematics, Applied Mechanics,
Data-Communications, Digital Computers,
Guidance Systems, Human Factors,
Industrial Engineering, Information Retrieval,
Marketing, Manufacturing Research,
Microwaves, Optics, Programming,
Reliability Engineering,
Servomechanisms, Solid State Devices,
Systems Simulation and related areas.

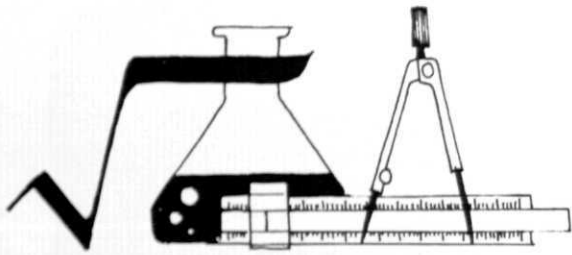

PLACEMENT BUREAU

January 25

North American Aviation

January 26

General Telephone and
Electric Laboratories
Ceco Steel Products Corp.
Swift & Co.
Department of the Navy

January 27

Union Carbide, Linde Company
Cooper Tire & Rubber
Owens-Illinois
Columbia Gas of Ohio
National Bureau of Standards
American Oil Company
Michigan Consolidated Gas
Cadillac Gage Company
DeSoto Chemical Coatings

January 28

W. R. Grace & Co.
Industrial Nucleonics
Allied Chemicals Corp.
American Cyanamid
Bureau of Public Roads, Lansing
Devoe & Raynolds

January 29

Eaton Manufacturing Co.

February 1

Minnesota Mining
Air Reduction Co.
Waterway Experiment Station
Economics Laboratory
Inland Container Corp.
Crown Zellerbach Corp.
Lear Siegler Inc.
American Air Filter
General Motors Corp.

February 2

Cummings Engine Co.
Control Data Corp.
Radio Corp. of America

February 3

American Oil Co.
General Electric
National Steel Corp.
Dow Chemical Corp.

February 4

Detroit Edison
Ford Motor Company of Canada
Anchor Hocking Glass

February 5

Square D Company
Jones & Laughlin

February 8

American Motors
Upjohn Company
McCord Corp.
Hercules Powder Co.
City of Detroit
The Budd Company
The Glidden Co.
Eli Lilly & Co.
General Electric
Lockheed Missiles & Space

February 9

Rockwell Standard Corp.
U. S. Steel Corp.
Shell Companies
Automatic Electric Co.
Corning Glass Works
Hewlett-Packard

February 10

Dow Corning Corp.
 General Foods
 Airborne Instruments
 Philco Corp.
 Sherwin-Williams
 Rex Chain Belt
 Amphenol Borg Electronics
 International Harvester
 Standard Oil

February 11

Inst. of Science & Technology
 All-Steel Equipment
 Diamond Alkali
 The Mead Corp.
 Nalco Chemical Co.
 Trane Co.
 Lockheed Aircraft

February 12

Midland-Ross Corp.
 Inland Steel Corp.

February 15

Fisher-Governor
 Standard Oil of Calif.
 Caterpillar Tractor
 General Dynamics

February 16

Alcoa

February 17

Chrysler Corp.
 Honeywell
 Olin
 Pittsburg Plate Glass
 Radiation Inc.
 Litton Systems

February 18

Babcock & Wilcox
 Walker Manufacturing
 Kaiser Aluminum
 International Milling Co.

February 19

Connell Aeronautical Labs.
 KVP Sutherland Paper Co.
 Motorola Inc.

February 22

U. S. Naval Civil Engineers
 Stanley Works
 U. S. Dept. of Commerce,
 Patent Office
 Ford Motor Co.
 General Mills Inc.
 National Castings

February 23

Brunswick Corp.
 Udylite Corp.
 Cleveland Electric Illuminating
 Martin Co.

February 24

Ford Motor Co.
 Chesapeake & Ohio Railway
 U. S. Rubber Co.
 Chevrolet - Flint Mfg.
 Texaco Co.
 Standard Oil Co.
 Sundstrand Corp.
 Bausch & Lomb Inc.

February 25

Youngstown Sheet & Tube Co.
 Allis - Chalmers Mfg.
 Magnavox
 Atlas Chemical Industries
 Owens Corning Fiberglas
 B. F. Goodrich Co.

February 26

California State Per. Board
 Parker-Hannifin
 Scott Paper Co.
 Aeronautical Systems Div.

March 1

Sperry - Phoenix Co.
 Continental Can Co.

CONTINUED ON PAGE 50 COLUMN 3



What's going on up there?

Ask us. Our space boosters have launched every successful non-military communications or weather satellite. Our *Saturn S-IVB* will power 3 *Apollo* astronauts from earth orbit to moon orbit. DC-8s have flown more than a billion miles. DC-9s will double the places you can go by jet. Which all adds up to the fact that Douglas can just about double your chances for rapid career advancement, because projects coming up are even bigger than those mentioned. Also, universities offering evening courses toward advanced degrees are close by. And Douglas has a fine scholarship program. Let's get together. We are an equal opportunity employer.

Douglas

Send your resume to
S. A. Amestoy, Box 694- K
Corporate Offices
Douglas Aircraft Co., Inc.
Santa Monica, California



We do research on oceanics,

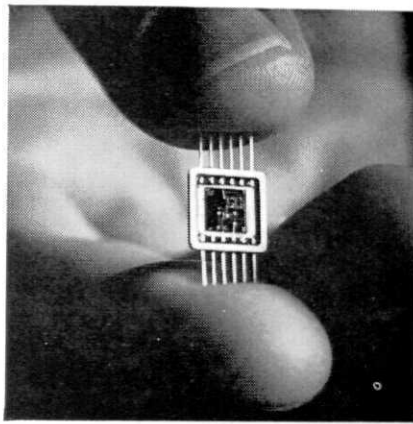

microcircuitry,

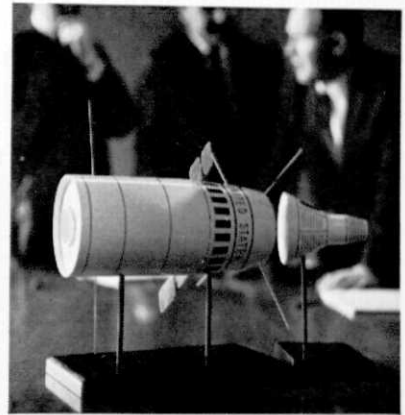

controls for space stations,



all-weather landing systems,

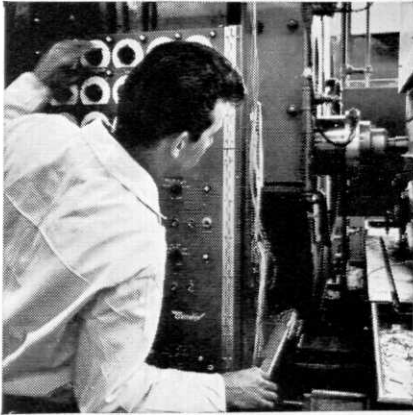

self-adaptive machines,

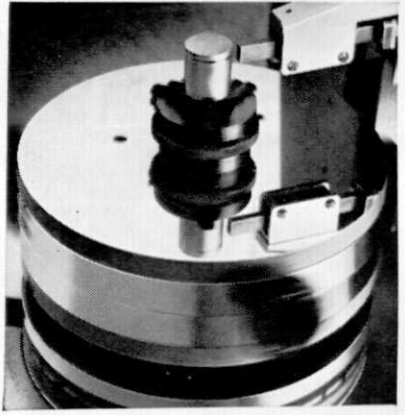

noncontact measuring gages,

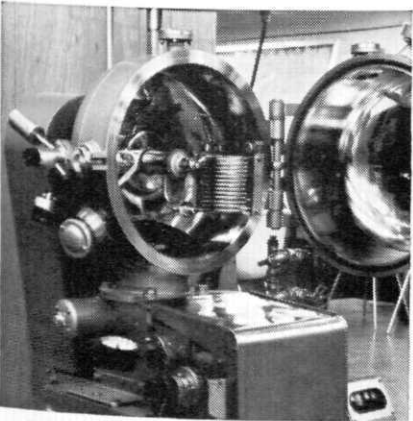

high vacuum equipment,



automotive brakes,



and lots of secret stuff.

What kind of company does it take to make significant contributions in all these fields? A company like Bendix with a proven record of research and production accomplishments in the space, missile, aviation, electronics, automotive, oceanics and automation fields.

If you enjoy the challenge of advanced engineering problems, examine our materials in your placement office,

and talk to our representative when he's on campus. For more information write Dr. A. C. Canfield, The Bendix Corporation, Fisher Building, Detroit, Michigan 48202.

Bendix operates 28 divisions and 8 subsidiaries in the United States, and 22 subsidiaries and affiliates in Canada and overseas.

THERE ARE BENDIX DIVISIONS IN: CALIFORNIA, MISSOURI, IOWA, OHIO, INDIANA, MICHIGAN, PENNSYLVANIA, NEW YORK, NEW JERSEY, MARYLAND.



An equal opportunity employer.

CREATIVE ENGINEERING FOR: SPACE □ MISSILES □ AVIATION □ AUTOMOTIVE □ OCEANICS □ AUTOMATION

This page is for

YOU

Letters sent to the Editor

containing comment,
suggestion, or

criticism, will be printed on this page.

Address letters to..

SPARTAN ENGINEER
144 Engineering Bldg.
East Lansing, Mich.

Defense Engineering at RCA

Current-Pumped Abrupt Junction Varactor Power-Frequency Converters

The varactor diode has become well known as an excellent device for low-noise amplification. Recently, however, the varactor diode has been used in high-level frequency converters as both a means of obtaining large amounts of power, tunable over wide bandwidths, and as a means of placing FM and PM information on a CW source, such as a varactor multiplier. The high-level parametric upconverter differs from a low-noise parametric amplifier in the area of conversion efficiency.

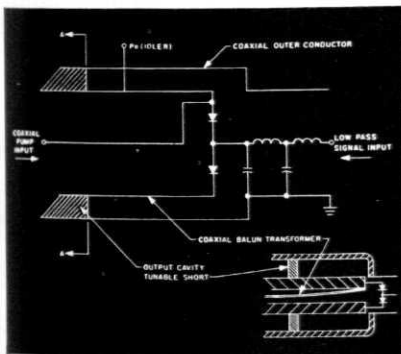

Coaxial-Balun Push-Pull Converter

One of the problems in the large signal solution for a varactor frequency converter is the infinite number of terms found when attempting to evaluate the Taylor expansion for charge as a function of voltage for an arbitrary varactor. If one reverses this approach, and finds the expansion for voltage as a function of charge, with a junction exponent, γ , of $\frac{1}{2}$ (abrupt junction varactor), it is found that the series is finite and easily utilized to find a more exact solution for the diode transfer impedance.

Because of its inherent symmetry, a push-pull application of the diodes provides a large degree of signal isolation, as well as an increase in allowable input power. This type of circuit provides an output at the upper sideband frequency which may be isolated from the pump circuit, by diode balance, without the need for lossy filters. Tunability is readily attained using the appropriate impedance matching networks without the added complications associated with low-loss tunable filters. A low-pass filter is necessary in the signal port to prevent the pump power from being dissipated in the signal circuit.

A simplified representation of a circuit using only coaxial networks, is shown in the figure. This particular circuit uses what might be referred to as a section of coaxial-coax. The diodes are pumped in series by means of a balanced transmission line, which may be designed using the techniques available for constructing "balun transformers." The signal

is introduced through a low-pass filter and drives the diodes in the push-pull, parallel mode. The resultant idler is generated in a TEM mode, with the conductors acting as a quarter-wave coaxial tuning assembly. The output may be removed using a current probe, coupled to the idler center conductor at the proper impedance tap. The output cavity may be tuned by varying the position of the rear shorting wall (A-A), using sliding finger contacts. With this approach, power levels of several watts have been handled with a conversion loss of 3db compared to power level of several milliwatts with 10db conversion loss for conventional resistive mixers.

Reference—Perlman, B. P., "Current-Pumped Abrupt Junction Varactor Power-Frequency Converters," to be published March 1965, *IEEE Transactions on Microwave Theory and Techniques*.

Room Temperature GaAs Laser Communications

Communications was among the first applications considered after the invention of the laser. Practical realization of the goal was delayed by the difficulties associated with inefficient energy conversion and inadequate modulation techniques. The discovery of the semiconductor injection laser in 1962 greatly reduced these difficulties, but introduced the restriction of operation under cryogenic conditions. Gallium arsenide injection lasers

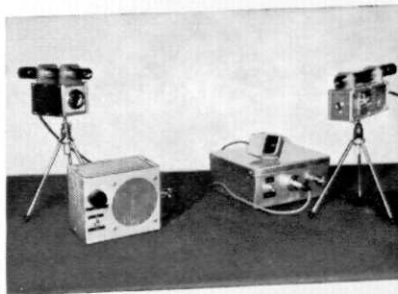

promise energy conversion efficiencies of 20-30%, while modulation of the optical signal can be accomplished simply by modulating the injection current. Early in 1964, the cryogenic restriction was eliminated when efforts of RCA scientists proved successful in discovering a type of gallium arsenide diode which exhibited laser action at room temperature with threshold currents much lower than those previously reported. This discovery permitted the engineering of a room temperature communications link and in May, 1964, such a communications link was demonstrated for the first time. The system employs pulse frequency modulation at a 20 kc repetition rate, has a bandwidth of 5 kc, and can operate in bright sunlight. Ranges up to three miles have been obtained while operating within the atmosphere. Using parallel diodes, a much greater range is feasible. The narrow linewidth of 20 angstroms permits the use of narrow band optical filters thereby reducing background noise. The system is free of radio frequency

interference which plagues conventional communication systems, and is so efficient that three nickel cadmium batteries (the size of standard flashlight cells) can provide hours of continuous operation.

Reference—#1. H. Nelson, J. I. Pankove, F. Hawrylo, G. C. Dousmanis, C. W. Reno, "High-Efficiency Injection Laser at Room Temperature," *Proc. IEEE (correspondence)*, Vol. 52, No. 11, p. 1360, Nov., 1964. #2. D. Karlsons, C. W. Reno, W. J. Hannan, "Room Temperature GaAs Laser Voice Communication System," *Proc. IEEE (correspondence)*, Vol. 52, No. 11, p. 1354, Nov., 1964.

15 Megacycle Tape Bandwidth Response

RCA engineers have developed an advanced magnetic recording system with the highest bandwidth response reported to date. This achievement results from integrated efforts in all phases of magnetic recording, such as: air bearing design, high performance servos (50 kc response), precision mechanisms and magnetic head circuitry.

This recent accomplishment is being used in equipment with two 8 Mc bandwidth channels designed for application in a precision radar system. In this design the heads are rotated to achieve 3200 inch-per-second head-to-tape speed in a transverse scan mode. The unit uses a specialized form of a frequency modulated carrier system to achieve a response from 100 cycles per second to 8 Mc. The 3200 IPS head speed permits a wavelength of 0.32 mils at a 10 Mc FM carrier. Head gap lengths of 90×10^{-6} inches are employed to achieve FM response to 15 Mc.

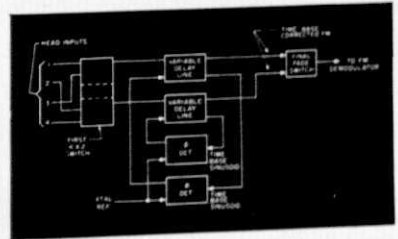

Closed-loop electronically variable delay line system

In order to effect a high reproduction accuracy for radar use, five servomechanisms are employed to insure stability of tape and head motion. The most interesting of these is a pure electronic servo employing the principle of variable delay to remove time displacement errors from the signal. This system employs a 25 to 1 loop gain at a bandwidth of 50 kc. This closed-loop system achieves a time-base accuracy of ± 10 nanoseconds. The rms value of this error is less than 5 feet of radar range error, a new standard of excellence for radar recording accuracy.

Reference—F. D. Kell and J. D. Rittenhouse, "Advanced Tape Equipment for Instrumentation Recording," *RCA Publ. No. PE-189*, containing reprints of 13 technical papers on Magnetic Recording.

These recent achievements in Defense Engineering are indicative of the great range of activities in research, applied research, advanced development, design and development at RCA. To learn more about the many scientific challenges in both defense and commercial engineering awaiting bachelor and advanced degree candidates in Electrical or Mechanical Engineering, Physics, Chemistry or Mathematics, write: College Relations, Radio Corporation of America, Cherry Hill, New Jersey.



The Most Trusted Name
in Electronics

An Equal Opportunity Employer

Why become an engineer at Garrett-AiResearch? You'll have to work harder and use more of your knowledge than engineers at most other companies.

If you're our kind of engineer, you have some very definite ideas about your career.

For example:

You've worked hard to get a good education. Now you want to put it to work in the best way possible.

You will never be satisfied with run-of-the-mill assignments. You demand exciting, challenging projects.

You not only accept individual responsibility — you insist upon it.

Does that sound like you? Then AiResearch is your cup of tea.

Our business is mainly in sophisticated aerospace systems and subsystems.

Here, research, design, and development lead to production of

actual hardware. That means you have the opportunity to start with a customer's problem and see it through to a system that will get the job done.

The product lines at AiResearch, Los Angeles Division, are environmental systems, flight information and controls systems, heat transfer systems, secondary power generator systems for missiles and space, electrical systems, and specialized industrial systems.

In the Phoenix Division there are gas turbines for propulsion and secondary power, valves and control systems, air turbine starters and motors, solar and nuclear power systems.

In each category AiResearch employs three kinds of engineers.

Preliminary design engineers do the analytical and theoretical work, then write proposals.

Design engineers do the layouts; turn an idea into a product.

Developmental engineers are responsible for making hardware out of concepts.

Whichever field fits you best, we can guarantee you this: you can go as far and fast as your talents



can carry you. You can make as much money as any engineer in a comparable spot — *anywhere*. And of course, at AiResearch, you'll get all the plus benefits a top company offers.

Our engineering staff is smaller than comparable companies. This spells opportunity. It gives a man who wants to make a mark plenty of elbow room to expand. And while he's doing it he's working with, and learning from, some of the real pros in the field.

If the AiResearch story sounds like opportunity speaking to you — don't fail to contact AiResearch, Los Angeles, or Phoenix, or see our representative when he comes to your campus.

An equal opportunity employer

AiResearch is challenge



Los Angeles • Phoenix



You never stop growing at Du Pont

Growth is a 160-year habit with us. Take sales. Since 1937 they've increased 750%—to \$2.4 billion in 1962.

We spend more than \$90 million a year in R&D. In fact, there are at least 200 new products under investigation at this writing and more being developed each day.

What could Du Pont's growth mean to you? Since we always fill important positions from within, it could mean fast advancement, new responsibilities, new horizons—growing financial and creative satisfaction.

It could mean, too, more numerous and more varied opportunities. The new Du Pont engineer is likely to move from his original assignment to one or two others in the course of his first five years. This gives him a chance to "change jobs" right inside Du Pont.

In 1963, more than 700 new B.S. graduates planted their feet at Du Pont. Perhaps you'd like to join us, too. Write today.



BETTER THINGS FOR BETTER LIVING . . . THROUGH CHEMISTRY

An equal opportunity employer

TECHNICAL MEN WE'LL NEED FROM THE CLASS OF '65

Chemists

Mechanical Engineers

Chemical Engineers

Industrial Engineers

E. I. du Pont de Nemours & Co. (Inc.)
2531-B Nemours Building
Wilmington, Delaware 19898

When I'm graduated, I'll be a _____
(List profession)

Please send me more information about how I might fit in at Du Pont.

Name _____

Class _____ Major _____ Degree expected _____

College _____

My address _____

City _____ Zone _____ State _____

GUIDE TO EMPLOYMENT

by Sue Goodsell

16 1/2

Sooner or later, nearly all of us will be leaving school to find our places in the employment world. This change may be facilitated by the intelligent use of an important university service, the Placement Bureau.

The MSU Placement Bureau is often considered the best in the nation, providing opportunities for undergraduate and graduate students in both permanent and temporary employment. A staff of six qualified men provide vocational information to students upon request. There is also a brochure library with material on over two thousand employers having pertinent opportunities for MSU students.

What is the objective of an organization of this nature? In the words of Bureau director Jack Shingleton, "The purpose of the Placement Bureau is to assist students in their effort to get employment upon graduation. We feel that after a student has spent at least sixteen years in acquiring an education he should get the best possible employment for his qualifications. This is in the best interest of the student, the faculty, the university, and the nation."

The importance of finding the right job for a student cannot be overemphasized. Mr. Shingleton continues, "Choosing a career is one of the most important decisions a student can make. We make an effort to provide him with all the options to make a good and sound decision. Because of the services offered by the Placement Bureau, Michigan State students have a far greater range of opportunities than they would otherwise.

"It is important that a student get not only a job upon graduation, but that he get the best job available to him. Too many students settle on the first job that 'comes down the pike,' and do not end up with the job that best suits their interests and qualifications."

A typically MSU quality of the Placement Bureau is its size. During the 1963-64 academic year, a total of 13,113 job interviews, with representatives from 1,342 different employers, were held through Bureau facilities. Engineering students accounted for 2,524 of the total.

How does one go about utilizing this service, and finding that "best job"? A student should ex-

amine the company brochures and procedures to decide upon those which most interest him. After this preliminary choosing, he should regularly check the weekly Placement Bureau Bulletin, or "yellow sheet," to see when the representative to the chosen organization will be on the campus. The next step, logically enough, is to sign up for an interview at a convenient time, two days to a week in advance.

Then, the Bureau library becomes a reference to give the student the basic facts about the organization and to enable an intelligent exchange with the interviewer. Preparation (or lack of it) for an interview will undoubtedly have an effect on the outcome.

What are the steps following the interview? Generally, a student who has favorably impressed his interviewer will be invited to acquaint himself more fully with the organization through a visit to the company. Needless to say, this is a two-way acquaintance process. Following this may come an offer of employment with the firm.

CONTINUED TO PAGE 20



The MSU Placement Bureau





Jack Shingleton, Director of the Placement Bureau gives advice to an interviewee.

CONTINUED FROM PAGE 18

The twenty-minute interview at the MSU Placement Bureau may well determine the course of a student's working life; it is not to be lightly considered.

Engineering students will find a surplus of opportunity in their fields. As an example, there were more than 456 specific company requests for graduating mechanical engineers during the 1963-64 academic year. Prospects in the other departments are also very favorable.

Average starting salaries for BS holders were over \$600 per month, with Electrical Engineers leading the group at \$633. Those with Master's degrees averaged \$100-150 higher.

In addition to permanent positions, summer employment in a student's field is handled through the office of Mr. Thomas Rand. The aim is to provide meaningful temporary employment giving the student a good

look at the company and an idea of what it is like to work in such an organization or industry. The summer employment service is essentially a beginning; after an application is submitted, the student corresponds directly with the firm.

Last year, nearly five thousand students were interviewed for summer positions. The College of Engineering had representatives in all types of work. Returning recruiters brought favorable comments on their summer assistants, as did the majority of the returning students.

Engineering students in their junior and senior years of study who plan to return to school may be assisted in finding positions which utilize their knowledge through Mr. Rand's office. Applications submitted through the various departments to Mr. Rand's office will enable students to be considered only for those positions of interest to them, and

for which they are qualified.

Part-time employment services during the academic year are open to all students. Positions made available through the Bureau are reserved for MSU students, but may be either on-campus or off-campus opportunities.

MSU alumni who wish to change their employment are eligible for Placement Bureau assistance. Last year approximately a thousand alumni were aided in making job changes.

An often-helpful publication, The College Placement Annual, is available for use by students, and is distributed by the Placement Bureau free of charge.

Michigan State offers its students excellent opportunities for locating the employment they desire. The student who understands and makes good use of the Placement Bureau is at a distinct advantage in his attempt to select a meaningful, satisfying, and worthwhile career.

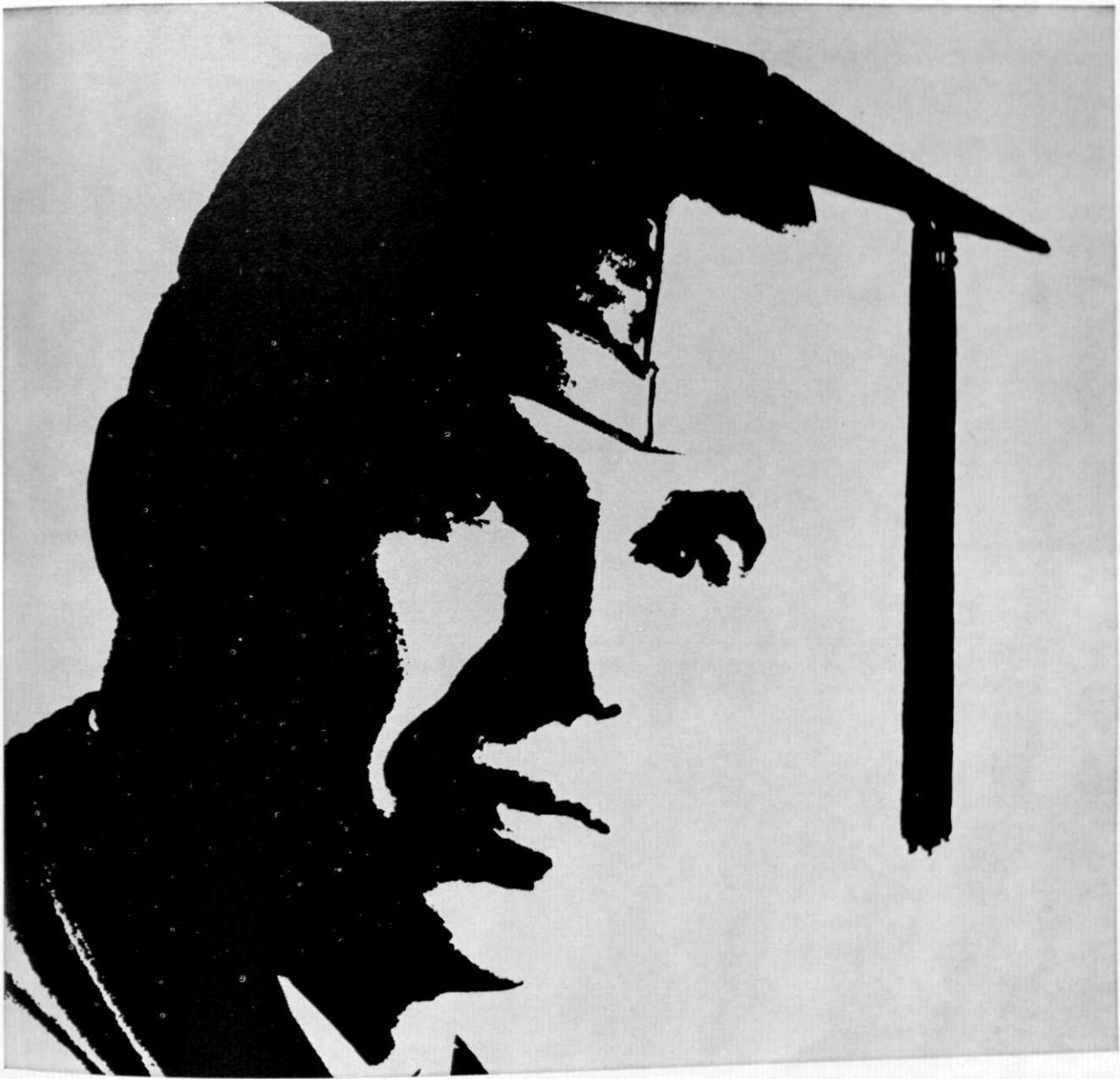

What every graduating engineer (and his professors) should know about AC-MILWAUKEE

Sure, everybody's got a career program. But we think you'll find ours a little more stimulating, more rewarding, and at least intriguing enough to spend the next minute or so reading about it.

We call it our "Career Acceleration Program." In it, you'll work on such advanced projects as an avionics system for supersonic aircraft, a guidance/navigation system for the Apollo Command Module and LEM, and a new guidance system for the Titan III space launch vehicle.

Seven hours a day you'll work on a specific project. You'll spend one hour each day in formal class work. These classes include courses in Inertial Instruments, Inertial Guidance, Digital Computers, Advanced Transistors, Advanced Servomechanisms, Integrated Circuits, Space Mechanics, plus other mathematics and undergraduate disciplines as required.

We also have a Tuition Refund Plan that pays all of your tuition costs upon satisfactorily completing college-level courses of study undertaken voluntarily. Our "in-plant" evening educational program offers additional opportunities for technical improvement.

If you are completing your BS or MS degree in EE, ME, Math or

Physics, we invite you to inquire about the opportunities at any of our three locations. AC in MILWAUKEE—our main research, development and manufacturing facility. AC in BOSTON—our Research and Development Laboratory specializing in advanced inertial components; spacecraft and avionics guidance/navigation systems. AC in LOS ANGELES—our Research and Development Laboratory specializing in advanced airborne computers; ballistic missile and space booster guidance/navigation systems. For further information, see your college placement office regarding a General Motors/AC on-campus interview, or write directly to Mr. G. F. Raasch, Director of Scientific and Professional Employment, Dept. #5753, General Motors Corporation, Milwaukee, Wisconsin 53201. PhDs, please note: Positions are available in all three AC locations for PhDs, depending on concentration of study and area of interest. You are invited to contact Mr. Raasch for additional information.

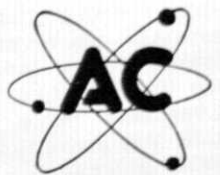

AC SPARK PLUG
The Electronics Division
of General Motors
An Equal Opportunity Employer

Water Recovery In The Space Environment

by Richard L. McCandless

EDITOR'S NOTE: This is part two of a paper prepared as part of the program of an Engineering Undergraduate Research Assistantship during 1963-64, and supervised by Carl W. Hall, Department of Agricultural Engineering. Part one was printed in the November issue.

FREEZING

Several processes involving freezing hold promise for water purification in space. The simplest is that of freeze crystallization, in which, either by conventional refrigeration or by "flashing off" some of the water present as vapor, impure liquid is cooled until small ice crystals form. The crystals are filtered out, washed and melted; they are most easily removed if they are made to form on a refrigeration coil inserted in the liquid. Freeze crystallization has been used on a large scale on sea water. It is an attractive process for space because it is easily performed without gravity and all the required cold is freely obtained from space. It has one major disadvantage: once the crystal has formed, ionic impurities are incorporated on its surface as it grows. Therefore, there is an optimum crystal size, and crystals which are screened out must be thoroughly washed with pure water before being melted. Freeze crystallization products probably could be made more pure by continuous counter-current washing of the ice particles while forming. If this is done, crystals can be seeded and allowed to grow larger, facilitating their removal and handling. Especially on a larger scale, this may prove to be a very valuable process.

A second process using freezing for the removal of impurities

from liquids is that of reiterative freezing. In 1962, scientists of the Minneapolis - Honeywell Regulator Company experimented with several such techniques. The simplest was that of filling a cylinder with liquid to be purified and slowly immersing the cylinder in a freezing bath, while a stirrer agitated the liquid-solid interface. Impurities slowly moved to the last section frozen; this part was discarded and the rest of the frozen block was melted and retreated.

Fifteen such repetitions produced a 70% yield of drinkable water. A reiterative freeze purification process may be more effective under zero-gravity conditions than the separation of

liquids from gases used in distillation processes. The Minneapolis-Honeywell researchers found that the process did not remove bacteria, however, and further filtration, exposure to ultra-violet radiation, or sterilization was necessary before the water produced was potable.¹⁸

Some work has been done on the use of sublimation to purify urine. The urine is first frozen and the ice is sublimed under very low pressure, resulting in the removal of only water as vapor. Because of the low pressure and temperature requirements (water will not sublime above 20 degrees F), this process requires

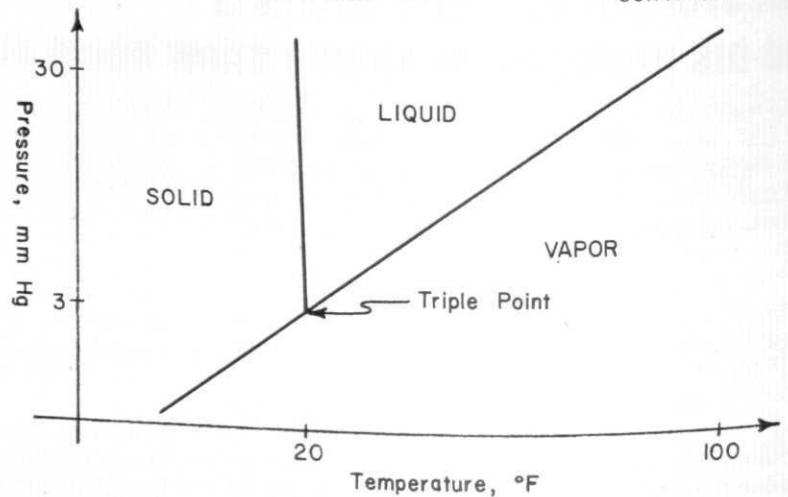

CONTINUED ON PAGE 24

Figure 4: PHASE DIAGRAM OF URINE (HENDEL)



Don't miss the boat!

The boat is the Navy's Hydroskimmer, powered by four 1100-horsepower gas turbines built by the Solar Division of International Harvester.

More significantly, the skimmer is a symbol of new opportunities at IH—the company that is also developing gas turbine power for tractors and trucks—the company that is already number one in heavy-duty trucks, farm tractors and equipment—that is building new plants on six continents to serve customers in 144 countries of the free world.

We are also growing in construction equipment and steel production. Research and engineering expenditures are becoming one of our largest budget items.

We need mechanical, electrical, chemical, metallurgical, agricultural, ceramic and general engineers. Check your Placement Office now for a date to see an IH representative when he visits your campus. If interviews are not scheduled, write directly to the Supervisor of College Relations, International Harvester Company, 180 N. Michigan Ave., Chicago 1, Ill.

INTERNATIONAL HARVESTER

An Equal Opportunity Employer

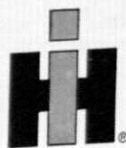

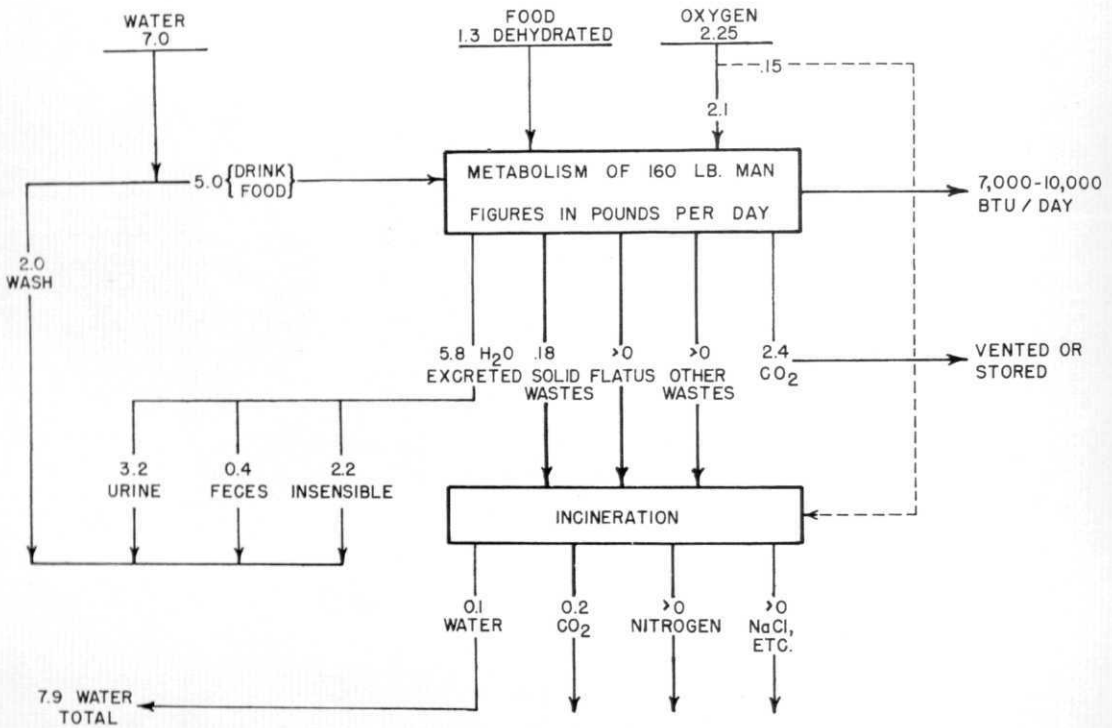

Figure 5: HUMAN MATERIALS TURNOVER. SYSTEM INCLUDES PARTIAL INCINERATION OF WASTES (HENDEL)

CONTINUED FROM PAGE 22

bulky equipment and large space radiators to reject the heat of condensation into space. About 16 sq. ft. of space radiator per man-day of operation must be built into such a system. J. Sendroy and H. A. Collison performed trials of a freeze-sublimation process on urine, alternately pre-treating the urine with activated carbon, post-treating it with carbon, and not treating it at all. The liquid recovered had a faint taste and odor which was eliminated by passage through activated charcoal, but otherwise was pure. When feces were added to the urine, the sublimed water had a strong odor.¹⁹

Freezing processes may come into greater use as time progresses. The power required to reduce the temperature of urine from 60 degrees F to 32 degrees F where it freezes, is considerably less than the power required to raise its temperatures from 60 degrees F to the boiling point (the former is 400 kwh/1,000 gals., the latter, about 2,740 kwh/1,000 gals.). As water is frozen out of the urine, of course, the concentration of ions increases and the temperature must be con-

tinuously lowered. As freeze purification systems are developed further, they will probably be comparable in weight to osmotic systems and somewhat superior in power requirements to both osmotic and distillation systems.²⁰

INCINERATION

A totally different system for the purification of usable products from human wastes of all sorts has been presented by Frank J. Hendel (Figure 5). In this process, all human wastes are blended into a sludge by an agitator. The sludge and oxygen or compressed air are slowly fed by a worm screw to an electric heater, where the wastes are burned at about 850 degrees C. Water is evaporated and all organic wastes are oxidized or vaporized. The hot vapors are then forced over a catalyst to insure complete conversion to water, carbon dioxide, and nitrogen. When the vapors are cooled, water condenses and is transferred to a storage tank, and nitrogen and carbon dioxide are vented. Solid residues, mainly

sodium chloride, collect in the "hot zone" around the heater and must be removed occasionally. This may be done by blowing air back against the normal flow of vapors through the heating chamber and catalyst tubes, collecting salt dust in a filter bag at one end of the chamber. Control of temperature in the burner zone is critical to assure that ammonia is oxidized to nitrogen gas and not to nitrogen monoxide.

The reaction
 $4\text{NH}_3 + 3\text{O}_2 = 2\text{N}_2(\text{g}) + 6\text{H}_2\text{O}(\text{g})$
 + 300,600 calories
 is favored at a lower temperature, while
 $4\text{NH}_3 + 5\text{O}_2 = 4\text{NO}(\text{g}) + 6\text{H}_2\text{O}(\text{g})$
 + 214,200 calories
 is favored at a higher temperature. Ammonia comes from the heating of urea with water:
 $\text{CO}(\text{NH}_2)_2 + \text{H}_2\text{O} \rightleftharpoons \text{CO}_2(\text{g}) + 2\text{NH}_3(\text{g})$
 Some is produced from the heating of a dry urine residue:
 $2\text{CO}(\text{NH}_2)_2 \rightleftharpoons \text{NH}_3(\text{g}) + \text{NH}(\text{CO}(\text{NH}_2)_2(\text{biuret}))$

In this system, control of pH is essential; it is accomplished by a pH probe in the water output

CONTINUED ON PAGE 30



And a lot of imagination! Think working with a "one material" company would be pretty dull? Consider this... starting with sand, Corning's scientists and engineers have created more than 100,000 different glass formulas... more than 43,000 specialty glass products.

They've developed micro-miniature electronic components, glass-ceramics for missile nose cones, glass so strong it can be bent and twisted, glass that darkens on exposure to light, glass so rare it costs \$500,000 a pound.

Innovation is Corning's hallmark. 65% of our business is in products not available 15 years ago. Innovation, too, is the reason we've grown 81% in the past five years ('63 sales—more than \$289 million). And the reason we'll continue to grow. Almost six cents of every sales dollar goes to research. Check other leading companies.

Emphasis on R&D presents a constantly changing challenge for our engineers. For you, it could also mean early responsibility, rapid advancement, the satisfaction that comes with discovering unique answers to unusual problems.

Find out more about a career with Corning. We have challenging opportunities available for every type of technical graduate. Mark and mail our coupon today.

Mr. Frederic C. Hood
Corning Glass Works
Corning, New York 14832

Please send me more information about career opportunities with Corning.

Name _____

Class _____ Major _____ Degree Expected _____

College _____

My Address _____

City _____ State _____ Zip Code _____

CORNING
CORNING GLASS WORKS

An equal opportunity employer

NEWS IN SCREWS

Information and photos by
Dumont Industrial Screw Corp.

Yankee ingenuity is still doing it! The same society that produced the epitaxial silicon transistor, the laser, and the self-driving screwdriver, has now come up with some modern fasteners to keep pace with the technical advances on all fronts.



Combination Thread (Right and Left Hand)

This new development is a boon to production. Now with this New Combination Thread, one can insert or remove the screw by turning the screw either right or left. No time is lost in stopping to think.



Threadless Wood Screws

These new Threadless Wood Screws serve the same function as other old type wood screws. However, these new type wood screws do not require a fancy screwdriver to drive them. Any old hammer, rock, or brick will do the job.

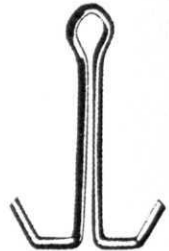

Pre-Bent Cotter Pins

Bending cotter pins into the proper shape is a job which requires some dexterity and skill, and is time consuming. Installation of these new advanced Pre-Bent Cotter Pins can be done by any unskilled person in practically no time at all. This saves considerable time.

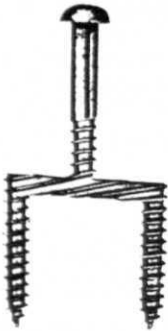

New Joining Screw

This New Joining Screw takes the place of two ordinary screws. This screw is particularly useful on butt joints and miter joints. When this screw is used 50% of time and labor will be saved.

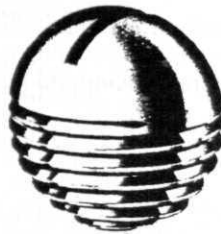

Screwballs

A new first in the industry of fasteners. Every project or machine is not complete without at least one Screwball. Screwballs are available in assorted sizes and with different surface finishes. Some are coated with chrome and/or zinc and some are just plain screwballs.



Knothole Wood Screw

The special Knothole Wood Screw was developed for use with knotty wood. With this special screw one does not have to drill special pilot holes or make other special arrangements. This screw reduces failures and rejects.



Cork Screws

The public has for a long time demanded large quantities of Cork Screws. For years the fastener industry has had to supply Cork Screws made of steel. Now Cork Screws are available which are made of genuine cork.



Countersunk Lock Washers

These Countersunk Lock Washers come in 1" outside dimension only. The inside dimension is available in any size. These special purpose washers come in assorted colors and are equipped with a special cork compression pad.



High Speed Bolts

This new line of High Speed Bolts requires only half the time to fasten because there are only half the usual number of threads. This means that you can use twice as many bolts per unit area with no increase in labor costs.



Self-Countersinking Wood Screws

This new development in wood screws eliminates any countersinking operations. The threads on the head force the screw down into the surface just as far as you want to go, even farther.



Right-Angle Screw for Hard-to-get-at Places

The problem of avoiding objects such as other screws or nails has been solved with the use of this new Right-Angle-Screw for Hard-to-get-at Places. Also available is a Left-Angle Screw for Hard to get at Places.



Square Deal Screws

These new Square Deal Screws are designed especially for use with square holes. The wisdom of using round pegs for round holes is apparent. However, up to this point there has been no solution to the problem of square holes.

Providing power for every environment . . .

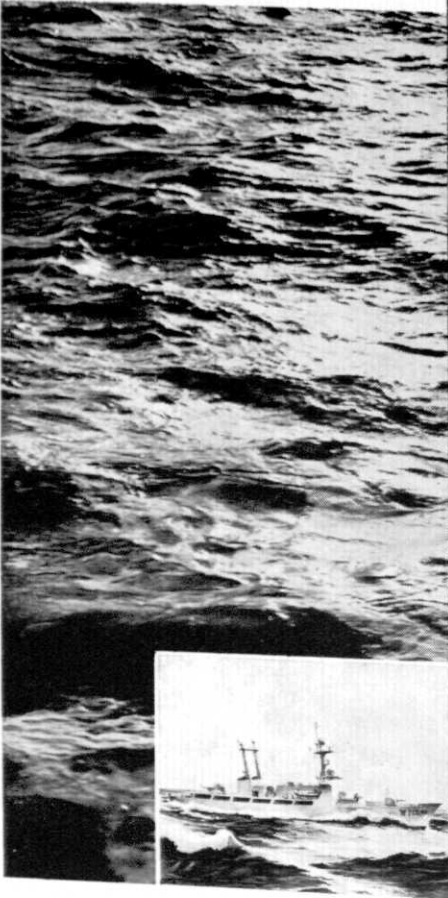

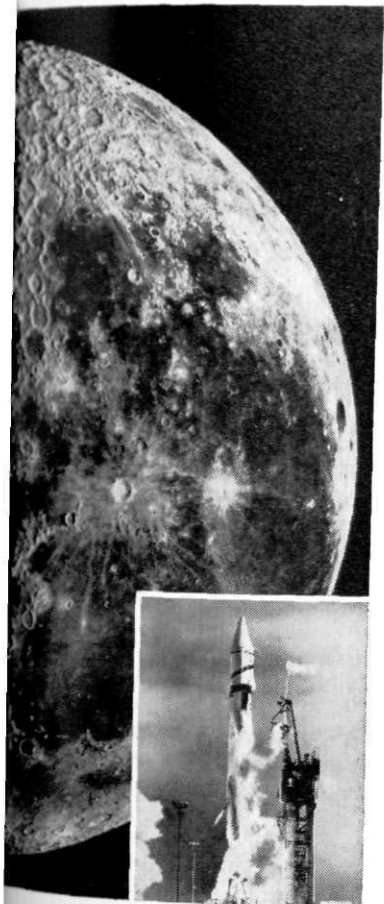

**provides
challenge
for
virtually
every
technical
talent
at
Pratt & Whitney
Aircraft**

Being a technically trained man . . . we assume you are looking ahead to a career of exciting growth and accomplishment and that you are looking for a company possessing these same qualities.

If our assumption is correct, we would like you to take a close look at us. For this Company, while solving the problems of the day, thrives on a sort of creative restlessness which anticipates the challenges of tomorrow. And more important to you, it recognizes its engineers and scientists as the master key to its present success and future progress.

From a solid foundation of basic and applied research, our Company has gained a firm foothold in the land, sea, air, and space programs that are helping to shape our nation's future. Our engineers and scientists are exploring ever-broadening avenues of *energy conversion for every environment*. Should you join them, you'll be assigned early responsibility . . . to apply your engineering talents to such areas as advanced gas turbines . . . rocket engines . . . fuel cells and nuclear power.

Such trail-blazing projects command the best of varied talent. That's why you'll find at Pratt & Whitney Aircraft men with college training as diverse as their responsibilities. You will also find that opportunities for professional growth are further enhanced by our corporation-financed Graduate Education Program. Your degree? It can be a B.S., M.S. or Ph.D. in: **MECHANICAL • AERONAUTICAL • ELECTRICAL • CHEMICAL and NUCLEAR ENGINEERING • PHYSICS • CHEMISTRY • METALLURGY • CERAMICS • MATHEMATICS • ENGINEERING SCIENCE or APPLIED MECHANICS.**

For further information concerning a career with Pratt & Whitney Aircraft, consult your college placement officer—or—write to Mr. William L. Stoner, Engineering Department, Pratt & Whitney Aircraft, East Hartford 8, Connecticut.

SPECIALISTS IN POWER . . . POWER FOR PROPULSION—POWER FOR AUXILIARY SYSTEMS. CURRENT UTILIZATIONS INCLUDE AIRCRAFT, MISSILES, SPACE VEHICLES, MARINE AND INDUSTRIAL APPLICATIONS.



Pratt & Whitney Aircraft

CONNECTICUT OPERATIONS EAST HARTFORD, CONNECTICUT
FLORIDA OPERATIONS WEST PALM BEACH, FLORIDA

**U
A**
DIVISION OF UNITED AIRCRAFT CORP.
An Equal Opportunity Employer

tube, which controls the burner temperature. Mr. Hendel feels that the incineration of all wastes should be more efficient than any system previously proposed and would avoid a storage or disposal problem. He foresees negligible power requirements for the system if good heat exchangers and insulation are used. The exothermic oxidation of organic materials and ammonia helps to decrease power requirements.²¹

FUEL CELLS

Fuel cells have received considerable attention as possible sources of both power and pure water in space. A simple cell consists of two electrodes separated by an electrolyte. A fuel such as hydrogen is passed over the anode, where electrons are generated which flow through the external circuit to the cathode and are consumed by an oxidizing agent, e.g., oxygen. Ionic conduction through the electrolyte complete the circuit. Fuel cells are available using many different kinds of fuel of four general types: hydrocarbons, including methane; non-hydrocarbons (hydrogen, ammonia, hydrazine, and sodium - amalgam); reformed fuels (CH₃OH and other hydrocarbons); and specialty fuels (regenerative fuels, liquid metals, etc.).

The simplest and most highly developed fuel cell is the hydrogen-oxygen cell, and proposed space applications of fuel cells generally refer to these cells. The reactions in these cells produce water at the rate of about 1 pound per kilowatt-hour--a one kilowatt cell could provide one pound of water per hour of use. The removal of this water has been a major problem in fuel cell design. Of the several manufacturers who have built cells, General Electric uses a wicking system to remove water, Pratt and Whitney uses a circulating electrolyte which requires an extra pump, and Allis - Chalmers, a "Static Moisture Removal System" using a membrane near the cathode to exhaust water to a vacuum. Fuel cell reliability has been a very important factor. Operation of the cell at a lower current density but higher voltage

yields the best fuel economy, allows better control, and minimizes heat and moisture removal problems. It should be possible to repair the fuel cell in space. This favors a more convenient and accessible low temperature-low pressure system.

Allis-Chalmers has produced a 50-watt fuel cell unit for the Air Force and NASA. The unit, applicable to almost any space mission, is slated to fly sometime this year; it is rated at 30 watts per pound and 3.0 kw per cubic foot. If auxiliary equipment is included, these figures are lowered to 18 watts per pound and 1.1 kw per cubic foot. Allis-Chalmers has also produced a working one kilowatt system.

Pratt and Whitney's hydrogen-oxygen fuel cell uses an electrolyte which is 85% potassium hydroxide, and avoids high pressure operation. However, since potassium hydroxide is a solid at room temperature, special loading techniques are used and the cell must be brought to 200 degrees C. before useful power can be obtained. Nickel electrodes are used to retain the electrolyte.

NASA has decided to concentrate on fuel cells for auxiliary power in the Apollo, Gemini, and LEM projects. General Electric and Pratt and Whitney have delivered models of their auxiliary power systems for the Gemini and Apollo projects, respectively, to NASA. Pratt and Whitney is also involved in the LEM project.

Indirect biochemical fuel cells using biochemical catalysts (enzymes and microorganisms) to generate conventional fuels are being studied and direct bio-

chemical cells in which the organisms are themselves part of the electrolytes have also been given consideration. The electrical potentials of such cells are associated with the equilibria of metabolic processes.²²

CLOSED SYSTEMS

Environmental control systems for use on the moon and beyond are now envisioned as closed systems using photosynthetic gas exchangers in which algae in a water suspension will absorb carbon dioxide and release oxygen. The algae require light and nutrients, and excess algae must be harvested. Algal cultures in such gas exchangers can use urea as a source of nitrogen, but tests show that they cannot use untreated urine; it is not known whether some elements of untreated urine kill the algae or whether the algae need nutrients which are not in urine. In any case, the urine must be pre-treated and is not a sufficient food for the growth of algae.

The growth of algal cultures is directly dependent upon the intensity of sunlight available at the point at which the culture is being grown. This decreases very quickly with distance. The sunlight brightness at Jupiter is just above the "compensation point," the point at which a plant absorbs carbon dioxide in photosynthesis faster than it makes it by respiration. For trips beyond Mars, photosynthesis by sunlight is probably not practical. Sunlight intensities at various distances from the sun are given in table two, taken from N. W. Pirie.²³

CONTINUED ON PAGE 32

	Distance From Sun (Million Miles)	Distance From Sun, Squared Distance of Earth From Sun, Squared	Relative Intensity of Sunlight
Mercury	36	.15	6.7
Venus	67	.52	1.9
Earth	93	1	1
Mars	142	2.3	.45
Jupiter	483	27	.03
Saturn	886	91	.01
Uranus	1783	370	.003
Neptune	2793	910	.001
Pluto	3660	1560	.0006

Find a career expanding and improving the Bell System



Microwave relay towers assure reliable land transmission of telephone, radio, television and data traffic—with complete flexibility.

To serve a growing America, we are steadily enlarging our communications system . . . opening new route-miles of cable and microwave . . . bringing more customers into the network . . . adding new services.

As a result, the Bell System offers unique career opportunities to ambitious young engineers who want to work on projects commensurate with their talents.

In the Bell System there are literally hundreds of intriguing engineering assignments ranging from the planning of telephone service for large communities to the development of miniaturized components for equipment. A Bell System career can bring an engineer an exciting variety of tasks, every one important, with everything needed to carry them out.

The Bell System companies are equal opportunity employers that match the benefits, salaries and working conditions of other companies. Few can match them, however, for work that is interesting and important.

You owe it to yourself to investigate your career possibilities in the Bell System. Have your Placement Office arrange a date with our interviewing team, or get in touch with a local Bell operating company. Either way, we'll welcome a chance to talk with you.



BELL SYSTEM

American Telephone & Telegraph Co.
and Associated Companies



C. S. LONG LINES lays and maintains Bell System undersea telephone cables that provide dependable overseas transmission.

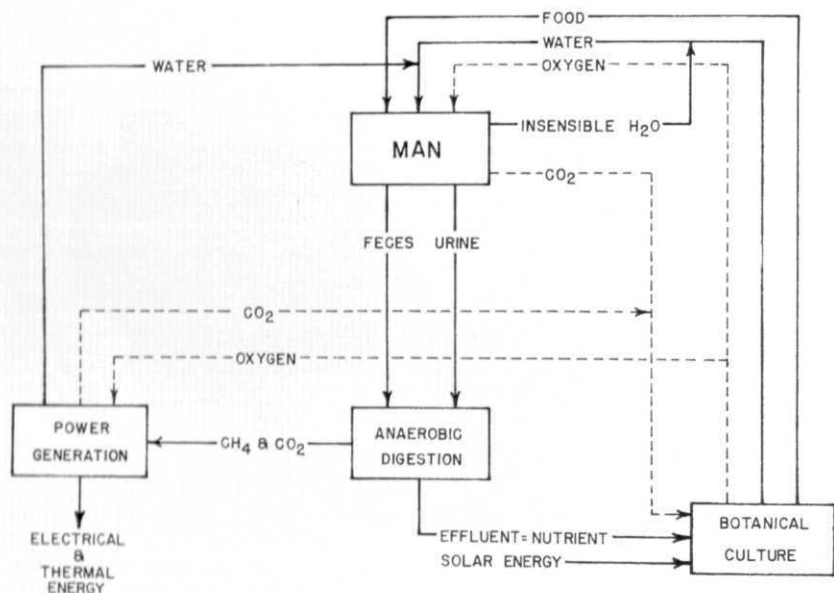

Figure 6: BIOLOGICAL WASTE RECOVERY SYSTEM (HENDEL)

CONTINUED FROM PAGE 30

The design and maintenance of algal cultures, which can be used to purify wastes, convert carbon dioxide, and produce food for human beings, has been investigated at some length. It will, no doubt, be well developed during this generation.

Totally closed environmental control systems will certainly become a reality in the near future. For medium range missions (200 to 600 days), systems similar to that in Figure six become practical.²⁴

RESEARCH

There is a critical need for research in several areas related to the recovery of water from wastes in the space environment. One of these is the recovery of usable water (about 1/4 lb. per day) from feces. Another is water purification by reiterative bacteria. Additional data on thermosmosis is also needed. On long-duration trips (one year or more), it will become profitable to recover minor wastes such as nitrogen from solid and liquid waste products and place them in useful form. Work on systems to recover these wastes from human excrements will be demanded. More investigation of the treatment of urine for use as a nutrient for algae in photo-synthetic gas exchangers is also needed.

The functional activities of the various body organs account for

an estimated 25% of the resting metabolism. It may be worthwhile on long term space trips to reduce body requirements by the use of artificial body parts—lungs, kidneys, and others will probably be available. In addition, it has been shown that the application of reverse forces makes muscles partly reverse their metabolic cycles. It may one day be possible to run metabolic processes in vivo on outside energy, or to run these processes in reverse by applying outside energy, reproducing substances used in metabolism. This area, too, merits further investigation.²⁵

FOOTNOTES

18. T. Crook, "For Drinking in Space; Liquids Purified by Freezing" (Abstract) *Machine Design*, XXXLV (August 30, 1962), p. 8.
19. Hendel, *Op. Cit.*, pp 1854-1855.
20. Hawkins, *Op. Cit.*, pp 528, 531.
21. Hendel, *Op. Cit.*, pp 1856-1858.
22. R. J. Jasinski and T. G. Kirkland, "Fuel Cells" *Mechanical Engineering*, LXXXVI (March, 1964), pp. 52, 53, (April, 1964), pp. 122, 123.
23. N. W. Pirie, Ed., *The Biology of Space Travel*, p. 22.
24. Hendel, *Op. Cit.*, p. 1855.
25. Pirie, *Op. Cit.*, p. 27.

BIBLIOGRAPHY

- Anonymous, "Men Live Seven Days in Closed-Cycle System," *Chemical Engineering*, LXIX (November 26, 1964), p. 68.
- Anonymous, "Nutrition," *Encyclopedia Britannica*, 1963 Edition, XVI, pp. 650 - 654.
- Crook, T., "For Drinking in Space; Liquids Purified by Freezing," (Abstract), *Machine Design*, XXXIV, (August 30, 1962), p. 8.
- Flaherty, Bernard E., ed., *Symposium on Psychophysiological Aspects of Space Flight*, (Brooks Air Force Base, Texas, 1960), New York, Columbia University Press, 1961.
- Harrow, B., and Maeur, A., *Textbook of Biochemistry*, (Sixth Edition), Philadelphia, W. B. Saunders, 1954.
- Hawkins, W. R., "Feasibility of Recycling Human Urine in a Closed Ecological System," *Journal of Aviation Medicine*, XXIX (July, 1958), pp. 525 - 534.
- Hendel, Frank J., "Recovery of Water During Space Missions," *ARS Journal*, XXXII (December, 1962), pp. 1847 - 1859.
- Jasinki, R. J., and Kirkland, T. G., "Fuel Cells," *Mechanical Engineering*, LXXXVI (March, 1964), pp. 51 - 57, and April, 1964, pp. 121 - 126.
- National Aeronautics and Space Administration, *Manned Spacecraft Center, Mercury Project Summary, Including Results of the Fourth Manned Orbital Flight, May 15 and 16, 1963*, Washington, D. C., National Aeronautics and Space Administration, October, 1963.
- Office of Science and Technology, Executive Office of the President, *An Assessment of Large Nuclear Powered Sea Water Distillation Plants*, Washington, D. C. March, 1964.
- Pirie, N. W., ed., *The Biology of Space Travel*, London, Institute of Biology, 1961.
- Popma, Dan C., "Life Support for Long-Duration Missions," *Astronautics and Aerospace Engineering*, I (August 1963), pp. 53 - 56.

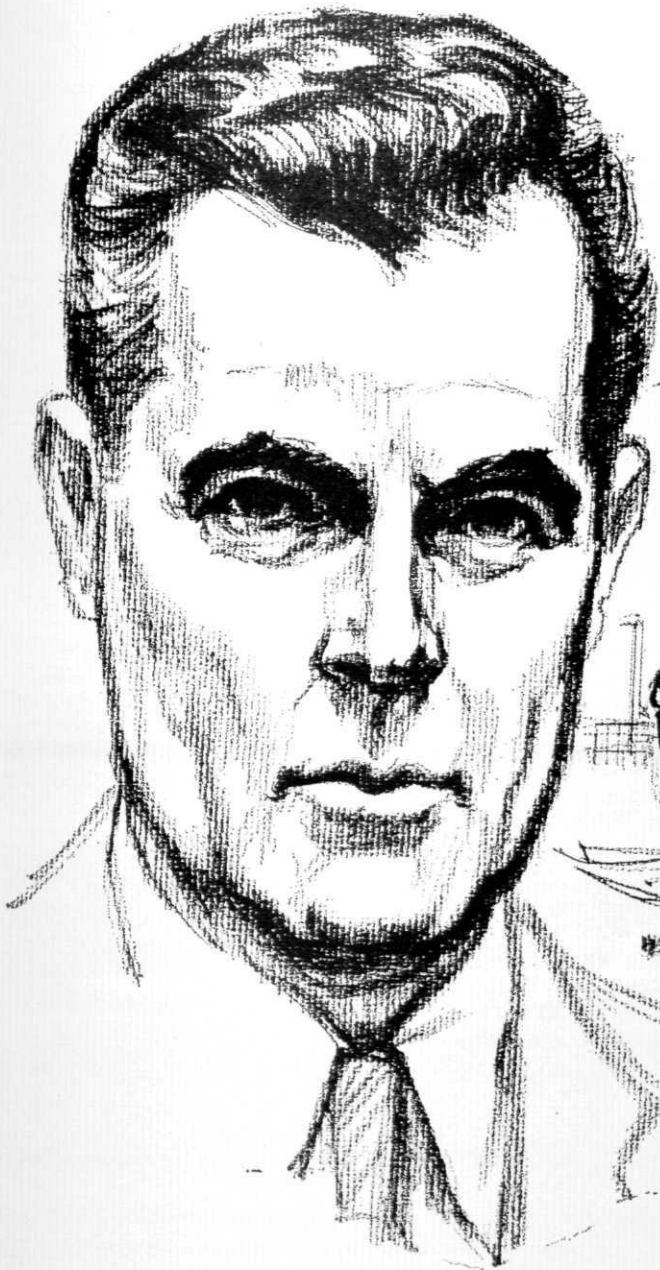

Today's engineers shape tomorrow's future—all over the world

YOUR FUTURE, as well, is of great interest to United States Rubber. With our record of steady growth and continuing diversification, we have a constant need for qualified engineers and the opportunities we offer are most rewarding. Our engineering service organizations provide consulting specialists and civil, electrical, mechanical and industrial engineering services to R&D laboratories and to our manufacturing plants as well as to our foreign and domestic subsidiaries.

Personnel are selected from both within and outside the company to provide an organization with a diversity of specialized knowledge. This knowledge covers modern scientific and engineering techniques in the construction and installation of new facilities and the modernization of old.

Timely, efficient problem service, facility planning assistance and design services for U.S. Rubber laboratories and plants throughout the world are the goals of service and plant engineering. You would be part of a coordinated team of specialists operating in such areas as:

- Power services and utilities
- Electrical distribution equipment and controls
- Stress analysis, structural design and building construction
- Industrial heating and air conditioning
- Process design and design and layout of process equipment
- Heavy machinery design and installation

UNITED STATES RUBBER 1230 Avenue of the Americas, New York 20, N. Y.
An Equal Opportunity Employer

THE FIELD IS WIDE "U.S." offers a comprehensive variety of career opportunities to those with degrees in *Physics, Mathematics and Chemistry* as well as to *Chemical, Mechanical, Industrial and Textile Engineers*. Contact your placement office to determine when a U.S. Rubber recruiter will visit your campus. Before you decide on your first job, have a talk with him.

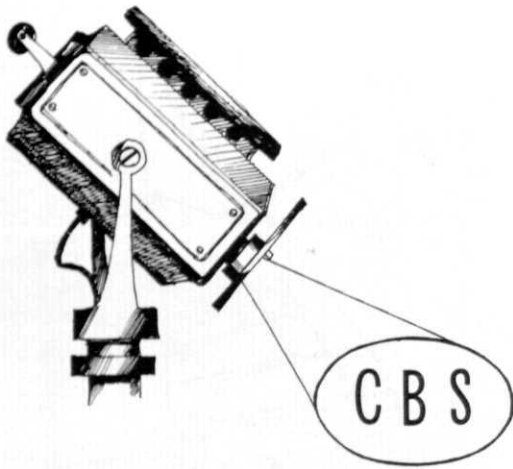

INDUSTRIAL SPOTLIGHT

In the Fall of 1964, Mr. and Mrs. American Voter went to the polls as usual, cast their ballots for an assortment of Congressional and state candidates, and then turned to their favorite news source to find out how the elections were coming along.

And as usual, it seemed as if the "races" had just begun, because the first scattered precincts were reporting, and the early returns were going up on the scoreboard. First, Candidate X was leading by a few votes; then Candidate Y showed a surge of strength and pulled ahead.

The "race" may have seemed exciting, but it was pure illusion. In fact, there was no race at all, and there never had been. Elections were over when the polls closed; either X or Y had been elected. The only "race" going on was among the news media, trying to get the votes counted and reported as soon as possible.

But the tradition of the vote collection "race" was old and well established. Mr. and Mrs. Voter were used to that style of election reporting. It was what they expected, and it was what they got--unless they were tuned to CBS News.

For CBS News, in 1962, was up to something entirely new and different.

In Michigan, with Democratic incumbent John Swainson ahead in the vote count by 74,000, CBS News reported Republican George Romney elected Governor. Hours later, the vote count

for Romney began to pile up, and some Michigan viewers darkly suspected that CBS News was using witchcraft.

In Massachusetts, Governor John Volpe conceded to his Democratic opponent, Endicott Peabody. Reporting Volpe's concession, CBS News continued to declare that the contest was really too close to determine a winner. And, sure enough, as the hours wore on, the count of Volpe's vote drew even with Peabody's. (It took weeks, and a statewide recount, to determine to everyone's satisfaction that Peabody had, in fact, won -- by two-tenths of one per cent of the vote).

Vote Projection Analysis is like printing a picture composed of many thousands of dots, and then screening most of them out. If you make the right selection of dots that remain, the picture will still be recognizable -- and the same thing is true for the politics of a state.

The problem is to make the right selection of voters. This requires monumental research -- a job that is being carried on continuously throughout the United States by VPA research teams, including representatives of CBS News, IBM, and Louis Harris and Associates.

VPA research is based on an important observation about voters--that people tend to vote in patterns, according to socio-ethnic groups. Historically, people of similar background, age, education, and status, who also live close together and do sim-

ilar kinds of work, have displayed similar patterns of political behavior. Obviously, this does not mean that the group's proportionate support of a ticket tends to be similar within a state and for any given election.

The voting population of every state in the Union is made up of such socio-ethnic groups. The number of groups, and their character and relative strength, vary from state to state. But within any given state, it is possible to find out who the groups are, where they live, how they have voted in past elections, and what they think about the current political candidates and issues.

To do this, VPA researchers study Bureau of Census data, demographic reports and precinct voting records; they draw scientific samples of the voting population and poll them as a check on existing statistics.

By the time they are through, the researchers know more about the voting population of the state than the voters know about themselves--more, in fact, than anyone had ever known before.

A model state, will consist of 32 to 60 selected precincts, depending upon the size and composition of the electorate. These precincts will form a cross-section, reflecting the various voting groups in the state. To test the model, the precinct data is programmed into computers, which compare the actual statewide vote in previous elections with the total vote from the model precincts in those same elec-

CONTINUED ON PAGE 36

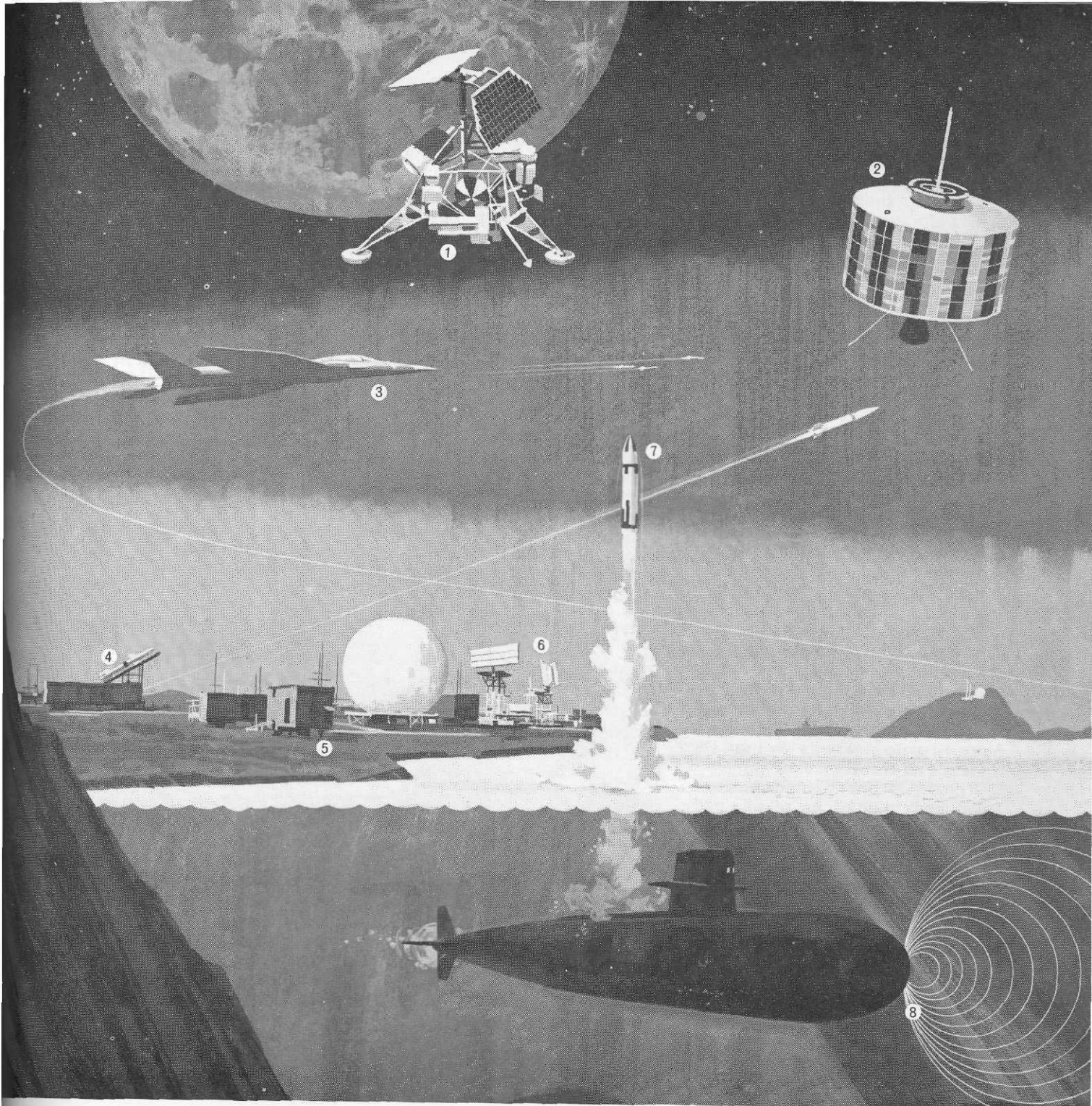

Opportunities at Hughes for EE's—Physicists—Scientists:

from the ocean floor to the moon...and beyond

Hughes sphere of activity extends from the far reaches of outer space to the bottom of the sea... includes advanced studies, research, design, development and production on projects such as: ① **SURVEYOR**—unmanned, soft-landing lunar spacecraft for chemical and visual analysis of the moon's surface; ② **SYNCOM** (Synchronous-orbit Communications Satellite)—provides world-wide communications with only three satellites; ③ **F-111B PHOENIX** Missile System—an advanced weapon system designed to radically extend the defensive strike capability of supersonic aircraft; ④ **Anti-CBM Defense Systems**—designed to locate, intercept and destroy attacking enemy ballistic missiles in flight; ⑤ **Air Defense Control Systems**—border-to-border control of air defenses from a single command center—combines 3D radar, real-time computer technology and display systems within a flexible communications network; ⑥ **3D Radar**—ground and ship-based systems give simultaneous height, range and bearing data—now in service on the nuclear-powered U.S.S. Enterprise; ⑦ **POLARIS** Guidance System—guidance components for the long-range POLARIS missile; ⑧ **Hydrospace**—advanced sonar and other anti-submarine warfare systems.

Other responsible assignments include: ATS (advanced technological satellites), TOW (wire-guided, anti-tank missile system), VATE (automatic checkout equipment), advanced infrared systems, electronic signal processing, space communications, parametric amplifiers, airborne radar systems, reconnaissance systems, aerospace vehicle development, missile/spacecraft power & propulsion systems...and others.

B.S., M.S. and Ph.D. Candidates CAMPUS INTERVIEWS February 22, 1965

Learn more about opportunities at Hughes, our educational programs, and the extra benefits Southern California living offers. For additional information and literature, consult your College Placement Director. Or write:

Mr. A. J. Simone
Hughes Field Service & Support
P.O. Box 90515
Los Angeles, Calif. 90009

Creating a new world with electronics

HUGHES

HUGHES AIRCRAFT COMPANY

U. S. CITIZENSHIP REQUIRED
An equal opportunity employer.

tions. The model as a whole must accurately reflect the political behavior of the state, and research goes on until it does.

Nor does the research end once a satisfactory model has been built. Precincts, like politics, do not stand still. New apartment or highway construction, for example, may change the voting population of precincts so that they no longer fit the model. The precincts must be studied constantly, and the research validated. It's a continuous process that goes on right down to the election eve.

By now, it should be clear that VPA election night results are not based on guesswork, but hard work, and lots of it.

Twenty - one months of intensive research from coast to coast, seven million dollars worth of computing equipment--largest and most extensive data processing complex ever assembled for election reporting--and a special corps of reporters in some 2,000 precincts were utilized to provide early indications of winners and analyses of voting trends by the CBS News Vote Profile Analysis on the CBS Television Network Nov. 3.

Results from VPA precincts furnished indications of who had won or was leading in each state and the factors which shaped the result. In the same manner as the President is actually elected, VPA reports indicate what had happened on a state - by - state basis, and only when VPA shows that states totaling a majority (270) of the electoral votes have been won is a national result indicated. In 48 states and the District of Columbia, roughly 2,000 precincts are selected for in-depth research prior to the election. (Alaska and Hawaii are not included.) Data polling, not opinion polling, is a principal method of research for VPA precincts; that is, data on past voting history, economic, religious, geographic and ethnic breakdown of the population are collected. To augment and confirm this data polling, VPA researchers gather information from census bureau studies, county courthouse records, personal observation and interviews with county and precinct officials. The complete data on each of the 2,000 VPA precincts then are programmed into the computer complex,

On the basis of VPA results, CBS News correspondents reporting on Presidential, Senatorial and Gubernatorial races will have a quick and useful method of comparing the Nov. 3 voting pattern with the entire voting history of an area, arriving at a judgment as to what has happened in a particular state.

The IBM computer system, similar to that used in business and industry, provided the corps of CBS News correspondents covering the election with meaningful data which enabled them to explain the "why" as well as the "what" of the election returns. The computer system formed the heart of CBS News Vote Profile Analysis, state - by - state projections of early returns from carefully selected and researched precincts which provide accurate and early indications of

what had happened and the voting behavior behind the results.

While VPA is based primarily on political science and extensive research, the system is so complex -- utilizing returns, past voting information and associated data on more than 2,000 separate precincts throughout the nation -- that its use on Election Night would not be possible without the IBM Computer system.

At the same time, the computer's role in Vote Profile Analysis is the same as its application to industrial uses; it can process vast amounts of data in extremely short periods of time, enabling management to make speedy decisions.

The system therefore was primed to produce and deliver on demand hundreds of statewide reports for CBS News cor-

CONTINUED ON PAGE 38



Uncertain about these career decisions?

- a. Join a large company? () or medium? () or small company? ()
- b. Prefer to work in systems analysis and techniques? () or on equipment design? () or multi-unit large systems? ()
- c. Aim to be a Technical Specialist? () or Administrative Manager? () or Program/Project Manager? ()
- d. Have an advanced degree in your sights? () or feel BS is sufficient for satisfying career growth? ()

Don't worry!

For those graduates who are uncertain regarding their career plans, we welcome the opportunity to discuss the wide variety of interesting and challenging assignments available with Sylvania Electronic Systems. SES is equipped to foster the professional growth of graduates with widely differing goals. This is possible primarily because SES is actually a highly diversified complex which encompasses 19 R&D laboratories, 4 manufacturing plants and a world-wide field engineering operation. The Division's mission is to manage government systems programs for General Telephone & Electronics, the parent corporation.

The small group form of organization—a traditional small company advantage—is practiced at SES to encourage individual progress and development. SES offers its personnel absorbing assignments to perform, yet also affords a bird's-

eye view of the total picture in advanced electronics.

A wide variety of current in-house projects enables you to move right into the heart of today's most advanced developments in electronic systems. You may start here in a technical or administrative capacity in any one of these broad areas: space/earth communications • electronic reconnaissance • detection • countermeasures • information handling • arms disarmament and control • sophisticated electronic networks such as the ground electronics system supporting Minuteman command and control functions.

Finally, opportunities are numerous for ambitious individuals to accelerate their advancement through participation in division-wide conferences, in-plant courses and seminars, and post graduate study plans conducted on an unusually generous scale.

GTE

GENERAL TELEPHONE & ELECTRONICS
Total Communications from a single source through

SYLVANIA ELECTRONIC SYSTEMS

SES LABORATORIES ARE LOCATED SUBURBAN TO SAN FRANCISCO, BUFFALO AND BOSTON

For further information about any of these locations, see your college placement officer or write to Mr. Robert T. Morton
40 Sylvan Road — Waltham, Massachusetts 02154. An Equal Opportunity Employer

respondents providing facts on socio-ethnic voting patterns, on comparisons with past elections and, of course, immediate information on selected returns that evening. These reports, continually updated as additional precincts report in throughout the evening, provided the correspondents with the most detailed data on voting trends in the history of election reporting.

Prior to Election Night, the system was utilized to help develop and select the most representative precincts in each state. The computers are used to compare groups of combinations of precincts and to check their mathematical reliability in terms of precinct votes in prior elections compared with area and state-wide votes in the same elections. The system processes millions of combinations to select the best 2,000 precincts out of some 8,000 possible precincts already researched.

On Election Night, CBS News vote reporters at the 2,000 precincts telephoned vote returns from these precincts to CBS Studio 41.

The entire computer network is what is known as a real-time system -- a system which processes information as it occurs -- comprising 30 IBM 1050 data communications units and an IBM 1440 computer linked to an IBM 7010/1301 system. It is valued at approximately \$7,000,000. Information was relayed to IBM operators who key the data into a 1050 "terminal" system. This, in turn, fed it into a 1440 computer which checked the data against previously gathered information for obvious errors. If the phoned information was verified, it was fed back into the 1050 and, simultaneously, to the 7010 computer on the floor which printed out the information. If the 1440 finds a discrepancy, it is automatically relayed to a trouble-shooting desk from where the precinct reporter involved was queried about his data.

On Election Night, Studio 41 was manned by more than 200 CBS News employees -- correspondents, production and technical personnel -- not counting the IBM crews.

As precinct reports arrived and were fed into the system,

they were stored into the computer cells assigned for the vote returns in each precinct. As more and more precincts from within a state were heard from, an analytical report on the returns thus far from the state was ready to be produced. At a given point--when 20 out of 42 precincts have reported, for example -- the system produced an extensive report on the race involved.

The report contained results by percentage for each precinct reporting; it contained results by regions of the state, by areas of varying population density (city, suburbs, town and rural), by religious groups and by ethnic groups; it did, in each case, show comparisons for the same precincts and same groups with comparable races in the past (the 1960 Presidential race, for example, as well as 1962, 1960 or 1958 Senatorial or Gubernatorial races).

The IBM system may have produced as many as four reports for each race in each state, and in fact, more on demand. The final such report, of course, was produced when all of the VPA model precincts have reported.

In addition, the computers produced Presidential Summary Reports, summarizing the Presidential race in 48 states and the District of Columbia on a periodic basis, and including regional breakdowns on voting behavior by area of population density, religion and ethnic groupings.

With 108 separate races scheduled for VPA, therefore, it was expected that nearly 500 of the exhaustive reports would be produced by the IBM computer system during the evening, each of them involving hundreds of facts and calculations.

On that night, viewers saw a fan-shaped, multi-level setting showing the Presidential Board and 51 State Boards (including the District of Columbia), as well as Vote Profile Analysis Estimate Boards, with more than 300 separate digital display panels covering each of the principal races in each state at its perimeter. In front of these boards and corresponding to them from left to right, was the Gubernatorial Desk, manned by CBS News Cor-

respondent Mike Wallace; the Presidential Desk, with Harry Reasoner and Roger Mudd; the Congressional Desk, with Robert Trout; and the National Analysis Desk, with Eric Sevareid and Martin Agronsky, all within a few feet of each other. In the center, facing these four desks, was CBS News Correspondent Walter Cronkite, acting as National Editor in charge of the National Desk.

A large screen was installed behind the National Desk, to be used for display of remote pickups from various parts of the country.

A minimum of 12 cameras were deployed throughout the studio, including four mounted on a 17 1/2-foot platform facing the Vote Board. Some 55 teletype machines -- including those of the Network Election Service, the wire services and internal communications -- were utilized.

More than 2,600 individual Digital Display Unit components on the 300 DDU panels posted the results of the VPA analysis and of the raw vote figures supplied by the Network Election Service. These DDU units, first used during the 1962 election coverage by CBS News, were designed and built by CBS Laboratories, in collaboration with CBS Television Network production specialists. Each DDU unit contains numerals from zero to nine, with the white-on-black figures rotating on a shaft and flipping to a designated number like the pages of a book. Eight such units, mounted side by side, will be able to record up to 99,999,999 numbers.

Each of these grouped units was linked to and controlled by a console. As figures are reported in, they are set up on the consoles and, by push button, changed instantaneously. Thus CBS News was able to speed up the posting of figures to within seconds after they are phoned in and evaluated.

Thus research, interpretation, and data processing were the three keys to vote projection analysis. Opinion analysts Lou Harris and associates are primarily responsible for the first, CBS News for the second, and IBM computer systems for the third.

SE

"The development of management is essential to our goal of great growth"



At the 1964 stockholders' meeting, Arjay Miller, President of Ford Motor Company, emphasized the Company's far-sighted recruitment program and its accent on developing management talent:

"One aspect of our planning is crucial to the success of everything else we do. It engages the best thoughts and efforts of our whole management team, from top to bottom, throughout the world. I am speaking of the development of management. The immediate future of our Company depends heavily upon the abilities of the people who are now key members of our management team.

"In the longer run, our future depends on what we are doing at the present time to attract and develop the people who will be making the major decisions 10 to 20 years from now. We are developing management competence in depth in order to attack the problems that will confront a company of great growth—and great growth (both in profits and sales) is exactly the goal we have established for Ford Motor Company.

"We are continuing to emphasize recruiting. Last spring, 180 of our management people devoted part of their time to recruiting outstanding graduates from colleges and universities throughout the U.S. Last year, these efforts resulted in our hiring over 1,000 graduates, 220 more than the year before.

"We are seeking and we are finding young men—and young women, too—with brains and backbone—people who have the ability and the desire to make room for themselves at the top. We give our trainees challenging assignments with as much responsibility as they can carry. We promote them as fast as they are ready. Those who are interested in easy security soon drop out. Those who have what we want stay with us, and move up quickly to increased responsibility and the pay that goes with it. Thanks to the quality of the people we are recruiting and developing, I am firmly convinced that our outlook is most promising."



MOTOR COMPANY

The American Road, Dearborn, Michigan

Industrial News

A new sampling instrument named the KH-400 has just been introduced by Welles Products, Inc. The simplicity and accuracy of the device was immediately apparent to others, and at their request, the unit has now been made commercially available.

The KH-400 is opened by depressing a thumb lever at the top and lowered into the liquid in the open position. The clear Plexiglas cylinder is open at both top and bottom - no air can be trapped and carried below. As the instrument is lowered at an angle, a chimney-type flow of the liquid displaces all previous liquid so that at any level, the cylinder is always filled from that precise point. There can be no entrained liquid or air within the cylinder - no contamination of the sample. When the desired depth is reached, a sharp tug on the cord snaps the instrument closed, trapping an accurate sample.

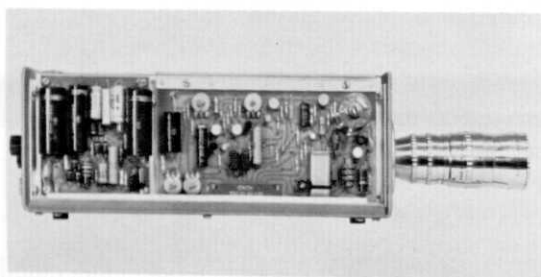

DuMont Laboratories has produced a complete closed-circuit television camera with its own regulated power supply in one small, lightweight package that is ruggedized against environmental shock, vibration, and temperature extremes.

Horizontal resolution of 700 lines, and high signal-to-noise ratio help produce sharp, bright pictures at light levels as low as 10 foot candles scene illumination. Useful pictures can be obtained with scene illuminations as low as 1 foot candle. The camera may be fed directly to a convenient TV receiver. An additional output provides for interconnection with any high resolution monitor.

Westinghouse engineer J. R. Hansen prepares to view the complicated patterns in a laser beam, with a new infrared pattern viewer developed at the Westinghouse Research Laboratories. The "eye" of the viewer is a thin film of liquid crystals mounted in the round vacuum cell at the center of the picture. When the beam from the laser (rear) strikes the film, its heat will cause the crystals to shift in color and display the beam's structure. Lamps in the housing in the foreground are used to adjust the temperature of the film and to provide the exact amount of illumination to it.

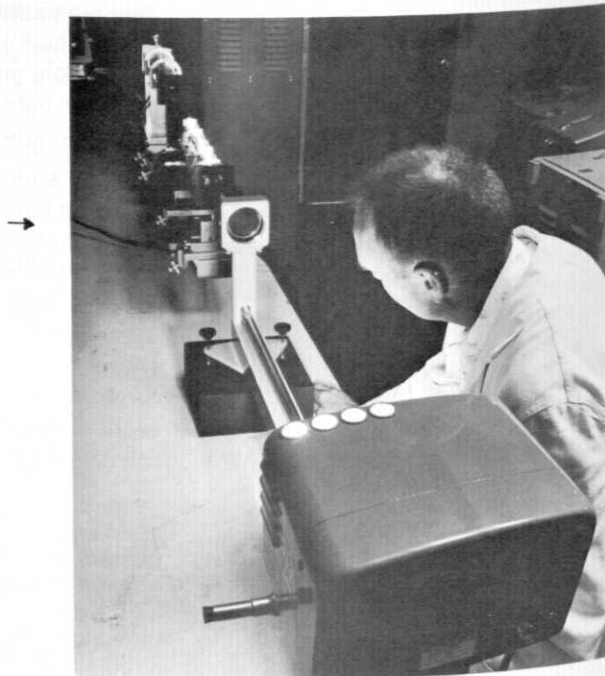

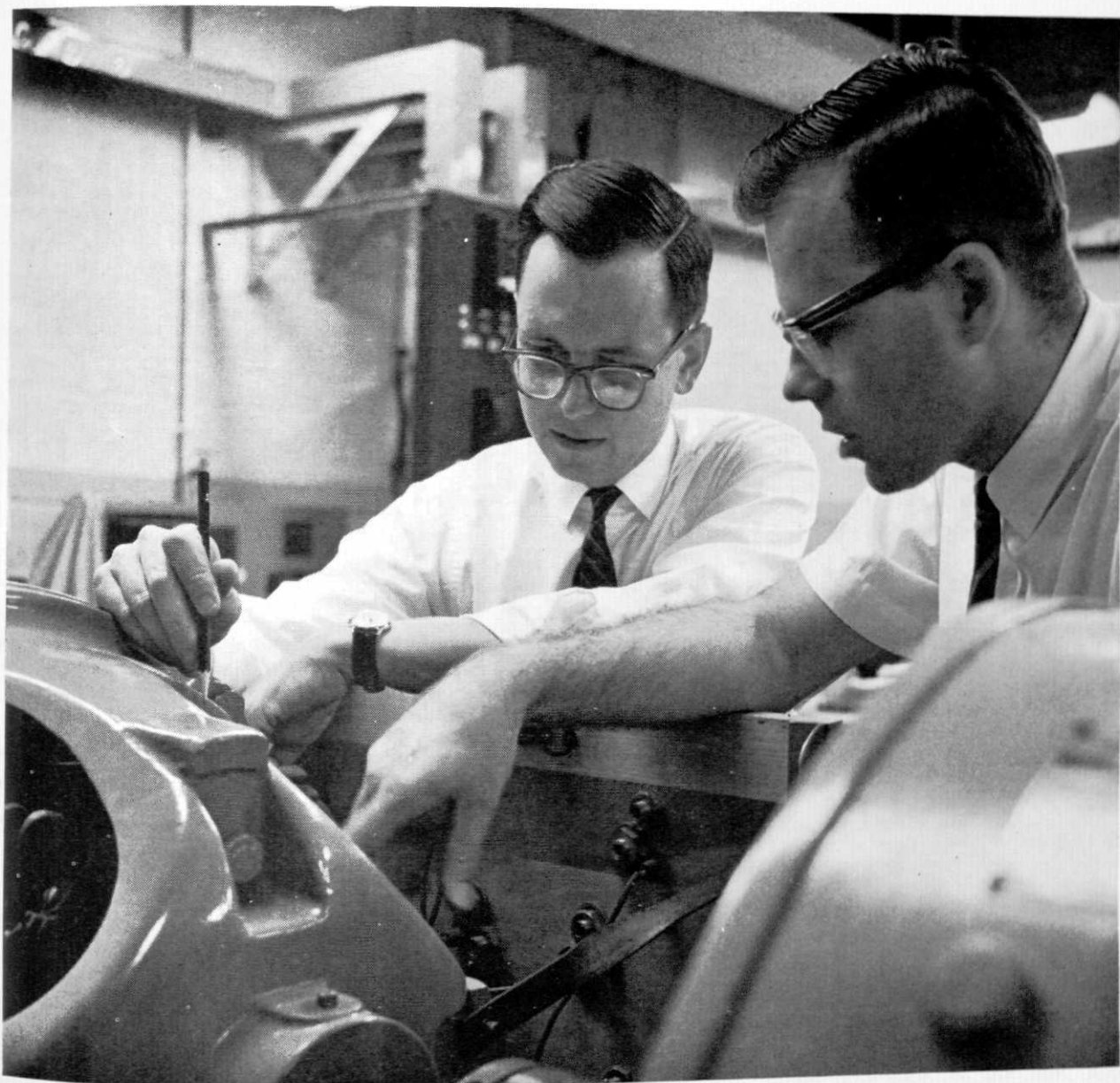

Detroit Edison and Consumers Power Company are jointly sponsoring research at the University of Michigan, devoted to advanced mathematical methods for power system sta-

bility analysis and generator field control. Shown are Professor Anthony J. Pennington (left), director of the project, and James Bennett, a graduate student.

Campus research is important to Detroit Edison

Detroit Edison supports research activities at many engineering universities and receives valuable information from these joint programs. Here are some of the projects now under way at University of Michigan, Iowa State University, Kansas State University and Rose Polytechnic Institute.

- Power System Stability Analysis and Generator Field Control
- Analysis of Conductor Vibration
- Modern Solutions for Power Networks
- Mathematical Models for Peak Load Forecasting
- Block Diagram Representation of a Power Generating Unit—a first step in stability analysis
- Thermionic Conversion

Research projects such as these provide a challenge for both professors and students alike. This challenge continues after graduation in our research laboratories and engineering departments because interesting things are happening at Detroit Edison.

If you're graduating this year and want to put your ideas and energies to work—write to Mr. George Sold, The Detroit Edison Company, Detroit, Michigan 48226. And look for the Edison personnel representative when he visits your campus.

DETROIT EDISON
SERVING SOUTHEASTERN MICHIGAN

COLLEGE OF ENGINEERING

and

JETS

ANNUAL ENGINEERING EXPOSITION and CONFERENCE

will be held at

MICHIGAN STATE UNIVERSITY

East Lansing, Mich.

MAY 14-16, 1965

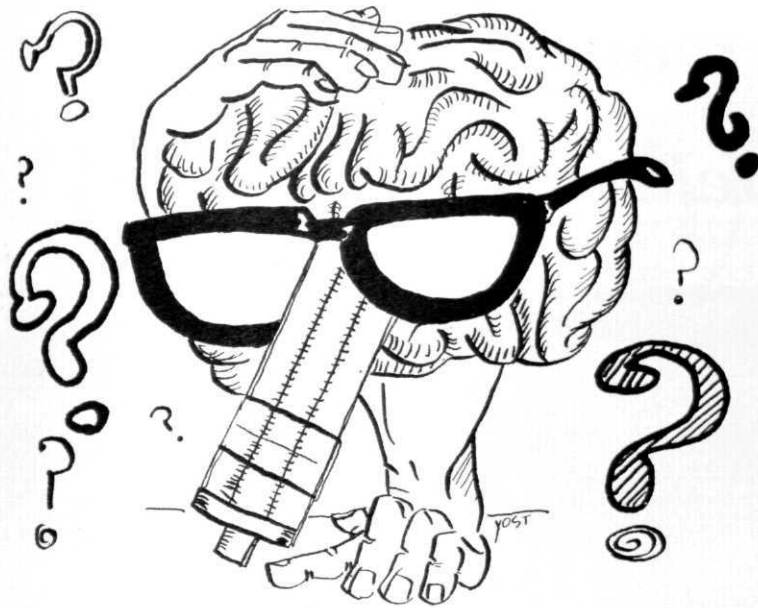

BRAIN SPRAINERS

EDITOR'S NOTE: Answers to the following puzzles will appear in the March issue of the Spartan Engineer.

A man is on a bridge from A to B, $\frac{3}{8}$ of the way across from A. He hears a train approaching A at a rate of 60 mph. If he runs towards A he will meet the train at A; if he runs towards B the train will overtake him at B. How fast can he run?

SE

A garrison had bread for 11 days. If there had been 400 more men, each man's daily share would have been 2 ounces less; if there had been 600 fewer men, each man's daily share could have been increased by 2 ounces and the bread would have lasted 12 days. How many pounds of bread did the garrison have?

SE

A farmer, as a present, gave his son all the land the son could separate in a rectangular plot with 600 yards of fence. The son, however, used part of a pond as one side of his plot. Find the maximum area the son could have received.

SE

In a series of games: Jim beat Frank, and John; Frank beat Joe, Tom and John; Joe beat Jim and Tom; Tom beat Jim and John; John beat Joe. Rank the players according to their winning ability.

SE

If $\frac{1}{4}$ of 20 is 6, then what is $\frac{1}{5}$ of 10?

SE

At a party there are: 14 girls, 11 adults without costumes, 14 women, 10 girls with costumes, 24 people without costumes, 8 women with costumes, and 10 males with costumes. How many people are at the party?

SE

Answers to last issue's problems:

1. Alfred-30, Bill-18, Charles-28
2. The statement is valid.
3. Twenty-three men.
4. $2 \times 9 + 6 - 7 = 17$ or $\sqrt{296} - 7 = 17$
5. Smith forgets to bring his wife flowers; there is no independence.

SE

Men on the move at Bethlehem Steel



JIM DAVIS, CH.E., GEORGIA TECH '59
—Jim is a salesman in our Chicago District. His technical training has been a valuable asset in selling steel products.

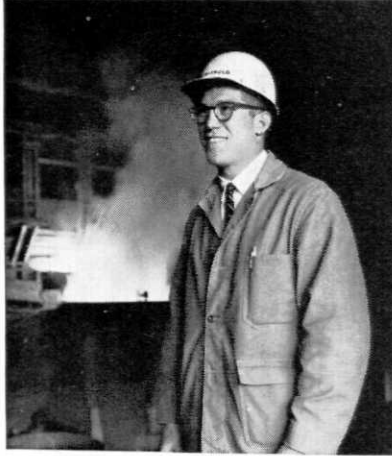

LEON HARBOLD, MET.E., LEHIGH '59
—Leon's many assignments around the open hearths at our Sparrows Point, Md., Plant led to his latest promotion as Assistant to the Superintendent of #3 Open Hearth.



DENNIS WITMER, CH.E., MARYLAND '61
—An engineer at our research laboratories in Bethlehem, Pa., Dennis is shown using a microprobe to study corrosion-resistant coatings on sheet steel.



FRED EWING, C.E., CARNEGIE TECH '60
—Fred is a turn foreman, supervising a force of 130 men in the rod and wire mills at our Sparrows Point, Md., Plant, the nation's largest steel plant.



FRANK PERETIN, E.E., PITT '60
—As an engineer in the Johnstown, Pa., Plant Electrical Department, Frank's duties involve power generation and distribution, drive systems, and electronic controls.

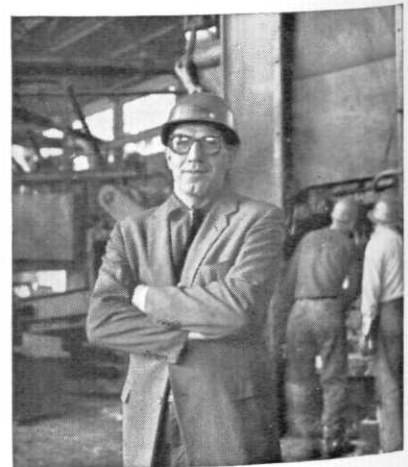

BILL BALLEK, M.E., LAFAYETTE '62
—As turn foreman in the Bethlehem Plant forge shop, Bill supervises hammer forge and mechanical press operations. He also coordinates quality control for the entire shop.

These alert young men are a few of the many recent graduates who joined the Bethlehem Loop Course, one of industry's best-known management development programs. Want more information? We suggest you read our booklet, "Careers with Bethlehem Steel and the Loop Course." Pick up a copy at your Placement Office, or write to our Manager of Personnel, Bethlehem, Pa.

An equal opportunity employer

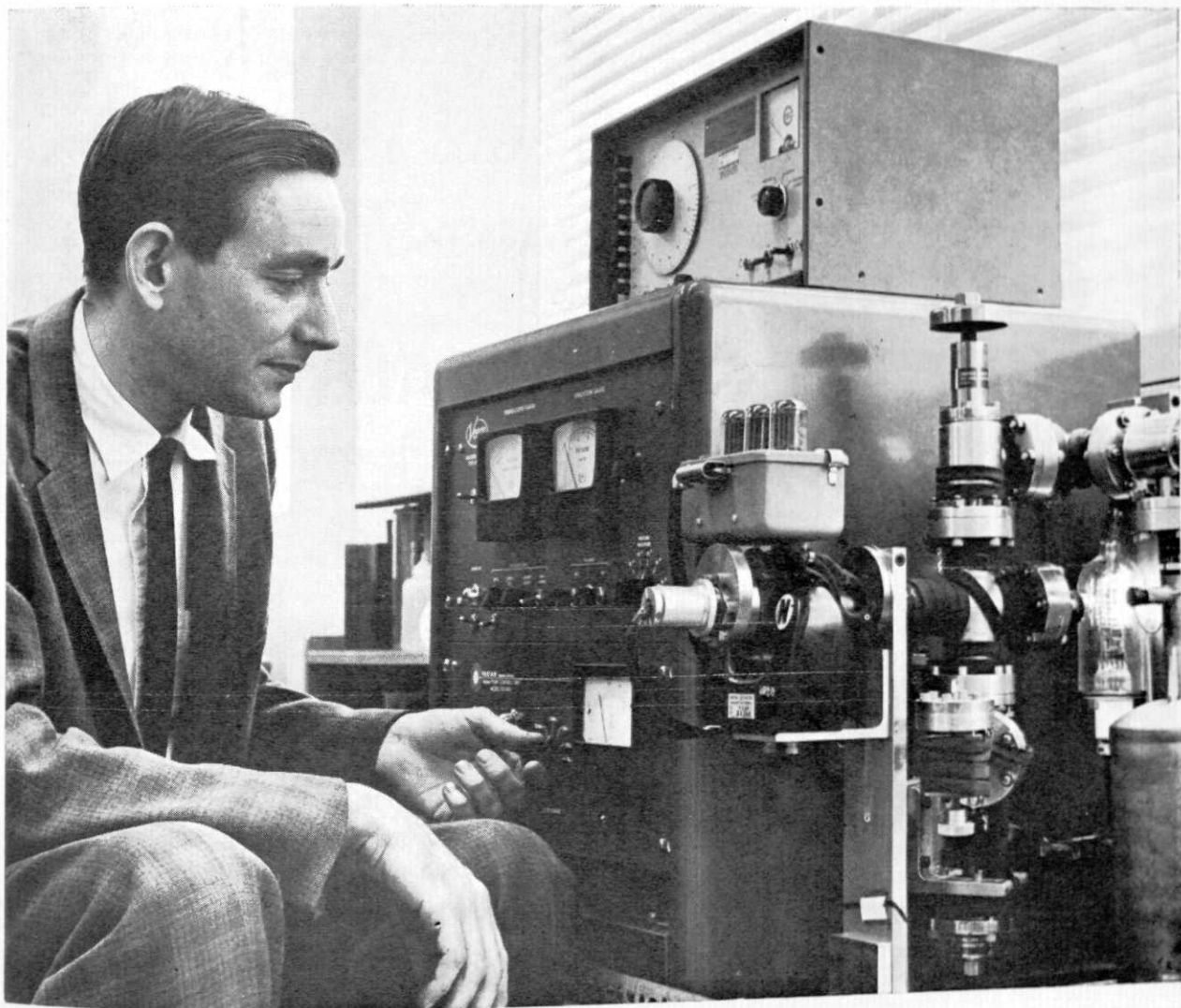

FROM CAMPUS TO CAREER WITH DELCO RADIO

Just 10 years ago, Max Stanton received his BA in Physics from Indiana University.

Today, Max is a senior project engineer at Delco Radio Division of General Motors Corporation in Kokomo, Indiana.

Max is shown above analyzing gas ambients found in sealed transistor enclosures. The system—a residual gas analyzer—is pumped down to a low vacuum with an absorption tank and vacuum pump. Then a transistor is punctured and the gas introduced into the analyzer. Using mass spectrographic techniques, an analysis of the constituents through mass number 80 can be made. Such analyses are helpful in the study of surface ef-

fects in solid state devices.

Max Stanton has established a challenging and satisfying career with Delco—the electronics division of General Motors. As a young graduate engineer, you, too, could

An equal opportunity employer

solid state electronics



**DELCO RADIO DIVISION
OF GENERAL MOTORS
Kokomo, Indiana**

soon be on your way to a long-time, rewarding career at Delco.

Opportunities exist now in silicon and germanium device development, ferrites, solid state diffusion, creative packaging of semiconductor products, development of laboratory equipment, reliability techniques, and applications and manufacturing engineering.

Our brochure detailing the opportunities to share in forging the future of electronics with this outstanding Delco-GM team is yours for the asking. Watch for Delco Radio interview dates on your campus, or write to Mr. C. D. Longshore, Dept. CR, Delco Radio Division, General Motors Corporation, Kokomo, Indiana.

HISTORY OF THE CALENDAR

EDITORS NOTE: Copies of the following article may be obtained from Clifford A. Reeves M.A., B.D., College Extension Division, 711 Estelle Drive, Orlando, Florida.

The calendar is a convenience so familiar that we take it for granted. Anciently, a device showing the days of the month, and pictured in books or on stone, was called a calendarium. Our present calendar may be traced back to about 738 B.C. when Romulus, according to legend, introduced the Roman calendar. March, the first month, was named in honor of Mars, god of war. April was derived from *Aperire*, to open, the month in which the earth opened for new fruit. May was called in honor of *Maia*, goddess of marriage. June was named after the goddess *Juno*. *Quintilis* was then the fifth month, *Sextilis* the sixth, our September the seventh, October the eighth, November the ninth and December the tenth. To honor Julius Caesar, the month *Quintilis* was changed to July. Caesar Augustus later gave the name of August to *Sextilis*. About 713 B.C. the Roman King Numa Pompilius added the month of January, named after *Janus*, and also introduced February, called after *Februalia*, the time for sacrificing to the gods. Thus, the year now had 12 lunar months, or 354 days, but by the time of Julius Caesar this calendar had become entirely at variance with the equinoxes. So in 46 B.C., he constructed the Julian calendar by borrowing the Egyptian fixed solar calendar of 365 days. An additional day was intercalated every fourth year to complete the 365 1/4 days, but it was not yet entirely accurate. In 1582 Pope Gregory XIII rectified the difficulty by dropping 10 days, so that the equinox may fall on the approximate date on which it fell in 325 A.D., at the Council of Nicea. This Gregorian calendar, which we still use, was immediately adopted by Roman Catholic countries, but later by

Protestant and Greek Catholic countries. We should note that this scheme of revision did not involve breaking the continuity of the weekly cycle. Thursday, October 4 of the Julian calendar was followed by Friday, October 15 under the Gregorian. Long before the seven-day week was adopted by the Romans, the Jews followed a seven-day week in their worship, and the week was no part of the official Roman civil calendar until the reign of Constantine. We find traces of its use in astrological calendars in the first century B.C. showing its connection at Rome with the sun, moon and five planets, which have given their names to the seven days.

It would seem that the creation account given by Moses (Genesis 2:1-3) is the only reasonable explanation for the origin of the weekly cycle. The Encyclopedia Britannica supports this conclusion: "The week is a period of seven days, having no reference whatever to the celestial motions. It has been employed from time immemorial in almost all Eastern countries . . . those who reject the Mosaic recital (that is, the creation account) will be at a loss, as Delambre remarks, to assign to it an origin having much semblance of probability." Vol. IV., p. 988, 11th Edition.

The weekly cycle was instituted by God at the creation of the world, and the 7th day Sabbath marks off the weeks: this day was designed of God to be kept holy as a perpetual memorial of His creative and redemptive powers. Therefore, the weekly cycle is a twin sister of the 7th day Sabbath, the rest day set forth for man in the Bible.

*“Are there any
East Coast labs doing
Organic Research?”*

“How
about
a sales
assignment
in the
Chicago
area?”

“DO YOU
HAVE ANY
MANUFACTURING
FACILITIES
IN THE
SOUTH?”

**“What’s
available
in R & D
around
New York?”**

*“Could I start
at a location with
nearby graduate
schools?”*

“Any chance of
moving around the country?”

ASK 

IF LOCATION is important to you in choosing your first job, why not talk to the company that has 130 plants and research centers throughout the U.S.A., as well as scores of sales offices from coast to coast? Your placement office can tell you when our interviewer will be on campus.

AN EQUAL OPPORTUNITY EMPLOYER

DIVISIONS: BARRETT · FIBERS · GENERAL CHEMICAL · INTERNATIONAL · NATIONAL ANILINE · NITROGEN · PLASTICS · SEMET-SOLVAY · SOLVAY PROCESS · UNION TEXAS PETROLEUM



**Your plans
should
include John Deere**

Our plans include engineers. In order to expand our worldwide network of 22 manufacturing operations, we need good people . . . curious people . . . people with initiative . . . people who can use today's and tomorrow's technology to build better farm, industrial, lawn and garden tractors and equipment.

Organized in 1837, John Deere is the leader in the United States and Canada in farm equipment sales. Total net sales have more than doubled in the past ten years.

Unusual opportunities are offered in tech-

nical fields — research, product design and development, industrial engineering, materials analysis, methods, or plant engineering.

Check your placement office for more information. Or, write to Director, College and University Relations, Deere & Company, Moline, Ill. An equal opportunity employer.

JOHN DEERE

Moline, Illinois



"Company capability is measured by the genius of its people . . . and the tools at their disposal"

Engineers can go nuts without the bolts

Blue-sky theorizing is essential to engineering. In fact, it is the ignition point for all technological achievement. But the best ideas in and out of this world can fail if the proving ground, the testing lab, or the constructive cynicism of mature co-professionals aren't available to question an idea or a product's ultimate function. □ Engineers working without these facilities wind up talking only to themselves — and there's a word for that condition. Hamilton Standard management long ago recognized that in the marketplaces of the aerospace industry, a company's ability to produce a workable article is largely measured by two basic criteria: the genius of its people . . . and the physical resources at their immediate disposal. Hamilton Standard is the "complete" engineering organization. The company is a unique blend of many advanced projects, specialized engineering skills . . . plus exceptional research, laboratory and manufacturing facilities. □ Present projects involve *environmental control systems, engine controls, starters and turbomachinery, air induction controls, propellers, electron beam technology, ground support equipment, electronics, thrust vector controls, bioscience research and spacecraft life support systems*. This broad product range requires, obviously, an engineering team with a wide variety of engineering skills. □ The group of over one thousand graduate engineers and technicians are skilled in such disciplines as Aerodynamics, Cryogenics, Control Dynamics, Electronics (including Micro-

electronics), Electron Optics, Engineering Physics, Fluid Dynamics, Heat Transfer, Hydraulics, Instrumentation, Mechanics, Metallurgy, Physical Chemistry, Servomechanisms, Structures, Stress Analysis, Thermodynamics. Working in Project Task Forces, the men involved multiply their knowledge by mixing intelligence and constantly communicating problems . . . and solutions. □ Available as tools to our engineers are Divisional facilities of over 1.5 million square feet. These facilities have established Hamilton Standard as a world leader in contributing to state-of-the-art advances in vibrations, aerodynamics, hydraulics, and control dynamics, among others. A recently completed space simulator for manned missions will further advance the state-of-the-art in life support systems, when Division engineers outfitted in our space suits conduct tests at a simulated altitude of approximately 1,500,000 feet. □ If you would like to know more about our equal opportunity company, including graduate study programs . . . and the kind of countryside Connecticut living enjoyed by Hamilton families . . . write to Mr. Timothy K. Bye, Supervisor of College Relations, Windsor Locks, Connecticut, or see your Placement Office for an appointment with our representative when he visits your campus.

**Hamilton
Standard**

DIVISION OF

**United
Aircraft**

ENGRINEERS

For Student's edification, we present herewith a portfolio of typical political pronouncements. So that none will miss the full message of these meaningful literary gems, we have asked our experts to restate them in everyday language. We earnestly hope that this clarification will enlighten the student and ease his understanding of the political scene this election year.

Quote: This program is a multi-million dollar giveaway.

Translation: None of this is being spent in my district.

Q: I am shocked that such a thing could happen.

T: How did that get out?

Q: I have the greatest admiration and respect for my opponent.

T: The double-dealing bum.

Q: I feel that the press has not been entirely accurate in its presentation of this matter.

T: I have been caught lying.

Q: I say NO . . . definitely and final NO!

T: For the present I am against it.

Q: . . . and I will demand equal time on television.

T: We'll buy all the time we can get.

Q: I am unalterably opposed to wasting the taxpayer's money!!

T: This is an election year.

SE

Chemistry Professor: "Young man, why aren't you taking notes?"

Freshman: "I don't need to. 'I've got my grandfather's."

SE

"He says I don't know how to dress, huh! Well, tonight I'll wear my new low cut dress and show him a thing or two."

Engineer to Date: "How many beers does it take to make you dizzy?"

Date: "Four or five and don't call me Dizzy."

SE

Tonto and the Lone Ranger are surrounded by 10,000 fierce Indians. "Well Tonto, it looks like the end of us."

"What do you mean 'us', paleface?"

SE

Know what becomes of doughnut holes after the doughnuts are eaten? IBM make a fortune cutting them up in little pieces and pasting them on cards.

SE

Hear about the new deodorant called Vanish? It makes you disappear and everybody wonders where the odor is coming from.

SE

Probably the reason that God made woman last was that he didn't want any advice while creating man.

SE

A man was notified by his psychiatrist, "If you don't pay your bill, I'm going to let you go crazy."

SE

A girdle is an elastic supplement to stern reality.

SE

March 2

Johnson & Johnson
U. S. Gypsum
Borg-Warner
Fairbanks Morse
Olivetti-Underwood
Bell Aerosystems

March 3

Commonwealth of Kentucky
City of Milwaukee

March 4

Proctor & Gamble
Highway Department
National Aeronautics and
Space Administration
Socony Mobil Oil

March 5

Timken Roller Bearing
West Virginia Pulp & Paper

March 8

Los Angeles Civil Service
Continental Grain Co.
Parke, Davis & Co.
Marine Engineering Lab.
Louis Allis Co.
Goodyear Tire & Rubber

March 9

Pullman Standard
Union Carbide Corp.
Westinghouse Electric Corp.
The Gass Co.
Lear Siegler
Pittsburg-Des Moines Steel
Goodyear International

March 10

Libby-Owens-Ford Glass
Ingersoll-Rand
Cargill Inc.
Republic Steel

March 11

Texas Inst.
Douglas Aircraft
Owens-Illinois

March 15

Ford Motor Co. (Summer)

The Challenges of the Future



*Challenge: simulation of activities under zero-gravity.
Experiment: establish neutral buoyancy for astronauts in unique underwater testing sequence.*

ENGINEERS & SCIENTISTS: The future? Man in space. General Dynamics | Astronautics offers you the challenges of helping to develop man's usefulness and support in this awesome environment of the future. The tasks are complex. The problems are many. The challenges are significant. As the space-oriented division of the great General Dynamics Corporation, Astronautics will meet them with the vigor and full range of resources that have characterized our past successes. Join our teams of experts in realizing man's destiny in space.

Scientific and technical opportunities exist at all degree levels in activities that include RESEARCH, DESIGN, DEVELOPMENT, TEST, COMPUTER PROGRAMMING, RELIABILITY, and ADMINISTRATION.

For General Dynamics | Astronautics career information, see your placement officer and watch for campus interview schedules, or write to Mr. B. L. Dobler, Chief of Professional Placement and Personnel, Dept. 130-90, General Dynamics | Astronautics, 6004 Kearny Villa Road, San Diego, California 92112. An Equal Opportunity Employer.

GENERAL DYNAMICS | ASTRONAUTICS 

We Will Visit Your Campus February 15, 16

Too busy to send letters to the folks? the parole officer? the creditors?

Penny I. Wainer has the perfect solution — an all-purpose form letter:

Dear

- Folks,
- To Whom It May Concern:
- Herman—
- Warden;
- Crossing Ahead — Go Slow!

Another quarter is here and already I feel

- Depressed.
- Horny.
- Like a schizo.
- With my hands.
- Broke.

From past experience I know that the only thing than can Really help me is a

- Good stiff shot of Bourbon.
- Signed check.
- Fix.
- Night away from the dorm.
- Few copies of my finals.

Maybe you can help me, huh? There's not too much happening lately. Oh, yes, last night

- There was a panty raid at the Dean of Women's house.
- I chugged a keg of beer.
- We drained Mirror Lake at 2 AM.
- We hung one of the deans in Effigy — a small town near Cols.
- The ROTC boys had a "book burning" bonfire.

Outside of that, it's pretty dead. Yesterday I met the cutest

- fox terrier.
- plum tree.
- minister, priest, rabbi (take your pick).
- atheist.
- cesspool cleaner.

We merely nodded, but I'm sure something will come of it. I'll keep you posted. Well, I guess I better close now. You see

- the beer is arriving.
- the orgy's about to begin.
- got to cram like hell for a midterm.
- I'm becoming terribly bored with the whole thing.
- my pinmate's tickling my neck.

So until the next letter, remember —

- to send a check.
- keep the Care Packages coming.
- send a check
- the Alamo.
- send a check.

- Love and kisses,
- Thanking you in advance,
- With deepest regrets,
- Yours for better living through anatomy,
- As usual,

- The little old wine maker
- Anxious
- The Mad Bomber
- The Midnight Skulker
- The Great Pumpkin

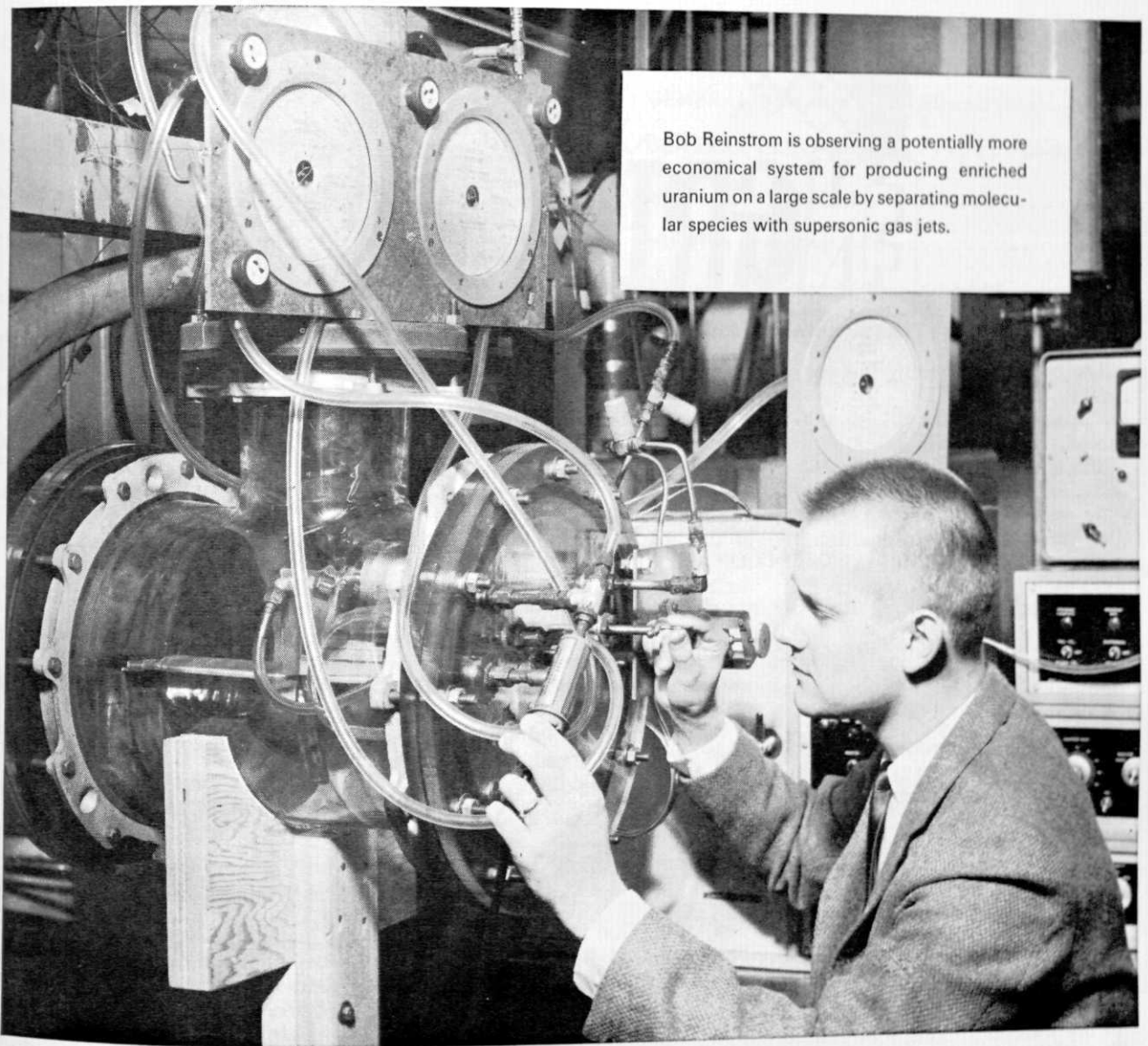

Bob Reinstrom is observing a potentially more economical system for producing enriched uranium on a large scale by separating molecular species with supersonic gas jets.

Young Engineers Find Opportunity at Allison

■ Bob Reinstrom came to Allison Division, General Motors, early in 1962 following his graduation from the University of Minnesota with a BS degree in Mechanical Engineering.

As a research engineer at Allison, he has been associated with the Nuclear Liquid Metal Cell Program, the MCR (Military Compact Reactor) Project, and the Energy Depot Project. In these assignments, he has contributed to these studies:

- 1—Analysis and design of heat transfer equipment to investigate boiling, condensing, and thermal cycling in closed liquid metal systems.
- 2—The steady-state parametric optimization and transient behavior analysis of nuclear reactor systems.
- 3—Thermodynamic analysis of open chemical processes.

Presently, Bob is doing graduate work in engineering at Purdue University-Indianapolis campus . . . one of

the many advantages of a job with Allison.

Allison's broad education and training programs offer unlimited opportunities to the young graduate engineer desiring education beyond the normal four or five years of college training.

If you're interested in knowing more about Allison's Graduate Study Program, see our interviewer when he visits your campus. Or, write now for your copy of Allison's brochure, explaining your opportunities for advancing your professional career at Allison. Send your request to: Allison Division, General Motors Corporation, Indianapolis, Indiana 46206, Att: Professional and Scientific Placement.

An equal opportunity employer

Allison **GM**
 THE ENERGY CONVERSION DIVISION OF
 GENERAL MOTORS, INDIANAPOLIS, INDIANA
 General Motors

ENGRINEERS

The boss was chasing his secretary as usual. "Let's go up to my apartment tonight," he suggested.

She answered, "I am very didactic and pithy in my refusal of your very derogatory vituperative, and vitrolic proposition."

"I don't get it."

"That's what I've been trying to tell you."

SE

The double-E major was explaining to his date about the psychiatric treatments he had been undergoing for a month. "The doctor's an idiot," he asserted. "He says I'm in love with my wristwatch."

"And, of course, you aren't," said the girl.

Holding the watch up to his ear and listening to it tick, the guy smiled and said, "I may be fond of my watch, but that's no reason to say I'm emotionally involved."

SE

"Oh, George," said the pretty young coed, "do you really love me as much as you say you do?"

"Of course I do," the boy vouched, "but my name is Henry."

"Drat," the coed said angrily. "I wish I'd stop thinking this was Tuesday night!"

SE

Two hillbillies were taking their first train ride, when they decided to try the soda pop in the vending machine at the station. Ike took his first swig just as the train was entering a tunnel.

"How is it Ike?" asked his companion.

"Don't drink it, Zeke," Ike warned. "I been struck blind."

A Protestant minister, a Catholic priest, and a Jewish rabbi were going fishing, but the motor on their boat died twenty feet from shore. The minister stood up, stepped casually out of the boat, and walked across the top of the water to the shore. Then the priest also left the boat, walking on the water to the shore. The rabbi looked at the two on the shore, took a deep breath, and stepped from the boat, sinking to the bottom in fifteen feet of water.

The priest turned to the minister and remarked, "I think we should have told him where the rocks were."

SE

When you get to heaven, you can tell God from the angels because God has a great big G on the front of His sweatshirt.

SE

A slightly plump friend of ours lost 105 pounds last month, yet he couldn't be more miserable. She was a gorgeous redhead.

SE

An inmate in the lunatic ward of a large hospital was trying to talk the doctor into believing that he was Napoleon.

"But who told you that you're Napoleon?" asked the doctor.

"God did!" asserted the lunatic.

"I did not!" roared a deep voice from the next bed.

SE

Freshman: If you'll go out with me just this once, I promise I won't try to kiss you, or get fresh, or anything like that.

Coed: You just talked yourself out of one great date.

After giving the young woman a thorough physical examination, the doctor asked her, "What is your husband's name?"

"I don't have a husband," was the reply.

"Your boyfriend then?"

"I don't have a boyfriend either."

The doctor crossed his office to a window facing East, raised the Venetian blinds, and looked outside.

"Why are you doing that?" the girl asked.

The doctor said, "My dear girl, a star rose in the East the last time this happened, and I don't want to miss it this time."

SE

It was the little old lady's seventieth birthday and she was beginning to fear everyone had forgotten her, when the Western Union man rang her doorbell. "Oh, joy, it must be a birthday telegram," chuckled the little woman, "Please sing it to me."

"Lady, I can't sing this," protested the bearer of the telegram.

"Pretty please," the lady persisted.

"No, lady no," was the reply.

"Look," asserted the little old lady, "if you don't sing that to me, I'm going to call up your company and complain!"

"Well, okay, lady," the messenger relented. "La-la-la-Your-son-is-dead."

SE

"Honey," whispered the cute little coed as she snuggled deeper into her boyfriend's arms, "don't you think it's about time we were getting married?"

"You know, I think you're right," he replied, yawning, "but who in the world would have us?"

THE ADVERTISER'S INDEX

Advertiser	Page	Advertiser	Page
AC, DIV. OF GENERAL MOTORS	21	GENERAL DYNAMICS (ASTRONAUTICS)	51
ALLIED CHEMICAL	47	GENERAL ELECTRIC CO.	Back Cover
ALLISON, DIV. OF GENERAL MOTORS	53	HAMILTON STANDARD	49
THE ASPHALT INSTITUTE	55	HUGHES AIRCRAFT CO.	35
A. T. & T.	31	IBM	8-9
BENDIX CORP.	13	INTERNATIONAL HARVESTER	23
BETHLEHEM STEEL	44	KODAK	Inside Back Cover
CORNING GLASS WORKS	25	MONSANTO	7
DEERE AND CO.	48	NATIONAL CASH REGISTER	4
DELCO RADIO	45	NAVAL ORDNANCE LABORATORY	1
DETROIT EDISON	41	OLIN - MATHIESON	2
DOUGLAS AIRCRAFT CO.	12	PRATT AND WHITNEY AIRCRAFT	28-29
DUPONT	17	RCA	12
FISHER GOVERNOR CO.	56	SYLVANIA	37
FORD MOTOR CO.	39	TIMKEN	5
GARRETT	16	U.S. RUBBER	33
		WESTINGHOUSE	Inside Front Cover

CIVIL ENGINEERS:

Prepare now for your future in highway engineering... get the facts on The Asphalt Institute's new computer-derived method for determining structural design of Asphalt pavements for roads and streets

Today, as more and more states turn to modern Deep-Strength* Asphalt pavement for their heavy-duty highways, county and local roads, there is a growing demand for engineers with a solid background in the fundamentals of Asphalt technology and construction.

Help to prepare yourself now for this challenging future by getting the latest information on the new Thickness Design Method developed by The Asphalt Institute. Based on extensive statistical evaluations performed on the IBM 1620 and the mammoth IBM 7090 computers, accurate procedures for determining road and street structural requirements have been developed.

All the facts on this new method are contained in The Asphalt Institute's Thickness Design manual (MS-1). This helpful manual and much other valuable information are included in the free student library on Asphalt construction and technology now offered by The Asphalt Institute. Write us today.

*Asphalt Surface on Asphalt Base

THE ASPHALT INSTITUTE
College Park, Maryland

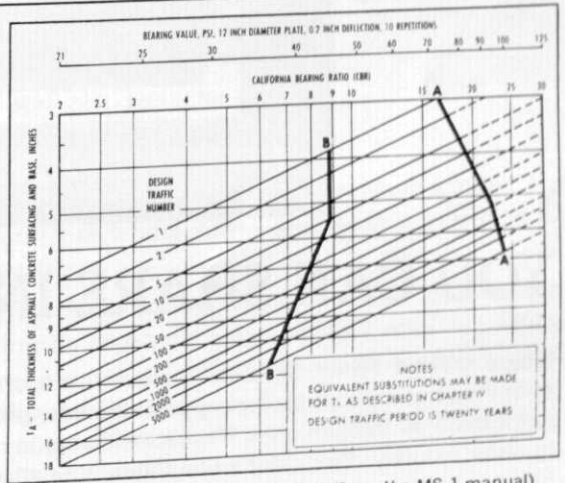

Thickness Design Charts like this (from the MS-1 manual) are used in this new computer-derived method. This chart enables the design engineer quickly to determine the over-all Asphalt pavement thickness required, based on projected traffic weight and known soil conditions.

THE ASPHALT INSTITUTE
College Park, Maryland

Please send me your free student library on Asphalt construction and technology, including full details on your new Thickness Design Method.

Name _____ Class _____
 School _____
 Address _____
 City _____ State _____



YOU CAN SHARE IN A GROWTH LIKE THIS

Whose growth? Fisher Governor Company, manufacturer of automatic controls for any and all fluids, gases or air that flow through pipe. We are the leader in our growing industry. Our sales have shown a relatively steady rise during the past decade (from 18-million to 41.5-million—a 130% increase in just ten years). See chart above. Our products—control valves, pressure regulators, liquid level controls and instruments—are key elements in industrial automation.

Location: Fisher is basically an "Engineering" company with 1,500 employees located in a pleasant Iowa community of 22,000. It's less than 10 minutes to the modern Fisher plant and engineering facilities from any home in Marshalltown. The community has an

outstanding cultural and educational environment.

Type of work: Fisher offers a rewarding challenge to the graduate engineer (BS and MS) who is interested in design and development, research and test, sales or manufacturing.

Advancement: Coupled with Fisher's policy to promote from within, advancement opportunities reflect a growing company within a growing industry.

If a growing company like ours appeals to you, consult your placement office or write directly to Mr. John Mullen, Employee Relations Manager, FISHER GOVERNOR COMPANY, Marshalltown, Iowa.

An Equal Opportunity Employer

If it flows through pipe, chances are it's controlled by



Spartan Engineer

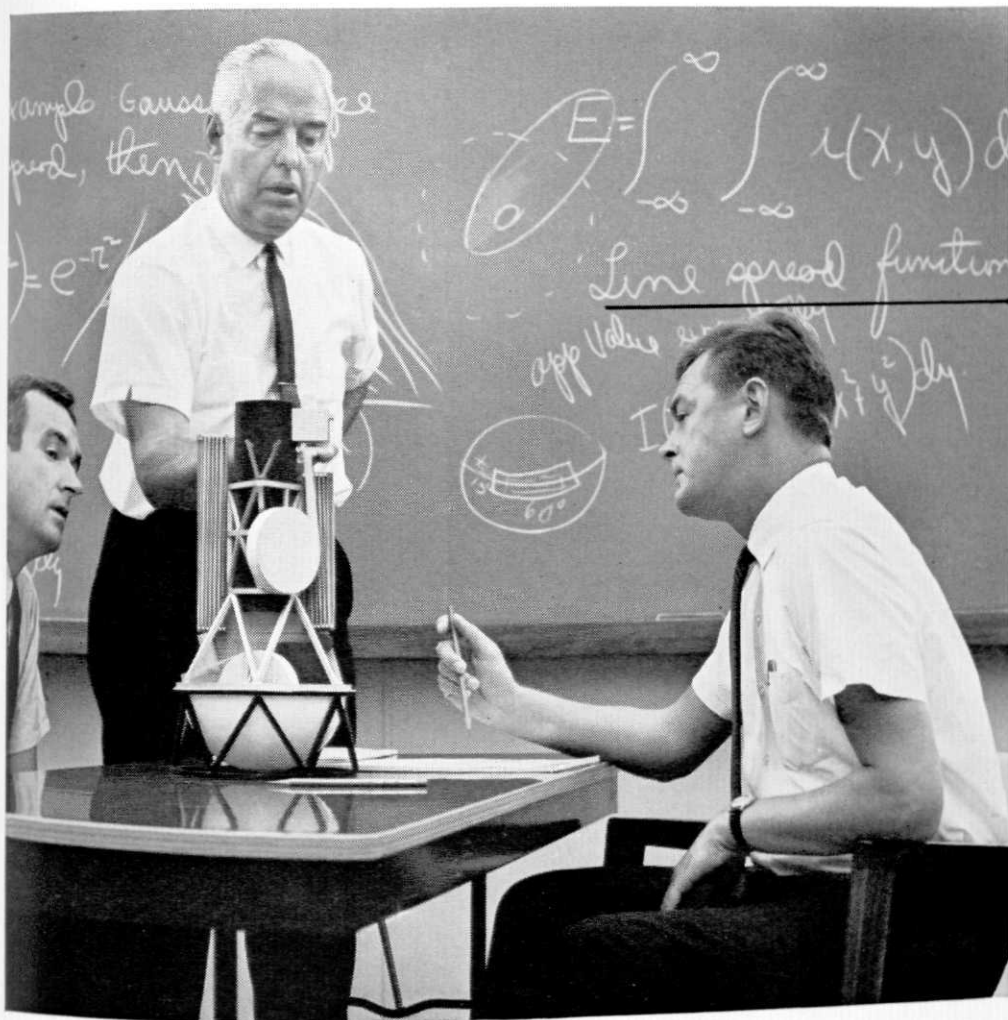

Some
M.E.s
are
going
to learn
what
this
means

The mechanical engineer who decides to join forces with us upon completion of his formal education will discover soon enough that the biggest part of his education is still ahead of him. This cliché can be interpreted two ways.

The literal way—"Line spread function" mathematizes certain aspects of image structure in optical theory. Very few mechanical engineers shelter behind academic ivy long enough to get that deep into other men's games. If, for example, we need mechanical engineers capable of communicating with our optical physicists for a common purpose—and we have such purposes in our little-known but heavy aerospace commitments—we had better provide the right fertilizer for ivy ourselves. So we do. Some of the more sophisticated current ideas on what constitutes

engineering have strong partisans among the men from whose ranks a newcomer can pick his boss here.

The hard-boiled way—The nice part about being an engineer here is that a man can find a level of sophistication to suit his interests even without risking the shifting sands of international policy. We are plainly, frankly, proudly, and gloriously commercial. We need men to whom to teach the technical subtleties of making money from satisfying the everyday needs of people and of business. When done properly, it can be as challenging to the intellect as the work of the engineer across the road who gets the same signature on his paycheck for ideas on palpatting the moon.

Drop us a line.

EASTMAN KODAK COMPANY,

Business and Technical Personnel Department, Rochester, N.Y. 14650
An equal-opportunity employer offering a choice of three communities:
Rochester, N.Y., Kingsport, Tenn., and Longview, Tex.

Kodak

Advancement in a Big Company: How it Works

An Interview with General Electric's C. K. Rieger, Vice President and Group Executive, Electric Utility Group



C. K. Rieger

■ Charles K. Rieger joined General Electric's Technical Marketing Program after earning a BSEE at the University of Missouri in 1936. Following sales engineering assignments in motor, defense and home laundry operations, he became manager of the Heating Device and Fan Division in 1947. Other Consumer-industry management positions followed. In 1953 he was elected a vice president, one of the youngest men ever named a Company officer. Mr. Rieger became Vice President, Marketing Services in 1959 and was appointed to his present position in 1961. He is responsible for all the operations of some six divisions composed of 23 product operations oriented primarily toward the Electric Utility market.

Q. How can I be sure of getting the recognition I feel I'm capable of earning in a big company like G.E.?

A. We learned long ago we couldn't afford to let capable people get lost. That was one of the reasons why G.E. was decentralized into more than a hundred autonomous operating departments. These operations develop, engineer, manufacture and market products much as if they were inde-

pendent companies. Since each department is responsible for its own success, each man's share of authority and responsibility is pinpointed. Believe me, outstanding performance is recognized, and rewarded.

Q. Can you tell me what the "promotional ladder" is at General Electric?

A. We regard each man individually. Whether you join us on a training program or are placed in a specific position opening, you'll first have to prove your ability to handle a job. Once you've done that, you'll be given more responsibility, more difficult projects—work that's important to the success of your organization and your personal development. Your ability will create a "promotional ladder" of your own.

Q. Will my development be confined to whatever department I start in?

A. Not at all! Here's where "big company" scope works to broaden your career outlook. Industry, and General Electric particularly, is constantly changing—adapting to market the fruits of research, reorganizing to maintain proper alignment with our customers, creating new operations to handle large projects. All this represents opportunity beyond the limits of any single department.

Q. Yes, but just how often do these opportunities arise?

A. To give you some idea, 25 percent of G-E's gross sales last year came from products that were unknown only five or ten years ago. These new products range from electric tooth brushes and silicone rubber compounds to atomic reactors and interplanetary space probes. This changing Company needs men with ambition and energy and talent who aren't afraid of a big job—who welcome the challenge of helping to start new businesses like these. Demonstrate your ability—whether to handle complex technical problems or to manage people, and you won't have long to wait for opportunities to fit your needs.

Q. How does General Electric help me prepare myself for advancement opportunity?

A. Programs in Engineering, Manufacturing or Technical Marketing give you valuable on-the-job training. We have Company-conducted courses to improve your professional ability no matter where you begin. Under Tuition Refund or Advanced Degree Programs you can continue your formal education. Throughout your career with General Electric you'll receive frequent appraisals to help your self-development. Your advancement will be largely up to you.

FOR MORE INFORMATION on careers for engineers and scientists at General Electric, write Personalized Career Planning, General Electric, Section 699-11, Schenectady, N. Y. 12305

GENERAL  ELECTRIC

An Equal Opportunity Employer