

# Spartan Engineer

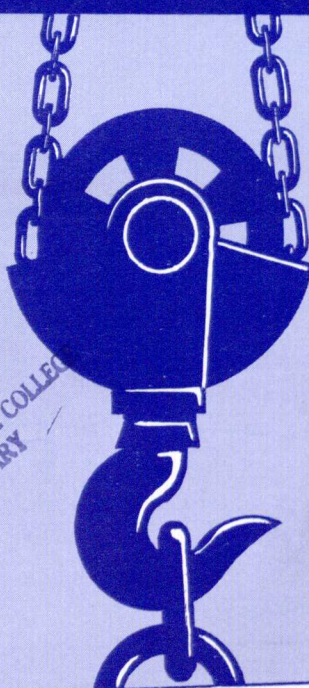

PERIODICAL  
APR 7 1955  
MICHIGAN STATE COLLEGE  
LIBRARY



**Cylinder from Mars**

**Metal from the Sea . . . Magnesium**

**Construction of a Generator-Type  
Dynamometer**

**The Transistor**

**A Machine Designer's Protest of a Protest**

**Robert L. Land, Jr., Class of '51,**  
speaks from experience when he says,

**U.S. Steel offers thorough training . . .  
exposes the graduate engineer to many  
interesting phases of the steel industry**



**R**OBERT L. LAND, JR., graduated with a B.S. in Chemical Engineering in February 1951. He had previously been interviewed by U.S. Steel college recruitment representatives and had been offered a job. He began working in the Coke Plant at the Gary, Indiana Works of U.S. Steel immediately after graduation.

After extensive training and several promotions, Bob was made General Heater Foreman on November 1, 1954. This exceedingly important job makes him responsible for the proper heating and the quality of all coke produced at the Gary Works—the second largest coke plant in the world—with 16 batteries of coke ovens producing 15,000 tons daily. He has a crew of 60 and 8 foremen working under him.

Bob feels that U.S. Steel really gets the young graduate engineer off to a good start

with a well-planned and complete training program. He says, "U.S. Steel offers the graduate engineer an excellent chance to work in a number of different fields."

This enables the graduate who has not decided on his exact field to look around the big steel industry from within and to find the type of work that suits him best. After a man is given the chance to really find himself and has been adequately trained, "U.S. Steel offers security and an unlimited possibility of advancement pro-

viding the engineer shows initiative and the willingness to work."

If you are interested in a challenging and rewarding career with United States Steel and feel that you can qualify, you can obtain further information from your college placement director. Or we will gladly send you our informative booklet, "Paths of Opportunity," upon request. Just write to United States Steel Corporation, Personnel Division, Room 1622, 525 William Penn Place, Pittsburgh 30, Pa.

**SEE THE UNITED STATES STEEL HOUR.** It's a full-hour TV program presented every other week by United States Steel. Consult your local newspaper for time and station.



**UNITED STATES STEEL**

AMERICAN BRIDGE . . AMERICAN STEEL & WIRE and CYCLONE FENCE . . COLUMBIA-GENEVA STEEL . . CONSOLIDATED WESTERN STEEL . . GERRARD STEEL STRAPPING . . NATIONAL TUBE OIL WELL SUPPLY . . TENNESSEE COAL & IRON . . UNITED STATES STEEL PRODUCTS . . UNITED STATES STEEL SUPPLY . . Divisions of UNITED STATES STEEL CORPORATION, PITTSBURGH  
UNITED STATES STEEL HOMES, INC. • UNION SUPPLY COMPANY • UNITED STATES STEEL EXPORT COMPANY • UNIVERSAL ATLAS CEMENT COMPANY



*and building*  
**Looking ahead with Detroit Edison**

Important new addition to the engineering facilities of Detroit Edison is this huge System Analog and Network Computer, bringing new speed, accuracy and convenience to solving the problems of providing better power systems, both for today and for tomorrow.

Designed and built by Detroit Edison engineers, this unique four-ton machine reproduces in miniature the company's power system, and can be varied to simulate other power systems as well. The effect of any

combination of generators, transformers, lines, cables and other equipment, and of any variations in components within the system, can be determined in a fraction of the time required by conventional methods.

The System Analog and Network Computer, along with other advanced electronic equipment, such as the digital computer, serves Detroit Edison engineers in a variety of fields, including research, system operation, and production, planning, project and design engineering. . . . Such ad-

vanced facilities, combined with the steadily rising demands for electrical power in Detroit and Southeastern Michigan, enable Detroit Edison to offer young engineers an outstanding opportunity and challenge to build for their own futures.

*For the full story of career opportunities at Detroit Edison, simply call or write for a free copy of this new booklet, "Detroit Edison Engineering."*

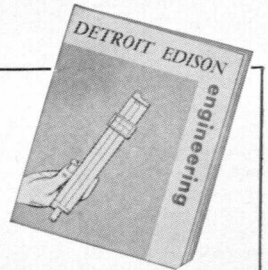

**THE DETROIT EDISON COMPANY**

2000 Second Avenue  
 Detroit 26, Michigan



**"POWER OFF!"** Test operations are directed from this central control room, where special measuring instruments greatly speed up the collection of pump performance data. That's one way Worthington products are made more reliable by using . . .

## ...the world's most versatile hydraulic proving ground

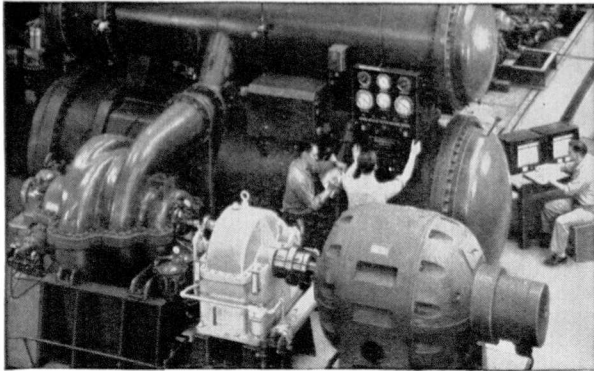

**COMPREHENSIVE TESTS** are run on a Worthington centrifugal refrigeration unit (lower left) now in service as one of the Arabian American Oil Company's central air conditioning units in Dhahran, Saudi Arabia.

When you make pumping equipment that has to stand up and deliver year after year anywhere in the world, you've got to be sure it will perform as specified.

That's why we built one of the world's largest hydraulic test stands at our plant in Harrison, New Jersey. Here, over a half-acre "lake," we can check the performance of anything from a fractional horsepower unit to pumps handling over 100,000 gallons a minute. When you realize there are thousands of sizes and types of centrifugal pumps alone, you get an idea of the versatility we had to build into our proving-ground.

Naturally, our new test equipment is a big help to our research engineers, as well as our customers. Now they get performance data on products quickly and accurately. Using it, we can save months, even years, in developing new Worthington fluid and air-handling devices — equipment for which this company has been famous for over a century. For the complete story of how you can fit into the Worthington picture, write F. F. Thompson, Mgr., Personnel & Training, Worthington Corporation, Harrison, N. J.

4.25A

See the Worthington representative when he visits your campus

# WORTHINGTON



When you're thinking of a good job—think high—think Worthington

AIR CONDITIONING AND REFRIGERATION • COMPRESSORS • CONSTRUCTION EQUIPMENT • ENGINES • DEAERATORS • INDUSTRIAL MIXERS  
LIQUID METERS • MECHANICAL POWER TRANSMISSION • PUMPS • STEAM CONDENSERS • STEAM-JET EJECTORS • STEAM TURBINES • WELDING POSITIONERS

Editor  
RAY STEINBACH

Business Manager  
BILL BARTLEY

Associate Editor  
ALICE JACOBSON

Assistant Editors  
HARLOW NELSON  
EMORY GEISZ

Photo Editor  
BOB BRANDON

Feature Editor  
EUGENE SPELLER

News Editor  
BOB STOCKING

Assistant Business Manager  
JOHN ROOD

Advertising Manager  
ART SIPPOLA

Promotion Manager  
CHARLES PUMA

Circulation Manager  
JENNY WILSON

Staff

JO GRAHAM  
JIM JOHNSTON  
SHIRLEY PRIKASKY  
DAVE MITCHELL  
BOB FREDERICKS  
JAMES WILSON  
TOM AYRES

Advisors  
W. E. LIBBY  
PAUL G. GRAY  
D. D. McGRADY

# *Spartan Engineer*

of michigan state college

## ARTICLES

- 11 Cylinder from Mars
- 15 Metal from the Sea . . . Magnesium
- 19 Construction of a Generator-Type Dynamometer
- 23 The Transistor
- 26 A Machine Designer's Protest of a Protest

## FEATURES

- 8 Clubs and Societies
- 12 Engineering Alumni
- 17 New Developments
- 48 Crossword for Engineers

Cover Design by:  
EMORY GEISZ

Published four times yearly by the students of the SCHOOL OF ENGINEERING, MICHIGAN STATE COLLEGE, East Lansing, Michigan. The office is on the third floor of the Union Building, Phone ED 2-1511, Extension 251. Entered as second class matter at the Post Office in Lansing, Michigan, under the act of March 3, 1879.

Address Mail to: P. O. Box 468, East Lansing, Michigan

Publishers representative  
Littell-Murray-Barnhill, Inc.  
101 Park Avenue, New York  
605 W. Michigan Avenue, Chicago

Subscription rate by mail \$1.00 per year.  
Single copies 25 cents.

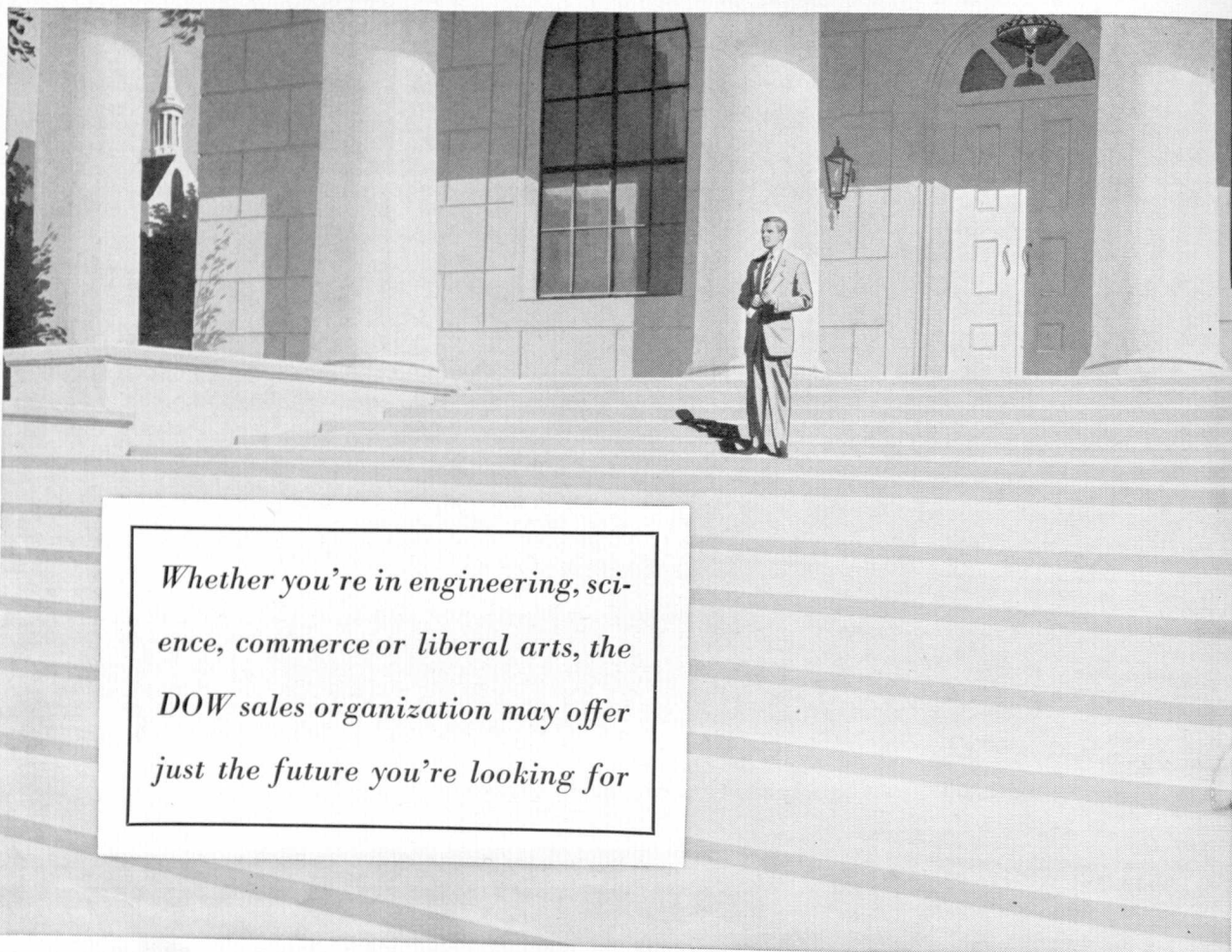

*Whether you're in engineering, science, commerce or liberal arts, the DOW sales organization may offer just the future you're looking for*

# What About Your Future?

Your opportunities for advancement are excellent because Dow is growing—continually building new plants, developing new production operations—adding new products, opening new markets.

Dow fits you for the job with a comprehensive training course which explains company organization, policy, finance, research, production, technical service and sales methods.

You'll find that Dow is a friendly company. You'll discover that promotions are usually from within, from Dow's own staff. Seldom is an outsider considered for a top job at Dow. Moreover, you'll find a highly developed spirit of cooperation between men and departments.

At Dow, your future can be more secure because of Dow's diversification of products serving many different markets

—a real advantage if business slows—and certain to multiply opportunities as business expands. Also at Dow—group insurance, pension plans and employee stock purchase plans have been a tradition.

If you or any of your friends majoring in other fields of study who have had pre-engineering or one year or more of college chemistry are interested in finding out more about a future at Dow, write to Dow's Technical Employment Department today.



*Dow's Booklet, "Opportunities with The Dow Chemical Company," especially written for those about to enter the chemical profession, is available free, upon request. Write THE DOW CHEMICAL COMPANY, Technical Employment, Midland, Michigan, or Freeport, Texas.*

*you can depend on DOW CHEMICALS*



## FIVE YEAR ENGINEERING CURRICULUM

Did you have a chance to take those electives which you wanted? Seventeen to nineteen credits per term of required subjects doesn't leave much time for any other courses.

This is the situation which holds true throughout the entire school of engineering. The reason for this is simply that any person who hopes to be a successful engineer must have a certain amount of knowledge before he starts to work. The only way to obtain this knowledge is through the many required courses.

This leaves only one answer to the question of how to get in those desired electives. The five year engineering curriculum is that answer.

With the same requirements for graduation as now exist in the school of engineering, the student on the five year plan could take two credits less per term and still have time for over twenty credits of electives. This would enable the engineering student to gain some knowledge in other fields, such as psychology or certain parts of journalism such as business letter writing.

For some people the extra year of school might appear to cause financial hardships but with the lighter load of school work there would be more time for a part time job. Such a job could provide not only the needed funds but, also a certain amount of practical experience which could easily be very valuable when starting a permanent job after graduation.

With the present trend towards the five year plan it should be in use within three or four years.

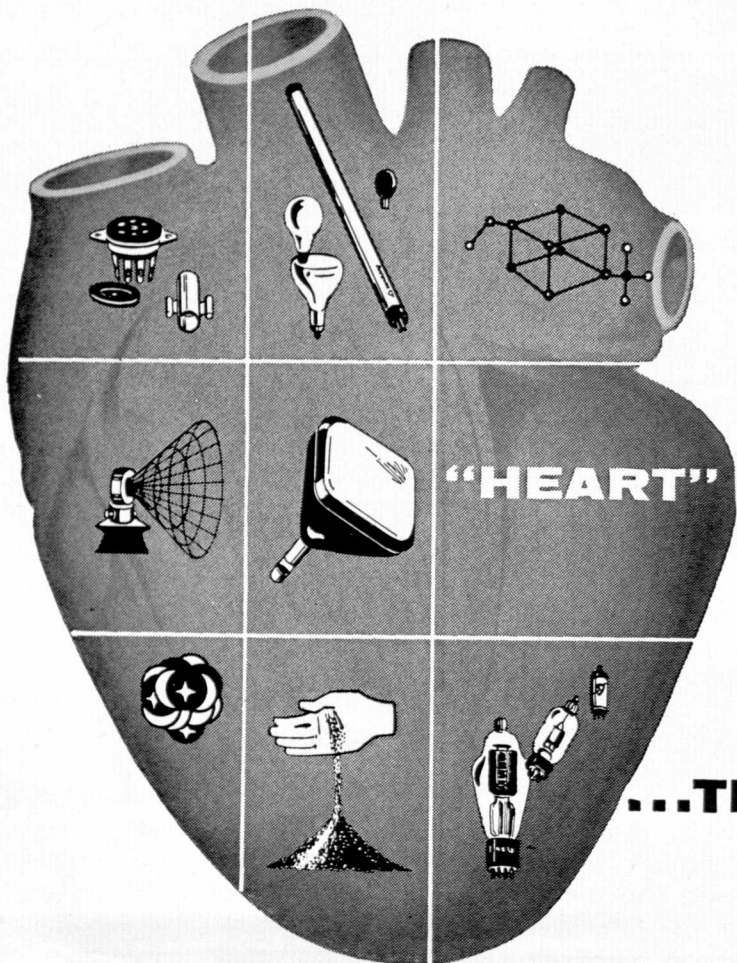

**WHAT  
SYLVANIA'S  
"HEART" BUSINESS  
MEANS  
TO YOU  
...THE ENGINEER**

Supplying vital components and parts that are the "heart" of hundreds of industrial and consumer products of other manufacturers...that's Sylvania's "heart" business.

It's an *extra* stability factor that safeguards your long-range career plans!

When you combine this fact with the company's leading position as a manufacturer of such Sylvania consumer products as: television sets, radios, fluorescent, incandescent and photoflash lamps, you can readily see that Sylvania is a company with exceptional diversity. That's why Sylvania can offer you the security you need for professional success.

In the brief 53 years since its founding, Sylvania's dedication to young, aggressive management (the average top executive age is only 45), has meant expansion into an organization of 45 plants, 12

laboratories in 11 states, with over 24,000 employees.

To keep pace with the demand for Sylvania's products, our engineering staff has more than doubled in the past 6 years. 1954 saw the addition of 2 new laboratories, the completion of a new television manufacturing plant, a TV picture tube plant, and the start of a new incandescent lamp plant.

Diversity . . . stability . . . growth — these are the foundations that make Sylvania an excellent place to build your career in engineering.

For detailed information on Sylvania's program for graduating engineers, see your College Placement Office. Or send for our comprehensive booklet, "Today and Tomorrow With Sylvania" by writing to Supervisor of Technical Employment.

# SYLVANIA

Sylvania Electric Products Inc.



1740 Broadway, New York 19, N. Y.

LIGHTING • RADIO • ELECTRONICS • TELEVISION • ATOMIC ENERGY



# THE ALUMINUM INDUSTRY WAS BORN ON SMALLMAN STREET

▼ In 1888, the aluminum industry consisted of one company—located in an unimpressive little building on the east side of Pittsburgh. It was called The Pittsburgh Reduction Company. The men of this company had real engineering abilities and viewed the work to be done with an imagining eye. But they were much more than that. They were pioneers . . . leaders . . . men of vision.

A lot has happened since 1888. The country . . . the company . . . and the industry have grown up. Ten new territories have become states, for one thing. The total industry now employs more than 1,000,000 people—and the little outfit on Smallman Street? Well, it's a lot bigger, too—and the name has been changed to Alcoa. ALUMINUM COMPANY OF AMERICA . . . but it's still the leader—still the place for engineering "firsts".

As you prepare to trade textbooks for a position in industry, consider the advantages of joining a dynamic company like Alcoa—for real job stability and pleasant working conditions—where good men move up fast through their association with the recognized leaders in the aluminum industry.

Alcoa's new  
aluminum office  
building

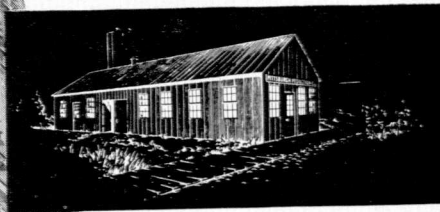
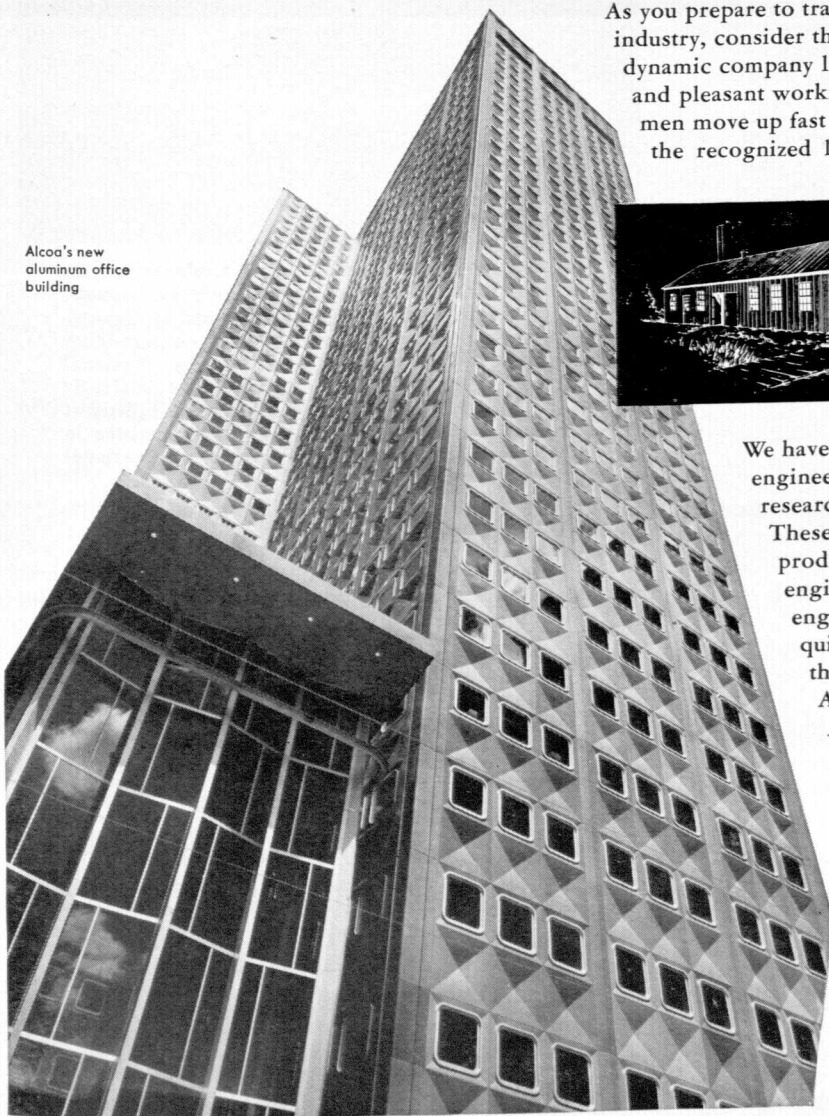

We have fine positions for college graduate engineers—in our plants, sales offices and research laboratories from coast to coast. These are positions of responsibility in production supervision, plant and design engineering, industrial research or sales engineering. Right now it may be quicker than you think from a seat in the classroom to your career with Alcoa. Why not find out?

Your Placement Director will be glad to make an appointment for you with our personnel representative. Or just send us an application yourself. ALUMINUM COMPANY OF AMERICA, 1825 Alcoa Bldg., Pittsburgh 19, Pa.

**ALCOA**   
**ALUMINUM**  
ALUMINUM COMPANY OF AMERICA

# CLUBS AND SOCIETIES

by Shirley Prikasky

## Tau Beta Pi

In a formal ceremony held in 403 Olds Hall on Feb. 24, Tau Beta Pi initiated 26 men to membership. To be eligible for membership in Tau Beta Pi, a student must rank scholastically in the upper  $\frac{1}{8}$  of the junior engineering class, or the upper  $\frac{1}{5}$  of the senior engineering class. The following men were initiated:

### Professional Members:

Mr. Harry L. Conrad, of the Christman Co. of Lansing.

Mr. Arthur W. Farrall, Head of the Department of Agricultural Engineering at Michigan State College.

### Undergraduate Members:

Frank J. Alfonso	Wayne C. Liddle
Robert A. Brandon	Thomas J. Linton
Edwin B. Champagne	Carl F. Lutz
Joseph A. Cieslewicz	Jack S. Macauley
George E. Clute	John J. Mikoliczeak
John L. Davies	Robert R. Murrell
Samuel L. DeLeeuw	Donald R. Musson
Lloyd J. Hassencahl	Thomas M. Payette
Lawrie W. Honens	John K. Sauter
James W. Jennings	Brant A. Short
Julian Kateley, Jr.	Rennie J. Swope
Kay V. Lask	Marvin L. VanDerPloeg

Dean John D. Ryder addressed the local members of Tau Beta Pi at a Banquet held in Kellogg Center immediately following the formal initiation. The subject of the talk was "Science in Engineering."

## Engineering Council

The members of the Engineering Council are now setting up the annual Engineering Exposition which is scheduled for May 12, 13, and 14. It will be similar to the one held last year. The Exposition is mainly directed toward interesting high school students in the many engineering fields. Also, there are spectacular science exhibits which should attract the general public.

The Exposition will include many different activities. There will be an engineering symposia, a feature of the centennial year and the first to be held at State. It will be a series of conferences where eminent leaders in engineering will meet to discuss problems and developments in engineering. Being a part of the Engineering Exposition, it will be held during the week of May 12.

Starting at the beginning of Spring term, the council will sponsor a series of eight TV shows devoted to engineering. A different engineering society takes over each show and presents informative material from its field. Students interested in having a part in these programs are asked to contact Arnold Morse.



Ralph Redman, senior mechanical engineering student, is presented a bronze medal by Prof. Leonard Price, head of the Mechanical Engineering Department. Ralph was chosen to be the outstanding engineering student at MSC by the National Society of Mechanical Engineers. The medal is being awarded to the best engineering student at each school where there is a student chapter in commemoration of the founding of the national chapter 75 years ago.

Exhibits in the Engineering Exposition will be of three types: Industrial, those from the engineering societies, and student originated.

Among the Industrial exhibits last year were the RCA exhibits of transistors and ultra-high frequency radio transmission. The transmitter was about the size of a cigarette pack which is made possible by the use of transistors. Its maximum range was about three city blocks. The GE special program showed an egg frying on a cold plate, radio waves interrupted by the hand, chemical cocktails, and synthetic rubber made before your eyes. Olds displayed the body of an auto without paint or seats to show its construction. Many big trucks, bull dozers, and concrete mixers attracted interest. There was a Diesel locomotive and a caboose on exhibit. And of particplar interest to the farmers in this vicinity was the agricultural display by the college. It included scale model farms, rooms from model homes, and other phases of farm life. The exhibits this year will be very similar to those of last year.

There will be exhibits entered by the separate engineering societies and individual students. An engraved plaque will be awarded for the best society exhibit and student exhibit. Last year a plaque was won by the American Institute of Chemical Engineers. The student exhibit was won by Bill Bartley for his binaural sound display.

A highlight of Exposition week will be the Micro-midget auto race. It always includes feverish last minute work which seems to be unavoidable but is a lot of fun. The race will run on the morning and afternoon of Saturday, May 14. The course is Circle Drive and there will be four laps. Many engineering societies will be building cars for this race.

---

## Eta Kappa Nu

If you were in the E.E. building and noticed several junior and senior E.E. students running around flashing lights from a large button on their coats, don't be alarmed. It was just the Eta Kappa Nu pledges gathering signatures from the actives or faculty members. At 4:30 p.m. on Feb. 17, eleven junior and senior E.E. students were initiated into Eta Kappa Nu. Along with this group of students the organization was proud to be able to induct as a professional member Mr. Claud R. Erickson, a noted engineer from the Lansing area, and a graduate of MSC. Beside being an outstanding engineer, Mr. Erickson is prominent in alumni affairs at Michigan State.

The project that the pledges carried out this term was to clean out and inventory one of the store rooms on the fifth floor of the E.E. building. Some of the things found there were not even known about by the faculty. That goes to show you that a little house-cleaning can bring startling results.

A family night for the members and the E.E. faculty was held March 4. The program boasted circle and square dancing, skits by both students and faculty, and refreshments.

---

## ASCE

At each meeting the American Society of Civil Engineers try to have a speaker in to tell the prospects and advantages of his phase of civil engineering. Speakers so far this term include: John Patriarche, East Lansing City Manager; Mr. Koons, Field Secretary for Associated General Contractors; and Mr. Pierce, State Sanitation Department.

Last fall term ASCE held its first annual Student-Alumni Civil Engineering Banquet. It proved to be very successful. Mr. John Meyers of the State Highway Department gave a very interesting talk on "Aerial Photography and the Modern Engineer." ASCE is looking forward to many more annual student-alumni banquets.

The student chapter is making plans for the forthcoming North Central Conference which they are hosting. The conference is to be held March 30, 31, and April 1, at Kellogg Center. The group is composed of 13 colleges and universities from Ohio and Michigan. The conference is being built around highways and transportation. Speakers are scheduled who are experts in this area.

Future plans include: a joint banquet with the Michigan section of ASCE and a field trip; and Abram's Aerial Survey, in Lansing.

---

## SAE

The Society of Automotive Engineers has an active program for the '54-'55 season with many interesting technical meetings and their ever popular film presentations.

After the first meetings in the fall dedicated to the nomination and election of officers, accompanied by film presentations; their first technical talk was delivered by Mr. C. W. Lincoln, Chief Engineer of the Saginaw Steering Gear Division of G.M. He delivered a fine talk on the development, fundamentals and details of power steering.

Another one of the informative technical meetings was devoted to aluminum applications in the automotive industry given by Mr. James M. Smith of the Engine Development Division of the Aluminum Company of America. Mr. Smith informed the group of the many beneficial uses of aluminum and how they were developed and tested. He also had many sample parts on display.

In future meetings, Mr. Ben D. Mills of the newly formed Continental Division of Ford Motor Company will talk on America's newest luxury car in a speech entitled, "The Continental Concept." Also, on a tentative schedule is "Disc Braces," "Suspension Systems," and "Engineering in the Sports Car Field."

One of the group's extra activities this spring will be the construction of a new car to uphold last year's victory in the Engineering Exposition race.

Visitors are always welcome to the meetings and the popular film presentations which are sandwiched between technical meetings.

---

## ASM

Members of the American Society for Metals had a very prominent speaker at their January 18 meeting. He was Mr. E. E. Thum, editor of *Metal Progress*. He presented a historical review of the last decade's progress in the field of metallurgy.

This organization is planning to have many interesting speakers at their future meetings. The next one is going to be a representative from the American Can Company. His topic will be controlled atmospheres in relation to heat treatment of metal products. All engineers are invited to hear these speakers, especially since these talks overlap into many different engineering fields.

---

## ASME

The American Society of Mechanical Engineers has the following officers this year: Chairman—Jim Cobb; Vice Chairman—Joe Cieslewicz; Secretary—Roy Cole; and Treasurer—Rod Miller. It has built up a membership of 77 students. Any student enrolled in a course which leads to a degree in any phase of engineering may join the society until March 10.

The society has one field trip each term. Last term the members visited the Goodyear Tire and Rubber

(Continued on page 30)

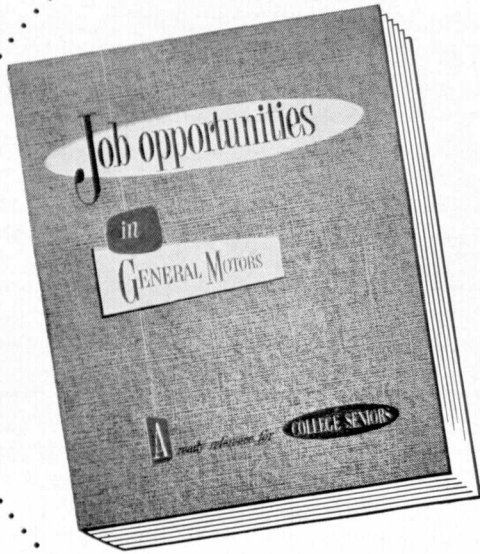

# **THE NEW GM GUIDANCE MANUAL**

*“Must” Reading for Young Engineers*

It's handsome, hefty and helpful—and you can probably borrow a copy at your school library or placement office.

Just ask for “Job Opportunities in General Motors.”

You'll find page after page of down-to-earth information about General Motors, the way we operate, the kind of young engineers we seek, and why so many of them enjoy rewarding careers with us.

Each GM division describes its products, the locations of its plants, the opportunities that are open, and the training programs offered to college graduates.

It's 136 pages, 8½" x 11", in color. In fact, it's the next best thing to actually paying us a personal visit—and we have a strong suspicion you'll want to find out more about careers with GM after reading this handbook.

If so, we suggest you arrange an interview with our GM College Representative, or write us directly.

#### **GM POSITIONS NOW AVAILABLE IN THESE FIELDS:**

ACCOUNTING • FINANCE • SALES • PRODUCTION SUPERVISION  
MECHANICAL ENGINEERING • ELECTRICAL ENGINEERING  
METALLURGICAL ENGINEERING • INDUSTRIAL ENGINEERING  
CHEMICAL ENGINEERING

## **GENERAL MOTORS**

*Personnel Staff, Detroit 2, Michigan*

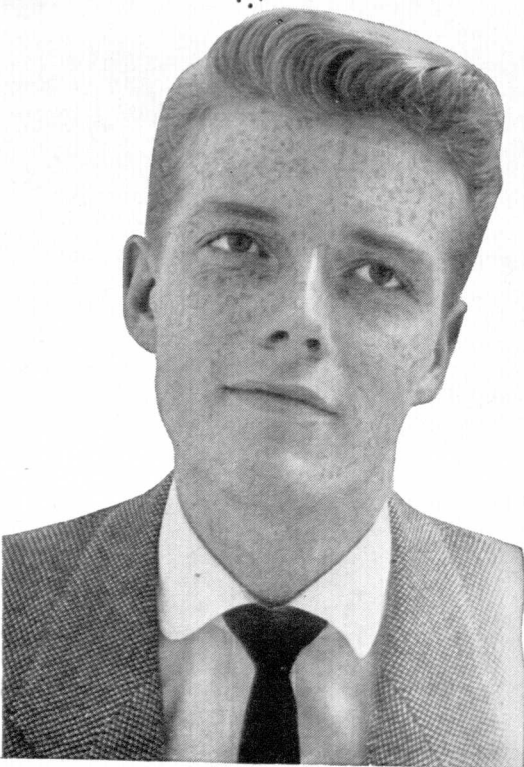

*"Someday you will understand that there is only one formula needed to understand the entire workings of the universe."*

## CYLINDER FROM MARS



by Diane Barrett, Jrn. '57

**S**INCE I am the oldest graduate of MSC, or MAC I should say, I have been asked to write an article on some of my experiences to commemorate the Centennial. I guess the editors thought it would have some sort of human interest angle. My most memorable experience occurred when I was a sophomore, and it was especially unusual. I've never related it to anyone before; in fact, after everyone reads it, I'll probably have to mortgage my home and move to the arctic.

It was Wednesday, February 12, and a bitter cold day much like the weather we have been having lately. Since girls weren't as welcome at MAC as they are these days, I was spending my leisure time studying in the library. Evidently my English literature instructor found more exhilaration in Shakespeare's rhetoric than I did, but I was dutifully fulfilling a requirement to read the soliloquy from Hamlet.

At the same time there was a bitter struggle going on in the back of my mind between my conscience and my inner desire to keep warm, but my conscience finally won out; so, I picked up my Lit. and hygiene books and headed for the campus police. I had incurred a fine while cycling on the sidewalk.

By the time I got past Sparty down where the Dem Hall and Jenison are now (then they were just a glint in the administration's eye) every bone and muscle in my body was frozen and aching. All of a sudden I heard a startling noise above me, and I looked up to see a cylindrical shaped object with a lightning exhaust come shooting out of the sky and land on the field. I was a bit shaken, yet drawn by curiosity I walked over to it. At the same time the inhabitants began to emerge. They were different, but physically not much larger than we are.

Obviously they didn't detect my surprise at seeing them, but like gentlemen immediately introduced themselves. The first one spoke, "I am Colonel Marxpwqm, and this is Martypll, Marsfkh, Marppmny, and Marjmcvn." As each was introduced, he bowed deeply. The pronunciation of their names was impos-

sible for me, because they had no vowels ("a" wasn't a vowel in those days), yet when the colonel said them, there was a rhythm and cadence. The colonel then explained, "We are an auxiliary unit which patrols the solar system to see that all is kept in order,"

He asked if I would like to step inside the cylinder—he promised not to fly away with me. I went inside. Never have I seen anything so fantastic.

There was a large column in the center of the main room, and set in it was a large glass with a ghost-like shape floating around in it. Martypll said, "This is Super-Radar. I'm sure someday people on the earth will find it very advantageous, that is, if they don't use it to their disadvantage first."

The next room we entered looked like a physician's office, very clean and white with bottles of medicine on the shelves. I was mistaken, however, for it was their bar. I suppose they did enjoy a few earthly pleasures. There was a lone man here whom I didn't recognize. The colonel said, "This is our chauffeur, Pluto, from the planet of the same name."

After I had seen the complete ship, we returned to the main room where I asked them many questions. The colonel promptly answered, "Mars is our home, and that's why all our names begin with the letters MAR." They didn't have any of the characteristics of the skinny little red-eyed men we see nowadays in cartoons, but they stood as straight as sentinels on duty. Their dress wasn't like Captain Video, rather it was a very conservative dark blue.

Marsfkh, who had been silent until then, quickly volunteered to tell me all the vital information about his home. "It is 141,540,143.723 miles from the sun around which it revolves, and we are fourth in distance from it, as compared to the other planets in the solar system. The velocity is 15.5103 miles per second, and it has a diameter of 4,191.76 miles. It requires 1.88 years to complete one revolution. Our seasons are twice as long as your which makes a very favorable environment most of the year. The year has 687 days, each day being only 24 hours, 37 minutes, and 22.67 seconds. We have two moons, Phobos and Deimos."

(Continued on page 35)

# ENGINEERING ALUMNI

by Agnes McCann, School of Engineering

Opening mail in the office of the Dean of Engineering is always a pleasure because so many of our alumni write us such interesting letters. There is only one thing better—a personal call.

Announcement was received recently of the promotion of Lewis J. Patterson, C.E. '39, to the position of Plant Manager of the Calcite Plant of Michigan Limestone Division of the U. S. Steel Corporation at Rogers City, Michigan. Pat has been with the company since he graduated, except for the time spent in army during World War II. He and Marian are the proud parents of a family of four—two girls and two boys.

George Robbins, C.E. '52, is also at Michigan Limestone where he is Plant Engineer. He, Betty, and son David reside at 296 Lake St., Rogers City.

Duane Burton, Ch.E. '39, was a recent visitor. He is with Boeing Aircraft and lives at 17043 Tenth Ave., N.W., Seattle 77, Washington. He reports that the following engineers are with Boeing: Vernon H. Donaldson, C.E. '53; John E. Long, M.E. '51; Harold V. Lee, Jr., M.E. '49; George Masters, C.E. '54; George A. Prusi, C.E. '42; Charles Swanson, M.E. '52; D. J. Vanderwall, M.E. '48; Harry Vanwyck, M.E. '49; and John Wozniak, E.E. '53. Ira Stricker, E.E. '53, is on military leave from the company. Lt. Harald Lee is on leave and is in the service. At present he is located in Kansas.

Miss Ethel Lyon, Ch.E. '34, is with the Institute for Air Weapons Research. This is an Air Force project operated by the University of Chicago. She lives at the Halsance Hotel, Stony Island and 60th St., Chicago, Illinois.

Harald Orchard, M.E. '54, is with the Douglas Aircraft Company and enjoys his work and the California sunshine very much. He and Nancy live at 9302 Lampson, Garden Grove, California. He reports that there are many opportunities for engineers at Douglas.

Rodney Hall, E.E. '52, is Electronic Engineer for the Navy Department, Bureau of Ships, Washington, D. C. He was married October 3, 1954, and is living at 5614 Third St., N.W.

Charles A. Bowser, C.E. '33, formerly of 1536 Spencer Ave., Lansing, was appointed Director of Underwriting for the Federal Housing Administration in Washington, D. C., on April 26, 1954. He holds one of the top positions in the agency. His wife and two daughters have joined him in Washington.

Paul Theroux, C.E. '47, reports a change of home address to 54 Westbrook Road, Westfield, New Jersey. He is with the Boston Manufacturers Mutual Fire Insurance Company.

The Standard Oil Development Company has just announced the appointment of Mr. Hubert A. Pattison, Ch.E. '50, to the staff of its Patent Division. Prior to this appointment he was a patent examiner with the United States Patent Office. After receiving his B.S. at State he earned his L.L.B. from George Wash-

ington University. Hubert lives at 540 Westminster Ave., Elizabeth, New Jersey.

Herman "Herkie" Bowers, M.E. '50, is Staff Engineer for the Mergenthaler Linotype Co. in Brooklyn, New York. His home address is 19 Miller Road, Farmingdale, L. I., N. Y. In December '54, during the annual ASME meeting, he was chairman of arrangements for the first Michigan State College Alumni Dinner in connection with the meeting. Twenty-six attended and plans were made for it to become an annual affair. Herkie, you may recall, was editor of the *Spartan Engineer* in 1950.

William E. Johnson, C.E. '52, is Project Engineer for the Goodyear Atomic Corp. He was married December 29, 1951, and has a son, James Clifford, who was born July 3, 1954. His home address is Route No. 1, Box 327, Piketon, Ohio.

Gerald Westbrook, C.E. '54, is with the Corps of Engineers, U. S. Army, Portland, Oregon, District 6. While he is gaining good experience, George thinks Michigan is a very attractive state and he is hoping to locate here before too long.

Paul Eaton, M.E. '52, is with the Ford Motor Company as Production Draftsman and lives at 6314 Schaefer Road, Dearborn. Paul was recently discharged from the army.

Thomas Hamilton, M.E. '52, writes that his position is in Post Ordnance Guided Missile Office at 24 Sheridan, Illinois. He is working on underground launching sites in the Chicago area and lives at 2008 Little Fort Road, Fort Sheridan, Illinois.

Gerald W. Theide, M.E. '52, is Lt. J.G. in the U. S. Navy. He is doing maintenance engineering work in an aircraft fighter squadron. His present address is VF-153, F.P.O., San Francisco, California. He plans to return to Michigan when he is released from the service in September, 1956.

from Kentucky Engineer

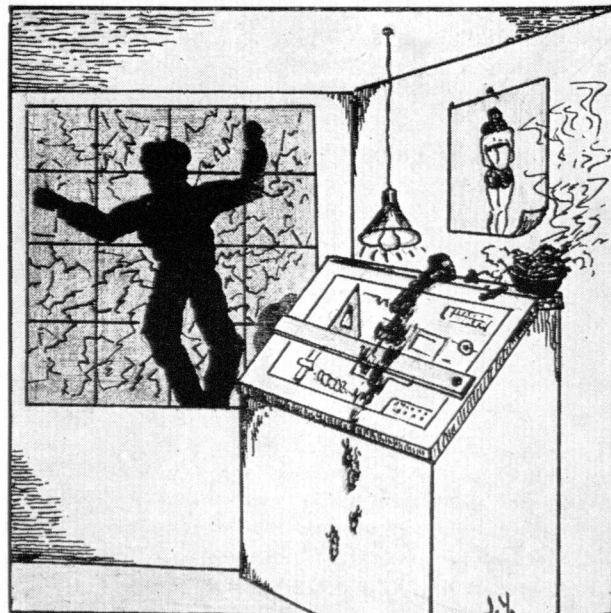



## **A**tomistic Globe Circling

... will become a reality during your engineering career.

When that day comes, you may be certain our engineers will have played a major role in developing the nuclear engines that will make such flights possible.

Solving tough problems like this has made Pratt & Whitney Aircraft the world's foremost designer and builder of aircraft engines. This is the reason why it is first-choice of so many forward-looking technical graduates.

**PRATT & WHITNEY AIRCRAFT**  
DIVISION OF UNITED AIRCRAFT CORPORATION  
EAST HARTFORD 8, CONNECTICUT



## Opportunity and Security go arm in arm at Columbia-Southern

Columbia-Southern ranks high as a company in which to make a career.

Columbia-Southern has been happy, too, with its good fortune in adding so many fine men to its organization over the past years.

Columbia-Southern has many inviting advantages. It is rich in opportunity. Columbia-Southern believes in allowing maximum flexibility and personal contact between the individual and his supervisors. The corporation wants each member to progress as rapidly as he can. Responsibilities are increased as rapidly as the individual demonstrates his ability to handle them.

Columbia-Southern has appeal in its security, too. In the nation's complex modern economy, no industry or company can expect to remain unaffected by general business conditions. Because Columbia-Southern's products have diversified applications in

many essential industries, Columbia-Southern is less likely than most companies to be seriously affected by a general decline in business activity.

Columbia-Southern is a sound progressive company that abounds in opportunity. We are looking for technical graduates in many fields. If you would like to become a part of the growing Columbia-Southern organization, write Dept. P at our Pittsburgh address or any of the plants.

### COLUMBIA-SOUTHERN CHEMICAL CORPORATION

SUBSIDIARY OF PITTSBURGH PLATE GLASS COMPANY

ONE GATEWAY CENTER · PITTSBURGH 22 · PENNSYLVANIA



DISTRICT OFFICES: Cincinnati • Charlotte • Chicago • Cleveland  
Boston • New York • St. Louis • Minneapolis • New Orleans  
Dallas • Houston • Pittsburgh • Philadelphia • San Francisco  
PLANTS: Barberton, Ohio • Bartlett, Calif. • Corpus Christi, Texas  
Lake Charles, La. • Natrium, W.Va. • Jersey City, N.J.



## MAGNESIUM

by Denton D. McGrady, Metallurgical Engineering Department  
Michigan State College

**T**OUCHED IN THE HEAD would have been the comment a few years ago about anyone who believed metal could be recovered from the ocean. Today it is a fact. The metal, magnesium, is extracted from the sea water by using oyster shells, natural gas, and electricity. A dream? No, this is truly America in the Age of Science and Engineering.

Metallurgists have known for many years that one pound of magnesium was present in each ninety-two gallons of ocean water. So vast was this potential "ore" of magnesium that it offered a fascinating challenge to modern industrial technique to wrest this metal from the sea and put it to use in aircraft and transportation equipment, home appliances, portable tools, furniture, or where ever light-weight is an important engineering or economic factor. Magnesium is known to industry as the lightest structural metal.

Perhaps no engineering accomplishment of this character better illustrates the fine cooperation and coordination between the research chemist and the engineer which is necessary in such undertakings. Laboratory studies by the research chemist showed that, under controlled conditions of acidity, temperature, and agitation, the magnesium in sea water could be precipitated as an insoluble solid compound by the use of slaked lime. This precipitate, which is commonly known as milk of magnesia, could then be filtered and separated from most of the sea water. By adding dilute hydrochloric acid to neutralize the precipitated magnesium hydroxide a solution of magnesium chloride was obtained. The solution of magnesium chloride thus obtained could be evaporated and dried to yield pure, water-free, crystals of solid magnesium chloride which were fed into a molten bath at 1300°F. in an electrolytic cell where the crystals melted and were decomposed by direct current electricity into molten magnesium metal and chlorine gas.

Chemical engineers and metallurgical engineers were placed in charge of the development of processes and design of equipment suitable for the economic commercial production of magnesium metal by the basic procedures originally established through research. It was the task of the engineer to transform a small-scale process of pints and pounds into a continuous, large-scale process involving hundreds of tons of solid and thousand upon thousand of gallons of sea water.

Previous to the use of sea water as a major source of magnesium, the raw material for magnesium pro-

duction had been the underground salt brines found extensively throughout the central area of lower Michigan. By regarding sea water as a very dilute brine solution, engineers were able to translate and apply much of their previous experience and "know-how" about salt brines to the sea water process.

A decision was made to locate the sea-water plant on the Gulf of Mexico coast at Freeport, Texas. This location resulted from an evaluation of such typical engineering and economic factors as: (1) the presence of an unlimited supply of uncontaminated warm sea water; (2) the presence on the nearby ocean floor of readily accessible beds of oyster shell which would be a source of lime; (3) the availability of ample natural gas for fuel at reasonable cost.

The sea water which contains some 0.13% magnesium is pumped into huge settling tanks and mixed with lime produced by the roasting of oyster shells dredged from the floor of the ocean. The calcium from the lime exchanges places with the magnesium in the sea water and the result is the precipitation of insoluble magnesium hydroxide in the form of a fine suspension which settles slowly to the bottom of the tank. The suspension of solid particles of magnesium hydroxide is dewatered and filtered to form a thicker suspension which is then converted into magnesium chloride in large neutralizing tanks by reaction with hydrochloric acid, prepared from natural gas and chlorine. The solution of magnesium chloride thus formed is evaporated to solid magnesium chloride crystals in direct-fired evaporators. The carefully dried crystals of magnesium chloride are then charged into electrolytic cells that are about 5 feet wide, 11 feet long, and 6 feet deep. Such cells are gas-fired and hold some 10 tons of fused or molten magnesium chloride. The temperature of the cell is above the melting point of magnesium. When a direct current of electricity passes through the cell chlorine gas forms at the graphite anodes and bubbles to the top of the bath where it is recovered, and later returned to the process after being reacted with natural gas to make hydrochloric acid. At the same time globules of molten magnesium metal, which are set free at the steel cathode, rise to the top of the bath because the molten magnesium is lighter than the fused salt bath in the cell. At about 4-hour intervals the liquid magnesium metal is dipped out and poured into notched ingots weighing about 17 pounds each.

The world need never fear a shortage of the raw materials needed to produce magnesium. Actually,

*(Continued on page 30)*



*Reliability...*

**A Key to K&E Leadership**

Measurements—by the mechanic or “Do-it-yourself” man working to sixteenths of an inch, or the engineer measuring to thousandths—must be reliable. K&E Steel Tapes—such as the original Wyteface®, the doubly durable Albadure®, the highly precise Optical Tooling Tapes—assure lasting legibility, sturdy endurance, essential precision. Such reliability is a key to K&E leadership in drafting, reproduction, surveying and optical tooling equipment and materials, in slide rules and measuring tapes.

**KEUFFEL & ESSER CO.**

EST. 1867

New York • Hoboken, N. J.

Chicago • St. Louis • Detroit • San Francisco • Los Angeles • Montreal

★  
**STAFF POSITIONS**

Open on The  
**SPARTAN  
ENGINEER**

★  
Apply Third Floor,  
**Union Building.**

★

**SO MUCH  
FROM SO LITTLE**

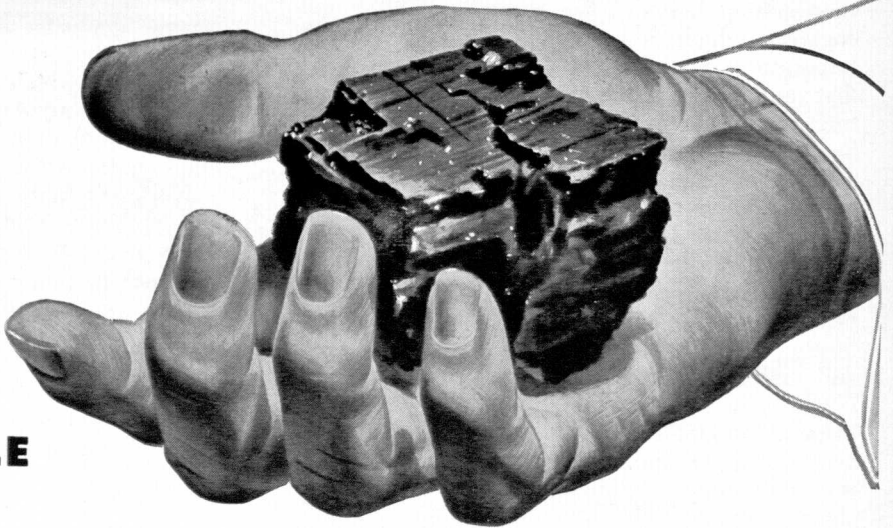

You're looking at a kilowatt-hour\* of electricity in its raw state—coal. This lump of coal weighs only 12 ounces. Not too long ago, the amount of coal required to produce a single kilowatt-hour of electricity was considerably larger and weighed 5 pounds. The difference between yesterday's 5 pounds and today's 12 ounces lies in improved steam technology, in better boilers—operating at higher pressures and temperatures—to make the steam that spins the turbines to make electric power.

Impressive as this progress appears, it represents only the current level of accomplishment in the quest for more and still more efficiency. Thanks to America's power en-

gineers, continuing advances in the fields of metallurgy, combustion and design will make it possible to squeeze even more energy from a lump of coal.

\*A kilowatt-hour will give you the power for, among other things, 10 solid hours of radio and recorded music, 14 hours of fan-cooling, better than 4½ hours of refrigeration operation.

**BABCOCK  
& WILCOX**



BOILER  
DIVISION

G-690

**Spartan Engineer**

# NEW DEVELOPMENTS

## Height Gage

A distinctly new and differently designed Height Gage has been introduced. It uses a triangular scale beam for superior strength and exceptional rigidity, preventing sway and vibration—a real advantage, particularly for layout and checking of large jigs, fixtures and machine parts.

Revolutionary new in design is the sliding head which moves through its entire range by the action of the full-length, large diameter screw in rear of the beam. The engaging nut is split and is disengaged for quick approximate setting of the head by simply pressing the two lugs on the sides and sliding the head along the beam.

One of the chief advantages is the location of the fine adjustment screw in the base. In making adjustments, the downward pressure on the screw helps to hold the gage even more firmly to the surface plate. This is contrary to the tendency towards tilting and unintentional moving of the gage in conventional Height Gages having the fine adjustment screw on the slide.

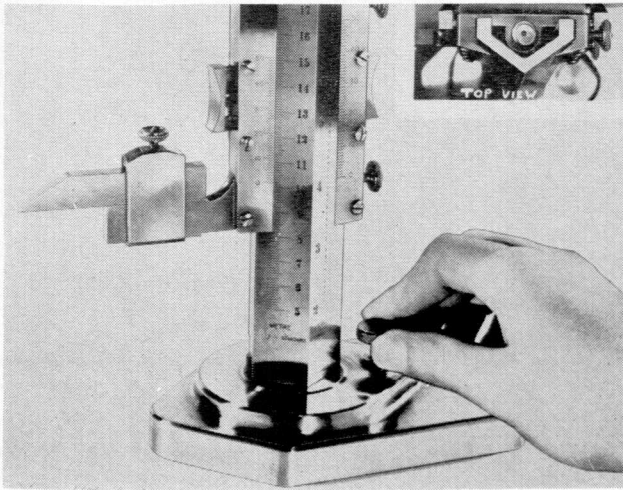

The Vernier is 2.450" long as compared to the  $\frac{5}{8}$ " long vernier commonly found on conventional Height Gages. Verniers are adjustable and the accuracy of the setting may be checked by use of a master gage block furnished with each Height Gage. A large, solid base, heavy enough to prevent tilting or toppling over, assures highest stability and accuracy. Available sizes are 12", 18", 24", 40" and 48".

## Traveling Locomotive School

As an aftermath to the diesel-electric revolution in railroads, the itinerant school master is again making an appearance on the American scene.

Five or six times a year, depending on the railroad demand, the General Electric Company sends out from its central maintenance school in Erie, Pa., a traveling "teacher" to aid roads requesting instruction on operating and maintaining G-E Diesel-Electric locomotives.



Highly accurate milling of aircraft and guided missile parts without machinery is possible with a new chemical milling process. A Materials Research and Process Engineer (left) explains the working of chemical milling. The "before" sample shows dark portions, specially masked to confine chemical milling only to desired areas. Several of many samples of work done by chemical milling are in the background.

Actual class room sessions are set up on railroad property and everyone, particularly shop men, who has anything to do with locomotives is invited to attend. "Texts" consist of instruction books explaining the hows and whys of operating, maintaining, and overhauling equipment.

The traveling school is an extension of its regular maintenance course held several times a year at the company's Locomotive and Car Equipment Department in Erie. Subject and frequency of these schools are also determined by customer demand. A locomotive school semester, on the average, is one week.

Last year there were two schools on industrial haulage equipment and two on medium sized switching locomotives. A special school was set up for one railroad that sent all of its shop personnel to Erie.

Railroad personnel come from half-way around the world to attend the Erie school, often on very short notice. The training given is usually on a specialized subject, although on certain occasions the entire field of locomotive and car equipment is included in the same course.

## Turbines for Helicopters

Gas turbine engines will give helicopters twice the power of piston engines of comparable weight. Weight to horsepower improvement is just one of the many reasons why gas turbines are "tailored to helicopter requirements."

Included in the list of advantages were fuel economy, low noise level, durability, and reliability. While the specific fuel consumption (pounds of fuel per

(Continued on page 30)

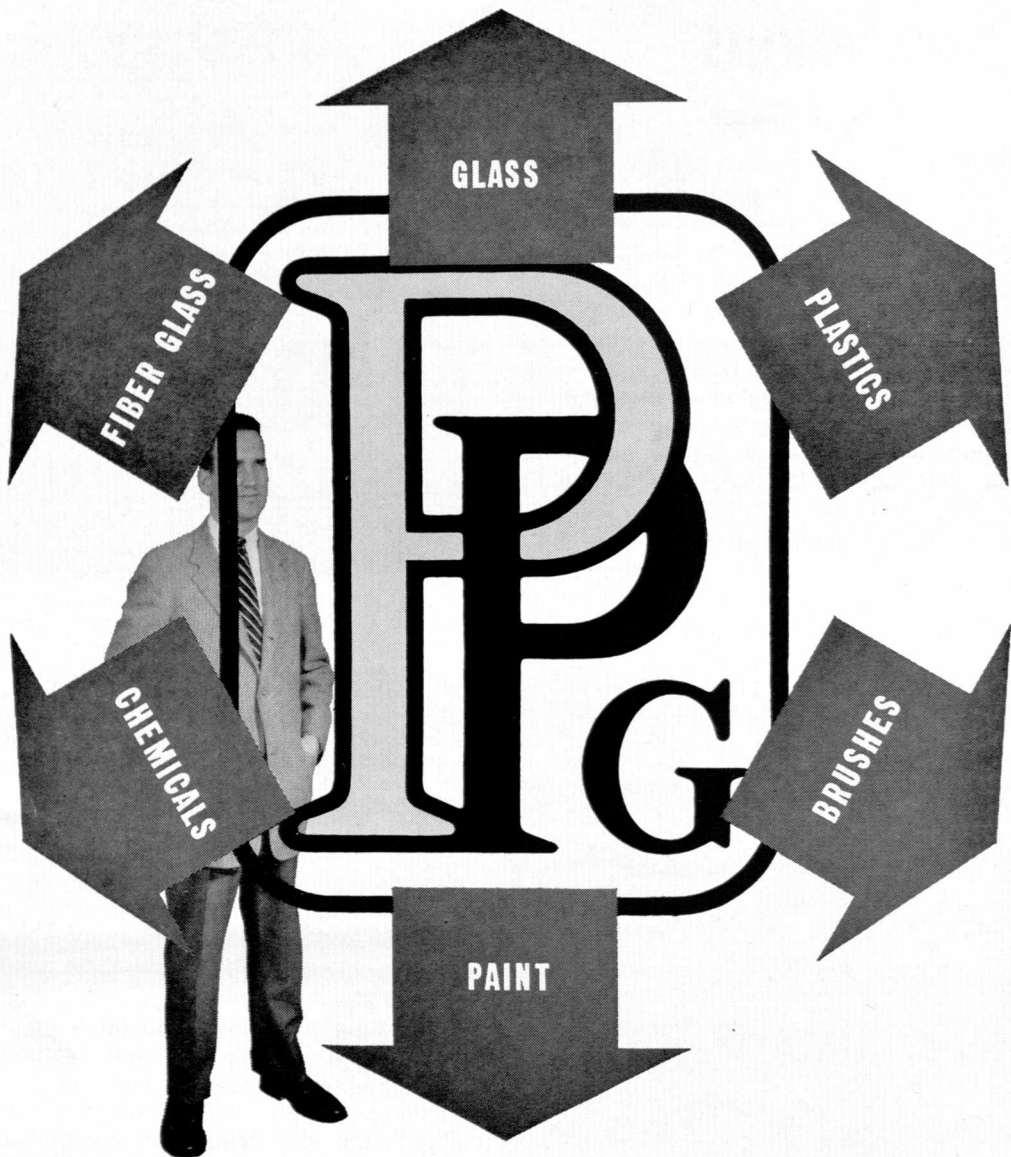

## PPG gives you the chance to "blossom out"

Your job with Pittsburgh Plate Glass can be in one of many fields because of the company's diversified operations.

As well as being the leading name in glass, it is also a prominent producer of paint, plastics, chemicals, brushes, and fiber glass.

In any one of "PPG's" several divisions you will find a challenge and an opportunity. A challenge to you to help create and produce new and better products. An opportunity to have your training and talents recognized and rewarded.

In addition, Pittsburgh Plate Glass offers unusual security and strength by virtue of being, as a whole, one of the nation's leading "blue-chip" industries.

Pittsburgh Plate Glass gives you the chance to blossom out. It believes in stimulating constructive thinking and action. It wants its men to do the type of work for which they are best suited, in which they are happiest, and in which they can advance to bigger and more responsible jobs in the PPG organization.

With an impressive record of sound growth and an even greater potential ahead, Pittsburgh Plate Glass offers many opportunities in varied fields. Good men are needed. If you would like to learn more about these opportunities, write today to Pittsburgh Plate Glass Company, General Personnel Director, One Gateway Center, Pittsburgh 22, Pennsylvania.



PAINTS • GLASS • CHEMICALS • BRUSHES • PLASTICS • FIBER GLASS

**PITTSBURGH PLATE GLASS COMPANY**

319 PLANTS, MERCHANDISING BRANCHES, AND SALES OFFICES LOCATED IN 250 CITIES

# Construction of a Generator-Type Dynamometer

Jack Crane, A.E., '55

THE AGRICULTURAL ENGINEERING DEPARTMENT of Michigan State College offers a special problem course in which students are permitted to carry out some project or test which will be of value to the department. Upon completion of the project, a standard engineering report must be submitted to the instructor. The design and construction of this generator-type dynamometer was such a project. The ultimate objective of the project was its use in class demonstrations pertaining to the construction and operation of electric dynamometers in general. Before explaining the actual details of construction, a brief summary of the theory of electric dynamometers is in order.

The dynamometer is a device used for the measurement of power produced by a rotating shaft. Power is defined as "the time rate of doing work," or  $P$  equals torque times angular velocity. To determine the torque of the engine at any load or speed, when using an electric dynamometer, the basic principle of the generator is used. When a conductor moves across a magnetic field, a voltage is produced which is directly proportional to the intensity of the field. The relation between velocity, electromotive force, and the magnetic field for a generator is as follows:

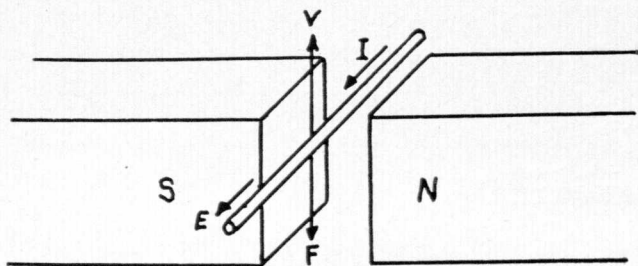

When the conductor rotates in a magnetic field with a velocity of  $V$ , a force  $F^1$  will be exerted on the magnetized poles, which will be equal and opposite to the force  $F$  on the conductor. In an actual generator, this force  $F^1$  is absorbed by the base support, but by allowing the entire generator stator to rotate about its armature, the force  $F^1$  can be easily measured. By knowing  $F^1$  and the distance it acts through, the motor torque can be determined. Now, since the torque and angular velocity are known, the brake horsepower can be obtained by the previously mentioned relation, with a proper adjustment of units. An explanation of the various types of dynamometers in general use will follow.

The most simple type of dynamometer is the Prony friction brake. This type is suitable for the measurement of small amounts of power from shafts with a low peripheral speed. The construction of this device is relatively simple, consisting of a lever connecting to the revolving shaft or pulley in such a manner that the friction induced between the surfaces in contact will tend to rotate the arm in the direction in which the shaft revolves. The lever terminates on a knife edge platform scale which is used to determine the

torque transmitted at various shaft speeds. That the measure of friction is equivalent to a measure of the work of the shaft is evident when one considers that the entire driving power of the shaft is expended in producing the friction at the required number of revolutions per minute, and this driving power is equal to the mechanical effect of the shaft when running at the same speed in the performance of useful work.

An electric generator type dynamometer is used for testing automobile, tractor, and other motors which produce relatively large amounts of power at a moderate speed. The one disadvantage of this type is that if its maximum speed is exceeded, the great centrifugal force exerted on the armature windings may cause damage or failure to the dynamometer. This defect is corrected in the construction of an Eddy-current dynamometer, which will be discussed later. The generator-type dynamometer consists of an electric generator supported on its bearings and connected by a flexible coupling to the motor to be tested. The torque is measured from the pull exerted on a scale, which must be calibrated with great accuracy. On the dynamometer illustrated in this report, a scale with a maximum range of 10 pounds subdivided into 1/100 of a pound was used to insure accuracy. By weakening the field of the dynamometer, the speed of the engine under test can be varied, and in this way, values can be obtained for plotting the power curve of the engine. With this form of dynamometer, it is possible to return the generated energy into the shop line instead of wasting the power, as is usual with dynamometer work. In this machine the electrical readings have nothing to do with the measurement of power. However, an electric motor may be used as a dynamometer with a very high degree of accuracy, providing the motor is properly calibrated, and the efficiency factor thus obtained is used in determining the power transmitted to the machine being tested.

The Brackett cradle dynamometer consists essentially of a strong platform, furnished with two rigid uprights carrying steel knife-edges from which the platform is suspended. A graduated horizontal lever which carries a sliding weight is attached to one of the swinging uprights, near the knife-edge. Adjusting screws are provided so that the axis of rotation of the armature of any given machine may be made to coincide with the axis of oscillation of the cradle. The tendency of the driving belt to rotate the machine may be weighed on the scale beam, and this will give a measure of the power transmitted when the speed is known.

The Eddy-current dynamometer is essentially an electric generator with alterations performed on the armature and field windings. The torque is measured by scales, as with any absorption dynamometer. The rotating element of the of the Eddy-current dynamometer is a solid steel casting with tapered teeth projecting in the form of poles. The stator is free to

(Continued on page 40)



**LUCKILY,  
EUCLID WAS  
A GREEK**

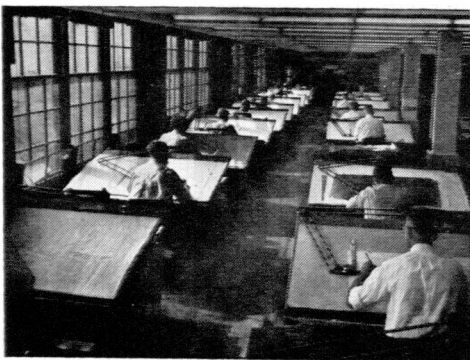

From the drawing boards at New Departure have come many of the world's ball bearing advancements. Such leadership is one reason why engineers everywhere specify New Departure ball bearings.

If Euclid had lived 2,300 years longer, he would have made Tau Bete. That's why he's pictured here wearing the Tau Beta Pi key.

After all, every engineer owes Euclid a big debt. At New Departure, for example, we work with circles and spheres. Without Euclid, we might still be getting started.

As it is, though, New Departure has gone further with spheres and circles in relation to moving parts than anyone else in the world. From this knowledge have come such advances as the Sealed-for-Life and the double-row angular-contact ball bearings. And it's advances like these that make New Departure the world leader in ball bearings.

NEW DEPARTURE • DIVISION OF GENERAL MOTORS • BRISTOL, CONN.

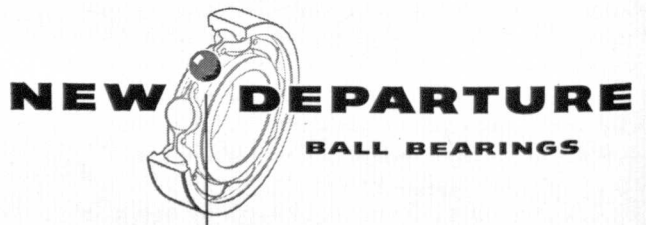

NOTHING ROLLS LIKE A BALL

A MESSAGE TO  
COLLEGE ENGINEERING  
STUDENTS

from C. H. Weaver, Manager,  
Atomic Power Division,  
Westinghouse Electric Corporation  
*University of Pennsylvania, 1936*

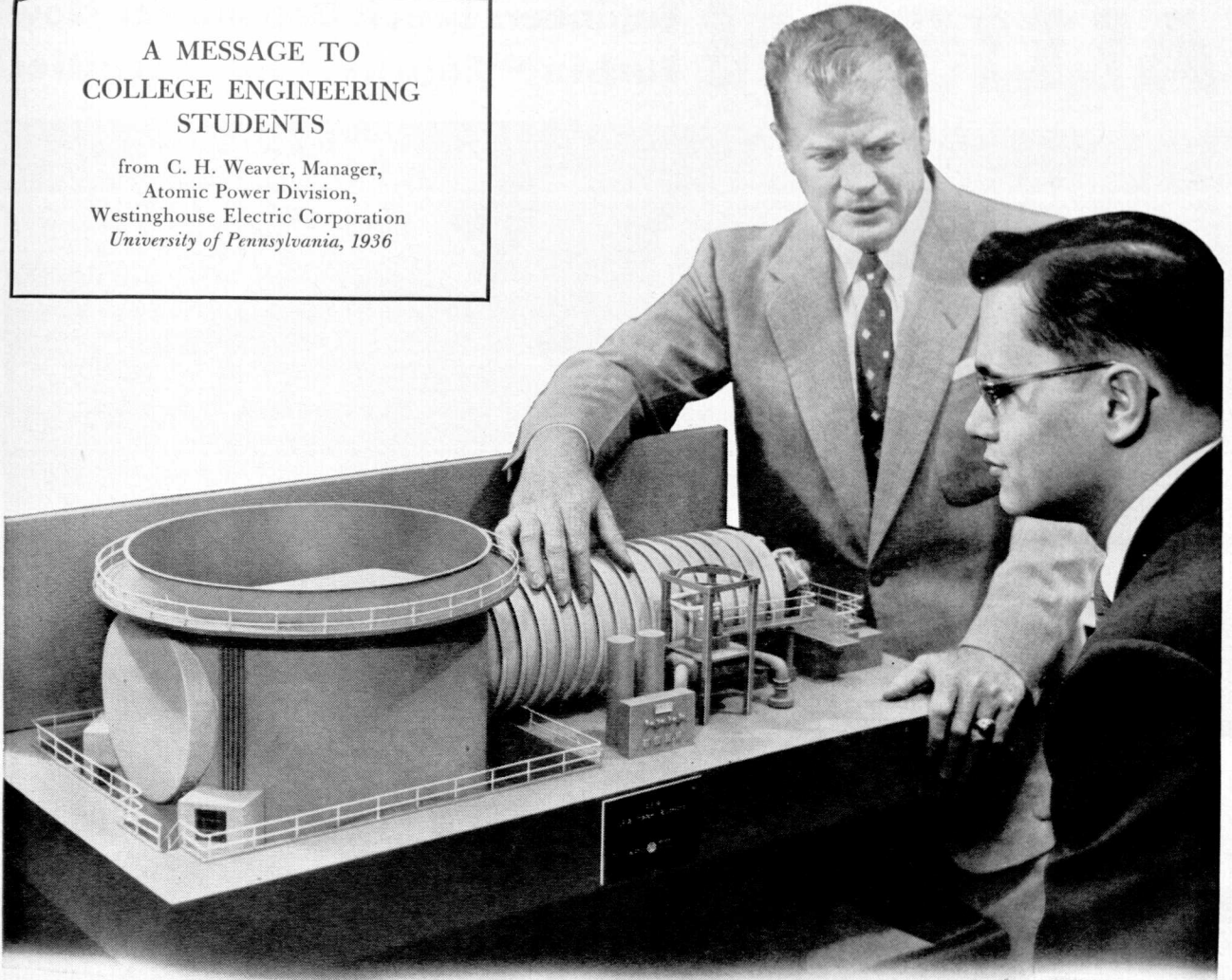

## To you who want to help create the atomic age

You're looking at the practical beginning of an atomic age.

This is a model of the land-based prototype for the first atomic submarine engine, designed and built by Westinghouse—working with the Atomic Energy Commission and the U. S. Navy.

And now, Westinghouse is developing the world's first atomic power plant to harness this vast power for peacetime use. Its output, enough for a city of 100,000 people, will go into a utility's power system.

Since 1948, Westinghouse has had an Atomic Power Division for atomic energy development . . . and it now has an Atomic Equipment Department to develop apparatus for atomic power installations. These are typical of the steps our forward-looking

Westinghouse management is constantly taking in leading the way toward development of new sources of energy and new products.

Wouldn't you like to be with Westinghouse . . . helping to create this new era?

We at Westinghouse are interested in you as an *individual* . . . interested in your ambitions as well as your technical ability. For your professional development, there is a Graduate Study Program, available in 19 universities, and leading to your Master's and Ph.D. degrees. And there are other Westinghouse programs to fit your individual needs . . . all aimed at helping you reach your goal.

G-10281

YOU CAN BE **SURE**...IF IT'S  
**Westinghouse**

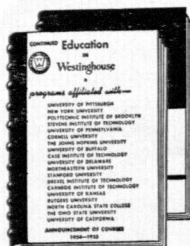

Ask your Placement Officer about career opportunities at Westinghouse, or write for these two booklets: *Continued Education in Westinghouse* (describing our Graduate Study Program) and *Finding Your Place in Industry*.

To get these booklets, write: Mr. J. O. Campbell, Regional Educational Co-ordinator, Westinghouse Electric Corporation, 306 Fourth Ave., Pittsburgh 30, Pa.

# ALLISON Engineers Break Ground for New Turbine Engine Test Facilities

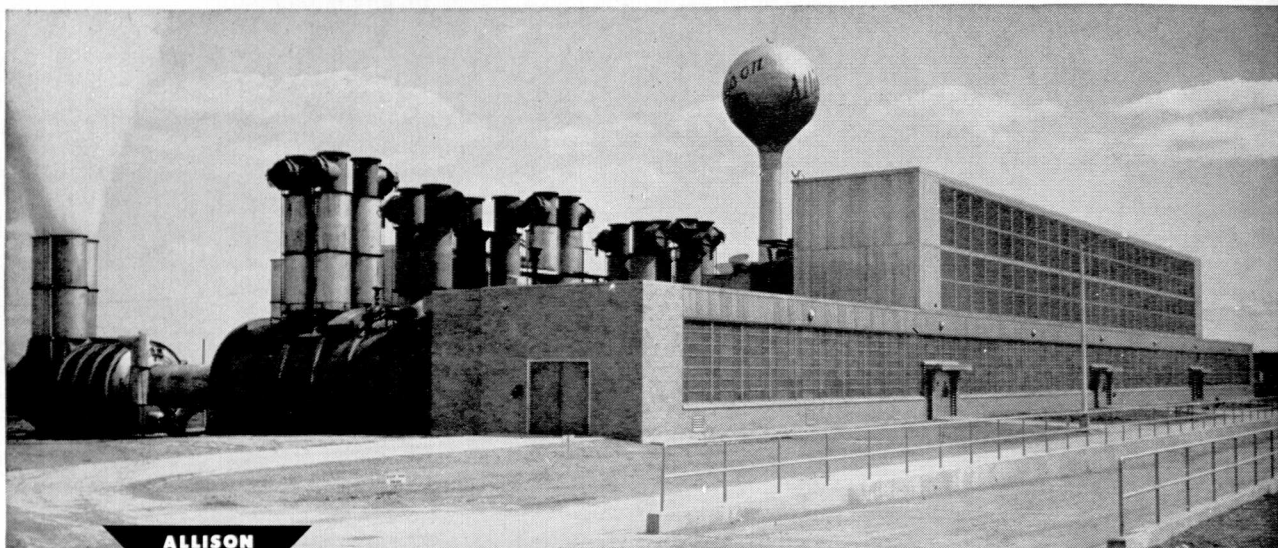

**ALLISON  
PLANT  
8**

E. B. NEWILL, Georgia Tech, '15, now General Manager, Allison Division and Vice President of General Motors Corporation, breaks ground on another addition to our turbine engine test facilities.\*



Allison Jet engine designers soon will have even larger and improved test facilities to use in developing turbo-jet engines.

Performance requirements for future military and commercial aircraft make necessary the development of new turbo-jet engines far more complex and powerful than present types. New and specially-designed test equipment is required to accurately determine per-

formance of the principal engine components—compressors, turbines, and combustors—before the complete engine is tested.

For instance, capacity for 75,000 horsepower is being established to pump air at the rate of 300 pounds per second. This air must be compressed and heated to 1000 degrees, or cooled to a minus 67 degrees, enabling Allison to test combustors at simulated altitudes up to 65,000 feet.

With our expanding and long-range engineering program, we need additional young engineers. Allison, a leader in the design, development and production of turbo-jet and turbo-prop engines, NOW offers young graduate engineers unusual opportunities for progress where future development is unlimited.

Write for information:

R. G. GREENWOOD, Engineering College Contact  
ALLISON DIVISION, General Motors Corporation  
Indianapolis 6, Indiana

\* Left to right—Dimitrius Gerdan, Chief Engineer, Turbo-Jets, U. of Michigan, 1932, BS in Mechanical Engineering and Industrial Engineering; T. W. Meeder, Chief Test Engineer, U. of Michigan, 1932, MS in Aeronautical Engineering; R. E. Settle, Assistant Director of Engineering, Purdue University and Indiana Central College, BS in Mathematics; Paul Hunt, representing Huber, Hunt & Nichols, Inc., contractor; E. B. Newill, Georgia Institute of Technology, degrees in Mechanical and Electrical Engineering; Harold H. Dice, U. of Illinois, 1929, BS Business Administration; Col. S. A. Dallas, USAF Plant Representative; R. M. Hazen, U. of North Dakota, U. of Michigan, 1922, BS in Mechanical Engineering and attended graduate school, U. of Minnesota, majoring in Metallurgy.



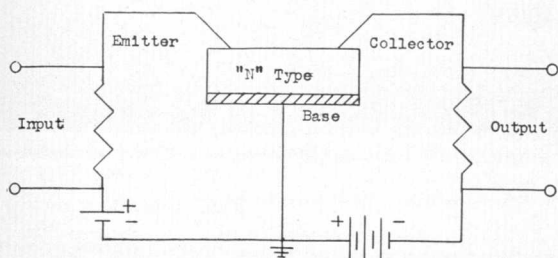

Figure 1 - Point-contact transistor with grounded-base circuit.

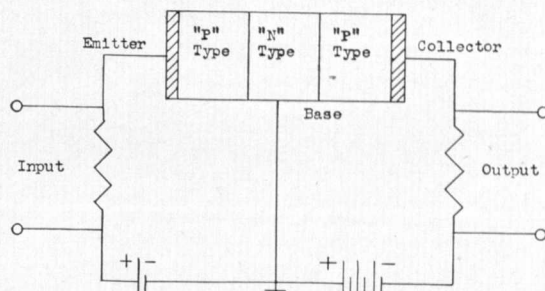

Figure 2 - P-N-P junction transistor with grounded-base circuit.

# THE TRANSISTOR

by Robert E. Fredericks, E.E. '57

**E**LECTRONICS, a branch of physics concerning the study of electric current flow, has had two major developments in the last 50 years. One is the development of the vacuum tube, in 1907 by Lee DeForest; more recently, the transistor has expanded the field of electronics to inconceivable limits.

The vacuum tube is the center of most all electronic devices. Circuits are built around the vacuum tube to give us increased power and many other desirable necessities in electronics. The simplest tube is the diode vacuum tube which has two main parts, the cathode and the plate. The cathode of a vacuum tube when heated emits negative charged electrons and is generally made of a material that has an abundance of free electrons in its construction. The cathode of the vacuum tube is either directly heated or has a heater filament that heats the cathode. As a result, a radio does not play the instant it is turned on because it takes time to heat the cathode so it will emit electrons. The plate of the diode vacuum tube is the collector of electrons and has a positive charge to attract the negative charged electrons. These tube components are sealed inside a glass bulb from which almost all air has been removed. This vacuum permits the electrons to flow without opposition. There are many more types of vacuum tubes, but they are fundamentally variations of the diode discussed here. The use of vacuum tubes has many limitations because of their size and the large amount of power necessary for operation.

Bell Telephone Laboratories have recently developed the transistor. The purpose of this paper is to discuss the transistor, one of the newest devices in the field of electronics.

The transistor is an amplifier of electrical signals designed to replace the vacuum tube. The transistor was invented 6½ years ago by a group under Bell Laboratories' Dr. William Shockley. It is capable of performing many of the functions of the vacuum tube, in addition to opening new fields of application that were not possible with the vacuum tube. Unlike the

vacuum tube, the transistor functions on the principle of controlled electron flow within a solid; whereas, the vacuum tube functions on the principle of electron flow through a vacuum to a collector or plate.

Transistors are made of certain solids called semiconductors. A conductor is an element that has the ability to transfer electric current with little opposition. A semiconductor is an element that transfers electric current, but with a certain degree of opposition. The electrical characteristics of a semiconductor can be precisely controlled by regulating the amount of impure atoms it contains. If no impurities are present in the semiconductor, no transistor action takes place. If too many impure atoms are present, the semi-conductor becomes too conductive and transistor action is adversely affected. The impurities, which insure good transistor operation, should be present in the ratio of less than one atom to every ten million semiconductor atoms.

Most of today's transistors use germanium as its semiconductor. Great progress has been made in developing germanium pure enough to use in transistors. This progress was due to the great demand for germanium of high perfection placed on the chemists by the electronic engineer. As a result, we now have a large supply of perfected germanium available today. Experiments in transistor electronics, which would have been impossible in the past, can now be performed. Most germanium in the United States is obtained as a byproduct of zinc mining. It has also been obtained in considerable quantities in Great Britain from blue dust residue. Heat and moisture adversely affects the transistor action in germanium. At the present time the price of germanium powder is about 300 dollars per kilogram. The quantity of germanium used for one transistor is about .002 grams.

An aluminum-antimony mixture is in the early stages of being used as a semiconductor, because it will withstand high temperatures. Silicon also is a good semiconductor for transistors, but chemists have not as yet found a way to obtain it pure enough for transistors.

(Continued on page 44)

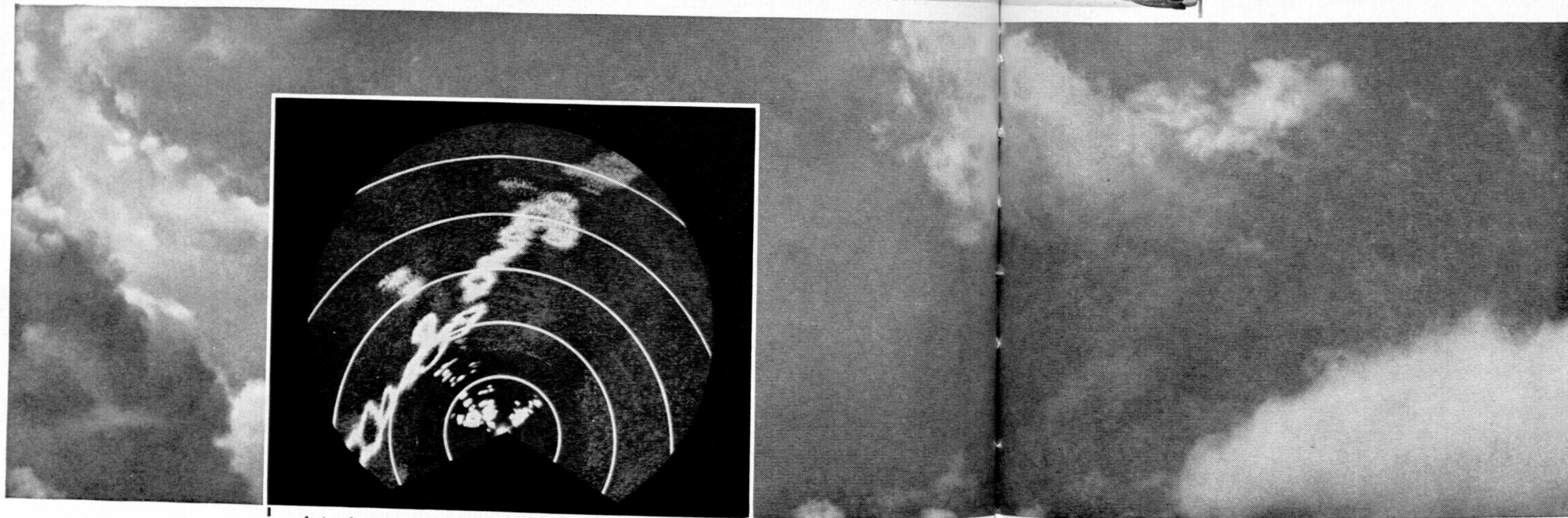
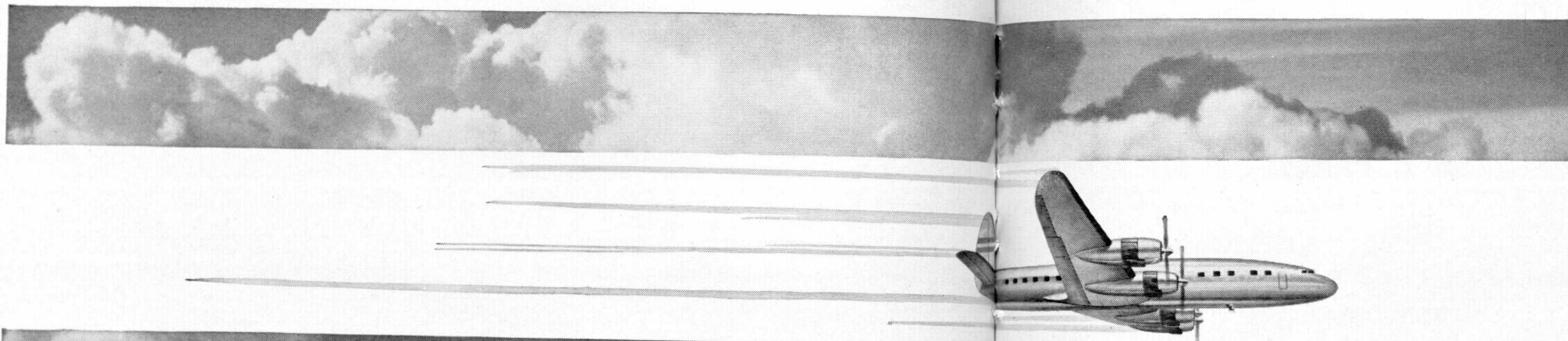

Actual storm ahead as pilot sees it on radar scope. It indicates that, by changing course very slightly, he will find a smooth, safe route.



PRINCIPAL DIVISIONS AND BASIC PRODUCTS

- BENDIX RADIO, TOWSON, MD.  
radar; auto, railroad, mobile and aviation radio; television.
- ECLIPSE MACHINE, ELMIRA, N. Y.  
bicycle coaster brakes, Stromberg carburetors, electric fuel pumps, starter drives.
- SCINTILLA, SIDNEY, N. Y.  
aviation ignition systems; industrial engine magnetos; diesel fuel injections; electrical connectors; ignition analyzers.
- ZENITH CARBURETOR, DETROIT, MICH.  
automotive, marine and small engine carburetors.
- BENDIX-SKINNER, DETROIT, MICH.  
micronic filters.
- PACIFIC, NORTH HOLLYWOOD, CALIF.  
telemetering equipment; hydraulic and electric actuators; depth recorders; boat steerers.
- BENDIX FRIEZ, TOWSON, MD.  
meteorological instruments, precision instruments and recorders.
- BENDIX PRODUCTS, SOUTH BEND, IND.  
automotive brakes, carburetors, power steering; aviation brakes, landing gear, fuel metering.
- ECLIPSE-PIONEER, TETERBORO, N. J.  
aviation instruments and components; foundry.
- MARSHALL-ECLIPSE, TROY, N. Y.  
brake blocks, brake lining, synthetic resins.
- RED BANK, EATONTOWN, N. J.  
electronic tubes; dynamotors, inverters.
- CINCINNATI, CINCINNATI, OHIO  
automatic viscosity regulators, nuclear products.
- BENDIX COMPUTER, LOS ANGELES, CALIF.  
digital computers.

# Bendix AIRBORNE RADAR...

Bendix\* Airborne Radar, a device carried right in the airplane to spot storms miles ahead, has been used by the military for several years. Now Bendix is supplying it to airline and company-owned aircraft.

This new device does what human eyes cannot do. It not only sees up to 150 miles ahead, even in the blackest night, but also looks right through storms and shows their size and intensity.

In the small photo above, for example, you can see white areas which are a line of storms. Those with black centers represent great turbulence. With only a slight change in course the pilot avoided these storms.

Airlines are buying Bendix Airborne Radar because it makes possible a more comfortable, swifter ride on a more direct course. Without airborne radar it has often been necessary to fly many extra miles to avoid storms whose areas and intensities were not definitely known.

Pilots hail it as one of aviation's most important developments, not only because of its storm-warning accuracy, but because it also acts as a navigational aid. Even in heavy overcasts it can see rivers, mountains and the outline of the terrain below. Write Bendix Radio Division in Baltimore for further information.

This is one of the hundreds of products Bendix has

finds a smooth corridor through stormy skies!

developed and manufactured for the aviation industry. We also make hundreds of other automotive, electronic, nuclear and chemical components and devices for those and scores of other industries. A request on your company letterhead will bring you "Bendix and Your Business"

—the complete Bendix story on how we can contribute to your business. For engineers interested in a career with us, we have another booklet "Bendix and Your Future."

BENDIX AVIATION CORPORATION  
Fisher Building • Detroit 2, Michigan

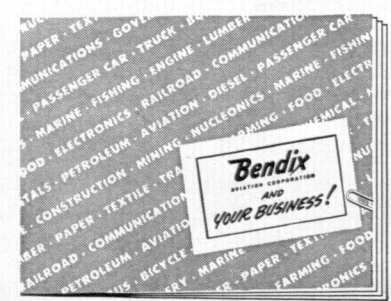

- HAMILTON, HAMILTON, OHIO  
jet engine controls and aircraft pumps.
- LAKESHORE, ST. JOSEPH, MICH.  
power steering and automotive devices.
- UTICA, UTICA, N. Y.  
aviation components.
- MONTROSE, SOUTH MONTROSE, PA.  
aviation components.
- PIONEER-CENTRAL, DAVENPORT, IOWA  
aviation instruments and components.
- YORK, YORK, PA.  
electronic devices; test equipment.
- BENDIX-ECLIPSE OF CANADA, LTD.  
Windsor, Ont.
- BENDIX INTERNATIONAL  
New York City

\*REG. TRADE-MARK

# A Machine Designer's Protest of a Protest

by Ching-u Ip, Mechanical Engineering Department,  
Michigan State College

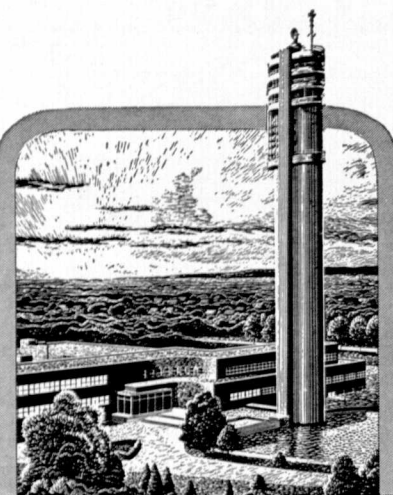

## A Tower of Opportunity

for America's young  
engineers with capacity for  
continuing achievements in  
radio and electronics

Today, engineers and physicists are looking at tomorrow from the top of this tower . . . the famed Microwave Tower of Federal Telecommunication Laboratories . . . a great development unit of the world-wide, American-owned International Telephone and Telegraph Corporation.

Here, too, is opportunity for the young graduate engineers of America . . . opportunity to be associated with leaders in the electronic field . . . to work with the finest facilities . . . to win recognition . . . to achieve advancement commensurate with capacity.

Learn more about this noted Tower of Opportunity . . . its long-range program and generous employee benefits. See your Placement Officer today for further information about FTL.

### INTERESTING ASSIGNMENTS IN—

Radio Communication Systems  
Electron Tubes  
Microwave Components  
Electronic Countermeasures  
Air Navigation Systems  
Missile Guidance  
Transistors and other  
Semiconductor Devices  
Rectifiers • Computers • Antennas  
Telephone and  
Wire Transmission Systems

**Federal  
Telecommunication  
Laboratories** DIVISION OF I.T.T.

A Division of International  
Telephone and Telegraph Corporation  
500 Washington Avenue, Nutley, N. J.

SOME TIME AGO William Faulkner, in a letter to the New York Times, contended that the passengers and crew of the Italian airliner, which crashed at New York's Idlewild Airport, were victims of "that mystical, unquestioning, almost religious awe and veneration in which our culture has trained us to hold gadget." He further stated: "We all had better grieve for all people beneath a culture which holds any mechanical (gadget) superior to any man simply because the one, being mechanical, is infallible, while the other, being nothing but man, is not just subject to failure but doomed to it."

Whatever is the real reason of that tragic crash there is no doubt that most laymen have insufficient understanding of "mechanical gadgets"—they either consider them something magical, or as Faulkner implied, something based and evil, even though necessary. At any rate Faulkner certainly would not speak with the same tone about the Mona Lisa or the Shakespeare first folios.

This brings our protest of the protest.

A machine designer is the last person to assert that a machine or a mechanical instrument is infallible. The "thinking machines," which now capture the imagination of the public, are anything but superior to the human brain. (See the discourse of Norbert Wiener on a computer for translating foreign languages.) The idea of a mechanical Frankenstein is simply absurd to a man of science. A machine designer designs his machine with much thought, love, and workmanship utilizing often the scientific principles discovered by the Great Masters of the Past, much the same as a writer composes a piece of literature quoting here and there words and phrases of the Past Masters.

In the days of Aristotle and Archimedes the study of geometry and mechanics was the highest of cultural endeavours. Science yet is the most lustrous gem of our present day culture; possesses all its inherent beauty and fascination. This should not be a surprise to anybody, for scientific discoveries, too, are fruits of great thinking. Leonardo da Vinci's achievement in painting, his study of the anatomy of the human body, and his mechanical inventions were all but one cultural pursuit and not symptoms which showed the many facets of a split personality. The same can be said about Benjamin Franklin's varied accomplishments.

Science has progressed far since the days of Newton; literature has not gone equally far since the days of Shakespeare. Many of our leading scientists of today have great understanding and appreciation of literature. How many of our men of literature have an understanding and appreciation of science? If our men of literature and the public have greater understanding of our scientific culture, then they not only will not regard mechanical inventions with "religious awe," but they also will think of them as objects of Art, and not as evil items concocted by witch doctors!

# 12 of the basic industries in which Bendix products play a vital role

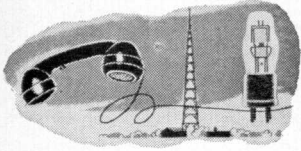

ELECTRONICS

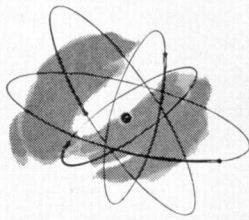

ATOMIC ENERGY

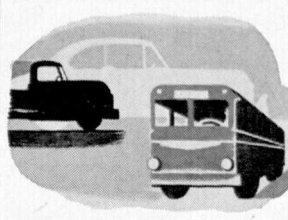

AUTOMOTIVE

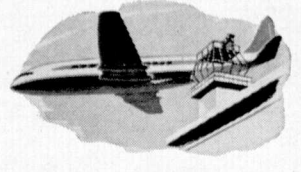

AVIATION

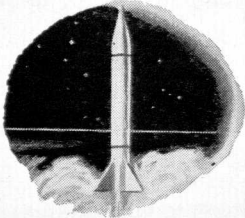

GUIDED MISSILES

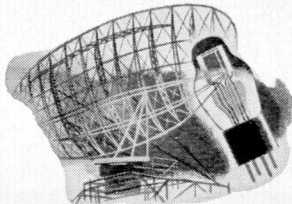

RADAR

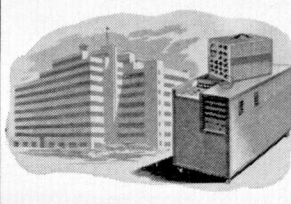

COMPUTERS

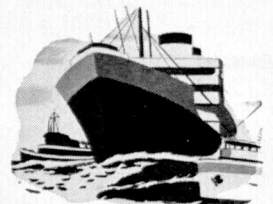

MARINE

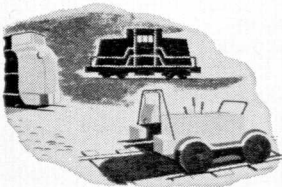

RAILROAD

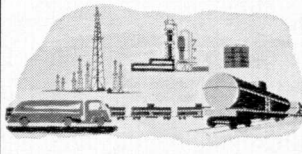

PETROLEUM

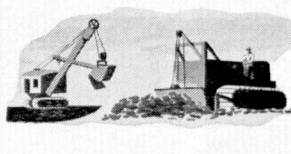

CONSTRUCTION

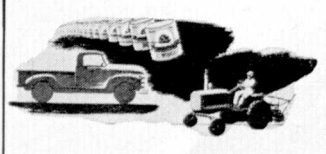

AGRICULTURE

## A SOUND REASON WHY *Bendix* OFFERS TODAY'S ENGINEERING GRADUATE AN UNLIMITED FUTURE!

Diversification is an important asset in business.

Especially so from the viewpoint of the engineer because:

It encourages and promotes freedom of ideas. Keeps engineering ingenuity flexible and adaptable. In short, gives full vent to an engineer's creative ability . . .

While at the same time it provides a healthy, stable, secure foundation for both the company and the individual to build and expand.

If diversification in business appeals to you as a graduate engineer, you'll be greatly interested in the Bendix Aviation Corporation.

For Bendix is unlike any other company in America in its versatility, facilities, experience, range of products and different fields of engineering endeavor. Nearly a

thousand different products are produced by our 24 manufacturing divisions.

As a result, we not only offer a wide choice of locations coast to coast but also career-building opportunities as broad as your ambition and ability in mechanical engineering . . . hydraulic mechanisms . . . electronics . . . magnetics . . . computers . . . servo-mechanisms . . . radar research . . . metallurgy . . . solid-state physics . . . instrumentation . . . radiation detection . . . nuclear physics . . . guidance and control systems plus many more engineering fields of challenge.

Write for your copy of "Bendix and Your Future." It gives the full story about Bendix, its products and employment opportunities.

### BENDIX AVIATION CORPORATION

Fisher Building • Detroit 2, Michigan

A Bendix representative will be at your campus soon. Make a note now to talk with him. Check your placement bureau for time and date.



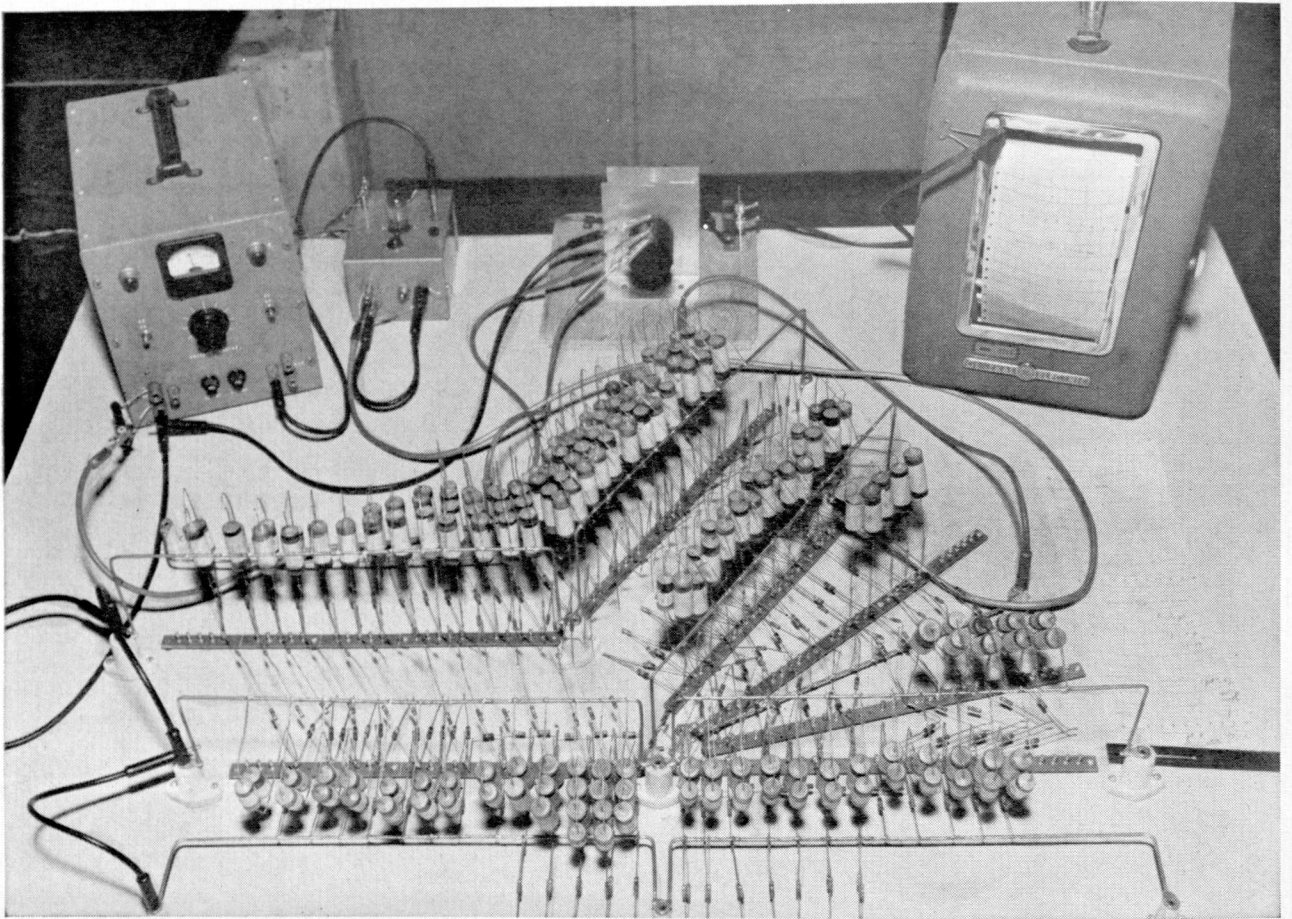

This analogue computer, a pioneer in this age of "thinking machines", was developed by Standard Oil scientists.

## New Electronic "Engineer" Solves Tough Refinery Problem

THE MEN who design modern oil refineries need specific information about temperature distributions in different parts of pressure vessels. Such information, essential to safety and efficient operation, is often extremely difficult to obtain by conventional mathematical methods.

Scientists at Standard Oil's Whiting laboratories recently developed and built an electrical analogue capable of simulating specific conditions within a refinery unit still in

the design stage. Using this device, they could determine in advance the temperature distribution in the joint between two pressure vessels having a common head. Thus they were able to duplicate in 20 seconds the heat stress picture within the unit during an 8 hour start-up to shut-down period.

Creative scientific thinking made possible this constructive achievement by engineers who have chosen to build their careers at Standard Oil.

### Standard Oil Company

910 South Michigan Avenue, Chicago 80, Illinois



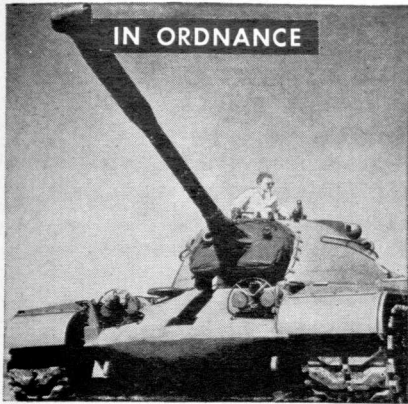

## HONEYWELL OFFERS DIVERSIFIED OPPORTUNITIES

THE opportunities for engineers in the automatic control field are unique in their variety and in the insight provided into all of the industries of today's modern world.

The development and manufacture of tiny transistors for electronic control . . . the design and manufacture of quality electronic photo flash units . . . the challenge of finding fish with underwater sonar . . . of providing automatic flight for supersonic jets . . . temperature controls for today's modern home . . . for atomic piles . . .

These are a few of the fields in which Honeywell's several divisions are engaged, providing automatic controls for industry and the home.

These controls are made possible by the creative imagination of highly trained engineers working with the very latest research and test facilities.

With twelve separate divisions located throughout the United States and with factories in Canada, England and Europe, Honeywell offers unlimited opportunities in a variety of challenging fields. Based on diversification and balance between normal industry and defense activities, Honeywell will continue to grow and expand because automatic control and instrumentation are so important to the world's progress.

That is why we are always looking for men with ideas and imagination and the ambition to grow with us. In addition to full time engineering and research employment we offer a Cooperative Work Study program, a Summer Student Work Study program and Graduate Fellowships. If you are interested in a career in a vital, varied and diversified industry, send the coupon for more information.

MINNEAPOLIS  
**Honeywell**



*First in Controls*

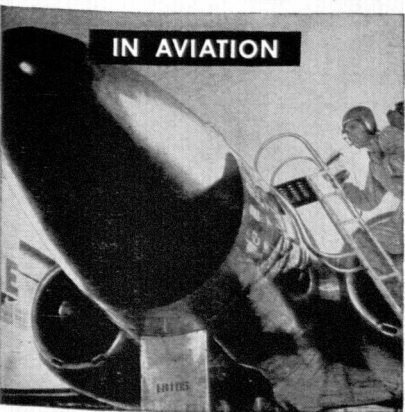
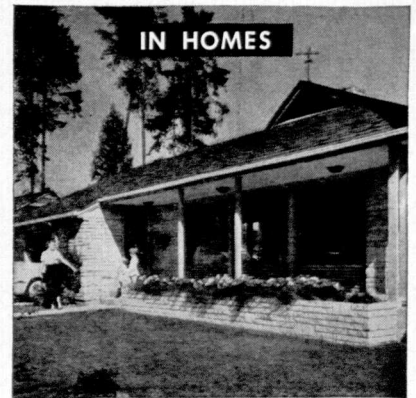
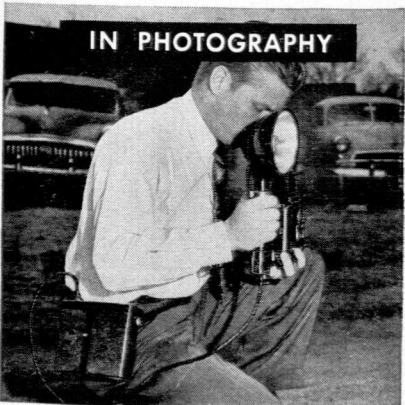
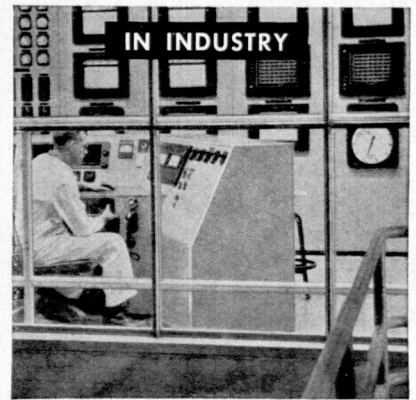
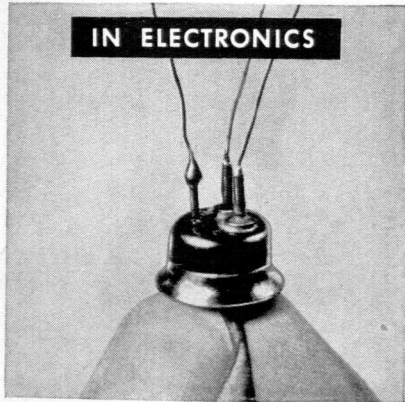

MINNEAPOLIS-HONEYWELL  
REGULATOR Co.  
Personnel Dept., Minneapolis 8, Minn.

Gentlemen: Please send me your booklet, "Emphasis on Research", which tells more about engineering opportunities at Honeywell.

Name .....

Address .....

City .....

Zone ..... State .....

Division: Appliance, Aeronautical, Commercial, Doelcam, Heating Controls, Heiland, Industrial, Marine, Micro Switch, Ordnance, Transistor, Valve.

## Clubs and Societies

(Continued from page 9)

### ASAE

Again this year the Agricultural Engineers are sponsoring a Micro-Midget Auto Race during the Engineering Exposition. They are following the tradition they started last year and hope to make it an annual event.

This year's race will follow the same general pattern as last year's original race with only a few alterations. Circle Drive again has been designated as the official track. Two separate "heats" are being planned for this year's race in contrast to the single event of last year. The tentative plan is for the first heat to be at 10:30 A.M. on Saturday, May 14. The second heat will follow at 2:30 P.M. in the afternoon.

The various engineering societies are showing a growing interest in the race. Seven societies have now entered cars. This is expected to be the maximum number. There is much to indicate that this year's race will be even more exciting than the previous one.

The cars will be much the same as the originals. A few changes in the specifications have been made. These include the addition of: positive drive steering and rear wheel brakes capable of locking while the car is in motion. A body covering the entire car is also required.

The safety rules are more strict now than before. All cars must be equipped with safety belts and roll-over bars. Crash helmets will be worn by all drivers during the race. These precautions should largely eliminate the possibility of an injury if any of the cars are involved in a mishap.

The power unit consists of a two horsepower Reo Royale motor. They are being furnished by Motor Wheel. The clubs have agreed to 4:00 x 8 wheels for their cars. They will then become a permanent part of the car and eliminate redesigning problems from year to year.

### New Developments

(Continued from page 17)

horsepower hour) of a piston engine is roughly equivalent to a gas turbine engine in the major area of helicopter operation, the premium gasoline required by a piston engine costs two and one-half times as much as the gas turbine fuel. The reason why a piston engine does not show a great specific fuel consumption advantage is that a helicopter is unique among aircraft since most of its normal operation is a full or nearly full power. The S.F.C. of a piston engine increases at high power levels, while the S.F.C. of the gas turbine decreases as power increases and is at its best at full power.

Because the turbine wheel attempts to extract every last bit of energy from the gas stream and convert it to shaft horsepower it has the effect of being a muffler. For this reason, gas turbine engine will be less noisy than an equivalent piston engine.

The T-58 is a gas turbine engine for helicopters which will be about the size of an automobile engine but many times as powerful.

Gas turbines for helicopters are similar to jet engines. Replace the tailcone on a jet engine with turbine wheel that can extract energy from the hot gas stream and you have a gas turbine that could power a helicopter.

Primarily an air breathing engine, a hypothetical gas turbine rated at 1250 horsepower would breathe approximately 14 pounds of air per second or 10,400 cubic feet per minute. An average man in an average day breathes approximately one cubic foot of air per minute so it would take at least 10,000 people to blow the required hot air through the little one and one-half foot diameter turbine wheels of this engine for one minute of operation.

Typical compressor blade for such an engine would weigh about one fifth of an ounce but it spins so fast during engine operation that it would feel as if it weighed one half of a ton. The merry-go-round ride that it gets on a compressor wheel multiplies its weight about 75,000 times.

### New Type of Speedometer

A new disc type speedometer, known as the "Safety Arc," which indicates speed by a continuous curved red line, is now in production.

Besides being unusually attractive, the new speedometer design has a decided safety feature. While the speedometer is compact, speed is clearly indicated by a bold red line on a semi-circular dial. The continuous red line flows from left to right across the speed markings as the car accelerates. In decelerating, the line flows back toward zero.

The brilliance of the line, both day and night, gives the driver two quick indications of his speed. First he notes the speed as indicated by the figures at the end of the red line. Second, the length of the line itself is an automatic indication of speed.

Research and experimentation has proven that the bright red 'flowing' line is the most impressive way yet discovered of indicating car speed. Since the speed line lengthens with the increase of car speed, its length tends to make a driver more speed conscious at all times. The total mileage meter is located away from the "speed line" for clear reading of both speed and mileage.

Incorporated in the design of the new speedometer are directional signal indicators and bright light beam indicators.

### Magnesium

(Continued from page 15)

magnesium forms about 2½% of the earth's crust and is the sixth most abundant chemical element. The amount of magnesium potentially available in the oceans of the world staggers the imagination, for even a single cubic mile of sea water contains more than 6,000,000 tons.

Magnesium—Metal from the Sea— is indeed a fine tribute to the technical skill of American scientists and engineers.

Donald C. Pote asks:

What bearing  
would my field  
of training have  
on my assignments  
at Du Pont?

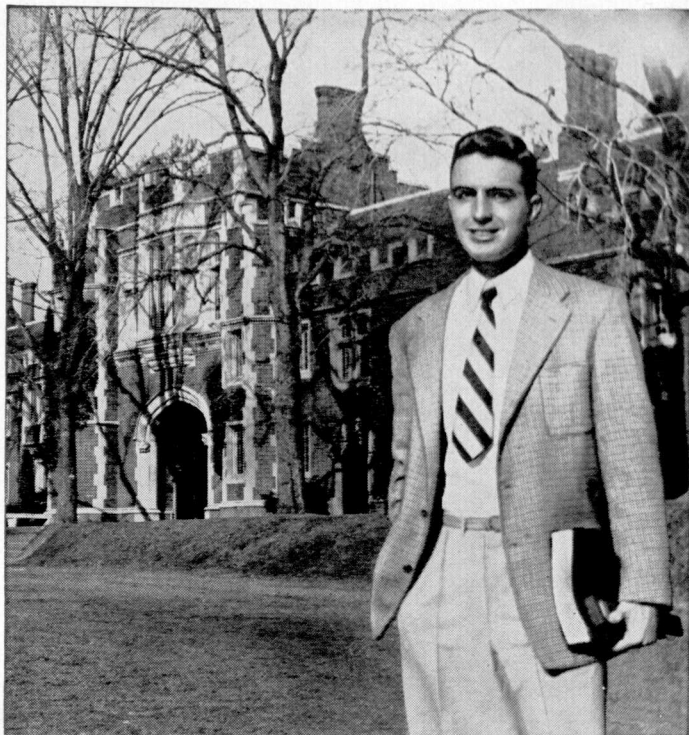

**DONALD C. POTE** will receive his B.S. degree in Mechanical Engineering from Princeton University this June. He's been quite active in interclub athletics—football, basketball and baseball—and served a term as Club Athletic Director. He's also found time to work on "The Princeton Engineer" as Associate Editor. Right now, Don is making thorough plans for his employment after graduation.



**CHARLES H. NOREN** received his B.S. in Mining Engineering from the University of North Dakota before he entered the U. S. Air Force. Later he returned to school for an M.S. from the Missouri School of Mines, received in 1948. During the course of his Du Pont employment, Chuck Noren has had a wide variety of job assignments. At present he is engaged in a fundamental research project concerned with commercial explosives at Du Pont's Eastern Laboratory in Gibbstown, N. J.

"Chuck" Noren answers:

The answer to that is easy, Don, if you mean *initial* assignments. Generally speaking, a graduate's first assignment is influenced by his previous training and his expressed interest in a particular type of work. Whenever possible, Du Pont assigns a man to the type of work he is trained for and wants—he'll do better in any field if he's highly interested. For example, my master's thesis was on the use of explosives, and my first Du Pont assignment was a study of the efficiency of explosives.

But experience on the job really constitutes *new training*. You learn about other branches of science and engineering—you broaden your horizons through daily contacts with men having other skills. The result is that arbitrary divisions between technical branches gradually dissolve, and you become ready for new assignments and new responsibilities—even outside your original field. In my own case, I developed quite a bit of skill in mechanical and civil engineering techniques when I was called upon to supervise the "shooting" of an experimental tunnel for the evaluation of new explosives—even though my original training was in mining engineering.

Of course, specialization in a definite field may be continued if the man specifically wants it and reveals a talent for it. The best opportunities for that are in research and development. Naturally, the value of this kind of work is also recognized at Du Pont.

So, no matter what your initial assignment may be, Don, Du Pont is anxious to bring out your best. A good rule to remember is this. A graduate's *first* assignment is often necessarily based on his field of training and his degree, but his subsequent progress at Du Pont is *always* based on his demonstrated ability.

**NOW AVAILABLE** for student ASME chapters and other college groups, a 16-mm. sound-color movie—"Mechanical Engineering at Du Pont." For further information write to E. I. du Pont de Nemours & Co. (Inc.), 2521 Nemours Bldg., Wilmington 98, Delaware.



REG. U. S. PAT. OFF.

BETTER THINGS FOR BETTER LIVING . . . THROUGH CHEMISTRY  
WATCH "CAVALCADE OF AMERICA" ON TELEVISION





1928—Engineers calculating development problems

1955—Solving complex engineering problems with Boeing computer

## The best research facilities are behind Boeing engineers

The Boeing-designed electronic computers shown above solve in seconds problems that once required weeks—typical of the advanced “tools” that help Boeing engineers stay at the head of their field.

Boeing engineers enjoy such other advantages as the world’s fastest, most versatile privately owned wind tunnel, and the new Flight Test Center—the largest installation of its kind in the country. This new Boeing Center includes the latest electronic data reduction equipment, instrumentation laboratories, and a chamber that simulates altitudes up to 100,000 feet. Structural and metallurgical research at Boeing deals with the heat and strain problems of supersonic flight. Boeing electrical and electronics laboratories are engaged in the development of

automatic control systems for both manned and pilotless aircraft. Other facilities include hydraulic, mechanical, radiation, acoustics, and rocket and ramjet power laboratories.

Out of this exceptional research background engineers have developed such trend-setting aircraft as America’s first jet transport, and the jet age’s outstanding bombers, the B-47 and B-52. Research means growth—and career progress. Today Boeing employs more engineers than even at the peak of World War II. As the chart shows, 46% of them have been here 5 or more years; 25% for 10, and 6% for 15.

Boeing promotes from within and holds regular merit reviews to assure individual recognition. Engineers are

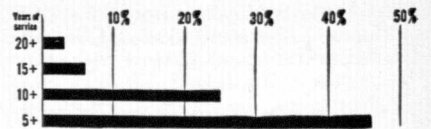

encouraged to take graduate studies while working and are reimbursed for all tuition expense.

There are openings at Boeing for virtually all types of engineers—electrical, civil, mechanical, aeronautical and related fields, as well as for applied physicists and mathematicians with advanced degrees.

For further Boeing career information consult your Placement Office, or write:

JOHN C. SANDERS, Staff Engineer — Personnel  
Boeing Airplane Company, Seattle 14, Wash.

**BOEING**

SEATTLE, WASHINGTON WICHITA, KANSAS

Spartan Engineer

# The Torrington Needle Bearing

*proper housing design is essential to proper performance*

The Torrington Needle Bearing offers many design and operational advantages for a great variety of products and equipment. For example, a Needle Bearing has greater rated radial load capacity in relation to its outside diameter than any other type of anti-friction bearing. It is extremely light in weight. And it is easy to install and lubricate.

## *Housing Maintains Bearing Roundness*

The housing is an essential part of the Needle Bearing assembly. Care should be taken to provide a straight, round housing bore to the recommended tolerances.

The thin, surface-hardened outer shell of the Needle Bearing acts as the outer race surface as well as a retainer for the rolls. This shell assumes the shape of the housing into which it is pressed. Consequently, the housing bore should be round, and the housing so designed that it will carry the radial load imposed on the bearing without distortion.

## *Housing Material Determines Bore Size*

The specified housing bore dimensions for any given material should be maintained in order to give the proper running clearance

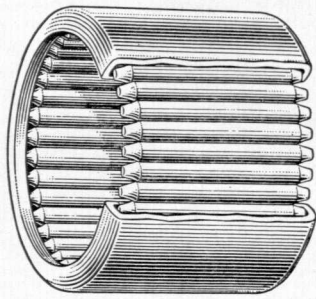

*Needle Bearings require simple housings. If the housing bores are held to proper size, accurate operation and high radial capacity are assured.*

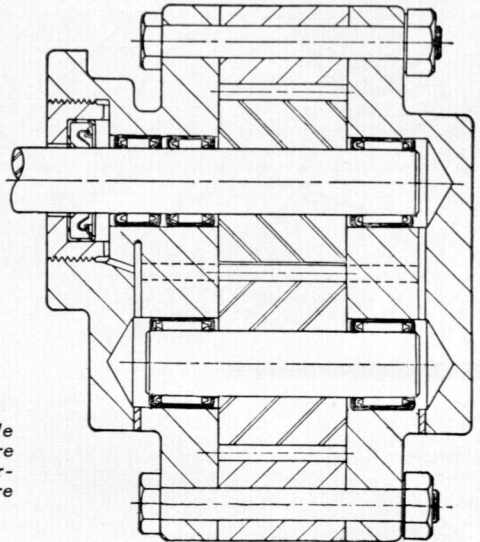

HYDRAULIC PUMP

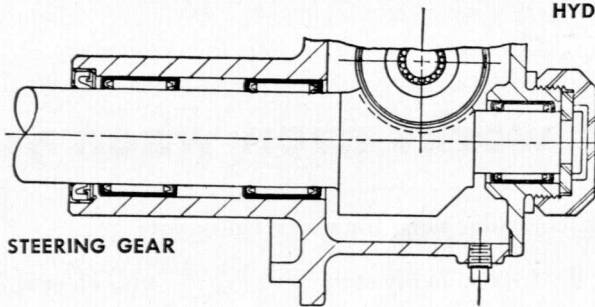

STEERING GEAR

between the needle rollers and the shaft, and to assure sufficient press fit to locate the bearing firmly.

When designing housings of materials that are soft or of low tensile strength, allowance should be made for the plastic flow of the material when the bearing is

pressed into place. Bore dimensions in such cases should be less than standard. Needle Bearings can be pressed directly into phenolic or rubber compounds, although metal inserts are recommended.

The new Needle Bearing catalog will be sent on request.

### THE TORRINGTON COMPANY

Torrington, Conn. • South Bend 21, Ind.

District Offices and Distributors in Principal Cities of United States and Canada

# **TORRINGTON NEEDLE BEARINGS**

NEEDLE • SPHERICAL ROLLER • TAPERED ROLLER • STRAIGHT ROLLER • BALL • NEEDLE ROLLERS



## **water works even when you're asleep!**

*This particular need for water isn't acute.*

But if . . . as so many students have . . . you elect the challenging field of Sanitary Engineering for your future, you'll come up against many more problems of supplying, distributing, maintaining an adequate supply of water for homes and industries in a thirsty world.

Here, you can count on the help of one valuable ally . . . cast iron pipe. Practically every city in America—large or small—uses it for water and gas mains . . . and over 60 of them have been served by cast iron pipe for a century or more.

On its record, cast iron pipe is Man's most dependable carrier of water.

**CAST IRON PIPE RESEARCH ASSOCIATION**

Thos. F. Wolfe, Managing Director, 122 So. Michigan Avenue, Chicago 3, Ill.



**CAST IRON PIPE SERVES FOR CENTURIES**

## Cylinder from Mars

(Continued from page 11)

All this he stated with some pride in the fact that practically all the data he related were twice as long as ours. He continued, "The canals which were seen by Schiaparelli in 1877 really are there. We travel them in atomic-powered boats. What your scientists think is barren desert is in reality a large prairie with Marrms, our main source of food."

After he was through reciting, I felt like he was the traveling agent for the Mars' chamber of commerce. Then, he presented me with a pamphlet containing all kinds of data that I couldn't begin to decipher.

I asked the colonel about the many weird things I had just heard and seen. He said, "It is accomplished with mathematics, my dear, simply mathematics. Someday you will understand that there is only one formula needed to understand the entire workings of the universe."

After this, he explained how they had been observing the earth for quite some time, and so I ventured to ask him about the future of the earth.

"You people must learn to get along with each other," he said. "What does it matter which type of government, whether the legislative power is a congress, parliament, poletariate, or a king and queen who reign? The way you govern is not the important thing, but how you govern. It should be for the benefit of all, not just a few. You must get rid of prejudice and hatred toward others; nations should intercede to help each other, not recede from their duties."

I asked him how such things could be accomplished, and he replied that each planet had its own problems to work out. "Mars was the same way, but we have been around a few more eons than the earth. We are glad to see you making progress, but we hope you won't direct it into the wrong channels."

I wish I could have had more time to talk to these fascinating creatures, but the colonel explained that they had important business and must leave immediately to arrive home on schedule.

As they rose straight up into the atmosphere, I stood in awe, for I had never seen anything rise like that from the earth before. I was thinking that I must be the only one ever to see anyone from another world.

The foremost thought in my mind then was all the pertinent questions I had forgotten to ask in my excitement, such as: how they knew English; why I had been their candidate, or had it been just by chance; how did they rule their planet; did they believe in a God, if so what kind; what were the mysteries of the universe which they seemed to understand; and how did they find all of these things with one mathematical equation? Perhaps the reason I forgot to ask was that such mysteries cannot be told, but must be learned by doing. Experience is the best teacher.

Because this planet we call earth is in such a jumble at the present, I thought I'd pass along the experience I had. Many of you won't believe this, for I hardly believe it myself, but I swear it really happened!

**Seventh  
Annual**

**ENGINEERING  
EXPOSITION**

★

**May 12, 13, 14**



Now is the time to get the  
**LIFE-LONG  
CASTELL  
HABIT!**

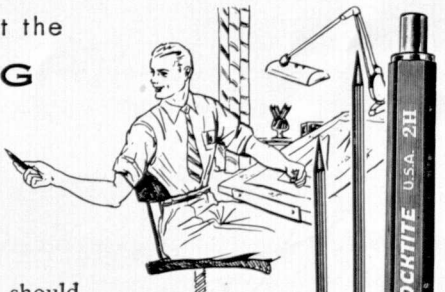

Your tools of tomorrow should be your tools of today. When you graduate and start upon your own career you will find that the top engineers, architects and designers use CASTELL—either the famous wood pencil or LOCKTITE Holder with 9030 lead.

CASTELL is smoother, stronger, lays down greater depth of graphite on the drawing. It is uniformly excellent in all 20 degrees, 8B to 10H.

You study in a fine school, taught by outstanding professors. Does it make sense to work with inferior tools? Order CASTELL, world's standard of quality, from your College Store, stationer or art supply store.

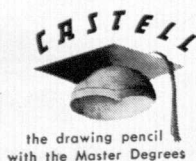

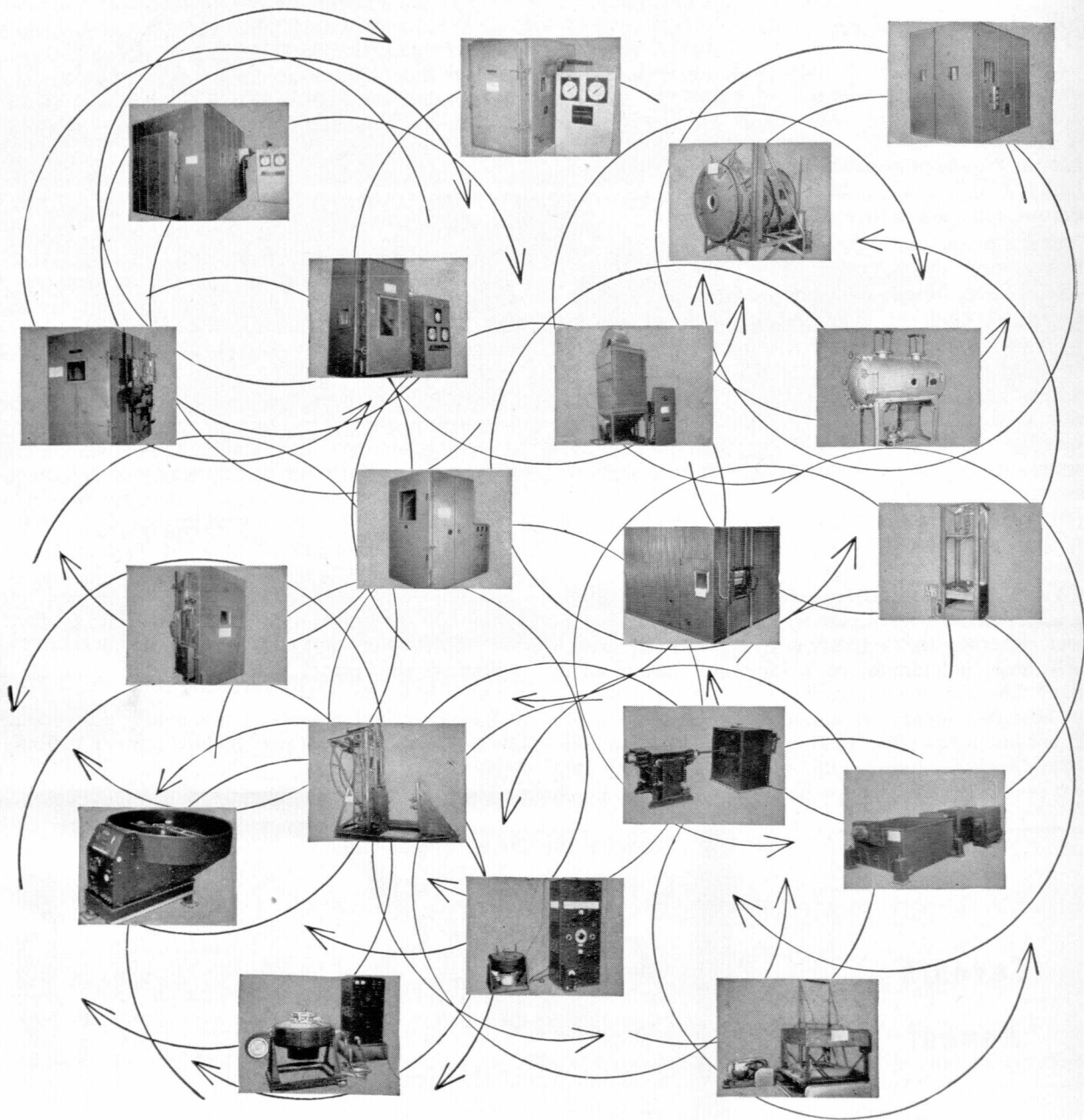

## 19 chambers of hell

You are looking at the units of a \$2,000,000 Martin testing laboratory—part of a man-made hell of fire and water, shock and vibration, explosion and corrosion, designed to torture *electronics equipment!*

For these vital components of today's aircraft, guided missiles and weapons systems must carry tremendous responsibilities. Consider, for example, the electronic system of the Martin B-61 Matador:

Incredibly versatile, it comprises the entire brain and nervous system of America's first successful pilotless bomber. Yet this sensitive equipment must withstand

the shock of many tons of thrust in the first second of take-off—violent changes in temperature and pressure—and ground conditions ranging from sand storms to arctic blizzards, desert dryness to tropical downpour.

Today, Martin's facilities are among the finest in the world for design, production and proving in the field of avionics...one of the major developments of Martin Systems Engineering which is now tailoring airpower to previously impossible requirements.

*You will hear more about Martin!*

**MARTIN**  
BALTIMORE · MARYLAND



Spartan Engineer

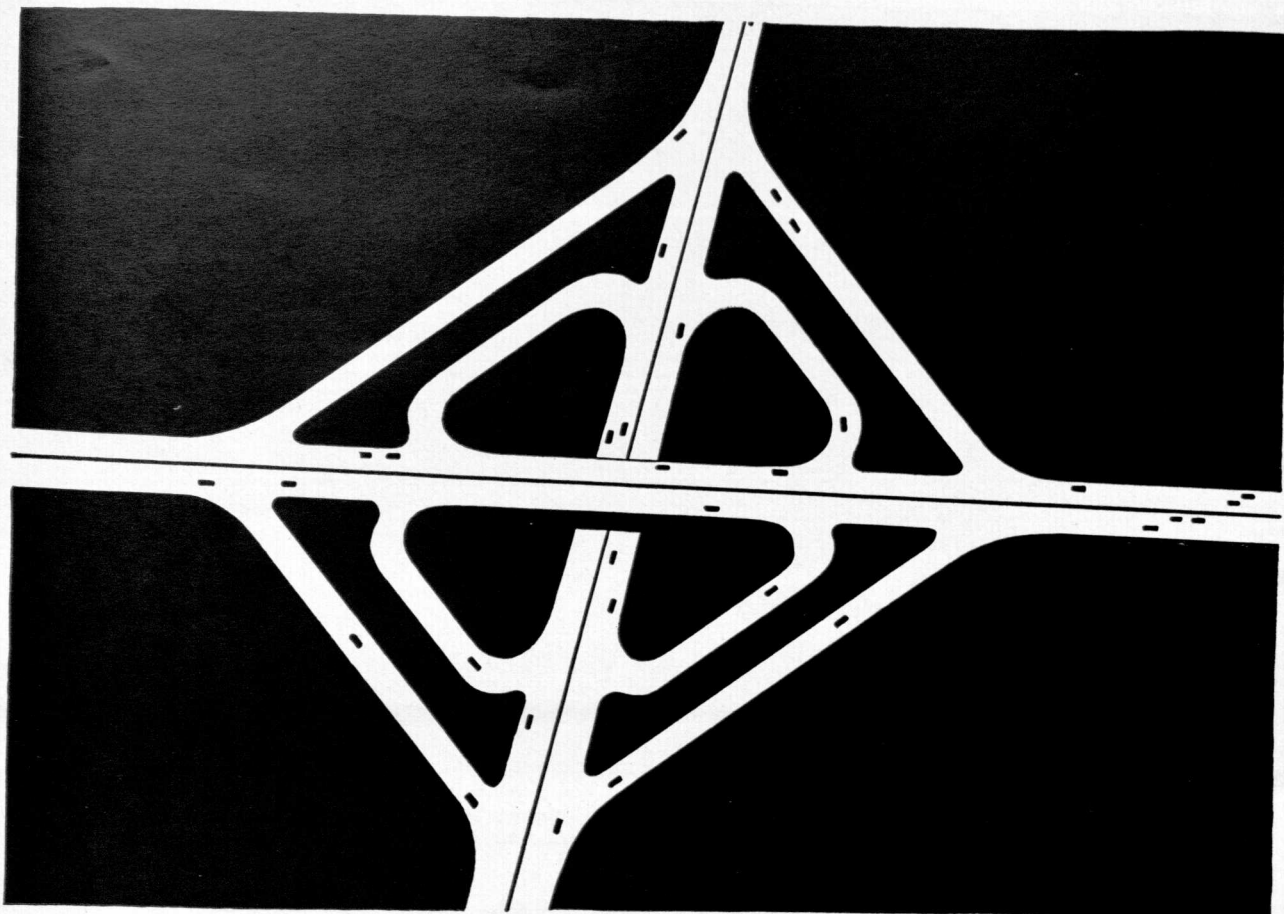

### FROM COW-PATHS TO CLOVERLEAFS...

The narrow, twisting, rut-ridden roads of yesteryear are being replaced by new multi-lane, high-speed highways. Crossroads have been bridged and cloverleafed... hills have been leveled... curves lengthened.

These changes have happened in the half century since the advent of the automobile. For more and better cars and trucks demand faster, safer roads and turnpikes.

### SPACE FOR SPEED...

The traffic that flows over America's three-million mile network of roads represents the very life stream of our progress. Nowhere else in the world do people travel so far and so freely... nor do so many trucks deliver such a wide and plentiful supply of merchandise so fast and to so many places.

### AMERICA WORKS LIKE THAT...

Here in America we have men who dare to dream and build for future needs... machines to move mountains... materials to make roads... and an all-seeing, all-hearing, and reporting Inter-Communications System that acquaints every branch of science and engineering... every technical skill... with the needs and the accomplishments of every other field of endeavor.

### THE AMERICAN INTER-COM SYSTEM...

Complete communication is the function, the unique

contribution of the American business press... a great group of specially edited magazines devoted to the specialized work areas of men who want to manage better, research better, sell better, buy better.

### COMMUNICATION IS OUR BUSINESS...

Many of the textbooks in which you are now studying the fundamentals of your specialty bear the McGraw-Hill imprint. For McGraw-Hill is the world's largest publisher of scientific and technical works.

After you leave school, you will want to keep abreast of developments in your chosen profession. Then one of McGraw-Hill's many business magazines will provide current information that will help you in your job.

# McGRAW-HILL

## PUBLISHING COMPANY, INC.



330 WEST 42nd STREET  
NEW YORK 36, N. Y.



HEADQUARTERS FOR TECHNICAL AND BUSINESS INFORMATION

**... ENCOURAGE LEADERSHIP**



▲ **LEARN BY DOING**—Each year thousands of boys and girls learn how to become better farmers and better citizens through 4-H Awards Programs, such as the Entomology Program sponsored by Hercules. Top awards are college scholarships. Hercules' interest in improved farming methods stems from its development of agricultural chemicals, notably toxaphene for insecticides.

# HOW HERCULES HELPS...

Most businesses are helped today by Hercules' business . . . the production of synthetic resins, cellulose products, chemical cotton, terpene chemicals, rosin and rosin derivatives, chlorinated products, and many other chemical processing materials—as well as explosives. Through close cooperative research with its customers, Hercules has helped improve the processing or performance of many industrial and consumer products.

**STANDARD MODELS** and plastic-bodied sports cars alike rely on nitrocellulose lacquers for durability and beauty. In the manufacture of these polyester laminates, such as this car door, Hercules hydroperoxides act as the catalyst in their polymerization.



**... DRESS UP AUTOS**

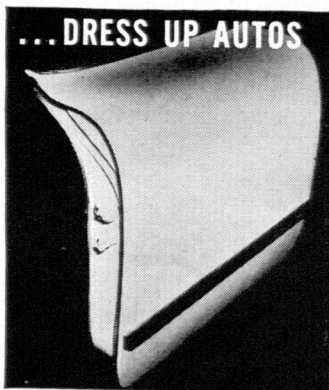

**... MAKE WASHDAY EASIER**



▲ **WHITER, BRIGHTER CLOTHES**—Hercules® CMC is a key ingredient in detergents . . . suspends soil, prevents its redeposition on clothes. This excellent property of suspension enables Hercules CMC to serve in a variety of consumer and industrial products.

**HERCULES**

**HERCULES POWDER COMPANY**  
INCORPORATED

Wilmington 99, Delaware. Sales Offices in Principal Cities.

# "I needed to 'Find' Myself— that's why I picked Allis-Chalmers,"

says **A. J. MESTIER**

*Massachusetts Institute of Technology Sc. B.—1943  
and now Manager, Syracuse District Office*

"I WAS LOOKING for an engineering job, but I wasn't very sure just what phase of this broad field would interest me most. I didn't know whether I wanted straight engineering, sales engineering, production or some other branch of industrial engineering.

"Allis-Chalmers Graduate Training Course gave me a means of working at various jobs—seeing what I liked best—and at the same time obtaining a tremendous amount of information about many industries in a very short time."

## Experience Typical

"My experience is typical in many ways. I started the Graduate Training Course in 1946, after three years in the Army. My first request was to go to the *Texrope* V-belt drive department. From there I went to the Blower and Compressor department; then the Steam Turbine department. By the time the course was completed in 1948, my mind was made up and I knew I wanted sales work. I was then assigned to the New York District Office and in 1950 was made manager of the Syracuse District. The important thing to note is that all Allis-Chalmers GTC's follow this same program of picking the departments in which they want to work.

"Best of all, students have a wide choice, for A-C builds machines for every basic industry, such as: steam and hydraulic turbine generators, transformers, pumps, motors and other equipment for electric power; rotary kilns, crushers, grinders, coolers, screens and other machinery for

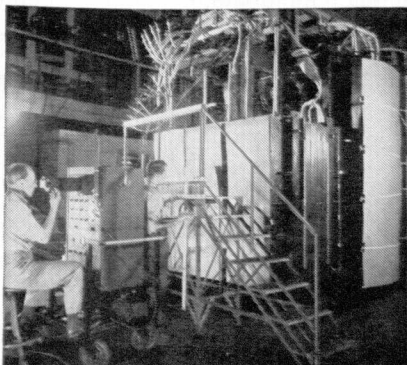

**Taking** surge voltage distribution tests on power transformer in A-C shops with miniature surge generator and cathode-ray oscilloscope.



mining, ore processing, cement and rock processing. Then there is flour milling machinery, electronic equipment and many others."

## A Growing Company

"In addition, new developments and the continuing growth of the company offer almost endless opportunities for young engineers.

"From my experience on the Graduate Training Course, I believe it is one of the best conducted in the industry and permits a young engineer to become familiar with a tremendous variety of equipment—both electrical and mechanical—which will serve him in good stead in his future profession."

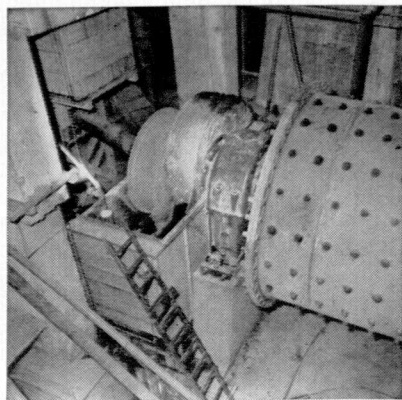

**Ball Mill** grinds ore for large copper producer. Same type of equipment from Allis-Chalmers pulverizes much of nation's cement.

*Texrope* is an Allis-Chalmers trademark.

# ALLIS-CHALMERS

For information call the Allis-Chalmers District Office in your locality or write to  
Allis-Chalmers Manufacturing Company, Milwaukee 1, Wisconsin





## Generator-Type Dynamometer

(Continued from page 19)

rotate, but is held in position by a projecting arm which is attached to a scale by the same method used in the illustrated dynamometer. Some means must be provided for transferring the rotary motion of the rotor to that of the stator, so that the torque can be measured. Also, this transfer must be made without friction. By winding a coil of wire around a portion of the stator and passing an electric current through it, the stator becomes magnetized. This magnetism passes through the rotor and tends to keep it from revolving. However, when the rotor is revolved, it sets up Eddy currents which in turn set up a counter magnetic force. This, then acts as a magnetic coupling between the rotor and the stator and tends to cause the stator to revolve with the rotor. Since the stator is held in a stationary position by the scale connection, the measurement of torque is obtained. The power from the engine or motor under test is transmitted to the rotor of the dynamometer, which in turn, by means of magnetism, imparts the power to the stator where it is measured in pounds upon the dynamometer scale. From the torque calculated and the speed of the rotor, the horse-power of the test engine may be obtained. The flow of Eddy currents causes heating which must be removed by a suitable cooling system in the stator. Dynamometers of this type are very flexible in their operation and may be adapted to a large range of conditions. They are especially useful in the measuring of high speed devices such as turbines due to their solid cast rotors. They can also be made to produce extremely high torques at low speeds, as well as offer a smooth adjustable range of torques.

Since the operation and theory of the most common types of dynamometers has been briefly covered, the following discussion will pertain only to the construction of the illustrated dynamometer.

The first system used to dissipate the electrical energy was eight 200 watt, 110 volt light bulbs. This would have been sufficient to absorb the power output of the  $1\frac{1}{2}$  horsepower engine, but as the generator was capable of producing only 40 volts, the bulbs could not absorb their rated wattage. Then eight 660 watt, 110 volt heating elements were used. These worked well for the engine performance test, but did not give the pictorial representation of the mechanical action of the dynamometer necessary for class demonstrations which could be obtained by the use of light bulbs. After an extensive search, a company was located which could obtain, by special order, 30 volt light bulbs. One dozen, 100 watt, 30 volt bulbs were ordered and delivered. These will be used when the dynamometer is displayed at the 1955 Engineering Exposition.

After the first test run, it was found that only a small speed variation of 965 to 1300 R.P.M. resulted in the motor shaft speed, depending upon the addition or removal of the external resistors. This was due to the characteristics of the differentially compound wound 40 volt generator. In a generator of this type, the shunt winding produces a field which is in opposition to that of the series winding. Due to this arrange-

ment, the maximum voltage output is at low loads and as the load increases, the voltage decreases rapidly. This allows the generator to maintain relatively constant speeds at all loads, which is exactly reverse of the characteristics desired in a dynamometer. It was then assumed, from information obtained in *Electric Motors*, by Rosenburg, that if a variable resistance could be placed in the shunt winding of the generator, the desired range of speeds could be attained. The first attempt was to place a 1.65 amp, 300 ohm, variable resistor in series with the shunt winding. This gave the desired speed range, but the resistor could not handle the amount of current flowing in the circuit.

An ammeter placed in the circuit registered 4.5 amps. This amperage necessitated either the purchase of an \$18.00 variable resistor or a change in the wiring diagram to allow the use of the 1.65 amp resistor. The latter was decided upon, and the variable resistor was placed in parallel with two 660 watt 110 volt, 18.2 ohm heating elements and this total system was placed in series with the shunt winding. Under this system, the maximum equivalent resistance of the parallel wiring was 9.1 ohms, and as long as the variable resistor was not operated in the range from .001 to 14.9 ohms, not more than 1.65 amps of current would flow through the coils of the variable resistance. The above values are theoretical and under actual practice, the resistor coils did not seem to greatly overheat, even when operated in the range from .001 to 14.9 ohms. Under test conditions, it was not found necessary to operate the resistor in this critical range to obtain the desired speed. By varying the resistance, which in turn changed the generator's field intensity, it was possible to vary the speed range of the motor, at wide open throttle, from 965 to 2,280 R.P.M., the generator load remaining constant.

The large amount of vibration produced by the 1.5 H.P., one cylinder internal combustion engine made it necessary to measure the shaft R.P.M. from the generator armature, rather than the engine crankshaft. The readings taken at the armature would correspond to one-half the engine R.P.M., as the engine power shaft runs from the cam and not the crankshaft.

The scales used to measure the force exerted on the generator stator had a maximum range of ten pounds, subdivided to permit reading to 1/100 of a pound, and possessed a vibration dampener which enabled more accurate readings to be obtained.

Some may argue that special problem courses which are offered by all the major engineering departments do not contribute as much to ones education as courses which are specifically designed to teach a principle in one field of engineering. However, in a course of this nature, a student is able to compile and use information from many courses previously taken in his chosen field of engineering. Also, research, as one must do in industry, is of prime importance in obtaining data necessary for the successful completion of the project. Being proficient in obtaining and applying engineering principles is one of the most important qualities an engineer can possess, and no easier method of obtaining these qualities exists than through actual practice in a special problem course.

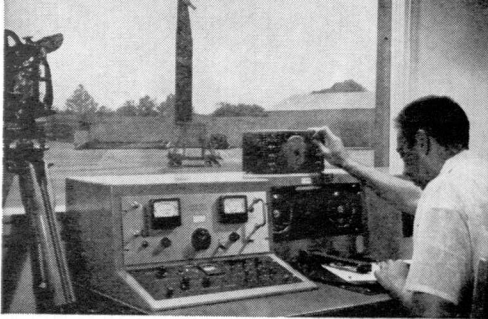

Electronics Research Engineer Irving Aine records radiation antenna patterns on Lockheed's Radar Range. Twenty-two foot plastic tower in background minimizes ground reflections, approximates free space. Pattern integrator, high gain amplifier, square root amplifier and logarithmic amplifier shown in picture are of Lockheed design.



Jim Hong, Aerodynamics Division head, discusses results of high speed wind tunnel research on drag of straight and delta wing plan forms with Richard Heppie, Aerodynamics Department head (standing), and Aerodynamicist Ronald Richmond (seated right). In addition to its own tunnel, Lockheed is one of the principal shareholders in the Southern California Cooperative Wind Tunnel. It is now being modified for operation at supersonic Mach numbers.



Research Engineer Russell Lowe measures dynamic strain applied by Lockheed's 500,000 lb. Force Fatigue Machine on test specimen of integrally-stiffened Super Constellation skin. The Fatigue Machine gives Structures Department engineers a significant advantage in simulating effect of flight loads on a structure. Among other Lockheed structures facilities are the only shimmy tower in private industry and largest drop test tower in the nation.



C. H. Fish, design engineer assigned to Lockheed's Icing Research Tunnel, measures impingement limits of ice on C-130 wing section. The tunnel has a temperature range of  $-40^{\circ}\text{F.}$  to  $+150^{\circ}\text{F.}$  and maximum speed of more than 270 mph. It is the only icing research tunnel in private industry.

## Advanced facilities speed Lockheed engineering progress

Lockheed's unmatched research and production facilities help make possible *diversified* activities in virtually all phases of aviation, military and commercial.

They enable engineers to test advanced ideas which would remain only a conversation topic in firms lacking Lockheed's facilities. They help give designers full rein to their imagination. They make better planes — and better careers.

Engineering students interested in more information on Lockheed's advanced facilities are invited to write E. W. Des Lauriers, Lockheed Student Information Service, Burbank, California.

# Lockheed

AIRCRAFT CORPORATION  
BURBANK California

# Problem:

## DESIGN DRIVE FOR MAGNETIC TAPE "MEMORY" OF IBM 705 ELECTRONIC COMPUTER. SPECIFICATIONS:

1. Tape speed: 75 in./sec.
2. Dead stop to operating speed in .005 sec. or less.
3. Complete interchangeability of tapes and recording heads.
4. Tape loading: semi-automatic. (No threading through guides or heads.)

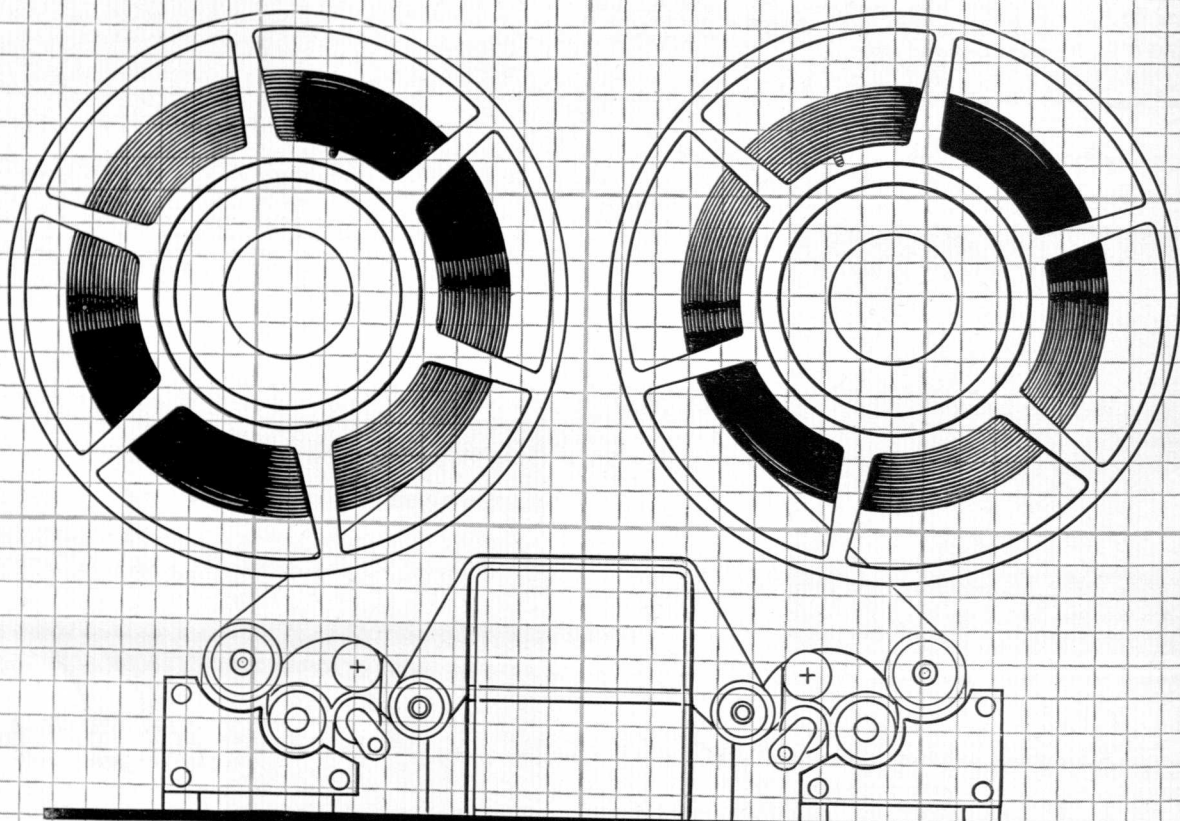

# Solved—by IBM's Mechanical Engineers!

This is the kind of problem that constantly challenges IBM engineers.

It challenges their knowledge, their skill, and their ingenuity. It challenges them to "throw away the book" and, starting from scratch, come up with solutions that are unorthodox—both in concept and execution.

In this stimulating atmosphere, the young engineer quickly discovers that fresh new ideas are not only in demand, but are given the chance to pay off in practical application.

No doubt about it: The man with imagination, versatility, and enthusiasm can look forward to a bright and virtually unlimited future—at IBM!

### M.E.'s, E.E.'s, and Engineering Physicists!

Whatever interests you most—research, development, product design, or manufacturing—IBM offers you a challenging and rewarding career!

For a picture of IBM's Engineering Laboratories in action, ask your placement officer for the new 32-page booklet, "Opportunities Unlimited." Or write Mr. W. M. Hoyt, Engineering Recruitment Office, IBM, 590 Madison Ave., New York 22, N.Y.

# IBM

TRADE-MARK  
INTERNATIONAL BUSINESS MACHINES



○ Another page for

## YOUR STEEL NOTEBOOK

### How to make a boring job go faster

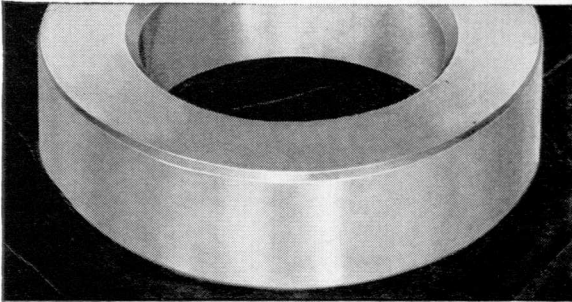

With teeth cut into it, this gear blank becomes an engine part. One manufacturer thought these blanks were costing him too much to make. The center hole had to be bored out of solid bar stock. It took one hour to make 29 blanks. A lot of steel was wasted in the process. He took his problem to Timken Company metallurgists. After study, they recommended a change in production methods together with the use of Timken® seamless steel tubing.

### How TIMKEN® seamless tubing helped quadruple production

○ Because the hole's already there in Timken seamless tubing, it doesn't have to be bored out. No steel is wasted. Finish boring is now the manufacturer's first step. He can turn out 120 to 130 gear blanks per hour with a 50% cut in machining costs. This is another one of the hundreds of problems that have been solved by Timken fine alloy steel.

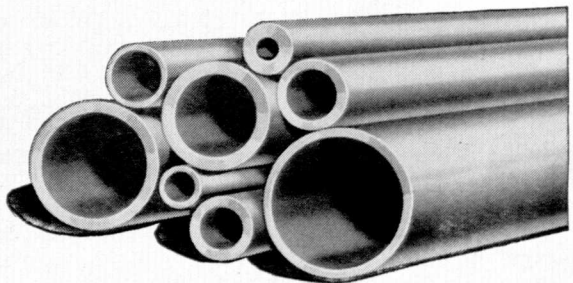

### Want to learn more about steel or job opportunities?



Some of the engineering problems you'll face after graduation will involve steel applications. For help in learning more about steel, write for your free copy of "The Story of Timken Alloy Steel Quality".

And for more information about the excellent job opportunities at the Timken Company, send for a copy of "This Is Timken". Address: The Timken Roller Bearing Company, Canton 6, Ohio.

YEARS AHEAD—THROUGH EXPERIENCE AND RESEARCH



**TIMKEN**  
TRADE-MARK REG. U.S. PAT. OFF.  
**Fine Alloy**  
**STEEL**

SPECIALISTS IN FINE ALLOY STEELS, GRAPHITIC TOOL STEELS AND SEAMLESS TUBING

**L**      **A Successful**  
**A**      **Stamping Service**  
**N**      **to Industry**  
**S**      **Since 1914**

**S**  
**T**  
**A**  
**M**  
**P**  
**I**  
**N**  
**G**  
**C**  
**O**  
**.**

*Serving*  
*Manufacturers of*  
**AUTOMOBILES**  
**AGRICULTURAL**  
**EQUIPMENT**  
**INDUSTRIAL**  
**EQUIPMENT**  
**DOMESTIC**  
**EQUIPMENT**  
**LAWNMOWERS**  
**1159 Pennsylvania**  
**Avenue**  
**Lansing, Michigan**

## The Transistor

(Continued from page 23)

Electrical and physical features of the transistor make it extremely desirable. Perhaps the transistor's greatest electrical advantage is that it does not require a heater filament. This feature decreases the amount of power necessary for operation. The absence of a heater filament also insures instantaneous operation because it is not necessary to heat a cathode. The amount of power necessary to operate some transistors is extremely small. One type of transistor, the junction transistor, can amplify electrical signals a million times, but requires only one millionth of the power of the smallest electron vacuum tube. If you chew a piece of blotting paper, wrap it moist around a 25-cent piece, then clip wires to this combination; it makes a battery strong enough to work a transistor. A transistor can operate on one millionth of a watt. Another big advantage is that some transistors, even available today, are expected to work for 90,000 hours, which is about ten years. The transistors' best physical feature is their small size. Smallest models of the transistor are 1/10" long and 15/100" in diameter.

There are two main types of transistors in use today, the point contact and the junction transistors. The transistors differ in physical appearance and also in the way they use the properties of germanium to achieve amplification. The point contact transistor (Fig. 1) is the older of the two types. It usually consists of a single pellet of germanium with two cat-whisker contacts spaced a few thousandths of an inch apart on the germanium surface. Its high current gain and its high frequency capabilities make it extremely desirable. Bell Laboratories now have a point contact transistor that will operate at 440 megacycles. This is higher in frequency than any transistor yet known and is well into the Ultra High Frequency range used by FM radio and television. The junction transistor resembles a sandwich in that it consists of germanium wafers arranged in certain sequences. The junction transistor has low input power requirements and is capable of high power gain. Also, the noise factor for this transistor is low.

The transistor was made commercially available only five years after its discovery. One of the first places it was used was in the hearing aid. Manufacturers produced these transistor hearing aids, but the transistor proved ineffective because body heat and moisture hampered the effectiveness of the germanium. Improvements have been made to overcome these difficulties and today they are highly effective in the hearing aid. A 15-cent battery will provide power for 400 hours in today's transistor hearing aids.

Home television sets, utilizing tiny transistors about the size of pencil erasers instead of a large array of vacuum tubes, are now a stronger possibility as a result of new developments. The transistors capability of operating on small amounts of power may speed their appearance in automobiles and portable radios. In the future, rockets and guided missiles will be able to carry electronic equipment that is now too heavy and fragile because of the vacuum tube. If the transistor continues to develop at the rate it has developed thus far, it should become a widely used replacement for the vacuum tube in the not too distant future.



## New RCA Radar "Weather Eye" Sees Through Storms

In our time, Man has won round after round in a contest against the elements that started thousands of years ago.

The most recent scientific victory is something new in Radar—an electronic "Weather Eye" developed by RCA.

In airplanes, this supersensitive instrument peers miles ahead. It gives advance warning of weather disturbances. The signals on its radar screen point the way to a safe course *around* storm areas, or even *through* them.

The leadership in electronic research that made the "Weather Eye" possible is inherent in all RCA products and services. And at the David Sarnoff Research Center of RCA, Princeton, N. J., scientists are continually at work to extend the frontiers of "Electronics for Living."

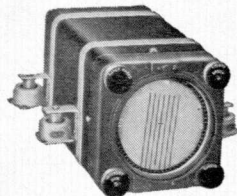

New RCA Weather Mapping Radar weighs under 125 pounds, takes little space in a plane.

For information regarding design and development engineering positions on such projects as "Weather Eye" Radar and military electronic equipment—write to Mr. Robert Haklisch, Manager College Relations, Radio Corporation of America, Camden 2, N. J.



**RADIO CORPORATION OF AMERICA**  
ELECTRONICS FOR LIVING

**E. E. or  
PHYSICS  
GRADUATES**

*with experience in*

**RADAR or**

**ELECTRONICS**

*or those desiring to enter  
these areas...*



Hughes-equipped  
Convair F-102  
all-weather  
interceptor.

*The time was never  
more opportune than now  
for becoming associated  
with the field of  
advanced electronics.  
Because of military  
emphasis this  
is the most rapidly  
growing and promising  
sphere of endeavor  
for the young electrical  
engineer or physicist.*

SCIENTIFIC AND  
ENGINEERING STAFF

**HUGHES**  
RESEARCH AND  
DEVELOPMENT  
LABORATORIES

Culver City,  
Los Angeles County,  
California

Relocation of applicant must  
not cause disruption of  
an urgent military project.

Since 1948 Hughes Research and Development Laboratories have been engaged in an expanding program for design, development and manufacture of highly complex radar fire control systems for fighter and interceptor aircraft. This requires Hughes technical advisors in the field to serve companies and military agencies employing the equipment.

As one of these field engineers you will become familiar with the entire systems involved, including the most advanced electronic computers. With this advantage you will be ideally situated to broaden your experience and learning more quickly for future application to advanced electronics activity in either the military or the commercial field.

Positions are available in the continental United States for married and single men under 35 years of age. Overseas assignments are open to single men only.

## Index To Advertisers

- 39 Allis-Chalmers
- 21 Allison Division, General Motors
- 7 Aluminum Co. of America
- 16 Babcock & Wilcox
- 24 Bendix Aviation
- 32 Boeing Airplane
- 34 Cast Iron Pipe Research Assoc.
- 14 Columbia Southern Chemical
- 1 Detroit Edison
- 4 Dow Chemical
- 31 E. I. duPont de Nemours
- 35 A. W. Faber-Castell Pencil
- 26 Federal Telecommunication Lab.
- 10 General Motors
- 36 Glenn L. Martin
- 38 Hercules Powder
- 46 Hughes Aircraft
- 42 International Business Machines
- 16 Keuffel & Esser
- 44 Lansing Stamping
- 41 Lockheed Aircraft
- 37 McGraw-Hill Publishing
- 29 Minneapolis-Honeywell Regulator
- 20 New Departure Division,  
General Motors
- 18 Pittsburgh Plate Glass
- 13 Pratt & Whitney Aircraft
- 45 Radio Corporation of America
- 28 Standard Oil
- 6 Sylvania Electric Products
- 43 Timken Roller Bearing
- 33 Torrington Needle Bearing
- 47 Western Electric
- 21 Westinghouse Electric
- 2 Worthington
- ° United States Steel
- °° Eastman-Kodak
- °°° General Electric

\*Inside front cover  
\*\*Inside back cover  
\*\*\*Back cover

# AUTOMATION at work

How a revolutionary new design was translated into a production reality

One of Western Electric's automatic production lines used in making the revolutionary new wire spring relay.

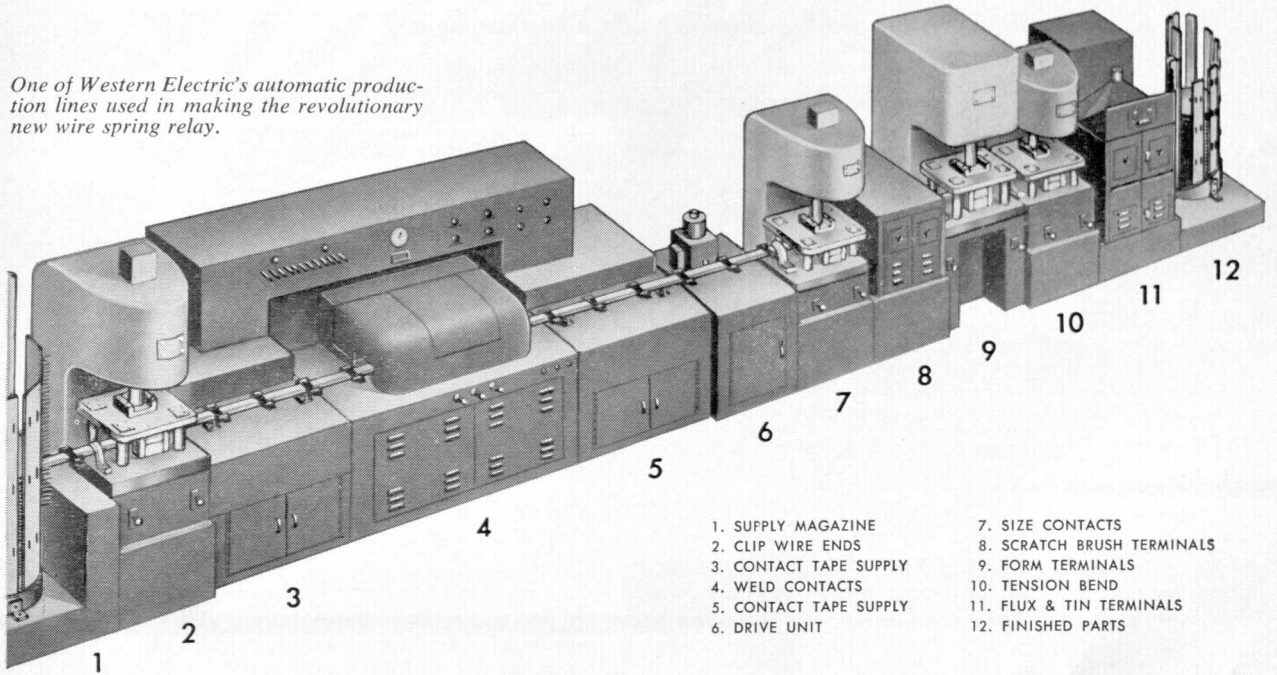

- |                        |                            |
|------------------------|----------------------------|
| 1. SUPPLY MAGAZINE     | 7. SIZE CONTACTS           |
| 2. CLIP WIRE ENDS      | 8. SCRATCH BRUSH TERMINALS |
| 3. CONTACT TAPE SUPPLY | 9. FORM TERMINALS          |
| 4. WELD CONTACTS       | 10. TENSION BEND           |
| 5. CONTACT TAPE SUPPLY | 11. FLUX & TIN TERMINALS   |
| 6. DRIVE UNIT          | 12. FINISHED PARTS         |

So great was the departure in design of the new Bell System wire spring relay as compared with conventional relays that it posed a major undertaking for development engineers at Western Electric, the manufacturing and supply unit of the Bell System. Indeed, it was an undertaking that called for new machines and new methods because none was available to do the job.

Longer life, higher operating speed, lower power consumption, and lower manufacturing cost were some of the advantages promised by the new relay design. Engineers reasoned that a lower manufacturing cost could be achieved through greater precision in manufacture (which would cut adjustments) and through extensive use of automatic processes.

One of the products of this reasoning is pictured at the top of this page. This battery of equipment, developed by Western Electric product engineers, constitutes one phase of wire spring relay manufacture, which automatically performs several separate operations. Its function begins after one of the fundamental elements of the new relay has been fabricated. This element, known as a "comb," consists of a multiplicity of small diameter wires in parallel array imbedded for part of their length in molded phenol plastic.

These molded elements, of which there are two types used in the new relay, are delivered to this line of machine units in magazines. By fully automatic means they are removed from the magazine, carried by a reciprocating conveyor through each of the several processes and, when completed, placed into another magazine to await further assembly.

Between the first and final magazine the automatic battery of equipment does the following operations: clips wire ends, attaches palladium contacts to wire ends by means of percussion welding, sizes contacts, forms terminal, tension bends wires, fluxes and tins terminals.

Most remarkable of all is the fact that this is a *precision* operation throughout. For example, the small block con-

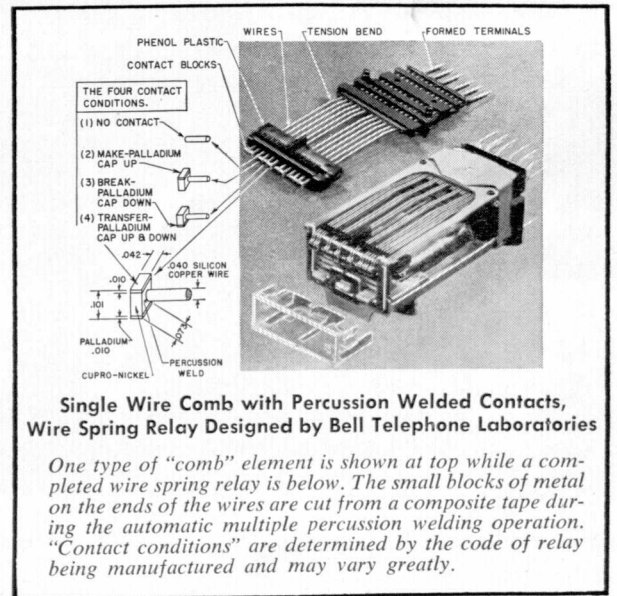

Single Wire Comb with Percussion Welded Contacts, Wire Spring Relay Designed by Bell Telephone Laboratories

One type of "comb" element is shown at top while a completed wire spring relay is below. The small blocks of metal on the ends of the wires are cut from a composite tape during the automatic multiple percussion welding operation. "Contact conditions" are determined by the code of relay being manufactured and may vary greatly.

tacts, which are percussion welded to the tips of wires of one type of "comb," must be located on the same plane across the twelve contact positions to within a tolerance of  $\pm .002$ ".



Manufacturing plants in Chicago, Ill.; Kearny, N. J.; Baltimore, Md.; Indianapolis, Ind.; Allentown and Laureldale, Pa.; Burlington, Greensboro and Winston-Salem, N. C.; Buffalo, N. Y.; Haverhill and Lawrence, Mass.; Lincoln, Neb.; St. Paul and Duluth, Minn. Distributing Centers in 29 cities and Installation headquarters in 15 cities. Company headquarters, 195 Broadway, New York City.



# Crossword for Engineers

By Ray Steinbach and Ed Champagne

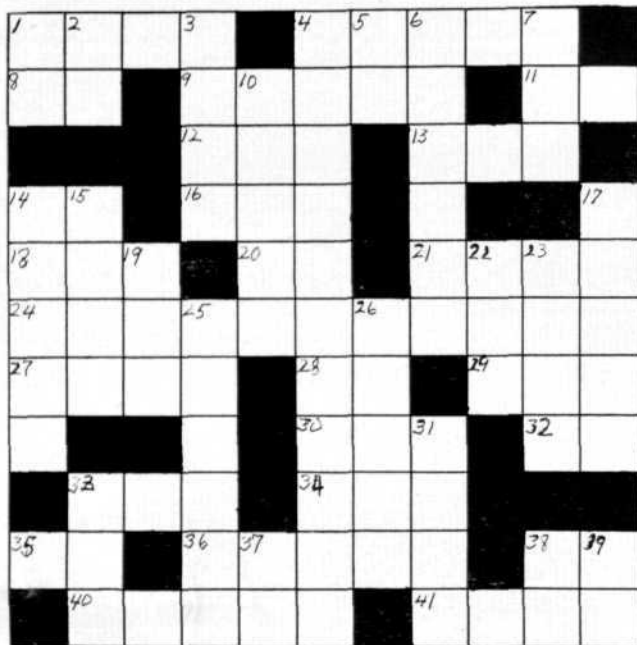

FILL SPACES WITH NUMBERS

## ACROSS

1. joules per calorie
4. one atmosphere
8. coefficient of expansion of Cu
9.  $x^3 - 12x^2 - 10x + 46$  when  $x$  equals 50
11. density of steel
12. sine of 45 degrees
13. cos of 32 degrees
14. 19th prime number
16. thermal conductivity of brass
18. heat of vaporization of water
20. lbs. per kg
21. 2 to the twelfth plus 3 to the seventh plus 4 cubed plus 972
24.  $\_ d^2 = C$
27. feet per mile
28. atomic No. of Holmium
29. radians in 38 degrees 50 min.
30. log 2
32. LXV
33. boiling pt. of water
34. cm. per in.
35. boiling pt. of Hg
36. sq. meters per sq. yd.
38. 1/6 gross
40. cos 22 degrees
41. 7/16

## DOWN

1. atomic No. of Cb
2. density of O
3. atomic wt. of element 31
4.  $\frac{1}{2}$  of 24 across
5. ft. per sec. equals 30 MPH
6. ln 80.1
7. BTU per HP
10. 13/32
14. grams per lb.
15. cot of 16.8 degrees
17. inches in .05 meters
19. antilog of .8872
22. cube root of 16 to the sixth
23. ft. lbs. per joule
25. log 10 to the 87th plus 10 to the 5th
26. drams per c.c.
31. index of refraction of flourite
33. specific heat of glass
37. atomic weight of P
38. density of Al
39.  $\_ - \sin x = \cos x$

## ANSWER TO JANUARY PUZZLE

