

Extension Bulletin 773
Farm Science Series



• THE SMALL POULTRY FLOCK



THE SMALL POULTRY FLOCK

by C. C. Sheppard, Cal J. Flegal and Thomas Thorburn

So you want to keep a few chickens. Do you want to keep broiler chicks for meat production or egg-type chicks or started pullets for egg production? Success in raising poultry depends on many things. The three most important are: **proper feeding, sound management and good sanitation.** Of course, genetically well-bred birds capable of high production are a prerequisite to good management.

BABY CHICKS FOR EGG PRODUCTION

Selecting Chicks

- Buy from a reputable hatchery. (A directory of hatcheries is available from Michigan Allied Poultry Industries, Box 858, East Lansing, Michigan 48823.)
- Buy healthy chicks from a U.S. Pullorum-Typhoid Clean hatchery.
- If possible, work closely with the person from whom you buy the chicks. If you are new in the poultry business, the hatcheryman can help you.
- Select the breed or strain for the purpose intended. **There is no really good dual purpose chicken.** There are broiler strains and egg-laying strains of chickens.
- Neighbors who have had good results may give you the name and address of the hatchery where they buy chicks.
- Almost 100% of the egg-laying strains of birds sold in Michigan lay white eggs (they are Leghorn-type birds). Brown egg-laying strains are available. Remember: there is no difference between white and brown shelled eggs — except for the shell color — if the birds are cared for in the same manner.

Getting Ready for New Chicks

- Remove all equipment possible, such as: feeders, waterers, brooders, etc., from the house.
- Wash all equipment with a soap or detergent and rinse thoroughly. If possible, place in the sun to dry — this will help disinfect the equipment.
- Remove used litter and rubbish from the house, such as: bags, paper, tools, buckets, etc.
- Clean the building thoroughly — sweep ceilings,

¹The authors are: Professor, Extension Specialist, and Associate Professor in the Department of Poultry Science, and Extension Agricultural Agent, Lapeer, Michigan, respectively.

walls, remove and wash windows, remove any caked material on the floor.

- Use a high pressure sprayer to completely wash down the building interior or soak caked materials to loosen them. Apply an approved insecticide in buildings where lice, mites, beetles or other insects have been a problem.
- Use a good rodent control program inside and outside of the building.
- Rinse equipment with a disinfectant. Quaternary ammonium and chlorine bleaching agents are good disinfectants. Follow instructions on the container.
- Put clean, dry litter in the building after it has been cleaned, disinfected and dried. Chopped straw, wood shavings or crushed or coarsely ground corn cobs make good litter.

Brooder Stoves for Chicks

You must provide heat for the baby chicks. Brooder stoves are available that use gas and oil. These stoves have hovers that contain or retain the heat close to the floor. Electric heat lamps (without hovers) are also used to brood chicks.

- Start the brooder stove at least 24 hours before the chicks arrive to properly adjust the stove and dry out the house.
- Provide a temperature of 90-95° F at chick level. Use only new or cleaned chick guards at least 2-3 feet from edge of brooder hover for first 7 days. Use solid chick guards in cold houses.
- A chick guard is a paper, cardboard or a fine wire mesh ring around the heat source (brooder stove) that confines the birds to the warmed area.
- Reduce temperature under the hover gradually over a period of weeks. It is good to have heat under the hover and have the rest of the pen or house cool. Chicks will gradually learn to regulate their location in the temperature zone most comfortable for them.
- Over a period of several weeks (outside temperature will make a difference) gradually raise the brooder hover or heat lamps. Birds should gradually become accustomed to the idea that the heat source is not necessary. Remember, the brooder has been a foster mother to them.
- Chicks indicate when they are too cold or too warm. When too cold, they chirp — complain a lot; when too hot, they will lay down or try to pile in corners. When comfortable, young chicks form a ring on the floor under the heat source.

Litter

The purpose of litter is to provide comfort, and absorb droppings and excess moisture.

- Use clean, dry, dustless litter 2-3 inches deep on concrete or wood floors. **Dirt floors are not to be used as it is impossible to clean and disinfect them.**

- Remove wet and caked spots in the litter immediately; replace with dry litter.

- Day-old (and up to a week old) chicks may eat the litter instead of the feed. Cover the litter with rough paper or egg filler flats to prevent litter eating. When the birds are eating the feed well, remove the paper (slippery paper may cause leg problems).

Feeding Chicks

- Use freshly-made feed; do not buy more than a month's supply of any feed, as feeds tend to deteriorate with age.

- Start chicks on a commercial chick starter purchased from a local elevator or feed dealer. Follow the feed manufacturer's recommendations closely as to length of time each feed should be fed.

- Usually four different rations are fed to egg-type chickens. A 21% protein starter ration is fed for the first 8 weeks. An 18% protein grower ration is fed from 8-14 weeks of age. A 14% protein maintenance ration is fed from 15-20 weeks of age. A laying mash is fed to pullets after 20 weeks of age.

- Grit may be provided in a small box in the house. Gravel — take out the large stones — will provide all of the grit needed for birds of any age. Grit helps grind coarse feed in the gizzard of poultry.

POULTRY HOUSING FOR ALL AGES

A well-constructed brooding and/or laying house should be well-insulated and well-ventilated.

Ventilation

- Provide plenty of ventilation. Good ventilation removes excessive heat, ammonia odors, excess moisture and airborne disease organisms. A small fan with a thermostat is useful for small houses; for large houses, request the poultry housing bulletin listed on the last page of this publication for information.

A small chicken house with ventilation inlet slots between the windows.

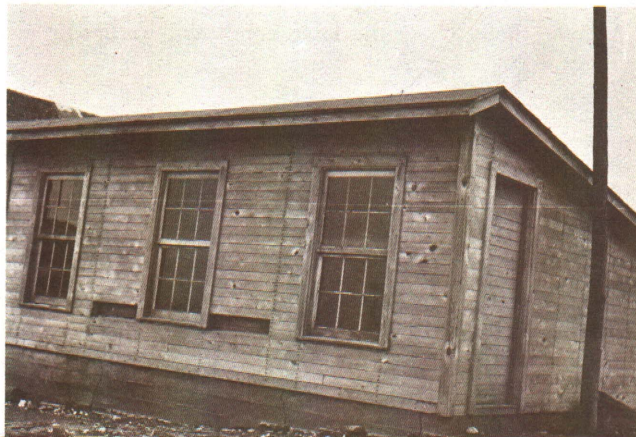

- Do not protect the birds too much — they are usually comfortable at cool to cold temperatures. Adult birds do well in temperatures that range from 0° - 80° F. Avoid freezing the water and rapidly and widely fluctuating temperatures.

- Birds (baby chicks to adult birds) do not like drafts.

Insulation

- To maintain a warm (above freezing) house in winter and a cool house in summer, you must use insulation.

- Three to six inches of fiber glass batts, or equivalent, in the walls and ceiling will provide adequate insulation under most conditions.

- Birds produce heat. The purpose of the insulation is to confine this heat to the house during the cold weather. Large egg production units of 10,000 birds or more can maintain a minimum temperature of 60° F during the coldest Michigan winter months. A small flock of 25 birds will not provide enough body heat to maintain this house temperature. Electric heat tapes on the water pipes and a heat bulb over the waterers may be needed to keep water from freezing in houses with small flocks.

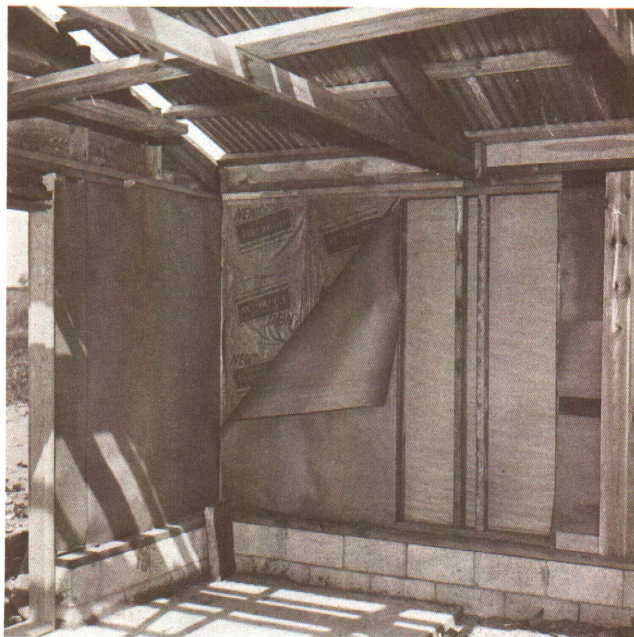

A house under construction showing insulation, vapor barrier and interior sheathing.

SPACE AND EQUIPMENT REQUIREMENTS

- Allow ½ square foot of floor space per chick to 3 weeks of age, 1½ square feet to 14 weeks of age and 1½-2 square feet per hen in well-ventilated and well-insulated houses.

- Allow 40 linear feet of feeder space per 100 hens. You should have enough feeder space so all birds (of any age) can eat at the same time. Feeders and waterers should

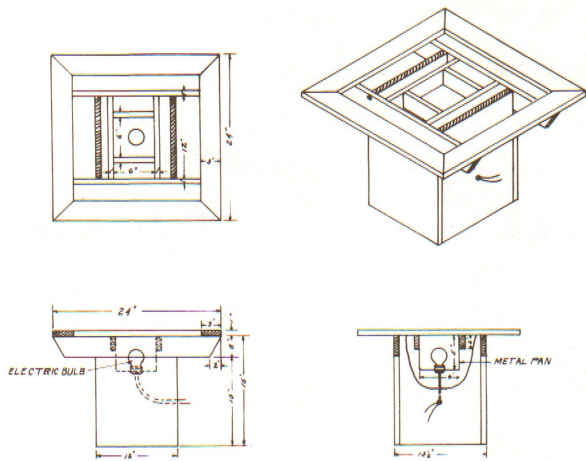

A simple plan for a water stand with light bulb to prevent water from freezing.

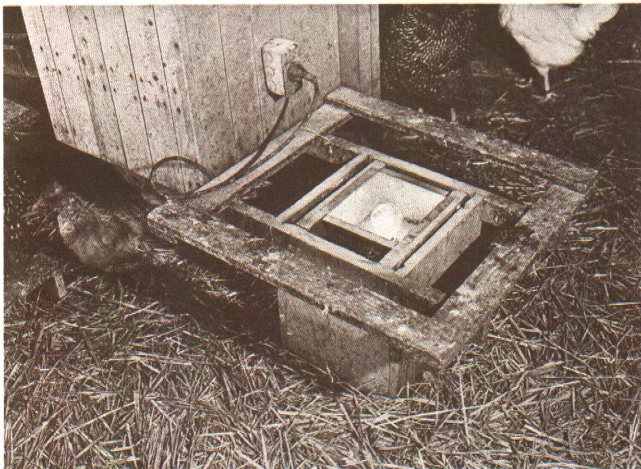

A heated water stand.

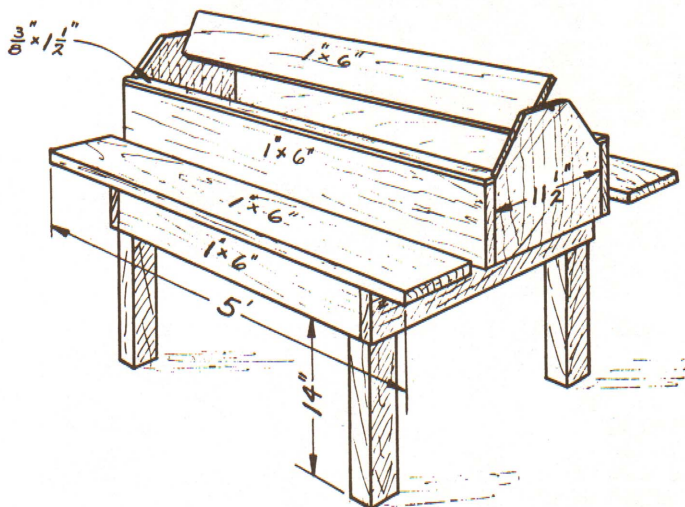

A plan for a small feeder.

be raised as the birds get older. The top of the feeder side should be raised to at least the level of the bird's back as it stands (in a normal position) on the floor. The birds should have to reach up and over the edge of the feeder. This will help prevent feed wastage.

- Allow three ½ gallon water founts per 100 chicks at one day of age. After a week or so, use larger founts so that water intake is unrestricted. Clean founts everyday.

- Allow one 5 gallon water fountain or 4 linear feet of watering trough for each 100 hens. Water is the cheapest nutrient; keep it clean, fresh and always available.

EGG PRODUCTION

So you want to keep a few hens for egg production! Many producers buy 20-week-old started pullets for the laying house. Producers who wish to have a small flock might consider this approach to getting started with some birds.

Other producers might want to contact a commercial egg producer who is selling off his flock of old hens. A few of these hens will do a fine job of laying eggs. You should expect to molt these birds (allow them to replace their feathers — take a rest for 8-10 weeks). They should then come back into production with nice, large eggs.

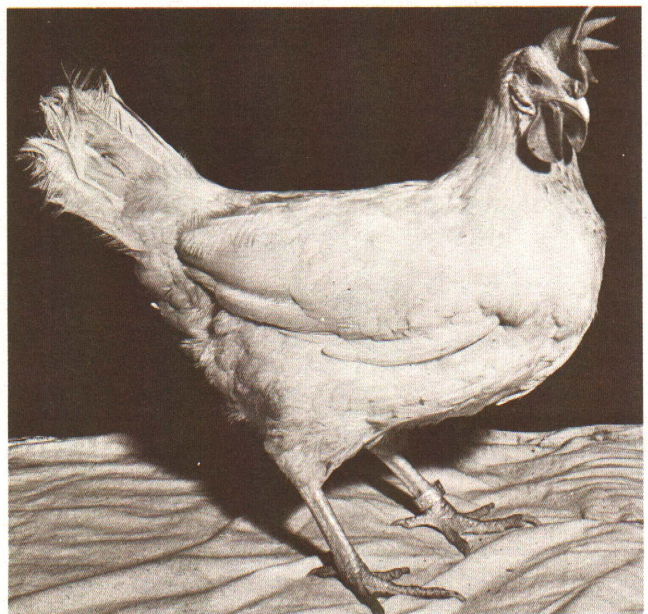

A laying hen. (Note the large comb and wattles.)

Management for Egg Production

- Put new birds in a clean, dry, well-insulated and well-ventilated house.

- Provide plenty of clean, fresh water. Clean water founts daily.

- Provide fresh feed with adequate space for all birds to eat. Do not store feed for long periods of time. Keep feed in a cool, dry place until fed to the birds. A feed designed for layers should be fed. A 16-18% protein laying mash is desirable.

- Keep poultry house clean and well-supplied with clean, dry litter. Used litter that looks dirty (with manure) is clean if it is dry!

- Control rodents.

- Cull non-laying hens! Laying hens have 3-4 inches distance between the pubic bones at the base of the tail (the vent) and the keel bone. They have more than 1 inch of space between the pubic bones (one on each side of the vent). The vent is oval and moist. (Non-layers have much less distance between the pubic bones and the vent is round and dry.)

- Do not allow feed wastage; feeders must be placed at proper height and filled not over half-full.

- Feed according to age and purpose of birds!

- Provide one nest for each 4-5 laying hens. A 2x4 foot community nest will take care of 40 laying hens.

- Light is essential for laying hens. It stimulates egg production and hens will not lay well if kept under conditions of declining light-day length (this occurs from late June until late December).

Pullets (young female chickens) become sexually mature (will lay eggs) at approximately 20 weeks of age. They should be given 16 hours of light (daylight plus electric) per day. Our longest day in Michigan is about 15½ hours. If you give the layers 16 hours of light, you will not be in danger of shortening their day length.

The amount of light needed is not great. One foot candle of light at bird level in the dark part of the house is adequate. A 40-watt bulb each 100 square feet of floor space is more than adequate.

CANNIBALISM

Cannibalism (picking) among chickens is always (at all ages) a distinct possibility. The best way to control this problem is to prevent its start. The actual cause of this problem is not really known. We suspect that too much of something is the cause; too much heat, too much light, crowding and starvation have been blamed.

Control is based on making the birds comfortable. Vary temperatures and light within the house when possible. Allow the birds some light and dark areas in the house. Space requirements are discussed in another part of this publication. Some small flock owners allow the birds to run free; this is good for cannibalism control.

Debeaking is the control (and preventative if done before the birds start) measure that is used if cannibalism gets started. To debeak the bird, remove one-half to two-thirds (when measuring from the

nostril hole to the tip of the beak) of the upper beak and the tip of the lower beak. A pocket knife or small (very sharp) tin snips will do the job. If bleeding occurs sear the tip of the beak with a red hot soldering iron to stop the bleeding. **Caution:** Do not burn the bird's tongue!

WHAT TO DO WHEN DISEASE STRIKES — OR BIRDS DIE!

- When excessive mortality or morbidity occurs, consult a veterinarian immediately.

- Young birds (4 to 10 weeks old) are highly susceptible to coccidiosis. Coccidiosis is a disease of the intestinal tract that is usually transferred through the litter to susceptible birds. Outbreaks can be controlled, if caught early, by cleaning the house every 3 to 4 days — this removes most of the disease-producing organisms before they become mature, infective agents. Another common method of control is to feed rations that contain a coccidiostat until the birds develop immunity at 12-14 weeks of age.

Vaccinating Poultry

Need for Vaccination

In Michigan and some other states, it is imperative that all chickens — breeding and laying flocks — be protected against infectious bronchitis, Newcastle disease, epidemic tremor, fowl pox and Marek's disease. Failure to protect laying hens against these diseases invites disaster in all poultry enterprises. These diseases cause economic loss from mortality, inefficient growth, reduced egg production and low egg quality. Vaccines offer protection against these diseases.

Vaccine Program (see Table 1)

Chicks, at the time of hatching, carry parental (passive) immunity against infectious bronchitis, epidemic tremor and Newcastle disease; this immunity is derived from the egg from which they hatched. Vaccinating chicks during the first week in the brooder house or cage does not stimulate maximum immunity to these three diseases. It is preferable to withhold vaccination until the parental immunity has subsided. However, day-old chicks must be vaccinated against Marek's disease using the turkey herpes virus vaccine.

Vaccination, whenever administered, causes a reaction (stress) in the birds because the vaccine produces a mild form of the disease. It is recommended that the several vaccines be administered separately rather than in combination to reduce the reaction observed 5 to 7 days following administration.

Table 1. Recommended vaccination program for Michigan

Age of Birds	Vaccine	Method of Administration
1 day old	Marek's disease	Individual hypodermic injection
7-10 days	Infectious bronchitis ¹	Drinking water or dust
17-21 days	Newcastle disease ¹	Drinking water, dust or spray
8-14 weeks	Fowl pox	Individual wing-web
10-16 weeks	Epidemic tremor	Drinking water
4 months	Newcastle disease	Drinking water, dust or spray
Booster every 3 months in egg production	Newcastle disease	Drinking water, dust or spray

¹These two vaccines are often administered simultaneously at 10-14 days of age.

Six Virus Diseases

These can be controlled by the use of available, attenuated virus vaccines: 1) infectious bronchitis; 2) Newcastle disease; 3) epidemic tremor; 4) Fowl pox; 5) laryngotracheitis; and, 6) Marek's disease.

Dangers

Vaccines, except for the killed-type of Newcastle disease vaccine, contain living viruses intended to cause a mild form of the disease, thus, developing immunity to field strains of the respective viruses. Actually, the vaccines do cause a systemic reaction. The reaction will be mild if:

- 1) the birds are healthy at the time of vaccination;
- 2) the bird's environment is clean and dry;
- 3) there are no sudden changes in management practices;
- 4) the brooder temperature is maintained (the temperature may be raised 3°-5° F for a few days after vaccination);
- 5) the instructions accompanying the vaccine are followed;
- 6) booster vaccinations are from the same manufacturer as the original vaccine; and
- 7) you follow instructions on the label.

To assure adequate protection from these diseases, it is important that the birds be in good health when vaccinated!

BROILERS

So you want to keep a few broilers for meat production! Broiler chicks differ from egg production chicks. They grow rapidly if cared for properly. Broiler chicks will weigh 4-6 pounds in 8 weeks if they are really a broiler strain (bred to grow fast) and are fed a broiler ration. Since World War II a very large industry has developed in broilers. The U.S. raises approximately 3½ billion broilers a year.

Cultural Practices for Broilers

Follow the same cultural practices in caring for broilers discussed in the baby chicks for egg production portion of this bulletin. Broiler chicks will grow faster and eat more—in a shorter time, than egg production chicks.

Feeding Broilers

A good broiler starting ration should contain 24% protein. If you feed anything less than this, you are not realizing the potential that the broiler is bred to produce. At 5 weeks of age drop back to a broiler finisher feed containing approximately 21% protein. Order the feed well in advance of when you need it as most feed dealers do not carry a stock of broiler feed. Table 2 will give you an idea of how broilers will eat, drink and grow if cared for properly.

MANAGEMENT CHECK-LIST FOR CHICKS

1. **Litter** — Provide 2-3 inches deep of a mold-free absorbent litter.
2. **Chick Guard** — Place 12-18 inch high chick guard (a ring of netting, paper, cardboard, etc.) around the heat source.
3. **Temperature** — Regulate the brooder temperature to the comfort of the chicks.
4. **Floor Space** — Allow 0.5 square feet of floor space per bird the first 3 weeks, and 1 square foot of floor space per bird for the remainder of the growing period.
5. **Ventilation** — There should be enough draft-free ventilation to remove ammonia fumes and keep the litter dry.
6. **Vaccination** — All birds should be vaccinated.
7. **Feeder Space** — Allow 250-300 linear inches (2- to 6-foot 3½ inch deep trough or use 4 tube-type feeders) per 100 birds.

Table 2. Average feed consumption, water consumption and growth rate of broilers

Age in Weeks	Avg. Wgt.	Feed Conversion	Feed Consumption/100 Birds			Water Consumption/100 Birds		
			Daily	Weekly	Cumulative	Daily	Weekly	Cumulative
			pounds			gallons		
1	0.23	0.70	2.3	16	16	0.5	3.5	3.5
2	0.47	1.11	5.0	35	51	1.2	8.4	11.9
3	0.82	1.37	8.5	60	111	2.0	14.4	26.3
4	1.23	1.58	11.7	82	193	2.8	19.6	45.9
5	1.72	1.72	14.4	101	294	3.5	24.5	70.4
6	2.29	1.85	18.3	128	423	4.4	30.8	101.2
7	2.92	1.94	20.5	144	567	4.9	34.3	135.5
8	3.52	2.08	23.8	167	734	5.7	39.9	175.4
9	4.13	2.20	25.4	178	912	6.1	42.7	218.1

8. **Water Space** — Start with three ½ gallon water fountains per 100 chicks.
9. **Light** — Allow the birds a minimum of 12 hours of light per day with a minimum light intensity of 1 foot candle.
10. **Debeaking** — Remove upper beak ⅓ of the distance from tip to nostril openings and detip the lower beak.
11. **Feed Program For Broiler-Type Chicks:**

Age	Protein	Calories/lb	Ca	P
0- 5 weeks	24%	1425-1550	1.0%	0.6%
6- 9 weeks	20%	1425-1550	1.0%	0.6%

Feed Program For Egg-Type Chicks:

Age	Protein	Calories/lb	Ca	P
0- 5 weeks	20%	1250-1400	1.0%	0.6%
6-14 weeks	17%	1250-1400	1.0%	0.6%
15-20 weeks	14%	1200-1400	1.0%	0.6%
12. **Coccidiostats** — Be sure your chick starter contains a coccidiostat, for example, Amprol or Zoalene at the 0.0125% active drug level.
13. **House Preparation** — Remove all litter and manure. Then scrape, scrub and disinfect the house and equipment.
14. **Brooder Space** — Each chick should be allowed a minimum of 7 square inches of brooder space under the hover. For electrical brooders, 10 inches should be provided.

SUGGESTED BULLETINS

1. Michigan Hatchery Directory, published by the Michigan Allied Poultry Industries, Box 858, East Lansing, Michigan 48823.
2. Poultry Housing For Layers, Extension Bulletin 524, MSU Bulletin Office, P.O. Box 231, Michigan State University, East Lansing, Michigan 48824.
3. Vaccination of Poultry, A Mimeograph, Poultry Science Department, Anthony Hall, Michigan State University, East Lansing, Michigan 48824.
4. The following bulletins are sometimes available at your local county extension office (through county agricultural agents), the Poultry Science Department at Michigan State University or the Superintendent of Documents, U.S. Printing Office, Washington, D.C. 20402 (price 20¢), Stock number 0100-2431.
 - a. Farm Poultry Management, Farmers' Bulletin No. 2197, U.S. Department of Agriculture.
 - b. Raising Livestock on Small Farms, Farmers' Bulletin No. 2224, U.S. Department of Agriculture.
 - c. The Chicken Broiler Industry, Report No. 930., U.S. Department of Agriculture.

Those interested in pheasants may wish to request a bulletin entitled, "Managing Gamebirds," Extension Bulletin E-692, MSU Bulletin Office, P.O. Box 231, Michigan State University, East Lansing, Michigan 48824.

PRACTICAL POULTRY FEED FORMULAS¹

(1000 lb. mix)

All-Mash Feeding					
Ingredients	STARTER		GROWER		LAYER
	20% protein	17% protein	14% protein	17% protein	
Corn, yellow, finely ground	542	—	—	—	
Corn, yellow, medium ground	—	547	422	570	
Alfalfa meal, dehyd. 17% protein	25	20	20	25	
Soybean meal, dehulled, 50% protein	—	—	—	—	
Soybean meal, solv. 45% protein	255	160	45	195	
Wheat middlings, standard	50	150	200	90	
Oats, ground	50	50	250	—	
Oat hulls, ground (or fine ground corn cobs)	—	—	—	—	
Meat and bone scraps, 50% protein	25	25	25	20	
Whey, dried	10	10	—	—	
Fish meal 60% protein	15	10	15	10	
Salt	3	3	3	5	
Dicalcium phosphate	5	5	5	15	
Limestone, ground ⁵	15	15	10	65	
Vitamin-trace mineral premix ²	5	5	5	5	
Coccidiostat ³	+	+	+	+	

Calculated Analysis					
Ingredients	STARTER		GROWER		LAYER
	20% protein	17% protein	14% protein	17% protein	
Crude protein	%	20.0	17.0	14.0	17.0
Crude fat	%	3.0	3.3	3.6	3.1
Crude fiber	%	4.8	4.8	6.5	4.2
Productive energy	Cal/lb	875.0	875.0	835.0	890.0
Calcium	%	1.2	1.1	0.9	3.25
Phosphorus (total)	%	0.7	0.6	0.6	0.8
Salt	%	0.3	0.3	0.3	0.5
Manganese (supp.)	mg/lb	28.0	28.0	28.0	28.0
Approximately					
Vitamin A	I.U./lb	3300.0	3100.0	2800.0	3400.0
Vitamin D ₃	I.C.U./lb	700.0	700.0	700.0	700.0
Vitamin E	I.U./lb	4.0	4.4	4.9	4.3
Vitamin B ₁₂	mcg/lb	4.7	4.5	4.7	3.5
Riboflavin	mg/lb	2.6	2.5	2.3	2.1
Niacin	mg/lb	20.0	23.0	24.0	20.6
Pantothenic acid	mg/lb	6.6	6.7	6.6	5.7
Choline	mg/lb	650.0	575.0	520.0	540.0

Mention of commercial products or companies is for informational purposes only and does not imply their endorsement or prejudice against others not mentioned.

¹Modification of formulas: Ground wheat or 39-40 lbs./bu. oats may replace corn if price is favorable. Light fish meals containing (or adjusted to) 60% protein may replace menhaden fish meal. Bone meal or defluorinated phosphate may replace dicalcium phosphate to provide equivalent amounts of calcium and phosphorus.

²Vitamin-trace mineral premixes: All starter or grower mashes can use Nopcosol M-5, layer mashes and layer mash supplement can use Nopcosol M-3, breeder mashes or breeder mash supplement can use Nopcosol M-4 available from the Nopco Chemical Co., Harrison, N.J. (Check manufacturer's recommendations, since Nopco proposed vitamin mixes may be the double potency which will be required at 2½ lbs. per 1000 pound mix.)

(or)

Dawe's Vitafac No. 1 can be used for all starter, grower, and layer mashes and layer mash supplement. Vitafac No. 2 can be used for all breeder mashes and the breeder mash supplement. These premixes are available from Dawe's Laboratories, Inc., 4800 S. Richmond St., Chicago, Illinois 60632.

Similar-type products may be purchased from these and other manufacturers: Peter Hand Co., 1000 North Avenue, Chicago, Ill.; Merck and Co., Rahway, N.J.; Chas. Pfizer and Co., Inc., Terre Haute, Indiana; Specificide Inc., 55263, Indianapolis, Indiana.

³Coccidiostat employed should permit development of immunity in starting chicks and developing pullets. Do not use coccidiostats in breeder-type rations unless manufacturer guarantees safety for breeding birds.

⁴Provide adequate coccidiostat to compensate for the grain portion of the ration.

⁵To supply extra calcium in the mash:

- A. An additional 30 lbs. of whole oyster shell should be added to each 1000 lbs. of all 15% and 17% protein layer and breeder mashes to supply adequate calcium for building normal egg shell strength.
- B. An additional 60 lbs. of whole oyster shell should be added to each 1000 lbs. of the 22% layer or breeder mash to be fed 1:1 with grain.
- C. An additional 120 lbs. of whole oyster shell should be added to each 1000 lbs. of 40% layer or breeder supplement to be fed 1:3 with grain.

To supply extra calcium free-choice:

Limestone may be added in separate hoppers kept before the layers at all times.