

# Greater Economy and Comfort in Heating Michigan Homes

By JESSE M. CAMPBELL, D. J. RENWICK, R. J. WAALKES and  
J. T. ANDERSON



Photograph—Mr. F. D. Mitchell of Lansing, Michigan.

*This picture illustrates the application of fill insulation to the sidewalls.*

MICHIGAN STATE COLLEGE ● EXTENSION SERVICE  
EAST LANSING

*Issued October 1944*  
*First Revision, June 1949*

## CONTENTS

	PAGE
Introduction .....	5
Heat and the Human Body .....	5
Heating Plants or Systems Used in Michigan .....	6
Gravity Warm Air Systems .....	6
Pipeless and Floor Furnaces .....	8
Forced Warm Air Systems .....	9
Hot Water Heating Plants .....	9
Steam Heating Plants .....	9
Heating Stoves .....	11
Radiant Panel Heating .....	11
The Heat Pump .....	14
Distribution .....	17
Advantages and Disadvantages .....	18
Humidity .....	20
What Humidity is Best? .....	21
Condensation in Walls .....	21
Humidifying Methods .....	22
Insulation .....	23
Requirements .....	23
Types of Insulation .....	23
General Benefits of Insulation .....	24
Cost and Savings .....	24
Weatherstripping for Windows and Doors .....	24
Treatment for Bedrooms .....	26
Calking Around Window Frames .....	27
Storm Windows and Storm Doors .....	28
Fuels .....	28
Availability of Fuels .....	28
Coals .....	29
Coke .....	30
Operating Cost Comparisons of Various Heating Systems .....	30
How to Purchase Coal .....	31
How Coal Burns in a Furnace .....	31
Furnace Firing .....	34
Equipment Needed .....	34
Use of Anthracite Coal or Coke .....	34
Firing with Bituminous Coal .....	34
Removal of Ashes .....	36
Firing with Wood .....	37
Stokers, Gas and Oil Burners .....	38
Automatic Controls .....	38
Advantages .....	38
Thermostats .....	38
Application to Warm Air Systems .....	40
Hot Water and Steam Boilers .....	41
Continuous Air Circulation .....	41
Balanced Dampers .....	42
Cleaning and Repairs .....	42
Smokepipe and Chimney .....	42
Warm Air Systems .....	42
Steam and Hot Water Systems .....	44
Saving Fuel .....	44
What Should Be Done to the House .....	44
What Should Be Done to the Heating Plant .....	45
What the Occupants of the House Should Do .....	46
Suggested Reading .....	47

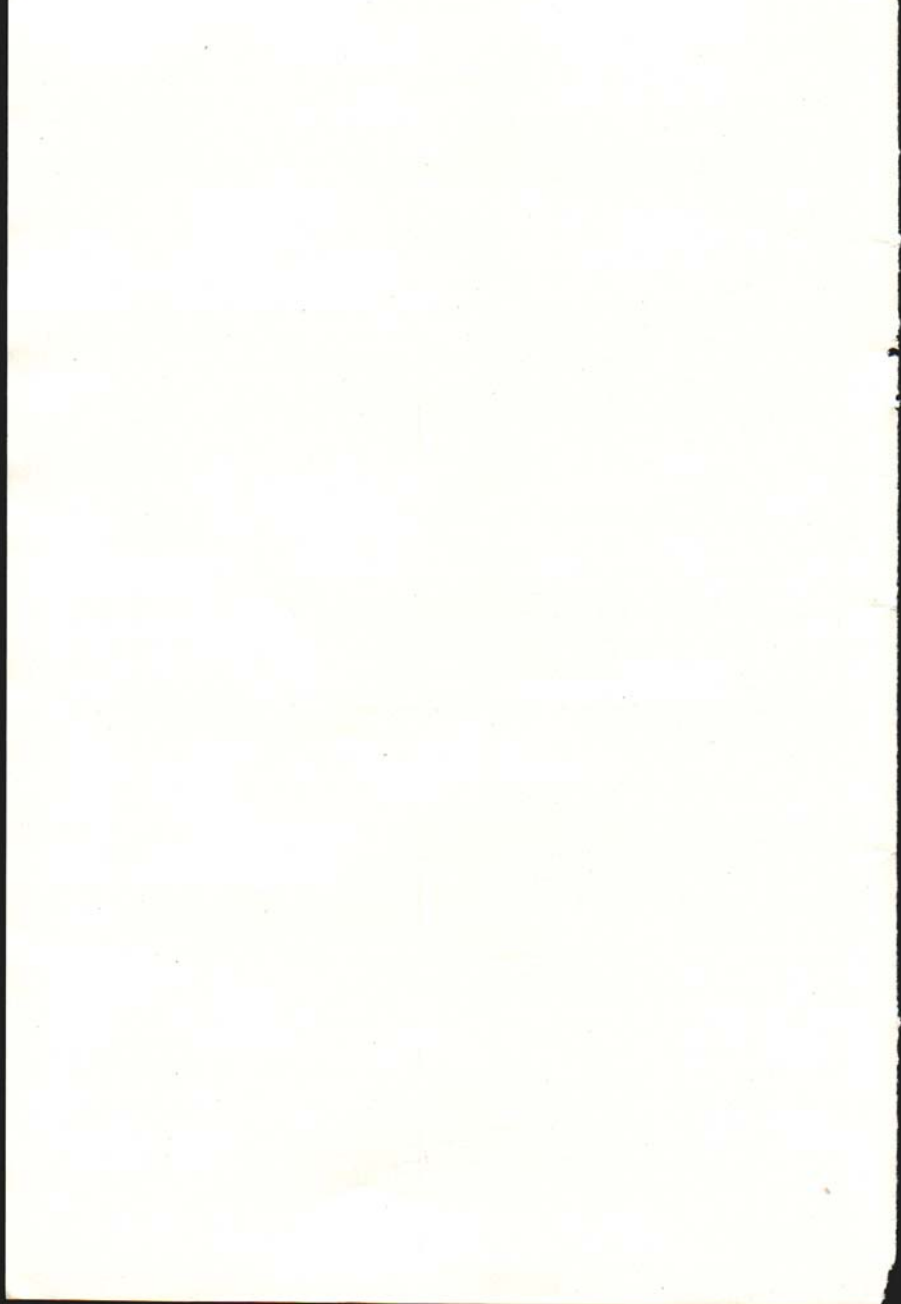

# Greater Economy and Comfort in Heating Michigan Homes

By *JESSE M. CAMPBELL, D. J. RENWICK, R. J. WAALKES*  
and *J. T. ANDERSON*<sup>1</sup>

About 7,500,000 tons of coal alone are consumed annually by the domestic heating plants of Michigan. It is possible for this heating job to be done with less fuel. Users might enjoy a more comfortable house, and, in some cases, have to make fewer trips to the basement if they would, insofar as possible, do the following:

1. Study their heating requirements;
2. Stop avoidable heat losses from the house;
3. Recall principles of combustion and apply proper methods when firing the furnace, and
4. Finally, have the heating equipment cleaned at least once a year. It should be studied for needed repairs and improvements at this time. Many persons do not have the information which the carrying out of such a program requires. The purpose of this bulletin, therefore, is to give the Michigan householder some information on residence heating in a nontechnical form.

## HEAT AND THE HUMAN BODY

Heat is a form of energy which is transferred or actually travels by three methods:

1. *CONDUCTION*. Example: The handle of a frying pan becomes too hot to hold directly in the hand although it is not touched by the fire. Heat is conducted through the metal.
2. *CONVECTION*. Example: An automobile heater heats air, which in turn passes over the passengers warming them. Heat from the heater reaches the passengers by convection.
3. *RADIATION*. Example: The heat we get from the sun is radiated to the earth. Heat travels from hot or warm bodies directly through space to bodies of lower temperature.

<sup>1</sup>All members of the faculty, School of Engineering, Department of Mechanical Engineering, Michigan State College.

The human body is a heating plant, continuously generating heat by oxidation of the foods taken into the stomach. The normal temperature in the deeper parts of the body is 98.6° F. The body's surface or the skin temperature is lower, usually about 80° F. Some persons by nature generate and have to give off more heat than others. A human being is most comfortable when the atmospheric conditions around him are such that heat is leaving his body at the same rate it is being generated. A temperature of 70° F. is comfortable to most persons indoors during the winter months, though there are three other influences which may cause the individual to feel too warm or too cold when the temperature in the house is 70°F.

First, let us suppose the atmosphere in the house is very dry. This causes moisture or perspiration to be evaporated at a faster rate than when the atmospheric moisture is present in greater quantities. Since a relatively great amount of heat is required to evaporate the moisture, and since this heat must be supplied by the skin surface which the moisture is on, a considerable portion of the body heat may be removed in this way. The person may feel cold.

Again, one may sit near a cold wall or a large cold window with an undrawn shade. Some of the body heat will be radiated directly to that cold surface and a chilly sensation will be experienced.

Lastly, a rapid movement of air in the room causes heat to be removed from the body faster by convection and the sensation, again, is that of being too cold.

Raising the house temperature higher than 70° F. might permit a feeling of comfort when any or all of the foregoing methods for the body's heat disposal are present to some extent.

## HEATING PLANTS USED IN MICHIGAN

### GRAVITY WARM AIR SYSTEMS

The most widely used heating plant in Michigan employs air as the heat carrier from the hot walls of the furnace to the various parts of the house. Figure 1 shows a warm air heating plant using coal as a fuel and arranged for hand firing. As the fuel burns, the heat liberated is transferred to the air circulating upward in the jacket around the furnace walls. As the air is heated it rises of its own accord through the leader pipes to the registers in the rooms of the house. Dampers shown in the leader pipes control the quantity of heated air going to each room. Cold air from upstairs may come down the stairway to the return air

register in the floor at the foot of the stairs, as shown, or it may be returned through individual conductors from each upstairs room. Cold air near the floor downstairs also may be returned to the furnace through the single register at the foot of the stairs or through individual pipes.

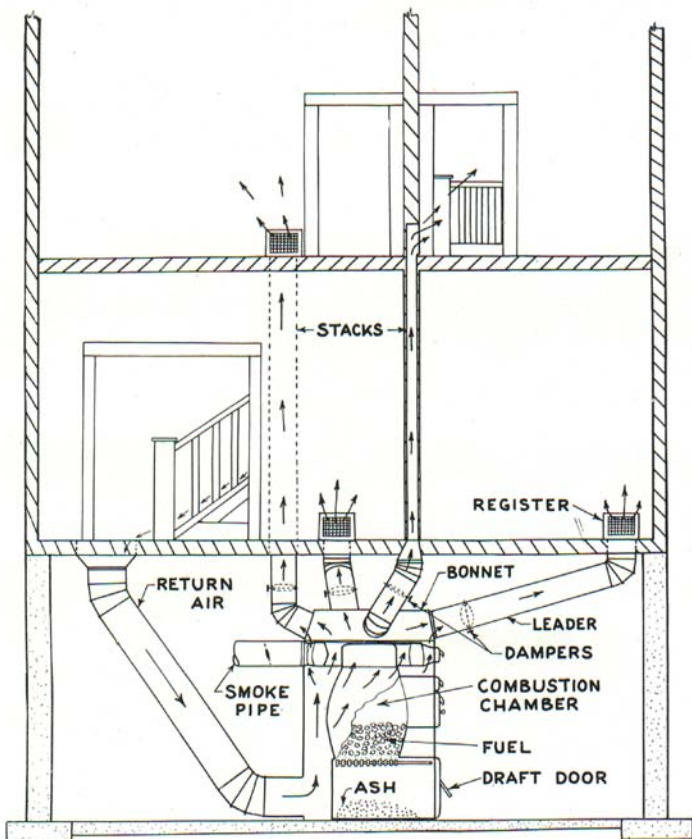

Fig. 1. Warm air furnace.

## PIPELESS AND FLOOR FURNACES

Another form of warm air heating plant is shown in Fig. 2. This type, having no individual piping to conduct the warm air throughout the house, is known as the pipeless furnace. It is most satisfactory in compactly built houses where all of the space to be heated is interconnected by large doorways which may be continuously kept open.

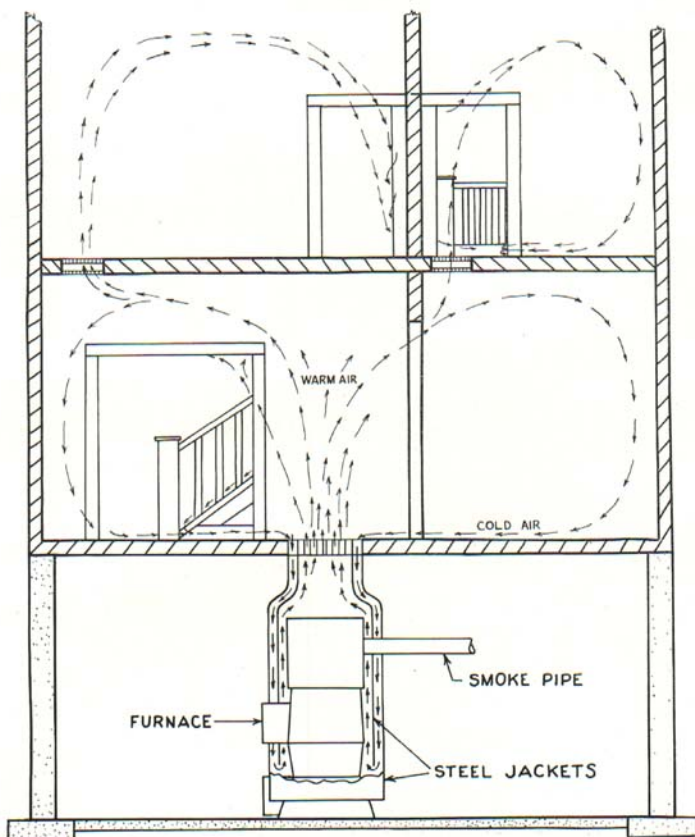

Fig. 2. Pipeless Furnace.



Cold air collecting near the floor finds its way back to the return register which surrounds the warm air register just above the furnace.

Floor furnaces which are small enough to be suspended from the ceiling in the basement also use this principle of circulation.

#### FORCED WARM AIR SYSTEMS

Many of the modern warm air furnaces, in their circulation of the heated air, do not depend on the fact that warm air will rise. A blower draws the return air through a filtering unit which removes dust particles. The air is then forced through the jacket surrounding the hot walls of the furnace and finally expelled in the various rooms of the house through registers which efficiently mix it with the rest of the air in the room. Such a system of heating is known as a forced warm air heating plant. Since the air is circulated by a blower, the furnace and its piping occupy much less space than the so-called gravity warm air system shown in Fig. 1.

#### HOT WATER HEATING PLANTS

Hot water heating plants consist of a fuel burning boiler which is connected by a system of pipes to radiators in the individual rooms of the house. Fig. 3 illustrates such a system. The boiler, piping, and radiators are filled with water. As the water is heated in the boiler it rises, passing through the radiators where it gives up heat and then returns to the boiler. Heat is given off by the radiators to the air circulating around them from the floor toward the ceiling by convection. Furthermore, since the radiator is usually warmer than other objects in the room, some of the heat it gives off is by radiation. Water expands some when heated. This makes the expansion tank a necessity because otherwise the pressure would rise within the system, possibly damaging the radiators or the boiler. The radiators are provided with an air valve which is so constructed inside that air in the radiator is permitted to escape while water is not.

#### STEAM HEATING PLANTS

Another type of heating plant used in some homes employs steam as the carrier of the heat from the fire to the space to be heated. In these plants water partially fills the boiler. Heat from the burning fuel heats the water until steam is formed. The steam flows in pipes to radiators which are located throughout the house. The steam condenses—that is, gives up heat—and becomes water again in the radia-

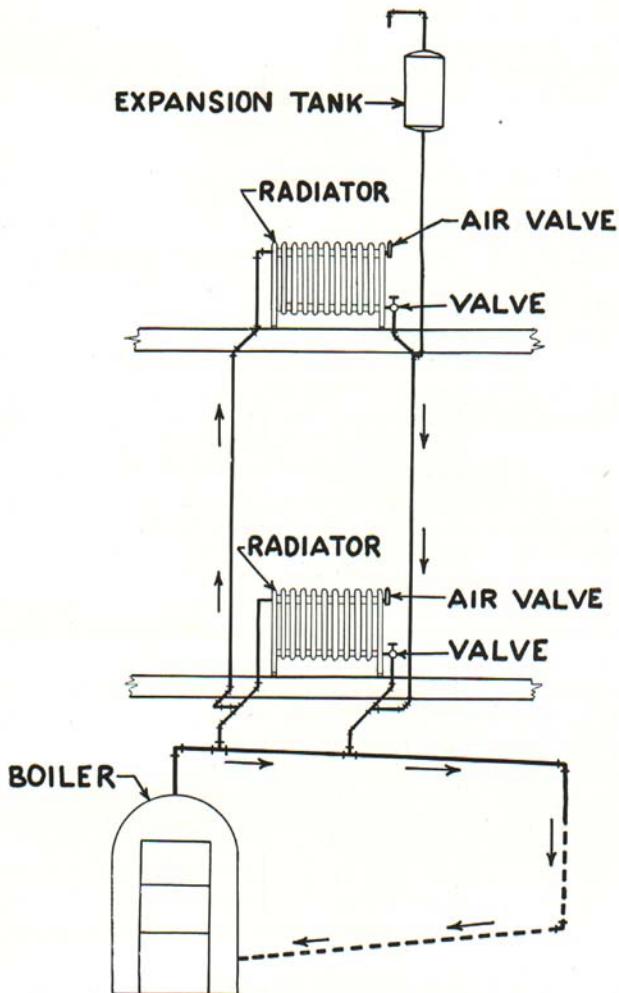

Fig. 3. Hot water furnace.

tors. If the water drains back to the boiler through the single pipe which delivers the steam to the radiator, it is known as the one-pipe steam-heating system.

Other steam-heating systems have a pipe delivering steam to the radiators and a second pipe through which the water returns to the boiler. Although these systems exceed the one-pipe system in original cost they may provide a more even temperature in the house. Such systems are known as the two-pipe steam and vapor system.

### HEATING STOVES

Where homes having no basement use a heating stove without an air jacket around its hot surfaces, a large amount of the heat will be given off as radiant heat. The space immediately around the stove may be comfortable while other parts of the house are cold. If the heater is jacketed so that cold air will be drawn from near the floor into the space between the jacket and the hot walls of the heater and will flow upward and out of the jacketed space around the top of the heater, a circulation of the heated air will be set up all through the house very similar to that provided by the pipeless furnace shown in Fig. 2.

### RADIANT PANEL HEATING

Radiant panel heating, although not a new system of heating<sup>2</sup>, has only recently been used to any appreciable extent in this country. Inasmuch as this method of heating is becoming increasingly popular, some discussion of its characteristics will be in order.

Practically everyone is familiar with the conventional, radiator-type heating, in which a relatively small heating surface at high temperature, 180° to 215° F., is used as a heat source. The radiant panel heating system might be considered as a modification of the radiator system, with the major difference being the use of large flat surfaces at relatively low temperatures, below 150° F., to transmit the same amount of heat.

There are various ways in which the problem of heating these large flat surfaces has been accomplished, using the four common energy sources, steam, hot water, warm air, and electricity.

The steam or hot water installation often employs a concrete floor slab with piping or tubing imbedded in the concrete. This method may also use piping or tubing in the walls or ceiling with metal lath and plaster attached directly to them.

<sup>2</sup>The Romans used one form of radiant panel heating (flue gas circulating in ducts under the floor and in the walls) over 2,000 years ago.

The warm air system consists of warm air circulated through either a chamber formed by suspending a false ceiling from the true ceiling, or through channels under the floor or lined joist or studding spaces. It might be noted that this system can be either open or closed, that is a portion of the air circulated through the panel may be admitted to the living spaces to form the open system, whereas in the closed system no warm air is discharged into the room.

The electrical resistance system is economically feasible for general heating only in areas of low power rates or light heating loads. It may also be practical in special applications in small spot panels for local heating.

It should be kept in mind that heat is transferred from the panel to the room by two means, namely, radiation and convection. Radiation is desired because it will strike all objects in the room and heat them uniformly, doing away with the disadvantage of stratification, the forming of layers of cold air on the floor and hot air at the ceiling. The percentage of the total heat transferred by radiation from a ceiling panel is greater than the percentage radiation from a wall panel, and a wall panel in turn has a greater percentage radiation transfer than a floor panel.

One of the most apparent advantages of radiant panel heating is the absence of visible heating equipment in the room. There are no radiators, convectors, cold air grills or warm air outlets to interfere with the furniture arrangements or decorative scheme. In addition, the presence of uncomfortable hot or cold areas in a room are largely reduced, owing to the radiation type of heating over a large area. It follows then that the usual complaints about cold outside walls and cold floors are eliminated for the same reason, regardless of whether floor, wall, or ceiling panels are used. Wall and floor surface temperatures in radiant panel heating will tend to be higher without the accompanying high air temperatures necessary with other heating systems. The high air temperatures produce the uncomfortable sensation of stuffiness.

The claims sometimes made, however, that radiant heating will allow the home owner to be comfortable in a room at 60° F. air temperature are only possible under carefully controlled conditions and at considerable expense. In the average installation without appreciable ventilation the room air will be warmed by convection from the radiant panels and will end up in the 70° F. region characteristic of any heating system. It may be seen that if enough fresh cool air were

continuously admitted to the room that the occupants could be kept comfortable by radiation from the panel and still have the surrounding air at 60° F. This is far from economical at the present time, both from the standpoint of cost of equipment and cost of fuel necessary. The advantage of high relative humidity due to lower air temperatures claimed for radiant panel heating therefore hinges upon this claim. True enough, for a given weight of moisture in the air the relative humidity will go up with a decrease in air temperature and, consequently, with increased relative humidity the drying effects upon the respiratory system and furniture will be reduced.

The disadvantages of radiant panel heating include the obvious lack of ventilation. Ventilation in the true sense that fresh outdoor air is introduced to the residential dwelling is practically nonexistent in any heating system, but the circulation of air in a warm air heating system does play a part in dissipating or diluting odors and smoke that the closed radiant panel system cannot. Naturally, in the open-cycle radiant panel system this can be effected as can the accompanying advantages of air filtering and humidification. Another disadvantage common to radiant panel heating is its overriding or flywheel effect. This is the heating lag caused by the necessity of having to warm up heavy concrete slabs or heavy wall sections when the system starts up and the subsequent giving up of heat to the room when the demand for heat is over, causing, quite often, an uncomfortably warm atmosphere. This disadvantage may be minimized by using light panel sections constructed of materials having a low specific heat or thermal capacity.

In considering the use of radiant panel heating, the limitation of maximum output should be looked into. For example, there are a limited number of square feet in any given floor, and the maximum temperature usually accepted as being comfortable for this floor is 85° F. Temperatures higher than this will cause complaints from people with sensitive feet. If it is necessary to go to yet higher temperatures to supply the heat loss of the room, a ceiling panel may be used. The maximum temperature acceptable in a ceiling panel is 130° F., above which the plaster will deteriorate at too rapid a rate.

As with any heating system, radiant panel heating will operate most satisfactorily when sufficient insulation is provided on cold walls and ceilings. Of particular notice in the concrete floor slab installation is the edge insulation. In a floor slab without edge insulation the edges of the slab, or in other words, the portion of the floor near the

outside walls, will be definitely chilled due to excessive heat loss from that edge. To remedy this, one should specify that the edge of the slab be provided with a layer of suitable insulation. In addition, for economical heating the fill below the slab should be as dry as possible. The presence of moisture will cause larger heat losses to the ground. One way to prevent this effect is to use a gravel bed below the slab provided with tile to insure good drainage. In extremely wet or marshy soil it sometimes is deemed advisable to construct a waterproof box to put the gravel in as a base for the slab.

### THE HEAT PUMP

Year-around comfort conditioning of homes and buildings by means of the system called the "heat pump" or also "reverse cycle refrigeration" is not new; Lord Kelvin is credited with being the originator of the idea about 100 years ago. But until recently little attempt has been done to develop the system into a practical and economical method of year-around air conditioning. Only during the last 15 years has there been a gradually increasing interest shown in the system, with the electric generation utilities and the manufacturers of air conditioning equipment leading the study and development of the system to the point where it is now considered quite practical. Economically at present it could be regarded as somewhat on the luxury side for the average person to possess; but mass production methods which are now in progress are expected to bring the first cost within the reach of more and more people. Even now one may install a heat pump system for about the same total cost as it would cost to put in a good mechanically operated heating system plus a separate mechanically refrigerated air conditioning unit. And where somewhat lower electrical rates prevail (most heat pump systems are electrically operated at present) the operating cost compares favorably with the more expensive heating fuels (as oil or gas) in various localities. Further research on the efficiency of the system and also possible readjustment of electrical rates if the heat pump increases sufficiently in popularity are both expected to improve the operating cost.

#### How It Works

Very briefly, the heat pump operates similar to any refrigerator system. Like the kitchen refrigerator, it has a set of coils which are kept colder than the surrounding air by refrigerant inside the coils.

However, this cold coil is placed outside the home and the refrigerant, which is thus continually receiving heat from the outdoor air, is pumped to a second set of coils called a condenser, located within the home. The compressor raises the temperature of the refrigerant and forces it into the condenser warm enough to effectively heat the home. This part of the system thus takes the place of the conventional heating furnace. Finally, after giving up its heat within the home, the refrigerant returns to the coil outdoors to get another load of heat. This circulation of refrigerant is maintained by the compressor which is usually driven by an electric motor as long as heat is required in the home.

The ratios of heat involved are approximately as follows: Two (or three) units of heat received from outdoors free at the expense of one electrical equivalent heat unit at the motor and the total of three (or four) units of heat delivered by the condenser to heat the home; or approximately three units of heat to the home at the expense of one unit of electrical energy is typical operation. This ratio of 3 to 1 is known as "the coefficient of performance" or simply "COP" (as used in Table 3) and is an important measure of the efficiency and cost of operating the system. This COP is affected mostly by weather conditions, for as the weather gets colder outside, the COP is lowered and conversely. Consequently, the system is more costly to operate in severe weather for two reasons, namely 1) it must supply more heat to the home, and 2) it operates less efficiently.

Instead of using outdoor air as the original source of heat, some heat pump systems have been built with coils buried in the ground in which case the ground then becomes the heat source, and still other systems are using lake or well water as the primary heat source. The main advantage of any of these latter systems is that the COP (or efficiency) is considerably improved. Also, by a simple switching arrangement, making use of valves, any of these systems can easily be converted into an air conditioner for summer operation and cool the home comfortably while rejecting the surplus heat to the outdoors.

### Advantages and Disadvantages of the System

Following is a brief summary of several factors to consider in comparing the heat pump system with conventional air conditioning systems as well as some of the special problems and characteristics of the system:

1. The system is clean, compact, no coal bin or tanks to occupy usable basement space, no chimney, no fuel delivery worries or ash removal problem; it can be made completely automatic and provides year-around comfort conditioning of the home. However, there are more moving parts than most conventional home heating systems have, and that suggests a possible increase of service or maintenance calls, although refrigeration appliances are becoming continually more reliable in this respect.

2. The capacity of the heat pump is just the reverse of what one would desire in that as the weather becomes more severe, the inherent capacity of the system decreases as well as its efficiency; so it requires very careful engineering to design and install a system for the correct capacity for the most severe weather and yet have a well balanced and reasonably efficient system for year-round operation. Small errors in figuring or installing most of the conventional types of heating systems are not nearly so serious. It is expected that further research of capacity control methods, say by variable speed compressor drives, will help to do away with or modify this inherently detrimental characteristic of the heat pump.

3. Heat pump installations for certain commercial and industrial uses are being tried and are proving more economical in many cases than residential installations (in proportion of size), owing to better year-around load characteristics, which result in better balance between winter and summer heat loads. Consequently, more of the research and development work is now being done in commercial installations than residential. Thus, individual home owners are relieved of the costly expense of experimentation and will still be able to profit from the results of these commercial studies as new discoveries and proper techniques evolve.

4. Installation techniques for the heat pump components are considerably different from those for conventional systems. For one thing, the amount of air to circulate through the home for heating should be at least twice that used in present practice, owing to the lower temperature of the air supplied to rooms. This results in larger ductwork and registers and somewhat more power for the fan motors. Therefore, one should not expect to be able to change over from a conventional system to the heat pump with a few minor changes, for it would require a complete revamping of the air circulation system.



5. The heat pump offers a number of problems of an electrical nature and, hence, the great interest of public utility companies in promoting research in the system. For instance, the total annual usage of electricity per home using a heat pump would be about three or four times that for a home with the present conventional types of heating systems. This apparently large and attractive potential market for the increased sale of electricity is accompanied by several drawbacks from the viewpoint of the utilities. Thus, wide adoption of the heat pump in residential districts would require a gradual enlargement of the electric generation and transmission systems to handle the increased load. The high starting current of several motors starting all at one time would be especially severe after a possible temporary power interruption and would seem to require some form of sequence starting devices to alleviate this condition. Then, the demand character of the load may not be particularly good in certain localities, since (as in Michigan climate) there would be a high rate of current usage during winter months and again in the short summer season, while current requirements would be quite low in both fall and spring.

6. It is possible to conserve our natural fuel resources by use of the heat pump; it is feasible to use only two-thirds of the fuel as by conventional direct-heating or firing methods. No doubt as our natural fuel supplies dwindle further it will be an important motivating reason for increased promotion of the heat pump system for residences. Also future atomic power development could conceivably have great influence on the degree to which the heat pump may be used.

7. In general, at this time, it may be said that for residential purposes the first cost of a heat pump is about equal to that of a conventional mechanical heating system plus the cost of a present-day type of mechanically refrigerated comfort cooling unit. And where low electrical power rates prevail, the annual operating cost is about coincident with the usual fuel cost for conventional heating systems.

#### DISTRIBUTION

The distribution of the more common types of heating plants in Michigan in 1940 is shown in Table 1.

TABLE 1—Distribution of heating plants in Michigan\*

Type of heating plant	Number	Percent of total
Steam or hot water.....	270,603	19.6
Piped warm air.....	552,025	40.0
Pipeless warm air.....	36,631	2.7
Heating stove.....	507,568	36.7
Other or none.....	13,956	1.0
Total.....	1,380,783	100.0

\*United States Department of Commerce, Bureau of Census, *Sixteenth Census of the United States*, 1940.

#### ADVANTAGES AND DISADVANTAGES OF THE MORE COMMON SYSTEMS

##### GRAVITY WARM AIR SYSTEM

###### *Advantages:*

1. Quick in response to heating demands
2. Low in first cost
3. Gives long period of service with little maintenance cost

###### *Disadvantages:*

1. Furnace must be centrally located in basement, and, with air pipes, takes up much room
2. May not satisfactorily heat rooms on the windward side of the house
3. No means of filtering circulated air
4. May not provide even house temperatures

##### PIPELESS AND FLOOR FURNACE

###### *Advantages:*

1. Lowest initial cost
2. May require little room in the basement

###### *Disadvantages:*

1. Must be used in small houses where the heated space is interconnected by large doors which should be left open.
2. Generally does not provide sufficient heat in bathrooms
3. May produce cold drafts near the floors

## FORCED WARM AIR SYSTEM

*Advantages:*

1. Quickest in response to heating demands and offers a good means of controlling heat in all rooms of the house
2. Circulated air may be filtered
3. Well adapted to humidity control
4. May use small warm and return air registers located in the walls instead of the floor
5. Takes up little space in the basement

*Disadvantages:*

1. Operation of fan adds somewhat to operating costs. Also, if fan is not properly installed it may produce noises
2. Higher first cost than for other warm air systems.

## HOT WATER HEATING PLANT

*Advantages:*

1. Usually provides a rather even temperature in the house
2. A system well adapted to the use of farmers who may wish to hand-fire the boiler with wood. Heat stored in the water prevents a rapid drop in the house temperature during periods when the fire is low
3. System requires a relatively small space in the basement

*Disadvantages:*

1. High first cost
2. Radiators, if not set in the wall, may interfere with placement of furniture and cleaning in the house
3. Slow in response to a change in the heating requirements of the house
4. Subject to freezing if furnace fire dies out
5. Less adapted to use of low-grade coals

### ONE-PIPE STEAM HEATING PLANT

*Advantages:*

1. Relatively low first cost
2. System is small, requiring little room in the basement

*Disadvantages:*

1. May not provide even temperatures in the house, especially where boiler is hand fired
2. Radiators, if not set in the wall, may be in the way of furniture and interfere with cleaning
3. If not installed by a reputable heating contractor, the system may be noisy and fail to heat certain rooms of the house
4. Subject to freezing if furnace fire is left unattended over long periods

### TWO-PIPE STEAM HEATING PLANT

*Advantages:*

1. This system, and especially the vapor system, may provide very even temperatures throughout the house
2. Adapted to large buildings

*Disadvantages:*

1. Rather high first cost
2. Subject to freezing when furnace fire is left unattended over long periods
3. Radiators, when not set in the wall may interfere with placement of furniture and cleaning

### HUMIDITY

The term relative humidity is used to specify the extent to which moisture is present in the atmosphere. A relative humidity of 100 percent means that a completely saturated condition has been reached. Lower percentages mean less moisture. A relative humidity of 5 percent would mean a very dry atmosphere.

### WHAT HUMIDITY IS BEST?

Effect of the humidity on health is not very well understood. Very low relative humidities, less than 15 percent, are likely to damage certain articles in the house. Such humidities may be found uncomfortable and should, insofar as possible, be avoided. Humidities of 40 to 60 percent are enjoyed by most people. To keep the heated space moistened to this extent during the winter requires special humidifying equipment. Furthermore, frosting of the windows will be found objectionable and condensation of moisture in the walls or in the attic may occur.

### CONDENSATION IN WALLS

In houses where humidifying equipment is used which will keep the relative humidity at 40 percent or higher, or where there is much cooking or a considerable use of hot water for baths, moisture will travel through the plaster into the walls in such quantities that some of it may be condensed in the wall structure instead of passing on through to the outside. Freezing of this moisture in the wall may cause lifting and peeling of the paint on the house. In the spring the accumulated frost thaws and may damage the materials in the wall considerably before the moisture is evaporated.

The surest way to avoid trouble with condensation in houses not equipped with vapor barriers is to provide humidities which probably should not exceed 30 percent during the coldest weather.

The attic space above insulated ceilings should be ventilated.

Excessive moisture which occasionally comes from cooking, drying washed clothes or prolonged use of hot water in the bathroom may be disposed of by providing more ventilation in the affected locality for a short time.

In the new house construction asphalt paper, sheets of metal foil or some other material known as a *vapor barrier* may be put on the warm side of the insulation in the walls and ceiling as shown in Fig. 4. This should not be omitted when building a new house if the higher humidities are wanted during the winter months.

There is no satisfactory means of installing vapor barriers in walls or ceilings after the plaster has been applied. Interior paints, especially those having a high gloss, have been found helpful. Reputable dealers in paints and wall coverings may be able to suggest materials

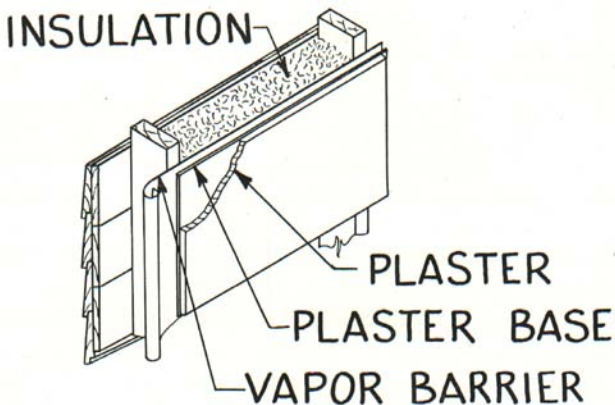

Fig. 4. Location of vapor barrier in a wall.

and a method of application on interior wall surfaces which will resist the passage of moisture into the plaster and from there into colder parts of the wall where it may condense.

#### HUMIDIFYING METHODS

The evaporating pan in the warm air furnace should be scraped out clean and regularly filled with water. More evaporation may be had from pans located in the bonnet than those whose opening is just below the firing door. Pans in either location are not likely to evaporate as much water as needed, but are a help.

Those having hot water or steam heating plants may place evaporating pans on the radiators.

During the coldest weather, water evaporated from a vessel on the kitchen stove is helpful.

Some warm air furnaces are provided with a means of spraying water into the circulated air until the humidity in the house comes up to the setting on the instrument, controlling the flow of the spray water. These furnaces or air-conditioning units will provide almost any humidity desired.

## INSULATION

### REQUIREMENTS

Insulating materials should be good heat insulators and should be fireproof or at least fire resistant. The material should repel vermin and be in a form readily applied to the walls and ceilings of a house.

### TYPES OF INSULATION

**FILL INSULATION** is sold as loose material in the form of grains, pellets or fiber-like particles. This form may be poured over ceilings, in unfloored attics and leveled with a board or a garden rake. Also, it may be blown into wall cavities or into ceilings having floored attics.

**RIGID INSULATION** is usually sold as large structurally strong boards measuring 4 by 8 feet. It is made from wood, sugar cane or other vegetable fibers and may be applied as a sheathing under shingles or other exterior wall structures or may be applied underneath the plaster on the interior side of the wall. This insulation is most readily used in new house construction, but may be employed when finishing off attics or recreation rooms in older houses.

**FLEXIBLE OR BLANKET INSULATION** may consist of felted hair or may be any of the fill insulating materials placed between two pieces of water resistant paper and stitched or otherwise fastened so that it will not slip out of place. The blanket is sold in a roll, having the proper width and with a paper covering folded and flattened along its edges so that it may be nailed or tacked into place between the wall studs, ceiling joists, or rafters underneath the roof. This insulation cannot be applied to the finished sidewalls of a house but may be used as a ceiling insulation for unfloored attics or may be used in finishing off rooms in the attic. The paper covering on blanket insulation may act as a vapor barrier.

**INSULATING BATTS** are similar to fill insulations except that the material comes cut into rectangular sections which fit snugly between wall studding, ceiling joists or rafters spaced at standard dimensions. The batts may be encased in moisture-resistant paper as the blanket insulation.

**METALLIC INSULATIONS** are also excellent vapor barriers and are placed in the walls or elsewhere so that either one or both sides of the thin metal sheet will face an air space.

### GENERAL BENEFITS OF INSULATION

In addition to being a barrier to the flow of heat from the house and saving fuel, insulation is just as effective in keeping heat out of the house during the summer. Insulated houses will have a wall temperature more nearly equal to that of the air in the house. Street noises are not so readily heard through the insulated walls. Both features promote a feeling of comfort and security for the occupants of the house. Well insulated walls and ceilings do not catch and hold dust particles as readily as those not insulated.

Walls and ceilings are more fire resistant when filled with an insulating material which will not burn.

### COSTS AND SAVINGS

The cost of insulation alone is usually directly proportional to the thickness.

The savings effected in fuel, however, are not in that ratio. The first inch of thickness gives the greatest saving in terms of money invested in insulation. The next inch saves less fuel than the first and the third inch of thickness saves less than the second inch. In fact, the thickness might be made 20 inches or even 100 inches, and the passage of heat through such an insulated wall would not be stopped entirely.

Fills in attics are usually less expensive and, as a rule, show a greater saving per 100 square feet of insulated area than would be obtained if the insulation were used in the walls.

Savings, expressed as pounds of coal per heating season for 100 square feet of wall area and for 100 square feet of ceiling area are shown in Table 2.

### WEATHERSTRIPPING FOR WINDOWS AND DOORS

Figure 5 shows how air leakage takes place through the cracks around the average windows in a house. Cold air is seen to be passing into the house around the window exposed to the cold wind. This cold air reduces comfort immediately around the window and, thus, reduces the livable space in the house. Furthermore, the cold air brings in dirt, increasing the house cleaning requirements. The warm air which is seen to be leaving through the window cracks on the opposite side of the house represents an avoidable loss of heat.



TABLE 2—Fuel saved by various means

Item	Probable pounds of coal saved during one heating season when used in				
	Detroit	Escanaba	Houghton	Lansing	Traverse City
WALLS: 100 square feet. 1 inch of rigid insulation in outside wall . . . . .	160	212	217	172	183
3 $\frac{5}{8}$ inches of fill insulation in outside wall . . . . .	285	380	388	308	328
CEILINGS: 100 square feet. 1 inch blanket used as a ceiling insulation. No attic floor air space between ceiling and blanket . . . . .	260	347	354	281	290
2 inches of fill insulation between ceiling joists. No attic floor . . . . .	313	416	426	338	360
3 $\frac{5}{8}$ inches of fill insulation between ceiling joists. No attic floor . . . . .	362	485	495	392	416
6 inches of fill insulation blown between ceiling joists. Attic floored . . . . .	415	551	563	447	475
WINDOWS: Weather strip only for 100 square feet of average windows or doors . . . . .	520	691	706	560	595
Storm sash only for 100 square feet of average windows (closely fitted) . . . . .	1,480	1,980	2,020	1,600	1,700
Both weatherstrip and storm sash for 100 square feet of average windows or doors . . . . .	1,800	2,400	2,450	1,945	2,070

Weatherstripping of the windows eliminates most of the foregoing troubles. It will not, however, lower the temperature of the window glass and prevent heat losses and discomfort in the house on that account.

Savings in fuel due to weatherstripping are shown in Table 2. Outside doors act the same as windows with regard to air leakage. Rain does not blow in underneath a well weather-stripped door.

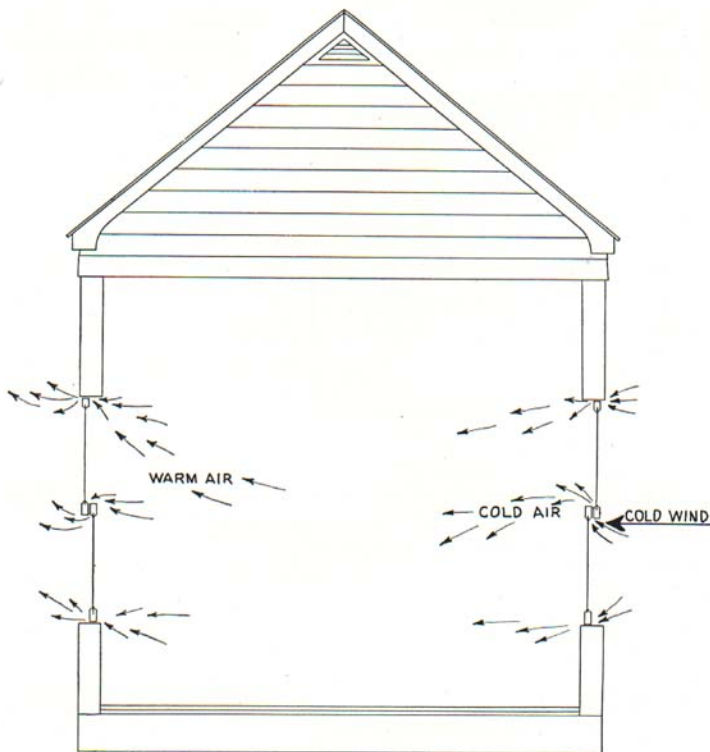

Fig. 5. Air leakage through windows.

#### TREATMENT FOR BEDROOMS

Sleeping with raised windows makes the bedroom door become an outside door with regard to heat losses. The bedroom door should be closed. Even then, in most cases, cold air leaks through the crack underneath the door to the main part of the house.

A device known as an automatic door bottom will eliminate air leaking underneath a door, and when applied to a door a felt pad of the door's width presses snugly against the floor, completely sealing the crack while the door remains closed. The automatic door bottom

operates mechanically when the door is opened, actually lifting up the felt pad and permitting it to pass over rugs or carpeting. These devices should save fuel and may be obtained through contractors who do weatherstripping.

#### CAULKING AROUND WINDOW FRAMES

Weatherstripping will not stop air leakage around the outside edges of a window frame. Window frames which are set in masonry walls such as brick, stone, or cinderblocks are subject to loosening by unequal expansion and contraction. The cracks formed should be filled with an elastic and non-hardening putty, sometimes called *caulking compound*. This material is sold by dealers in building supplies. It is most readily applied with a hand gun. Though, in the case of small jobs, it may be forced into the crack with a putty knife.

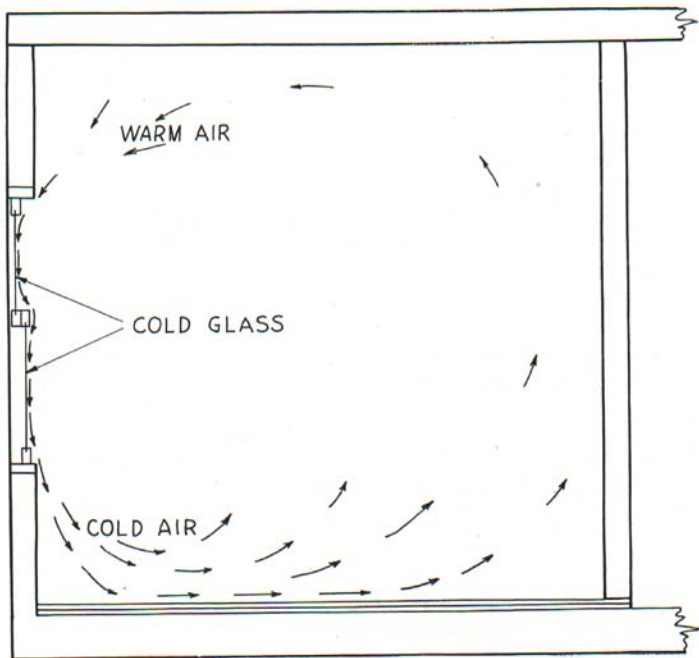

Fig. 6. Drafts caused by cold window glass.

## STORM WINDOWS AND STORM DOORS

Cold window glass will cause drafts to be set up in a house as shown in Fig. 6. This cold glass causes discomfort for another reason, namely, heat is radiated from the human body to this cold surface.

Application of storm windows provides two thicknesses of glass which are separated by an air space. Heat does not travel through this combination as readily as through a single piece of glass. The inside thickness of glass is kept at a higher temperature. The result is more comfort near the window and a saving in fuel. Furthermore, if storm windows are provided for windows which are not weather-stripped, an additional saving in fuel and added comfort in the house is obtained, due to the storm window's stopping some of the air leakage.

The best possible treatment for windows is a good weatherstripping job in addition to storm windows which are not too closely fitted. At the time of installation considerable additional labor is required to obtain a real tight-fitting storm sash. Tight fitting followed by some swelling of the wood may cause the sash to be damaged when removed for cleaning. Very close fitting favors condensation of moisture on the inner glass surfaces. To prevent the condensation, auger holes are sometimes bored through the sash. Granting the tight sash will save more heat, a consideration of the factors just enumerated would seem to make extra close fitting inadvisable.

Savings for storm windows both with and without weatherstripping are shown in Table 2.

Storm doors operate the same as storm windows with regard to fuel saving except that they may play an even more important role in stopping air leakage.

## FUELS

The 1940 Census of the United States<sup>3</sup> shows that approximately 79 percent of Michigan's homes are heated with coal or coke, about 10 percent use wood, 6.5 percent fuel oil, and nearly 4 percent burn gas.

### AVAILABILITY OF FUELS

It appears that we have sufficient coal to last, at our present rate of consumption, for several thousand years. It is taken for granted

<sup>3</sup>United States Department of Commerce, Bureau of Census, *Sixteenth Census of the United States, 1940.*

that coke and manufactured gas will continue to be made from coal. It may develop that the demand for such premium fuels will decrease, however, as more efficient and generally desirable equipment is developed to burn bituminous coals.

At the present rate of consumption our known petroleum reserve is expected to last about 15 or 20 years and our natural gas reserve about 30 years.<sup>4</sup>

Wood fuel is now less plentiful—in fact, there was a time when dry and seasoned wood split from the body of medium-sized oak trees was often demanded by the users of wood fuels. It was known that this type of wood fuel produced a hot and lasting fire, contained a minimum of the tree's bark and might, therefore, produce less ashes. Oak and other hardwood trees from which wood may be split with a minimum amount of labor have long been so much in demand for lumber that farmers have found it more profitable to sell the trees and purchase coal. Thus, wood fuels which are mostly in use today are either a byproduct of the lumbering industry or are produced from dead or scrubby trees with little thought given to the woods' fuel qualities.

Since it is expected that wood fuel of this type will be produced in some quantity for a long time to come, and thrifty people will wish to utilize it, furnaces which will offer more convenience and economy will undoubtedly be developed and made available for its use.

#### COALS

The coals used for domestic heating are usually as follows:

1. *ANTHRACITE* is a very hard coal composed almost entirely of carbon as the combustible substance and containing a minimum of volatile<sup>5</sup> combustible materials which are driven off by heat in the furnace to either burn as a gas or possibly appear as smoke. This coal is much sought after for its clean burning properties and the relatively high furnace efficiencies it permits.
2. *BITUMINOUS*, also known as soft coal, contains more volatile combustible elements and may produce more smoke than anthracite. Bituminous coals vary over wide limits with respect to the performance they give in a domestic furnace. Some burn more rapidly than others, some produce more smoke and

<sup>4</sup>Ralph A. Sherman, *Fuels of the Future*, Battelle Memorial Institute, Columbus, Ohio.

<sup>5</sup>Volatile materials are those which readily change to gases or vapors when heated.

some are high in ash content. Many bituminous coals have a higher heating value than anthracite. The price charged for a certain bituminous coal is proportional to coal's general desirability as a fuel.

### COKE

Coke is a fuel which is made by removing the volatile substances from a coal. The composition of the finished coke is almost entirely carbon, as a combustible material, along with the ash contained in the original coal.

The principal advantages of coke are its light weight, freedom from smoking, relative cleanliness, and its quick response to a change in the heating requirements.

### OPERATING COST COMPARISONS OF VARIOUS HEATING SYSTEMS

The following table has been prepared to show the comparative annual energy costs of heating a small size six-room home by the various methods listed.

TABLE 3—Annual heating costs for typical 6-room house in Detroit area

Fuel	Heating value	Firing method	Efficiency or COP	Annual amount used	Unit cost	Total annual cost
Bituminous coal	14,500 Btu./lb. ....	Hand. ....	55%	6.25 ton. ....	\$10/ton. ....	\$ 62.50
		Hand. ....	55%	6.25 ton. ....	\$15/ton. ....	94.00
		Stoker. ....	65%	5.4 ton. ....	10/ton. ....	54.00
		Stoker. ....	65%	5.4 ton. ....	15/ton. ....	79.50
No. 2 Fuel oil	135,000 Btu./gal. ....	Automatic. . .	70%	1,060 gal. ....	.10/gal. ....	106.00
		Automatic. . .	70%	1,060 gal. ....	.15/gal. ....	159.00
		Automatic. . .	70%	1,060 gal. ....	.20/gal. ....	212.00
Natural gas	1,000 Btu./cu. ft. . .	Automatic. . .	75%	133,000 cu. ft. . .	.50/m cu. ft.	66.50
		Automatic. . .	80%	125,000 cu. ft. . .	.50/m cu. ft.	62.50
Artificial gas	550 Btu./cu. ft. . .	Automatic. . .	75%	242,000 cu. ft. . .	.70/m cu. ft.	169.00
		Automatic. . .	80%	228,000 cu. ft. . .	.70/m cu. ft.	159.00
Electricity	3,413 Btu./kw. hr.	Direct Res. . .	100%	29,300 kw. hr.	.01/kw. hr.	293.00
		Direct Res. . .	100%	29,300 kw. hr.	.02/kw. hr.	586.00
		Heat Pump. . .	3	9,770 kw. hr.	.01/kw. hr.	*97.70
		Heat Pump. . .	3	9,770 kw. hr.	.02/kw. hr.	*195.40
		Heat Pump. . .	4	7,320 kw. hr.	.01/kw. hr.	*73.20
Heat Pump. . .	4	7,320 kw. hr.	.02/kw. hr.	*146.40		

\*To the annual cost of heating by the heat pump system should be added an estimated 10% to 15% more for summer cooling operation.

TABLE 4—Probable furnace efficiencies

Fuel	Type of furnace	Efficiency Percent
Anthracite coal	Hand fired	60 - 70
Bituminous coal	Hand fired	45 - 55
Bituminous coal	Stoker fired	55 - 65
Wood	Hand fired	40 - 50
Fuel oil	Conversion burner	50 - 70
Fuel oil	Furnace designed for oil	75 - 85
Natural gas	Conversion burner	60 - 70
Natural gas	Furnace designed for gas	75 - 85

The values for the Table 3 are based on the house having an annual heat loss of 100,000,000 Btu, which could be typical of the following: Two story, 24' x 25' house with full basement; well insulated walls and second floor ceiling, storm sash and doors throughout; climate similar to Detroit region.

#### HOW TO PURCHASE COAL

A good coal dealer should be given a description of your heating equipment and your heating requirements. Serious consideration should be given to his recommendations in regard to the particular coal you should buy and how you should use it.

In the purchase of coal, little will be gained by looking for bargains. The best place to save the fuel dollar is at home through the use of better management of the heating plant and the elimination of heat losses from the house.

When a satisfactory coal has been found, have the bin filled during the early summer of each year.

#### HOW COAL BURNS IN A FURNACE

The heating furnace will have an opening in the ashpit door, provided with a shutter, to regulate the air going into the ashpit and up through the grates and the fuel bed as shown in Fig. 7. Air admitted at this point is known as *primary air*. Air is also admitted to the furnace through an opening in the firing door which may be varied usually by means of a sliding shutter. This is called *secondary air*. The rate at which the primary and secondary air will pass into the furnace will also depend on the draft which is controlled by the check damper located in the smoke pipe.

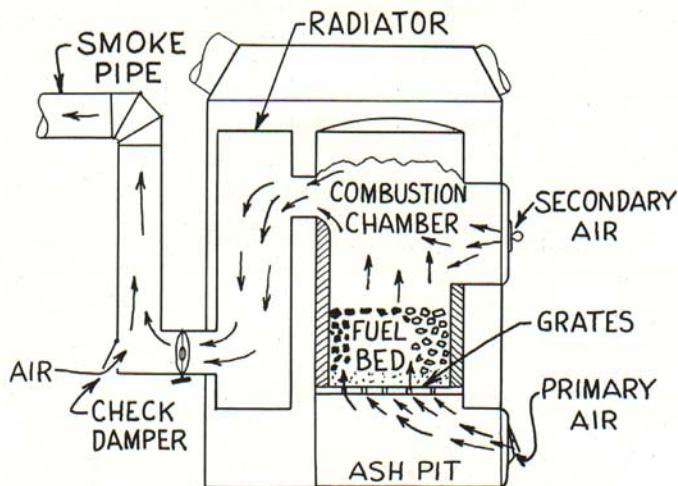

Fig. 7. Distribution of primary and secondary air in a furnace.

Coals are composed of combustible materials which are known as volatile matter and fixed carbon.

**VOLATILE MATTER** consists of the elements which are driven from the coal in the form of combustible gases as the temperature of the coal rises in the furnace. For 100 pounds of bituminous coal burned, there are 30 to 40 pounds of this combustible gas liberated. The heating value of these gases may be equal to more than 30 percent of the heat in the coal. In addition to losing much of the coal's heat, large quantities of smoke may be produced when the gases formed by the volatile matter are not efficiently burned in the combustion space of the furnace.

**FIXED CARBON** is the solid combustible material which remains in the firepot to burn as red coals after the moisture and volatile matter have been driven off.

During the combustion process oxygen must chemically unite with the burnable elements of the coal. For the fuel to be burned rapidly and completely the following requirements must be met in the furnace:



1. There must be sufficient oxygen.
2. There must be efficient mixing of oxygen with the various gases formed from the fuel.
3. The temperature at the point of meeting of the oxygen and fuel must be sufficiently high.

The steps in the burning or combustion of a piece of coal may be described as follows:

First, the moisture is vaporized and passes from the furnace through the smoke pipe. Next, as the coal continues to rise in temperature, it softens and gives off the volatile matter. Finally, the fixed carbon which is left in the firepot burns, leaving the ash as a noncombustible residue. The primary air which passes up through the fuel bed supplies oxygen to burn the fixed carbon. All of the oxygen may not be used and if such is the case, it will be available to burn the volatile matter in the combustion chamber. Secondary air is admitted to supplement the oxygen supply in the combustion chamber.

The temperature in the combustion chamber depends substantially upon the area occupied by live coals at the top of the fuel bed.

It is not usually possible to control the temperature in the combustion chamber and the amount of primary and secondary air with sufficient accuracy to burn all of the volatile matter driven from the coal into the combustion space. Poor mixing of the combustibles with the oxygen of the secondary air and the fact that this air enters the combustion chamber in a cold condition are other factors which are not favorable to high combustion efficiency in the combustion chamber. Combustible gases which fail to burn in the combustion space go out through the smoke pipe as smoke or invisible gases and represent a direct loss of fuel.

Now it must be recalled that air is only about 21 percent oxygen by volume. The 79 percent remaining is principally nitrogen. The nitrogen plays no part in the combustion process, yet must be admitted into the furnace as a part of the air which supplies the essential oxygen. It must be heated to combustion temperatures and then allowed to pass out through the smoke pipe to the chimney. This explains an unavoidable heat loss in the operation of a furnace. The loss is kept at the lowest possible value by admitting only enough primary and secondary air to the furnace to burn the fuel efficiently, and no more.

## FURNACE FIRING

### EQUIPMENT NEEDED

A round steel poker bent or curved so that all of the grate area may be reached or probed with it is required. Other essential items are a good shovel and some suitable containers for ashes. A small hoe for removal of ash and clinker tongs may be found useful.

The coal should be stored in a bin provided with a door which is near the furnace. Walking into the bin to get coal, results in a long carry with the shovel and the spreading of coal dust which sticks to the shoes. This may be remedied by providing the bin with a sloping bottom which will deliver the coal to an opening near the front of the furnace, and from which point all the coal in the bin may finally be reached with the shovel.

### USE OF ANTHRACITE COAL OR COKE

These fuels are composed largely of carbon which burns as a solid while supported by the grates. Temperatures in the combustion chamber and the combustion taking place in that part of the furnace are relatively unimportant. These fuels may be spread uniformly over the fuel bed when fired. At least 2 inches of ash should always cover the grates.

### FIRING WITH BITUMINOUS COAL

When heated, this fuel liberates gases which should be burned in the combustion chamber. After giving up these gases, the remaining coke burns on the grates. To spread fresh coal of this kind uniformly over the fuel bed would cover all of the live coals and reduce the temperatures in the combustion chamber. Furthermore, practically all of the fresh coal would be heated immediately and large quantities of the liberated gases would leave the furnace unburned. Fig. 8 shows how the freshly fired coal may be located in the furnace to produce better results. With this arrangement of the fuel bed, gases are driven from the fresh coal more slowly, and temperatures in the combustion chamber may be higher. At the time of the next firing, the live coals in the back part of the firepot will have burned down. The grates may be shaken until the first indication of burning particles falling to ashpit is noted. The few coals remaining in the back of the firepot are pulled forward with the poker and the fresh coal is banked in the back of the firepot.

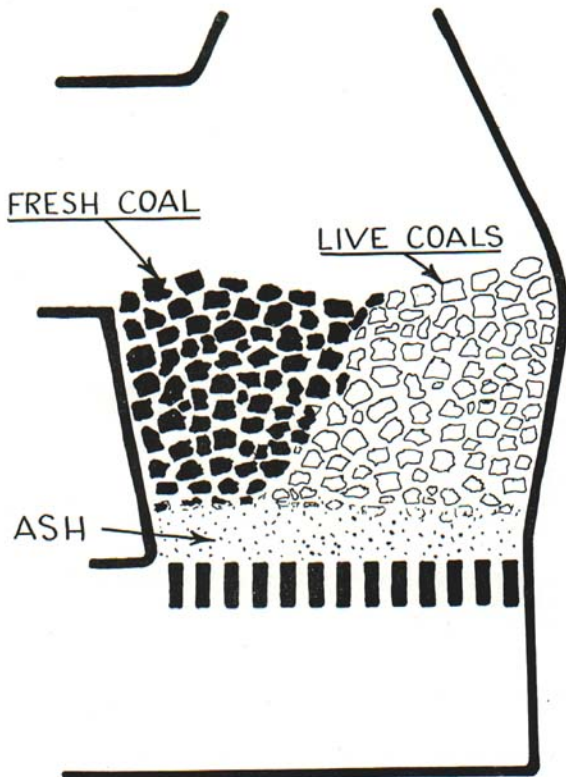

Fig. 8. Location of freshly fired bituminous coal in a furnace.

Some secondary air will be required at all times. The smoke seen coming from the chimney should be somewhat of a guide to the operator in regulating the secondary air. Too much secondary air will cool the combustion chamber and increase the heat lost through the smoke pipe, while too little will not replenish the oxygen in the combustion space and will increase the loss due to unburned fuel leaving the furnace through the smoke pipe.

The thickness of the layer of ash on the grates and the thickness of the fuel bed will have to be varied as the weather changes. The

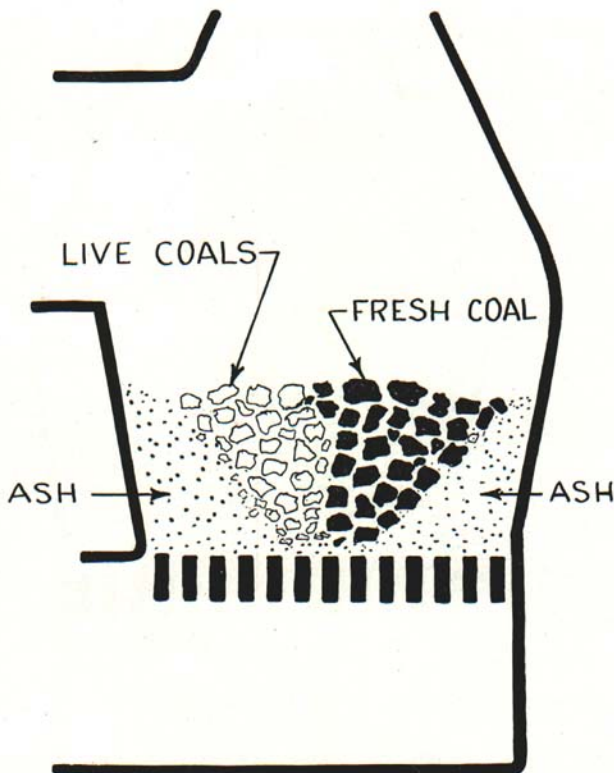

Fig. 9. Arrangement of the fuel bed in a furnace for mild weather.

thickness of the fuel bed will also have to be governed by the size of the coal particles and the draft that is available. Figure 9 shows an arrangement for the ash, fresh coal, and live coals which is suitable for mild weather firing. It will be noted that a smaller grate area is made use of and less coal is fired at a time.

#### REMOVAL OF ASHES

Professor Kratz and associates of the University of Illinois<sup>7</sup> recom-

<sup>7</sup>Kratz, A. P., Fellows, J. R. and Miles, J. C., *Hand Firing of Bituminous Coal in the Home*. University of Illinois Engineering Experiment Station Bulletin, Circular Series No. 46, 1942, 36 pages. (Not free)

mend that ashes should never be permitted to fill the ashpit to a height greater than one-half the ashpit's depth. Where ashes are permitted to accumulate to greater depths, overheating and damage to the grates often occurs. To avoid dust at the time of removal, some means should be employed to dampen or wet the ashes before they are handled with a shovel. Three methods which are used in wetting the ashes are as follows:

1. The ashes lying in ashpit may be hollowed out so as to form a basin. Pour water in the hole and allow to stand several hours before the ashes are removed.
2. If the ashpit has a bottom which is water tight, pour some water in it. Shake ashes down into the water and remove several hours later.
3. Install spray nozzles in the ashpit.

#### FIRING WITH WOOD

The moisture in wood fuel may be equal to 50 percent of the fuel's weight for green wood. The volatile matter which heat drives from the wood to burn as gases is about 40 percent of the weight and carbon is about 10 percent.<sup>8</sup>

The combustion process may be considered to take place in three, but not distinctly separate, steps. First the moisture evaporates, next the volatile matter is driven from the wood and following this the carbon is burned as charcoal. Heat must be supplied by the burning of the wood to evaporate the moisture. The steam so formed goes out the smoke pipe as a heat loss which could be eliminated to a large extent by permitting the wood to dry before it is used as a fuel.

The wood should be placed in the furnace so that the primary air will not find large holes to travel through. The draft or suction of the chimney should be regulated by the check damper or a balanced damper as shown in Fig. 13, to as low a value as practicable to give the desired combustion. Secondary air may be required in larger amounts than for bituminous coal.

When wood chunks are used in a furnace designed to burn coal and having a round grate, it is usually difficult to keep the grate surface covered uniformly with the burning fuel. Large holes through the fuel bed allow the passage of needless amounts of primary air

<sup>8</sup>Kreisinger, Henry, *Combustion of Wood Waste Fuels*, Mechanical Engineering, February, 1939, p. 115.

through these openings, whereas the areas on the grates which are covered with fuel may be in need of more air for combustion. To remedy this condition, the wood fuel might be supplemented with some coal. With coal not available, the grate surface nearest each side of the firepot might be kept covered with some noncombustible material.

#### STOKERS, GAS AND OIL BURNERS

For the owner to obtain the greatest possible benefit in heating comfort and savings in fuel from these units, he should follow the recommendations of the manufacturer of the unit in regard to operating, servicing, and the type of fuel used.

The combustion efficiency should be checked by a reputable heating contractor or service man who has the instruments and technical information this kind of work requires.

#### AUTOMATIC CONTROLS

##### ADVANTAGES

1. Save trips to the basement.
2. Save fuel by preventing overheating of the house and overheating of the furnace.
3. Keep the temperature in the house more even and therefore, more generally comfortable and healthful.
4. Prevent damage to the heating equipment due to overheating, lack of water, or high pressures.
5. An overheated furnace or smoke pipe is a fire hazard. Therefore, the controls protect the house against fire.

##### THERMOSTATS

Thermostats or control instruments which are sensitive to a change in temperature often employ two metals which are known to expand or contract unequally with a change in temperature. Each metal is formed into a thin strip and the two are bonded together to form what is called a bimetallic strip. The bimetal may be used as a straight strip or may be curved as shown in Fig. 10 (a). Owing to the unequal expansion of the two metals in the bimetallic strip, a movement is produced which affords sufficient power to open and close contact points in an electric circuit.

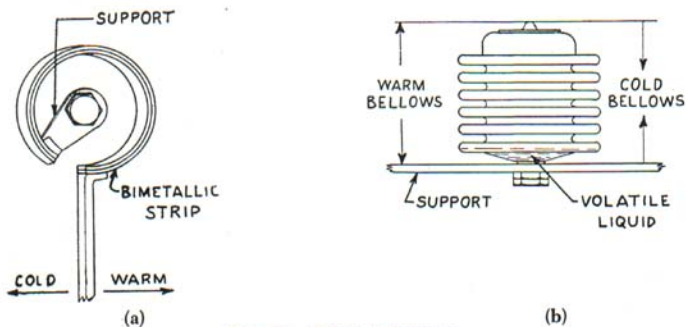

Fig. 10. Control elements.

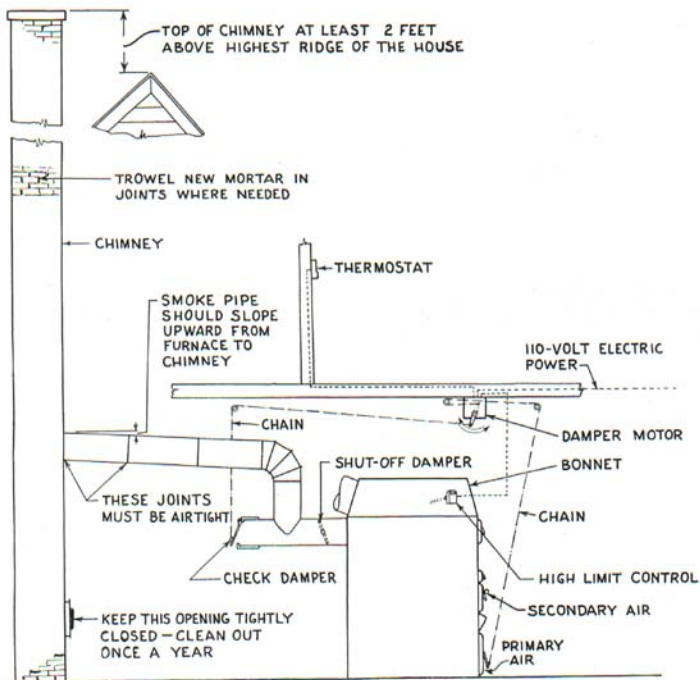

Fig. 11. Draft: Its maintenance and control.

Other thermostats use a thin brass diaphragm or the accordion bellows as the element responding to temperature changes. In either the diaphragm or the bellows a small amount of some liquid which has a low boiling point is introduced and the unit is sealed. Changes in temperature cause either more of the liquid to vaporize with a corresponding elongation of the bellows or some of the liquid to condense, which reduces the pressure in the bellows, causing it to contract as shown in Fig. 10 (b). These elements furnish sufficient power to actuate contact points in an electric circuit, open and close small valves or dampers.

#### APPLICATION TO WARM AIR SYSTEMS

The average hand-fired gravity warm air furnace should have a set of controls consisting of a room thermostat, a damper motor and a high limit control for the furnace bonnet temperature as shown in Fig. 11.

The operation of this control system is as follows:

The room thermostat causes the damper motor to change the setting of the primary air and check dampers in accordance with the temperature demands in the house. The high limit control causes the damper motor to move the dampers so as to check the fire when the bonnet temperature becomes too high for safety.

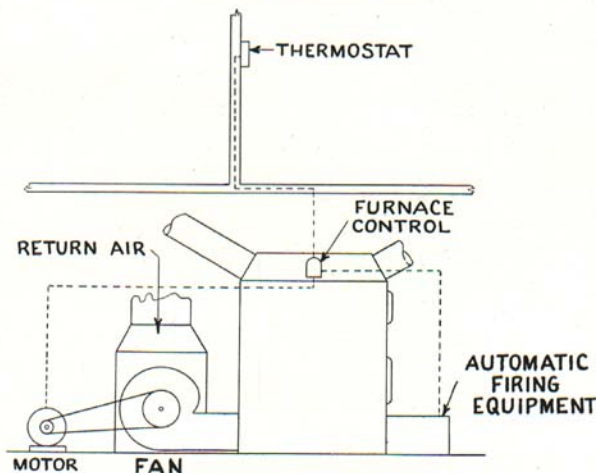

Fig. 12. Control system for automatically fired furnace using a fan.



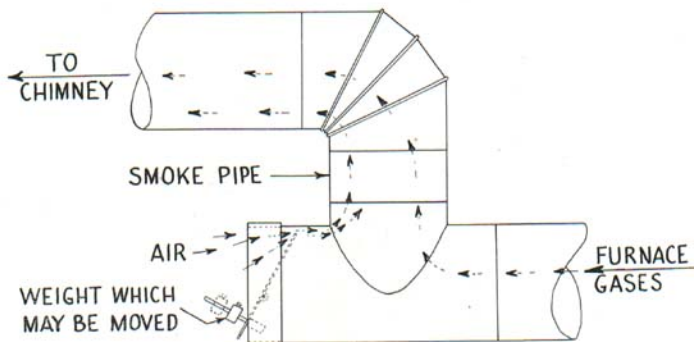

Fig. 13. Balanced damper.

Such a set of controls may save 20 per cent of the fuel ordinarily burned during the heating season.

Where the warm air furnace is provided with a blower and is fired with a stoker, oil burner or a gas burner, the system of controls shown in Fig. 12 is often used.

The operation of this system is as follows: The room thermostat starts and stops the automatic firing equipment to suit the temperature demands in the house. The furnace control is a combination unit which starts the blower when the bonnet temperature has risen to the set value, and in addition, it will stop the automatic firing equipment if the bonnet temperature becomes too high for safety.

#### HOT WATER AND STEAM BOILERS

These boilers may have the dampers positioned by a damper motor which is under the control of a room thermostat as used with the warm air system. A limit control is employed to cause the damper motor to check the fire when excessive water temperatures or steam pressures are reached. Steam boilers should be protected by an additional control device which will check the fire when the water level in the boiler is dangerously low.

#### CONTINUOUS AIR CIRCULATION (C-A-C)

Forced warm air winter air conditioning systems may be adjusted to provide continuous air circulation when the control arrangement is of the type where a) the room thermostat controls the fire, and b) the

blower control (fan switch) in the furnace bonnet or warm air plenum controls the blower operation.

The C-A-C adjustment procedure consists of adjusting the thermostat for maximum sensitivity; setting the blower control and motor pulley so that the blower runs most of the time in mild weather and practically all of the time when the outside temperature is freezing or colder; adjusting the limit control to prevent overruns; correcting registers (if necessary) for proper deflection; and finally, balancing the entire system to insure uniform temperatures in all rooms.

A large percentage of forced warm air heating systems are already equipped with modern controls. But they can be made to produce much greater indoor comfort by these few simple changes in control settings and blower speed.

That "hard to heat room" can, in almost every case, be completely "cured" by the continuous and almost imperceptible circulation of properly warmed air.

Any warm air heating contractor should be able to properly adjust a forced warm air system for continuous air circulation.

#### BALANCED DAMPERS

These devices assist in keeping the draft or suction of the chimney more uniform. They may be used in the place of the check damper and are recommended for installations not provided with a check damper. Fig. 13 shows the principle of operation for a balanced damper.

### CLEANING AND REPAIRS

#### SMOKE PIPE AND CHIMNEY

These parts of the heating plant should be examined for possible air leakage and need for cleaning about once a year. In addition to the points suggested in Fig. 11 the chimney flue should be freed of any obstructing matter such as a loose piece of the tile lining.

#### WARM AIR SYSTEMS

Deposits of soot in the furnace should be removed with a wire brush which is obtainable through dealers in heating supplies.

The odor of furnace gases in the house and rather active burning of the fuel in the furnace when the primary air damper is closed are indications of air leakage through the walls of the firepot and the com-

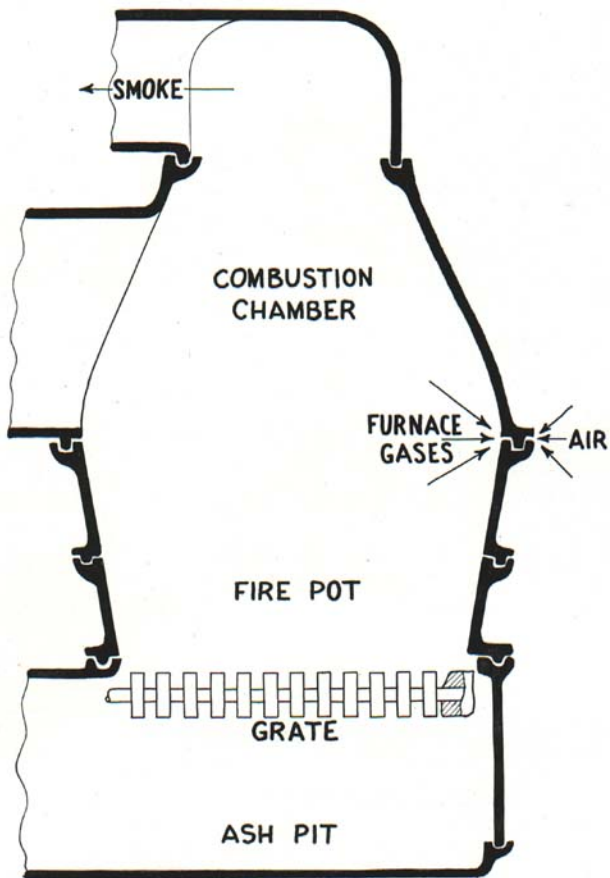

Fig. 14. Gas leakage through the wall of a cast iron furnace.

bustion chamber. Fig. 14 shows a sectional view of a cast iron furnace with the outer steel jacket removed. The tongue and groove joints in the entire wall surface may be seen. When a furnace is set up, these joints are filled with furnace cement. After a period of service, the joints may develop leaks as indicated, requiring that the

cement be replaced. After long service, cracks may develop in the metal forming these parts of the furnace, particularly around the fire-pot, and the broken part will have to be replaced. The pan in which water is evaporated for humidifying purposes should be cleaned out as required.

Air filters in the fan compartment should be inspected at 1- or 2-week intervals during the heating season for need of cleaning or replacement. Long periods of running of the furnace fan with little air delivery from the warm air registers are an indication of dirty filters. Fan blades should also be inspected and cleaned. Heating contractors or dealers in heating supplies are usually able to offer furnace cleaning service.

#### STEAM AND HOT WATER SYSTEMS

Soot deposits should be removed from the heating surface of the boiler through the use of a wire brush.

Leaks in the boiler, the piping system, or around the radiators should be repaired.

Pockets or low points in the piping system, from which water will not drain back to the boiler, should be sought out and eliminated. Insulation in the form of asbestos cement or 85 percent magnesia blocks should be applied to the boiler. Hot water and steam piping in the basement should be covered with insulation.

It is suggested that a heating contractor be employed to assist in finding and correcting defects in these heating systems.

#### SAVING FUEL<sup>9</sup>

##### WHAT SHOULD BE DONE TO THE HOUSE

- (A) Insulate ceiling. A 3½-inch thickness of fill insulation saves from 362 to 495 pounds of coal a year for each 100 square feet of ceiling area.<sup>10</sup>
- (B) Install storm windows and storm doors. Each 100 square feet of storm window or storm door saves 1480 to 2020 pounds of coal a year on average window or outside door.

<sup>9</sup>War on Fuel Waste. War Service Committee, American Society Heating and Ventilating Engineers, 1942.

<sup>10</sup>See Table 2, page 17.

- (C) If weatherstripping is installed with storm windows and storm doors, savings will be 1800 to 2450 pounds of coal a year for each 100 square feet of window or outside door area. If windows are loose fitting, the savings will be greater.
- (D) Insulate outside walls. A 3½-inch thickness of fill insulation saves from 285 to 388 pounds of coal a year for each 100 square feet of wall area.

#### WHAT SHOULD BE DONE TO THE HEATING PLANT

##### FURNACES AND BOILERS

- (A) Remove all soot on the furnace or boiler's heating surface. Use a wire brush. May save 5 percent of fuel.
- (B) Take down smoke pipe and remove soot. Replace, making joints air tight.
- (C) Clean out bottom of chimney flue, close any air leaks into chimney. Remove any obstructions from chimney flue.
- (D) If stoker or oil burner, have the combustion efficiency checked by a reliable heating contractor. Follow directions of the manufacturer.
- (E) If hand fired, install room thermostat and damper motor to prevent overheating of the house. These units may save anywhere from 5 to 20 percent of the fuel used during a heating season.
- (F) Steam and hot-water boilers should be insulated. Also, should be flushed out once a year and refilled with soft water.
- (G) Warm air furnaces should be inspected for air leakage around firepot and combustion chamber. Repair leaks with furnace cement and replace cracked or burned-out parts.

##### WARM AIR SYSTEMS

- (A) Inspect air filters in the fan compartment at 1- or 2-week intervals for need of cleaning or replacement.
- (B) Inspect fan blades for need of cleaning.
- (C) Install high limit control for furnace bonnet temperature. These units save fuel by preventing excessive losses of heat through the smoke pipe and excessive radiation losses from furnace. Prevents damage to furnace and protects house against fire.
- (D) Remove obstructions from warm-air and return-air pipes.

## HOT WATER AND STEAM SYSTEMS

- (A) Have heating contractor examine piping system for improper connection, water or air pockets, leaks, and proper sloping; also, for need of insulation.
- (B) Clean out bottoms of radiators with a long handled wire brush.
- (C) Open steam traps on radiators. Clean parts where needed. Use wire brush and kerosene.
- (D) If radiators are concealed, inspect for need of cleaning on the outside. Remove lint or other materials which may interfere with circulation of air over heating surface.

## WHAT THE OCCUPANTS OF THE HOUSE SHOULD DO

- (A) Turn the room thermostat down 8 or more degrees as early in the evening as practicable. Savings in fuel may amount to 8 or 10 percent.
- (B) Remove furniture or draperies which interfere with the circulation of air around the radiators. Do not permit rugs to cover return-air registers.
- (C) If the bedroom windows are kept open while sleeping, close bedroom door and turn off the heat.
- (D) Unused parts of the house should not be heated. Also, close draperies or French doors leading to the sun room. Keep heat in sun room turned off.
- (E) Draw draperies or window shades over cold window glass when practicable.
- (F) Keep damper in fireplace closed to avoid leakage of warm air up the chimney. In case the fireplace has no damper, close the front of the fireplace with a closely fitted cover.
- (G) If furnace is fired by hand:
  1. Place fresh coal either in the back or in the front of the firepot. Never cover all of the live coals in the furnace with fresh bituminous coal.
  2. Always keep at least 2 inches of ashes on the grates.
  3. Stop shaking grates when first burning particles fall into the ashpit.

## SUGGESTED READING

The following books may be found in libraries and are suggested to those readers who may wish more information:

*Heating, Ventilating, Air Conditioning Guide*, New York American Society of Heating and Ventilating Engineers, Published annually.

Close, P. D. *Building Insulation*, Chicago, American Technical Society, 1942.

Konzo, S. *Winter Air Conditioning Forced Warm Air Heating*, Cleveland 14, Ohio, National Warm Air Heating and Air Conditioning Association, 1939.

Harding, L. A. and Willard, A. C. *Heating, Ventilating and Air Conditioning*, 1932.

Names and addresses of publishers of the foregoing material will be supplied upon request.

Cooperative extension work in agriculture and home economics, Michigan State College and U. S. Department of Agriculture cooperating. C. V. Ballard, Director, Cooperative Extension Service, Michigan State College, East Lansing. Printed and distributed under acts of Congress May 8 and June 30, 1914.

10M-June 1949