

**REFRIGERATION and  
CONTROLLED ATMOSPHERE  
STORAGE for Horticultural Crops**



## AUTHORS

James A. Bartsch, Dept. of Agricultural Engineering, Cornell University  
G. David Blanplied, Dept. of Pomology, Cornell University

The Northeast Regional Agricultural Engineering Service (NRAES) is an official activity of 13 Land-Grant Universities and the U.S. Department of Agriculture. The following are cooperating members:

University of Connecticut Storrs, CT 06268	Cornell University Ithaca, NY 14853
University of Delaware Newark, DE 19711	Pennsylvania State University University Park, PA 16802
University of Maine Orono, ME 04469	University of Rhode Island Kingston, RI 02881
University of Maryland College Park, MD 20742	University of Vermont Burlington, VT 05405
University of Massachusetts Amherst, MA 01003	West Virginia University Morgantown, WV 26506
University of New Hampshire Durham, NH 03824	University of the District of Columbia Washington, DC 20004
Rutgers University New Brunswick, NJ 08903	

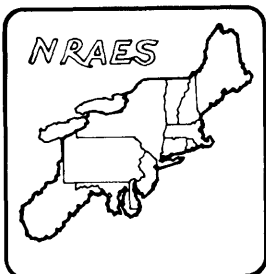

## NRAES-22

For additional copies of this book, write to:  
Extension Agricultural Engineer at any of the above institutions, or  
NRAES, Riley Robb Hall, Cornell University, Ithaca, NY 14853

# Refrigeration and Controlled Atmosphere Storage for Horticultural Crops

## CONTENTS

<b>CONSTRUCTION</b> .....	2
Site Selection, Structural Considerations, Thermal Insulation, Vapor Barriers, Attic Ventilation	
<b>REFRIGERATION</b> .....	6
Types of Systems, Relative Humidity, Load Calculations, Compressors, Rate of Cooling, Operating Procedures, Refrigerated Bulk Storage	
<b>CONTROLLED ATMOSPHERE STORAGE</b> .....	19
Construction, Pressure, Tests, Equipment, Operation	
<b>APPENDIX I - Load Calculation Example</b> .....	35
<b>APPENDIX II - CA Safety Precautions</b> .....	36
<b>APPENDIX III - Use of the Orsat Analyser</b> .....	38
<b>APPENDIX IV - Pressure Test Data Sheet</b> .....	41
<b>REFERENCES</b> .....	42

Refrigerated storage extends the period of acceptable eating quality of perishable seasonal products. Eating quality of many horticultural crops increases after harvest and then rapidly diminishes if cold storage is not used. Proper storage will reduce the rate of postharvest senescence and deterioration and provide a high quality product for extended periods (Figure 1).

The lower temperature in refrigerated cold storage slows the rate of product metabolism reducing respiration and losses of flavor, texture, color, etc. Successful long term storage requires that the rate of metabolism be maintained at minimal levels to sustain cell life but reduced to

a point where the eating quality can be extended for the duration of the storage period.

Metabolic processes of the stored products can also be retarded by reducing the amount of oxygen and increasing the carbon dioxide content of the storage atmosphere. In controlled atmosphere (CA) storage the rate of product metabolism is reduced by lowering the temperature and oxygen concentration and raising the carbon dioxide concentration in the storage atmosphere. CA storage reduces the respiration rate approximately 50% compared to air storage at the same temperature.

**Figure 1.** Influence of Various Postharvest Storage Systems on the Eating Quality of Horticultural Products

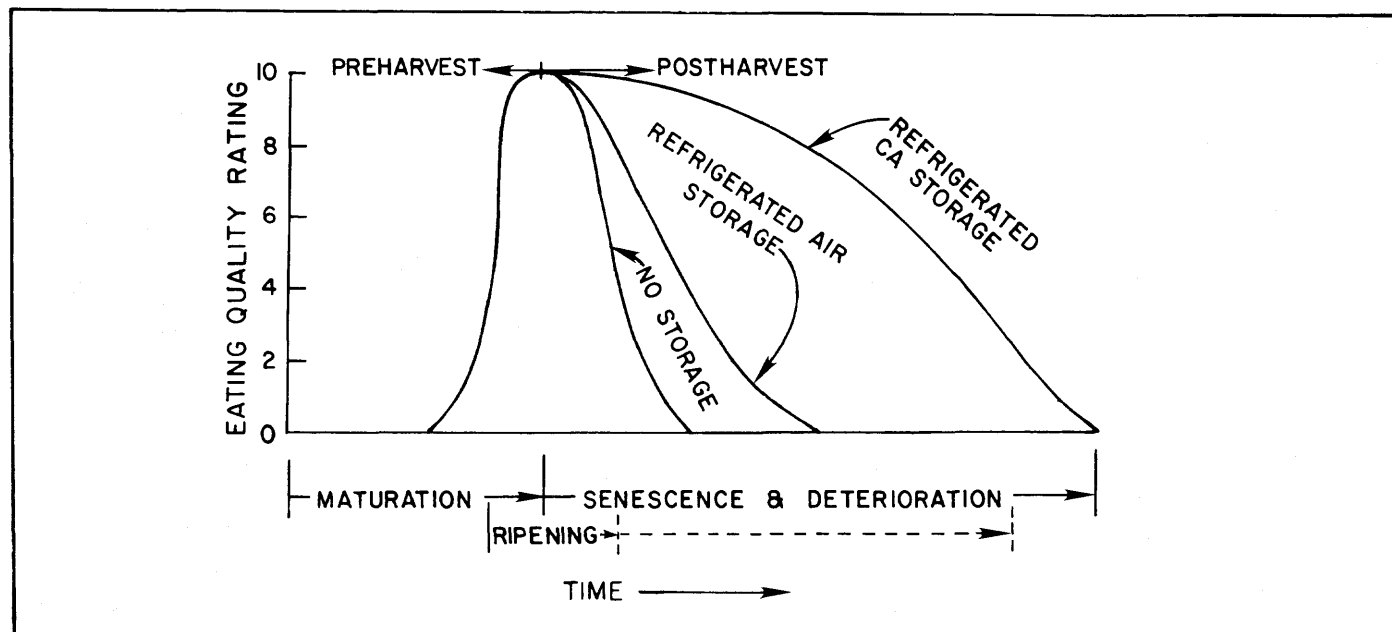

# Construction

## Site Selection

In selecting a building location for a new storage facility, consider:

- **Drainage.** Only consider a site that can be well drained by grading, ditching and/or subsurface drains. Ideally site topography permits flow of water away from all paved and graveled surfaces as well as from roof, foundation, and loading dock drains. In locations with heavy snow fall, choose a site to facilitate snow removal.
- **Availability of Utilities.** Three-phase electrical power must be available. The water supply must be adequate for condenser cooling and domestic needs. Gas or sewer service, fire protection, property security and worker safety also influence the choice of the building location.
- **Expansion.** Plan for the future when undertaking any construction and renovation project. Allocate space for future packing facilities, expanded cold storage capacity, larger parking, shipping and receiving areas, and increased dry storage capacity for empty bins when construction plans are first drawn. The distance to present and future roads, streams, property lines and utility rights-of-way should all be considered when plans for present and future space utilization are drawn.

## Structural Considerations

Many types and configurations of buildings are suitable for cold storage. Early storages in the Northeast were wood frame construction and a few small units of this type are still being built. Wood pole and post construction is frequently used for large capacity refrigerated vegetable and processing fruit storage. With careful adaptation these pole buildings can also be used for successful CA storage facilities.

Steel buildings are used for both refrigerated and CA storage structures as well as for packing facilities. Large commercial CA storage systems are commonly built of concrete block or precast concrete panel construction. In the Northeast, unlike the Western United States, cast-on-site, tilt-up concrete construction is not commonly used, even though it is well suited for cold storage.

With proper design and careful construction virtually any

type of building will function well as an efficient cold storage. Tight controlled atmosphere rooms are easier to obtain in buildings which have smooth interior walls and ceilings. Steel and timber post buildings are easier to seal if an interior skin of wood or metal is installed before the gas seal and thermal insulation is applied.

Structural provisions should be made for the support of ceiling mounted evaporators. These units may weigh in excess of 2000 pounds, so special load sharing members may be needed in the roof trusses or rafters.

## Thermal Insulation

Once the site has been chosen and the building plan has been determined, the amount and type of insulation material must be selected to enclose the cold storage volume. Refrigerated and CA storages which are operated through the fall, winter and spring in the Northeast need a minimum of R-10 in the floor, R-20 in the walls and R-30 in the ceiling. If the storage is going to be operated on a year-round basis, the R value of each surface should be increased by 5 units to R-15, R-25, and R-35. Cold rooms operated during the summer only are most efficient if higher insulation values are used. Current ASHRAE recommendations for summer conditions are an R-20, R-30 and R-40 for floor, wall and ceiling values respectively.<sup>1</sup> Prefabricated coolers insulated with urethane will have an approximate R value of 30 in a 4" thick panel.

The R value of insulation is a measure of its resistance to heat flow. The higher R values indicate greater resistance to heat flow and better insulating characteristics. Determine the effectiveness of an insulation material or a composite structure of several materials by summing the R factors for each unit of the material in the composite structure.

The R values of many common construction and insulating materials are presented in Table 1. The manufacturers of specific insulating materials state the actual R values of their products so the table presented here should be used as a general guide.

<sup>1</sup>The ASHRAE Handbook of Fundamentals. American Society of Heating, Refrigeration and Air-Conditioning Engineers Inc., 1791 Tullie Circle, Northeast, Atlanta, GA 30329.

**Table 1.** Thermal Properties of Selected Insulating and Building Materials

Material	R Factor	
	Conventional or English Units (hrft <sup>2</sup> °F)/Btu	Metric <sup>1</sup> Units (m <sup>2</sup> °K)/W
<b>Insulation:</b>		
Fiberglass batts <sup>2</sup>	3.32/inch	.230/cm
Fiberglass, loose	2.55/inch	.177/cm
Fiberglass, board	4.00/inch	.277/cm
Cellular glass (Foamglas)	2.86/inch	.198/cm
Styrofoam, extruded	5.26/inch	.346/cm
Styrofoam, beadboard <sup>3</sup>	4.17/inch	.289/cm
Polyurethane, board	6.25/inch	.433/cm
Polyurethane, foamed-in-place	6.25/inch	.433/cm
Polyisocyanurate, board	7.04/inch	.488/cm
<b>Building Materials:</b>		
Fir plywood	1.25/inch	.087/cm
Fiberboard sheathing 1/2"	1.32	.233
Particle board 1/2" (Aspenite)	0.92	.162
Gypsum board (5/8")	0.56	.099
Concrete, cast	0.11/inch	.008/cm
Concrete block 8"	1.11	.195
Concrete block 12"	1.28	.225
Glass, single pane	0.10	.018
<b>Fire Coatings for Foam:</b>		
Perlite-Gypsum Plaster (1/2")	.33	.058
Vermiculite-Gypsum Plaster (1/2")	.30	.053
Fire retardant Cellulose (1")	4.00	.71
<b>Air Film and Air Gaps:</b>		
Air Film, outside summer or inside heated	.28	.044
Air Film, outside winter or inside cold storage	.17	.030
1 inch or greater air gap (average value)	.72	.127

<sup>1</sup>Metric Conversion factors: [(hrft<sup>2</sup>°F)/Btu] \* 0.176 = (m<sup>2</sup>°K)/W  
 inches \* 2.54 = cm  
<sup>2</sup>Unfaced, average value for several types  
<sup>3</sup>1.5 lb/f<sup>3</sup> (0.024g/cc) density

Calculate the average insulating value (R value) of a composite wall or floor or ceiling by multiplying the unit values in the table by the thickness of each component actually used in the wall, ceiling or floor. Where several materials are used, the R value for each material can be added to that of other materials in the structure and the composite R value for the whole structure can be determined. In addition to the insulating value provided by the construction and insulation materials, a small amount of thermal resistance is also credited to the air film on the surface. These air film data are also given in Table 1.

**Example:**

The R value for the wall section shown in Figure 2 can be determined using the thermal properties data in Table 1.

Component (See Figure 2)	R Value
Outside (summer) Air Film	0.28
8" Block Wall	1.11
3" Urethane (3" x 6.25/inch)	18.75
1/2" Firecoat (Perlite/Gypsum)	0.33
Inside (cold) Air Film	0.17
<b>Total for Wall</b>	<b>20.64</b>

**Figure 2.** Insulated Wall Section of Cold Storage

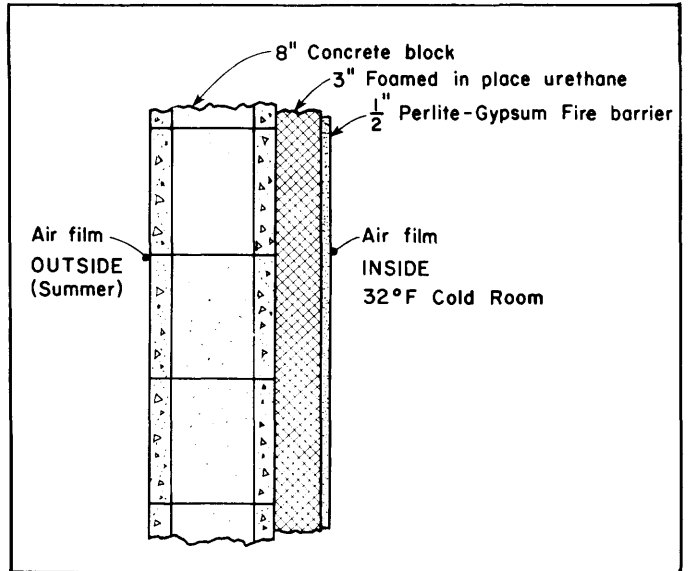

Note that three inches of urethane accounts for over 90% of the total insulating value for this wall and that the 8" block provides only 5% of the total.

The amount of insulation required to provide a desired R value may be computed by totaling the R values of the individual materials and then subtracting this value from the desired level. The values listed below are for the components shown in Figure 3.

Component	R Value
Inside (cold) Air Film	0.17
5" Concrete (5" x 0.11/inch)	0.55
Subfloor Insulation (Extruded Polystyrene)	9.28
Vapor Barrier (6 mil polyethylene)	0.00
<b>Total Desired for Floor</b>	<b>10.00</b>

**Figure 3.** Insulated Floor Section of Cold Storage

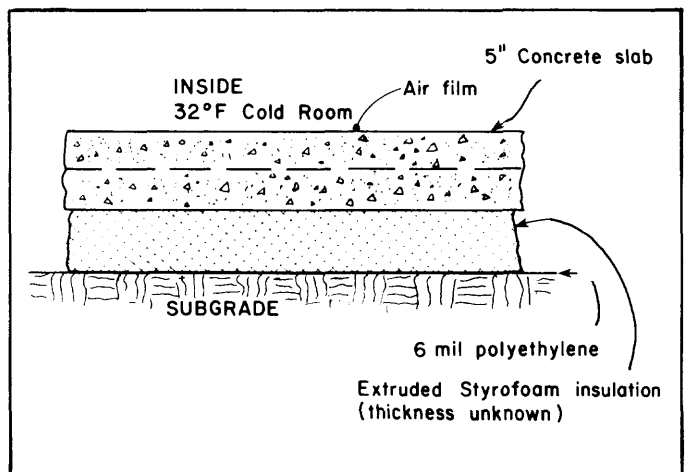

The desired R value for subfloor insulation is  $10.00 - (0.17 + 0.55) = 9.28$ . The thickness of extruded Styrofoam needed is  $(9.28/5.00 \text{ per inch}) = 1.86$  inches. Because boards of standard thickness will be used, 2 inch thick board stock would be selected for the floor insulation system. The actual R value in this floor would be 10.72. Note again the very small contribution the 5 inch concrete slab makes toward the total insulation value of the floor.

## Vapor Barriers

A vapor barrier prevents moisture from collecting within insulated spaces in walls and ceilings. Porous insulating materials like fiberglass and cellulose quickly become waterlogged and lose their insulating value if a vapor barrier is not installed. Ultimately it can cause structural damage due to rotting of wood or rusting of metal. Damage often becomes serious before the symptoms are even discovered.

Install a continuous vapor barrier, such as 6 mil polyethylene film to protect loose fill (cellulose and fiberglass) or porous board (beadboard or fiberglass board) insulation materials. Install it on the warm side as shown in Figure 4.

The warm side of a cold room is the outside since the room is maintained at below ambient temperatures during most of the storage season.

Seal hanger rods and other attic penetrations at the vapor barrier junction. Also insulate these members on the attic side to prevent surface condensation and moisture accumulation around the metal fixtures. Heated spaces such as offices and packing rooms must have a vapor barrier on the inside wall and ceiling surface because the inside temperature is higher than the surrounding environment.

Rigid board material like extruded polystyrene (Styrofoam) and polyisocyanurate absorb almost no water and, therefore, create little risk of wood rot or metal corrosion. It is still necessary to install a vapor barrier because joints between slabs and spaces between framework and insulation permit moisture migration.

Do not use porous board and absorbent loose fill insulation materials (e.g., bead and fiberglass board, loose fill cellulose) for CA construction. These materials must never be enclosed between an external vapor barrier and the internal gas seal. This type of CA construction has proved unacceptable because moisture has become trapped in the insulation between the two impervious layers and structural damage has resulted. This problem

Figure 4. Vapor Barrier Location and Methods of Ventilating Attics

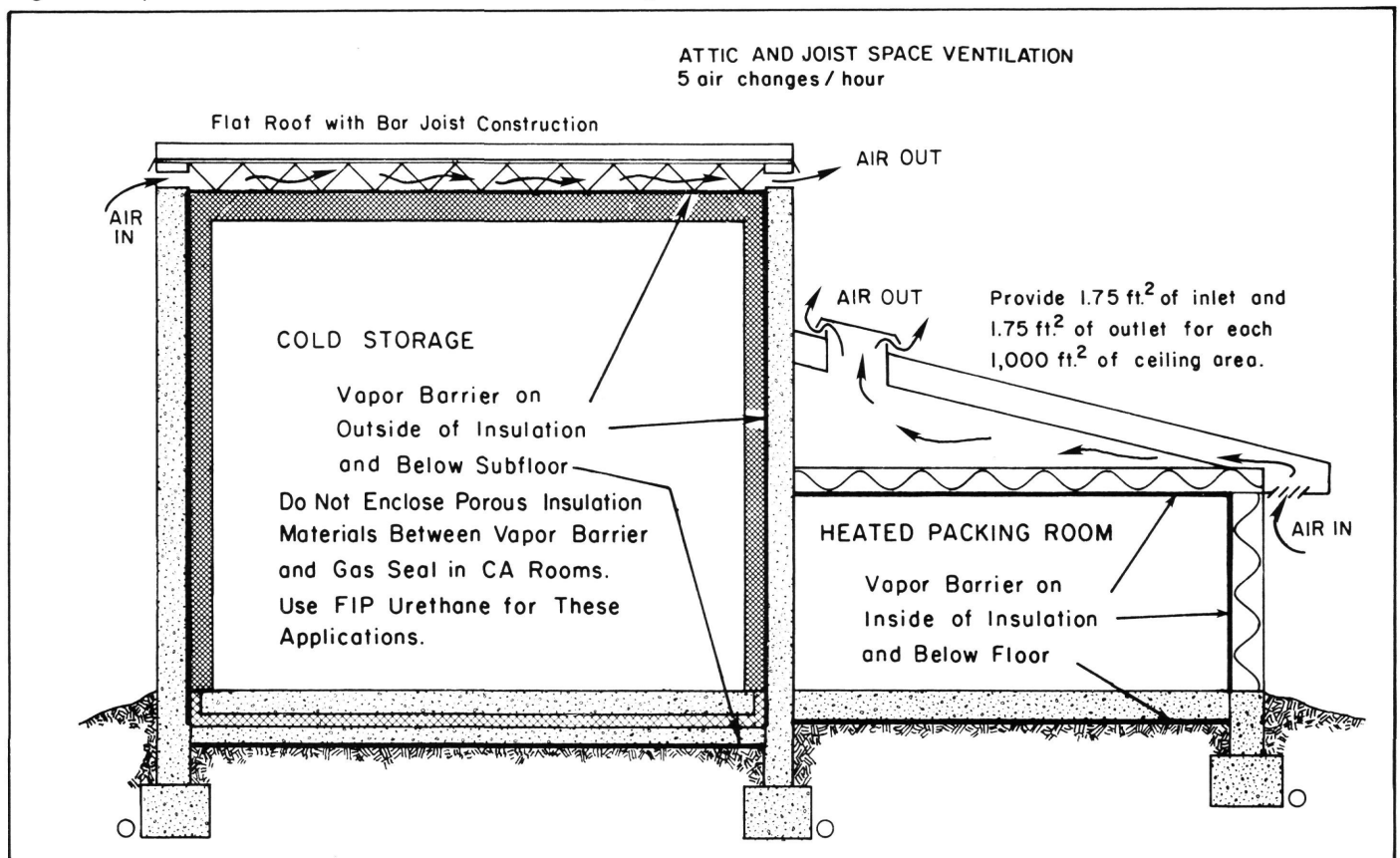

is common in old refrigerated installations which were converted to CA storage and in CA rooms built before foamed-in-place urethane was available.

Do not convert old cold rooms insulated with cork, sawdust, Vermiculite, etc. to CA storage unless the insulation is replaced. If insulation materials like fiberglass, cellulose and Styrofoam beadboard are used in CA construction, the insulation should be placed inside the gas seal. When this is done, the gas seal serves as the vapor barrier and the potential for moisture migration and structural damage is eliminated. The method is not popular because these types of insulation are very fragile and vulnerable to damage when left exposed. Another major drawback is that leaks in the gas seal are virtually impossible to locate when the insulation is placed inside the CA room.

Foamed-in-place (FIP) polyurethane in CA construction practically eliminates the problem of condensation, wet insulation and structural damage. FIP urethane is especially well suited to CA storage where an outside surface vapor barrier is needed but an inside surface gas seal is desired. All FIP urethane should be protected with a fire

barrier which complies with appropriate insurance underwriters' and local building codes. Keep the fire barrier dry at all times or it may separate from the foam.

Place a polyethylene vapor barrier under poured concrete floors and subfloors as shown in Figure 4.

## Attic Ventilation

---

Attic ventilation keeps moisture from accumulating under the roof. Spaces under flat roofs may be passively ventilated as shown in Figure 4 or mechanical ventilation may be installed to improve air exchange efficiencies. Gable and shed roofs over cold rooms and packing houses can usually be handled by a passive system composed of soffit and ridge vents as indicated.

A passive system requires 1.75 square feet of ventilation inlet and outlet area for each 1,000 square feet of ceiling area to be effective. Design power ventilation systems to provide four to five air changes per hour. The core spaces in precast concrete roof and ceiling panels are not normally ventilated.



# Refrigeration

## Types of Refrigeration Systems

Two types of refrigeration systems are commonly used in present day perishable product storage. The most common type is a direct expansion system shown schematically in Figure 5. Flooded systems (Figure 6) are also used for cold storage of perishables in the Northeast but their use is presently restricted to relatively few large storage facilities.

### • Direct Expansion System

In a typical direct expansion refrigeration system (Figure 5), high pressure liquid refrigerant flows through the expansion valve and "boils" under reduced pressure within the evaporator. Heat is absorbed by the evaporating refrigerant, resulting in cooling of the space surrounding the evaporator coil. The evaporation temperature is determined by the internal evaporator pressure and the type of refrigerant used (see Table 2). The rate of heat removal (Btu/hr) depends upon the refrigerant flow rate, the internal coil pressure and the surface area of the evaporator coil.

**Table 2.** Pressure-Temperature Relationships for Common Refrigerants

Refrigerant Boiling Temp. °F	Refrigerant Pressure, Pounds per Square Inch		
	Freon 12	Freon 22	Ammonia
-20	0.6	10.1	3.1
-10	4.5	16.5	9.0
0	9.2	24.0	15.7
+10	14.6	32.8	23.8
+20	21.0	43.0	33.5
+25	24.6	48.8	39.0
+30	28.4	54.9	45.0
+35	32.6	61.5	51.6
+40	37.0	68.5	58.6
+60	57.7	101.6	92.9
+80	84.2	143.6	138.3
+100	117.2	195.9	197.2
+120	157.6	259.9	271.7

erant flow rate, the internal coil pressure and the surface area of the evaporator coil.

An expansion valve divides the high and low pressure sides of the direct expansion system. In commercial systems a thermostatic expansion valve control senses the temperature of the suction line and modulates the

**Figure 5.** Schematic Representation of Direct Expansion Refrigeration System

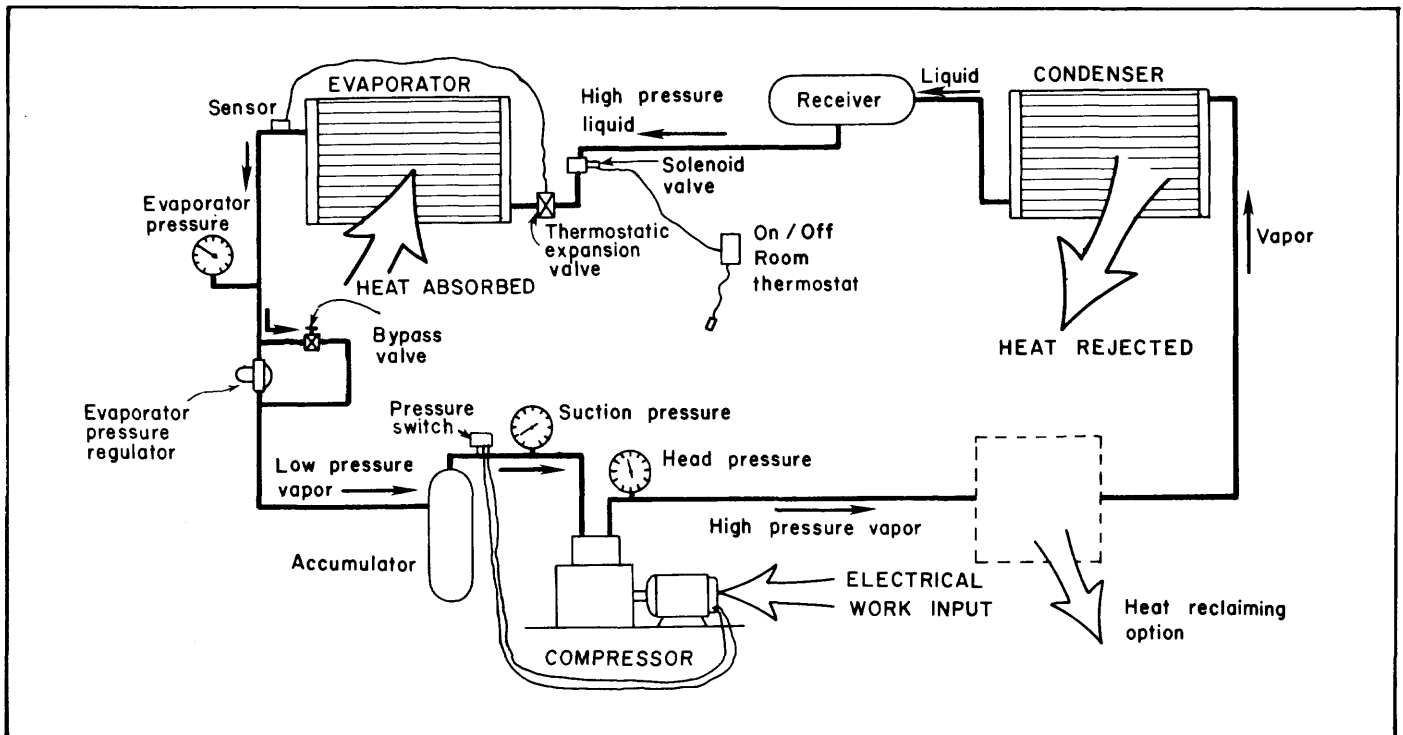

expansion valve opening. If liquid flows from the evaporator the suction line temperature sensors will detect a very cold condition and cause the expansion valve control to respond by reducing refrigerant flow. If refrigerant flow is inadequate, superheated vapor leaving the evaporator will raise the suction line temperature and the thermostatic sensor will respond by opening the expansion valve to increase the refrigerant flow. The thermostatic expansion valve is sized to match the evaporator capacity and prevent liquid refrigerant from returning to the compressor.

An Evaporator Pressure Regulator (EPR) controls the refrigerant pressure and temperature inside the evaporator (Figure 5). This device is set to maintain the desired evaporator coil temperature during long term storage. This valve is bypassed during loading to obtain additional refrigeration capacity from the evaporator. Bypassing the EPR allows the coil to operate at the low suction pressure developed by the compressor and therefore remove heat from the product at a faster rate. The EPR must be reactivated after loading and pull down so that high humidity levels can be maintained during storage. The evaporator temperature remains fixed at the corresponding pressure level setting of the EPR for the duration of the storage period.

An accumulator located between the EPR and compressor prevents liquid refrigerant from reaching the compressor. The cold, low pressure vapor from the accumulator enters the compressor where the pressure and temperature are increased. Mechanical work produced by electrical energy is required for this process. The hot, compressed vapor is then cooled in the condenser and the refrigerant returns to a liquid state. The heat gained during the compression process plus the heat absorbed during the evaporation process is rejected during condensation. Condensation occurs at temperatures in the range of 100 to 110°F making the process a potential source of reclaimable energy for such things as space and water heating.

Controls for direct expansion systems are mechanical or solid state thermostats with sensor elements located inside the cold room. When the room temperature exceeds the set point of the thermostat, the solenoid valve in the liquid line is opened and refrigerant flows through the expansion valve and into the evaporator. When the solenoid valve opens, the suction line pressure rises, activating a suction pressure switch, which starts the compressor. When the room is cooled down to the set point of the thermostat, the solenoid valve closes and the suction pressure drops and activates the pressure which shuts down the compressor. During the compressor off period, all the refrigerant is held in the high pressure liquid receiver. An optional second solenoid valve at the evaporator outlet holds unevaporated liquid in the evaporator during the compressor off period.

## ● Flooded System

In a “flooded” system (Figure 6), the evaporator is kept full of boiling liquid refrigerant supplied from the low pressure receiver. The pressure inside both the evaporator and low pressure receiver is determined by a thermostatically controlled pressure modulating regulator. Rather than turn the evaporator on or off as with the direct expansion system, the flooded system constantly varies the rate of cooling as demanded by the room thermostat. If only a small amount of cooling is required, the pressure regulating valve is only opened a small amount and the temperature of the refrigerant in the coil is maintained just a degree or two below room temperature. If the room temperature changes, the cooling rate changes proportionately.

The thermostat responds to the change in room temperature by modulating the evaporator back pressure in direct proportion to the set point and room temperature unbalance. The major difference between this system and the direct expansion system is that instead of steps of full on and full off operation, the flooded system uniformly varies the rate of cooling to match that required to maintain the room at the desired temperature level. The operation and function of the compressor and condenser units are similar in the direct expansion and flooded systems.

Heat may be reclaimed from the condenser on the flooded system. Head pressure and condenser temperatures are virtually the same for both the direct expansion and flooded systems. The quantity of reclaimable energy depends upon the cooling load and the number of units being operated.

It is possible and desirable to manifold or connect refrigeration systems together. Flooded and direct expansion systems cannot be interconnected but multiple rooms of each type can be plumbed to multiple compressors of the same system. During loading and pull down, several compressors may be needed to cool two or three rooms. After pull down, only one compressor may be needed to maintain three or four rooms. Manifolding also increases system reliability because backup equipment is always on line if a unit fails.

## ● Defrost Systems

Both direct expansion and flooded evaporators operating in rooms colder than 36°F will have to be defrosted. Brine spray (and water spray) evaporators are continuously defrosted by liquid which is sprayed over the coils. Ceiling mounted direct throw evaporator/blower units are periodically shut down and defrosted.

Warm water (60°F) pumped over the coil while the fans and refrigeration are turned off is an efficient and reliable defroster. The water and melted ice return to a sump and are reheated, and reused in the next defrost cycle. Compressor heat may be used to heat the defrost water.

**Figure 6.** Schematic Representation of Flooded Refrigerated System

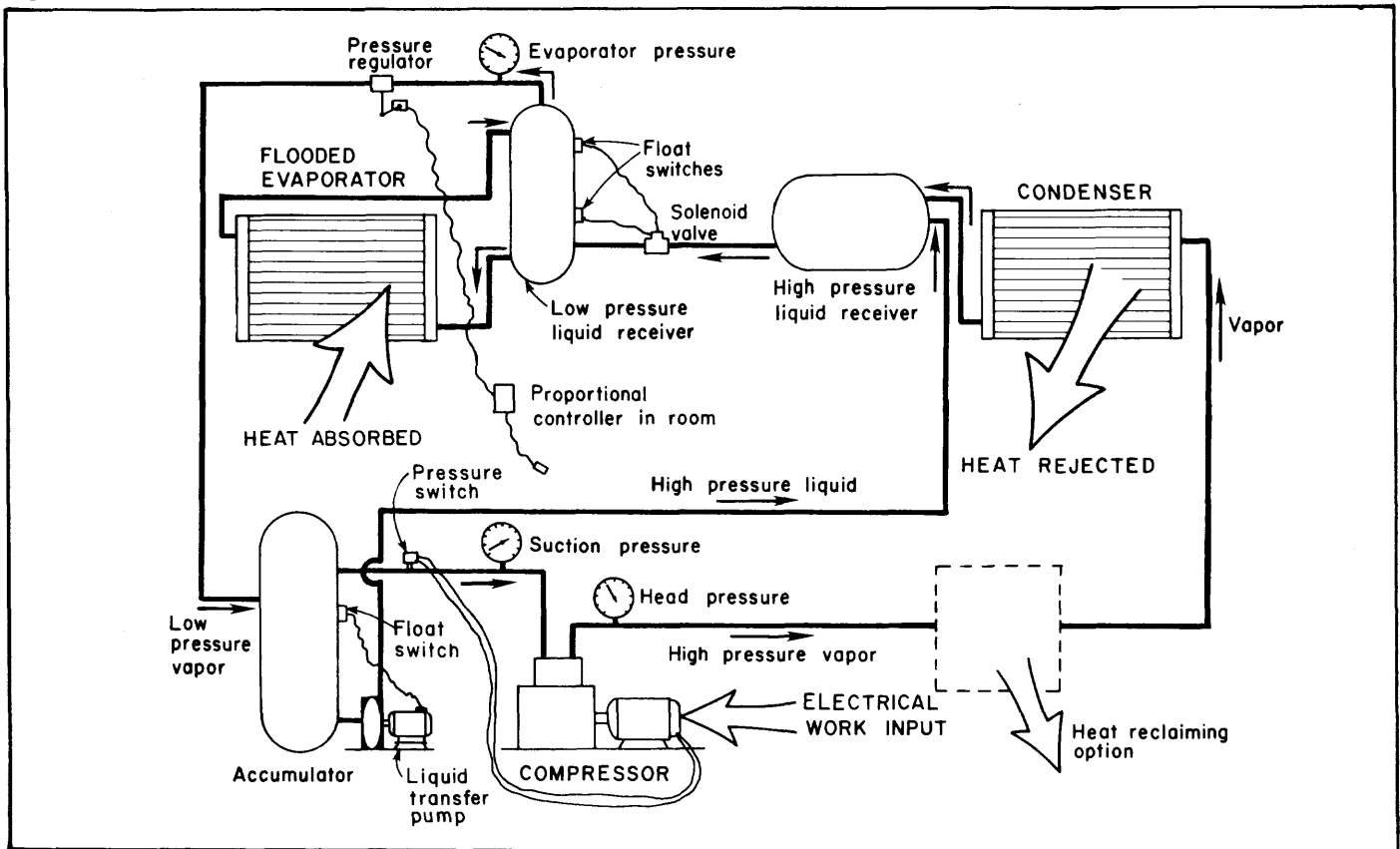

Hot gas defrost systems circulate the high temperature (100°F) refrigerant through the coil to melt the ice. With this system, fans are turned off and the refrigerant flow is altered so that the evaporators being defrosted are used as refrigerant condensers during the cycle. This method requires that a refrigeration load from another cold room (or several rooms) be available to supply heat for the defrost process. Hot gas defrost is not recommended for plants that do not have an adequate load to provide a supply of hot refrigerant during defrost. If a load is not present excessive compressor heating and partial defrosting will occur. Compressor life may be shortened as a result of this operation.

Electric defrost is convenient but expensive to operate. It is ideally suited to small installations where hot gas or warm water may not be practical. High temperature limit switches should be installed on all electric defrost systems to prevent overheating the coil after the ice is melted. This will conserve energy and prevent high pressures from developing inside the evaporator.

Regardless of the defrost system used, always operate it to remove all ice from the coil. Maximum air distribution and rapid cooling are obtained only when the coil is free of ice. Partially melted ice may refreeze and collapse evaporator tubes or deform fins, tubes and electric defrost heating elements. The frequency of defrost may be determined by observing frost accumulation on the

coil. Operate the defrost system only long enough to melt the ice; anything more will only add heat to the room.

Under CA conditions, the heat added during defrost creates a positive pressure in the room. Rapid cooling occurs when the refrigerant flow and fans are restarted after defrost, and a negative pressure develops. These pressure variations may create excess structural stress and increase air infiltration which increases the oxygen level in CA rooms. Pressure fluctuations are kept to a minimum if defrost related temperature variations are kept as small as possible.

## Relative Humidity

Water loss from the stored produce is retarded by reducing the product temperature and by maintaining a high moisture or high relative humidity storage environment. Water vapor is added to the storage atmosphere from the following sources:

- Transpiration (water loss) from inside the product
- Evaporation of surface water from the product
- Humidifiers placed in the storeroom to raise the relative humidity
- Evaporation of free water on the floor and on storage

containers, and from moisture released during evaporator defrost

Water vapor is lost from the storage environment through ice that builds up on the coils and through air exchange with the outside. Dry wooden storage containers also absorb water during the initial storage period.

### ● Coil Temperature

The minimum humidity level in the storeroom is determined by the temperature difference between the evaporator inlet and outlet. This temperature "split" as it is sometimes called, is approximately 1/2 the temperature difference (TD) between the refrigerant and the storeroom atmosphere. Table 3 shows the effect of this temperature split upon minimum relative humidity. A temperature split of not more than 2° or 3° should be allowed to maintain a minimum relative humidity of 90%. This would require a suction temperature approximately 4° to 5°F colder than the storage temperature in most cases. Where very high relative humidities are desired (over 95%), the suction temperature should be maintained only 2°F below room temperature; this will result in a temperature drop of the air stream on the order of 1°F.

**Table 3.** Minimum Relative Humidity Levels<sup>1</sup> Developed at Various Storage and Evaporator Discharge Temperatures

Temperature Drop <sup>2</sup> Across Evaporator, °F	Storeroom Temperature, °F		
	32°	35°	38°
-1°	95.8	96.1	96.1
-2°	91.2	92.3	92.4
-3°	87.1	88.7	88.8
-4°	83.0	84.7	85.3
-5°	79.4	80.9	82.0
-10°	62.7	64.1	65.3
-15°	49.3	50.5	49.4

<sup>1</sup>Calculated from Psychrometric Tables.

<sup>2</sup>Actual airstream temperature drop between inlet and outlet. The coil TD will be approximately twice this value.

High humidity storage minimizes weight loss. Since the evaporator TD determines the humidity level, both the TD and cooling capacity of the evaporator must be specified in the cold room design. Cooling capacity of a system increases when the TD is increased. Doubling the TD approximately doubles the cooling capacity, but unacceptably low levels of relative humidity result. There is also a danger of freezing the product near the evaporator discharge, if the discharge temperature is below the commodity freezing point. In addition to the freezing danger and low relative humidity problem, coils operated at low suction pressures frost rapidly and must be frequently defrosted to maintain good air flow over the coil and throughout the room.

To provide high humidity long term storage, set the Evaporator Pressure Regulator (EPR) correctly and close the bypass valve after the produce has cooled. A system operated at low suction pressure without the EPR or with incorrect evaporator pressure settings will have low humidity and freezing problems, even if the coil is properly sized for high humidity storage.

Table 4 lists the optimum levels of temperature and humidity for storage of selected horticultural crops. In some instances the variety, maturity, and intended use of the product will require variations in the storage environment.

**Table 4.** Recommended Storage Environment for Selected Horticultural Crops

Commodity	Temperature °F	Percent Relative Humidity
Apples	32-38 <sup>2</sup>	95
Grapes	30-32 <sup>3</sup>	95
Pears	30-32 <sup>3</sup>	95
Cabbage	32 <sup>4</sup>	95+
Carrots	32	98+
Celery	32 <sup>4</sup>	95
Sweet Corn	32	95
Lettuce	32	95+
Onions (dry)	32	65-70
Potatoes (early crop)	36 <sup>5</sup>	90
Potatoes (chip stock)	50-55 <sup>3</sup>	95
Potatoes (table stock)	45 <sup>3</sup>	95
Potatoes (seed)	37 <sup>3</sup>	90
Squash & Pumpkins	50-55	60-75
Tomatoes	45-70 <sup>5</sup>	85-90

<sup>1</sup>Detailed storage information for other crops is published in USDA Handbook 66 available from the U.S. Government Printing Office, Washington, D.C. 20402.

<sup>2</sup>See Information Bulletin No. 191 for detail concerning variety and CA storage requirements.

<sup>3</sup>Temperature highly dependent upon duration of storage and variety.

<sup>4</sup>See reference by Furry, et al. regarding CA storage requirements.

<sup>5</sup>Short term storage depending upon maturity.

### ● Coil Type

Present-day refrigerated storages use both "wet" and "dry" coils. The older forced convection cooling systems use a continuous spray defrost of brine for 32°F rooms or water for 36+°F rooms to prevent frosting of the evaporator coil. Evaporator coils of this type are in constant contact with the brine or water spray — hence the term "wet" coils. By comparison, virtually all new installations are defrosted intermittently with warm water, hot refrigerant, or electric heaters. Defrosting is done two or three times a day; the rest of the time the coil is directly in contact with the room atmosphere and, hence, is "dry."

Dry coil evaporators offer several advantages over brine and water spray units. The dry coils are ceiling mounted; they take up less storage volume and air distribution is achieved without expensive duct work. The salt corrosion encountered with brine spray is eliminated, and less energy is required because the brine pump is not needed.

Some storage operators speculate that the relative humidity levels may be lower in the dry coil rooms than in wet coil installations. This is not the case because room humidity is determined by the evaporator coil temperature and not by the presence of water or brine on the coil surface. Observations summarized in Table 5 and Figure 7 have shown that both water spray (36°-38°F room temperature) and brine spray (32°F room temperature) defrost evaporators provided less humidity than dry coil units at the same storage temperatures. The range of relative humidity values in Figure 7 vary from 79% to 96% for the wet coils and from 88% to 98% for the dry coils. Table 5 shows the dry coil rooms averaged 93% RH compared with 89% for the wet coil rooms.

**Table 5.** Average Relative Humidity Observed in 40 Sealed CA Rooms, 1979-81

Type of Evaporator Coil	CA Room Temp.		Average
	37°	32°	
Wet	88a	91b	89y
Dry	94c	92bc	93z
Average	91q	92q	

Means and averages followed by different letters are significantly different from each other.

**Figure 7.** Relative Humidity Levels Observed in 40 Sealed CA Rooms

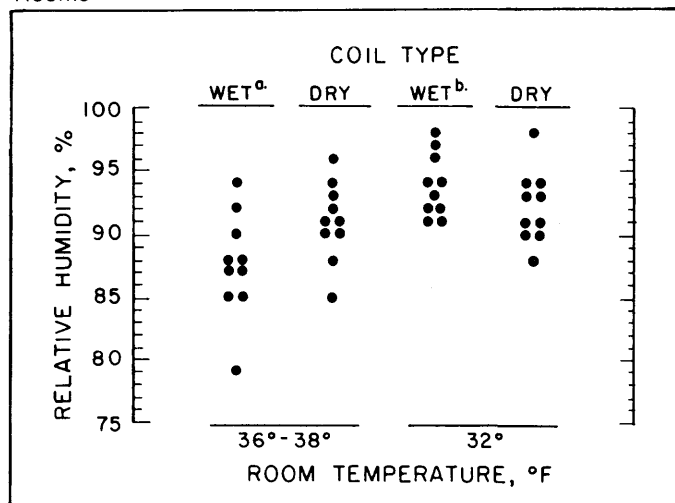

a. Continuous Water Spray  
b. Continuous Brine Spray

## Load Calculations

The cooling load and refrigeration hardware required for a particular application are determined by several factors. These include field heat removal, respiration heat from the product, and heat gained from outside the cold room. Accurate determination of the cooling load is necessary for selection of equipment having adequate capacity to

efficiently cool and maintain the proper temperature and humidity levels in the storeroom.

### • Field Heat

Field heat represents the cooling necessary to reduce the product from harvest temperature down to the safe storage level. The quantity of product harvested each day, the harvest temperature, and the rate of cooling all affect the field heat load. The field-heat load is computed from

$$Q_1 = MC\Delta T$$

where:  $Q_1$  = field heat removal rate, Btu/24 hrs

$M$  = mass of product cooled per 24 hours, lbs,

$C$  = specific heat of product, Btu/lb°F,

$\Delta T$  = temperature drop of product in 24 hours, °F

The value of  $C$  for many products is included in Table 6.

### • Heat of Respiration

The heat of respiration is the energy released by the product as it respire. Respiration heat production decreases during cool-down and stabilizes after the storage temperature is reached. Respiration data for selected crops is given in Table 6.

The respiration load is found from

$$Q_2 = MK$$

where:  $Q_2$  = respiration heat load, Btu/24 hr,

$M$  = mass of product cooled per 24 hours, tons,

$K$  = rate of respiratory heat production, Btu/24 hr ton.

The value of  $K$  is found by averaging the values given in Table 6 at the average product temperature during the 24 hour period.

### • Conductive Heat Gain

Heat is gained and lost through the building floor, walls, and ceiling by conduction. Conduction gain (loss) depends upon the temperature differences between the inside and outside of the cold room and the insulating value of the floor, walls and ceiling. Heat is gained when the room is colder than the surroundings, and heat is lost during the winter when outside air is colder than the refrigerated room. Conductive heat gain or loss is computed from

$$Q_3 = 24 A(T_o - T_i)/R$$

where:  $Q_3$  = conductive heat gain (loss), Btu/24hr,

$A$  = area of floor, wall or ceiling, sq ft,

$T_o$  = outside temperature, °F,

$T_i$  = inside temperature, °F,

$R$  = R value of respective component, {hr sq ft°F}/Btu.

**Table 6. Heat of Respiration and Specific Heat of Fresh Fruits and Vegetables when Stored at Various Temperatures<sup>1</sup>**

Commodity	Heat of Respiration, Btu per ton per day at indicated temperature <sup>2</sup>					Specific Heat Btu/lb°F
	32° F	40°-41° F	59°-60° F	68°-70° F	77°-80° F	
Apples	500- 900	1,100- 1,600	3,000- 6,800	3,700- 7,700	--	.87
Asparagus	6,200-13,200	13,000-23,100	25,500-51,500	38,300-59,200	81,800-104,700	.94
Beans, snap	5,500- 9,000	9,200-11,400	32,100-44,100	45,400-53,000	--	.91
Beets, topped	2,700	4,100	7,200	--	--	.90
Berries:						
Blackberries	3,900- 4,300	6,900- 9,000	--	34,300-42,000	--	.88
Blueberries	500- 2,300	2,000- 2,700	7,500-13,600	11,400-19,200	17,200- 27,300	.86
Raspberries	3,900- 5,500	6,800- 8,500	18,100-22,300	--	--	.85
Strawberries	2,700- 3,900	3,600- 7,300	15,600-20,300	22,500-43,100	37,200- 46,400	.92
Broccoli, sprouting	4,100- 4,700	7,600-35,200	38,200-74,800	61,200-75,000	123,200-193,600	.92
Brussels sprouts	2,200- 6,600	4,800-10,600	14,100-29,900	18,900-37,800	--	.88
Cabbage	1,000- 1,400	1,700- 2,700	4,100- 5,700	6,100-10,800	10,700- 14,000	.94
Carrots	2,100- 4,500	2,800- 5,800	5,700-11,800	10,100-20,900	--	.91
Cauliflower, trimmed	3,600- 4,200	4,200- 4,800	9,400-10,800	16,500-18,900	18,500-30,800	.93
Celery	1,600	2,400	8,200	14,200	--	.95
Cherries, sour	1,300- 2,900	2,800- 2,900	6,000-11,000	8,600-11,000	11,700-15,600	.87
Cherries, sweet	900- 1,200	2,100- 3,100	5,500- 9,900	6,200- 7,000	--	.84
Corn, sweet, with husks	6,600-11,300	9,400-18,300	33,300-38,400	59,000-68,400	62,000-95,800	.79
Cucumbers	--	--	3,300- 7,300	3,100-10,600	4,200-12,100	.97
Garlic	900- 3,100	2,000- 7,300	3,100- 6,400	2,900- 5,500	--	.69
Grapes, American	600	1,200	3,500	7,200	8,500	.86
Grapes, Vinifera	300- 500	700-1,300	2,200- 2,600	--	5,500- 6,600	.85
Leeks	2,100- 3,700	4,300-6,400	18,200-25,700	--	23,600-26,100	.88
Lettuce, head	1,300- 3,700	2,900- 4,400	7,000- 9,900	11,200- 13,200	16,100-20,100	.96
Melons:						
Cantaloupes	1,100- 1,300	1,900- 2,200	7,400- 8,500	9,800- 14,200	13,700-15,700	.94
Watermelons	--	700- 900	--	3,800- 5,500	--	.94
Mushrooms	6,200- 9,600	15,600	--	58,000- 69,600	--	.93
Onions, dry	600- 700	700- 800	2,300- 2,500	3,100- 4,200	6,000- 6,400	.90
Onions, green	2,300- 4,900	3,800-15,000	14,500-21,400	17,300- 34,300	21,500-46,100	.91
Parsnips	2,600- 3,400	1,900- 3,900	7,100- 9,400	--	--	.83
Peaches	900- 1,400	1,400- 2,000	7,300- 9,300	13,000- 22,500	17,900-26,800	.91
Pears, Bartlett	700- 1,500	1,100- 2,200	3,300-13,200	6,600- 15,400	--	.86
Peas, green, shelled	10,400-16,600	17,400-21,400	--	76,700-122,400	--	.79
Peppers, sweet	--	1,100- 4,700	4,400-12,600	5,000- 14,300	7,900-16,300	.94
Plums	400- 700	900- 2,000	2,600- 2,800	3,700- 5,700	6,200-15,600	.89
Potatoes, immature	--	2,600	2,900- 6,800	4,000- 9,900	--	.85
Potatoes, mature	--	600- 1,900	1,300- 2,600	1,800- 3,500	--	.82
Spinach	4,200- 4,900	7,600-12,700	29,500-49,200	37,900- 63,200	--	.94
Squash, butternut	--	--	--	--	14,500-26,800	.88
Squash, yellow straightneck	2,600- 2,800	3,100- 4,100	16,500-20,000	18,700- 21,400	--	.95
Tomatoes, ripening	--	1,300	5,300- 6,400	5,300- 9,700	6,600-11,500	.95

<sup>1</sup>Summarized from USDA Handbook 66.

<sup>2</sup>Values may be reduced as much as 50% during CA storage.

The individual ceiling, wall, and floor heat gain values are computed separately and then totaled for the entire building. For design, use the maximum expected outside air temperature to determine the temperature difference. This is usually the warmest daytime temperature expected during the loading period. Find the worst case winter condition by using the expected minimum daily temperature during midwinter. Evaluation of heat loss during winter storage will determine if supplemental heat will be needed to prevent freezing or to maintain desired storage conditions.

The temperature above ceilings that are under flat roofs may be 10°F greater than for the side walls because of solar effects. Walls adjacent to other operating cold rooms at the same temperature have no temperature difference. Base the temperature values for exterior walls on the selected maximum or minimum ambient conditions.

Heat gain or loss through the floor is difficult to calculate. Deep soil temperatures are usually assumed to be equal to well water temperature for a particular location. However, the unknown factors of soil moisture content and soil insulation value under the storage make the calculations uncertain. Base calculations upon soil temperatures of 50° to 60°F existing at the base of the subfloor to give a conservative (high) value for the cooling load. These values are accurate for the first few days of operation, after the storage has been shut down during the summer.

If the storage has operated continuously, the heat gain through the floor will be less because much of the underlying earth has already been cooled. Data from the West Coast and recent observations in New York indicate that the heat gain through the floor of a cold storage with perimeter insulation decreases from approximately 10 to 15 Btu/hr sq ft during the start of cooling to 2 to 4 Btu/hr

sq ft in the winter. Total floor insulation would cut this heat gain in half and help reduce the total conductive cooling load at pull down.

## ● Convective Heat Gain

Heat also transfers by the mixing of outside air with the cold inside environment. These convection losses (heat gains) are high during summertime loading and minimal when the room is closed. Convective heat gain can be approximated by

$$Q_4 = (ho-hi)VN/13.5$$

where:  $Q_4$  = convective heat gain

$ho$  = enthalpy (heat content) of outside air, Btu/lb,

$hi$  = enthalpy (heat content) of inside air, Btu/lb,

$V$  = volume of empty storeroom, cu ft,

$N$  = number of air changes per 24 hours,

13.5 = an average value for the specific volume of outside air, cu ft/lb.

The values of  $ho$  and  $hi$  for different air temperatures are given in Appendix Table 9. Representative values for  $N$  as a function of  $V$  are given in Appendix Table 10. During loading,  $N$  may be as large as 2 to 4, and zero under CA conditions. Note that if cold rooms are open for long periods in the winter, heat loss may increase the danger of freezing the product in storage.

## ● Equipment Load

Equipment operating in the room also generates a heat load. Lift trucks, lights, motors, pumps, scrubbers, and so forth, generate heat that must be removed by the refrigeration system. Permanent equipment located in the cold room can be accounted for in the load calculation. Each kilowatt hour of electricity used in the storeroom will add 3,430 Btu to the cooling load. Every horsepower of electric motor capacity used in the room adds the equivalent of 2,545 Btu to the cooling load for every hour it is used. Heat from motor inefficiency, other equipment, lift trucks, scrubbers, burners, and people in the room is usually accounted for in a service factor that is added to the total computed load.

The equipment load is found from

$$Q_5 = (kW \times 3430) tl + (Hp \times 2545) tm$$

where:  $Q_5$  = heat produced by equipment, Btu/24 hr,

$kW$  = kilowatt total for electric lights,

$Hp$  = horsepower total for motors,

$tl, tm$  = total hours of operation per day for lights and motors, respectively.

## ● Total Cooling Load

Add the individual heat gains computed as shown to find the total heat gain for a cold storage. Normally a service factor of 10% to 20% is then added to the total cooling load. In addition to miscellaneous equipment, this accounts for brief periods of unusually hot weather, loading rates that temporarily exceed those anticipated, or other unusual conditions of short duration.

Finally consider the cooling time lost during defrost. Brine and water spray evaporators do not have to be shut down for defrosting. This advantage is offset by the cost of pumping water or brine and the cost of removing the heat added by the recirculated liquid. Dry coil evaporators must be shut down for defrost. Four defrost periods of 30 to 60 minutes, each, per 24 hours may be needed during loading. This defrost cycle reduces the operating time from 24 hours per day to 22 or 20 hours per day. To compensate for this defrost time, increase the cooling capacity of the coil by a factor of 24/22 or 24/20. A refrigeration contractor, familiar with defrost requirements of specific types of hardware can best determine this defrost factor.

Thus, the total installed capacity of the refrigeration system is

$$Capacity = Qt \times SF \times DF$$

where  $Qt$  = calculated total heat gain, Btu/24 hr,

$SF$  = service factor, typically 1.1 to 1.2,

$DF$  = defrost factor, typically 1.1 to 1.2.

Cooling capacity is measured as "tons" of refrigeration. This unit is based upon the cooling obtained from melting 2,000 pounds of ice in 24 hours. One ton of refrigeration is equal to 288,000 Btu/24 hr or 12,000 Btu/hr. The capacity required for a cold storage can be specified in either tons of refrigeration or Btu/24 hr.

The actual load may be calculated in several ways:

- Each factor can be computed manually using the equations presented. An example of this technique is given in Appendix 1.
- Equations (1) through (7) can be solved with programmable calculators or personal computers.
- Private consultants and refrigeration contractors can be hired to size refrigeration systems. Hardware manufacturers have developed computational software and load calculation worksheets for this purpose.
- Tabular data may be applicable to some situations. This method is generally used for small coolers where refrigeration capacity is based on empty storage volume although it will not indicate the seasonal variations in equipment use. Load calculations should be

performed to determine the cooling demand at different times during the storage season in large storerooms.

Figure 8 shows an example of the seasonal refrigeration requirement for a 15,000 bushel apple storeroom. If this room was loaded in 10 days (1,500 bu/day), it would require a maximum capacity of 13.4 tons of refrigeration. If the room was loaded in 8 days (1,875 bu/day), the system would need 16.2 tons of cooling capacity. After field heat removal, respiration requires only 0.85 ton of cooling. During the cold winter period less than 1.5 tons is needed to keep the entire 15,000 bushels at 32°.

Table 7 lists refrigeration loads for several vegetable commodities with the effects of commodity type, maturity, and harvest date upon the maximum refrigeration capacity requirement. Note the substantial influence of field heat upon the total cooling load.

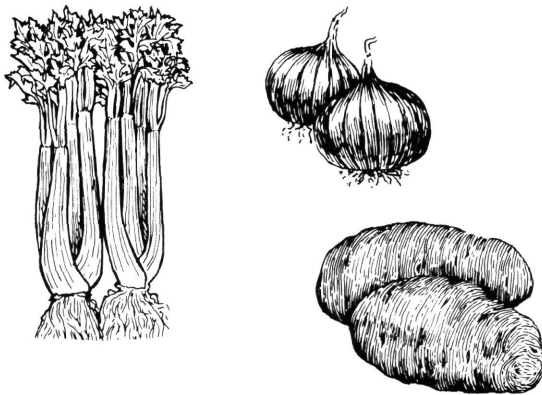

Figure 8. Refrigeration Capacity Needed to Cool and Maintain 15,000 Bushels of Apples

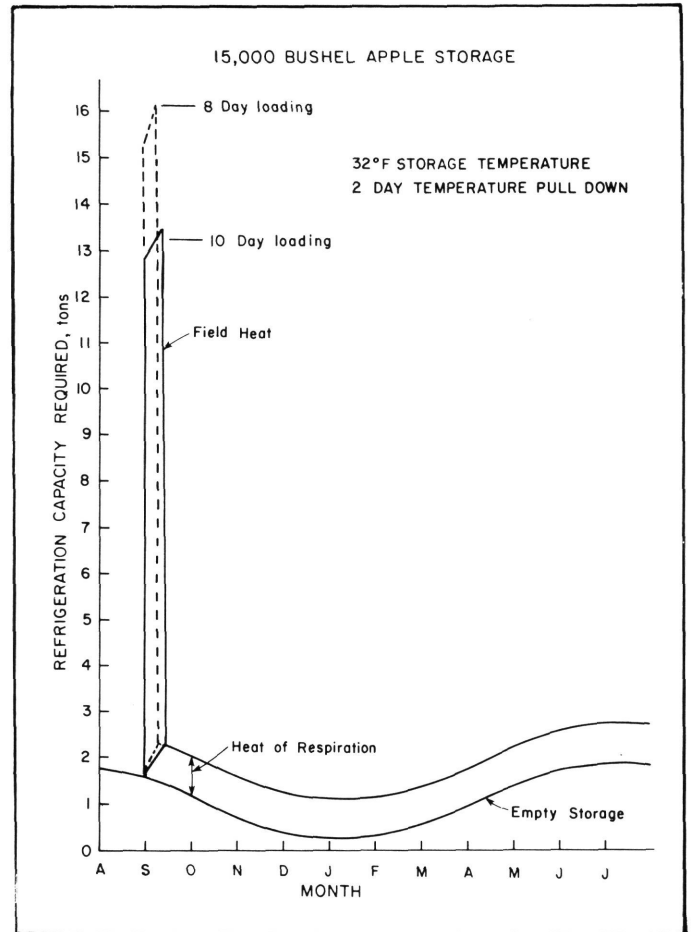

Table 7. Example of Load Calculations for Several Horticultural Crops and Harvest Conditions

Harvest and Storage Conditions <sup>1</sup>	Early Potatoes	Late Potatoes	Early Cabbage	Late Cabbage	Late Onions
Harvest Date	August 1	September 15	September 1	November 1	September 1
Harvest Temp.	84°F	75°F	78°F	56°F	78°F
Storage Temp.	45°F	45°F	32°F	32°F	32°F
Storage Capacity	10,000 cwt	10,000 cwt	500 ton	500 ton	10,000 cwt
Harvest Rate	1,000 cwt/day	1,000 cwt/day	50 ton/day	50 ton/day	1,000 cwt/day
	Tons of Refrigeration Required <sup>2</sup>				
Field Heat Removal	12.4	9.0	15.8	2.7	15.1
Respiration	6.0	2.6	3.2	2.3	1.6
Building Losses <sup>3</sup>	5.7	3.7	7.0	3.0	5.5
Total Required	24.1 tons	15.3 tons	26.0 tons	8.0 tons	22.2 tons

<sup>1</sup>Based upon New York State weather & harvest situations

<sup>2</sup>Capacity in tons of refrigeration (1 ton = 12,000 Btu/hr)

<sup>3</sup>Including Heat Gain from lights, equipment and air infiltration



## ● Compressors for Small Coolers

Walk-in coolers and cold rooms such as those used at roadside markets usually have refrigeration capacities specified in terms of the horsepower ratings of the compressor. Table 8 lists the recommended refrigeration capacities for small coolers based on average use and summer conditions as specified by prefabricated cooler manufacturers. The humidity specifications for these small coolers should be the same as for large produce coolers.

If coolers of this type are used to cool produce in cartons or to partially cool bulk products, plan for additional cooling capacity and air movement. Produce in cartons and bags stacked on pallets require special equipment for rapid cooling.

**Table 8.** Compressor Capacity Recommended for Small Coolers<sup>1</sup>

Dimensions ft.	Volume cubic feet	Cooling Load Btu/hr.	Compressor Size Hp <sup>2</sup>
6x6x9	324	2,800	0.50
6x12x9	648	4,500	0.75
8x8x9	576	4,100	0.75
8x12x9	864	5,500	0.75
8x16x9	1152	7,100	1.00
10x10x9	900	5,600	0.75
10x15x9	1350	7,900	1.50
12x12x9	1296	7,700	1.00
12x20x9	2160	9,800	1.50
20x20x9	3600	15,800	3.00

<sup>1</sup>Based on Prefabricated cooler data with R-30 box insulation, 35°F inside and 90°F outside temperature.

<sup>2</sup>Nearest fractional horsepower matched to cooling load times a service factor of 1.5

## Rate of Cooling

A system that has both adequate refrigeration capacity and an efficient air distribution system removes field heat most effectively. Base the refrigeration capacity on the actual rate of loading and the cooling time desired. An undersized or overloaded refrigeration system will neither cool rapidly nor hold the desired storage temperature levels during loading. The cooling air must be delivered in sufficient quantity and at proper velocity to provide effective cooling throughout the storage volume. Better air distribution is obtained from several small evaporators equally spaced along one wall than with a single large unit of equivalent capacity located in the center of the wall.

## ● Loading and Stacking

Room loading and stacking patterns have a major effect upon air distribution and the rate of cooling. Ideally, the warm product should be spread out in the storage with the warmest commodity exposed to the coldest portion of the air stream. This ideal may not always be possible because of product lots and the configuration of the room, but try to distribute warm products in the room during loading. It may be possible to use several rooms for initial cooling and to restack the primary storage room each morning before new products arrive. Stacking the first hot product directly underneath the evaporator helps ensure that the warmest product is in contact with the coldest air as the evaporator discharge stream is moved over the top and back through the stacks of newly loaded produce.

Always stack pallet bins so the skids run the same direction as the evaporator discharge as shown in Figures 9 and 10. Properly oriented bins form air-distribution channels for faster cooling from both the top and bottom bin surfaces. Use identical pallet bins in each row to ensure that the runner openings are continuous from the

**Figure 9.** Stacking Pattern for Maximum Cooling Efficiency in Room with Evaporators Located at the End

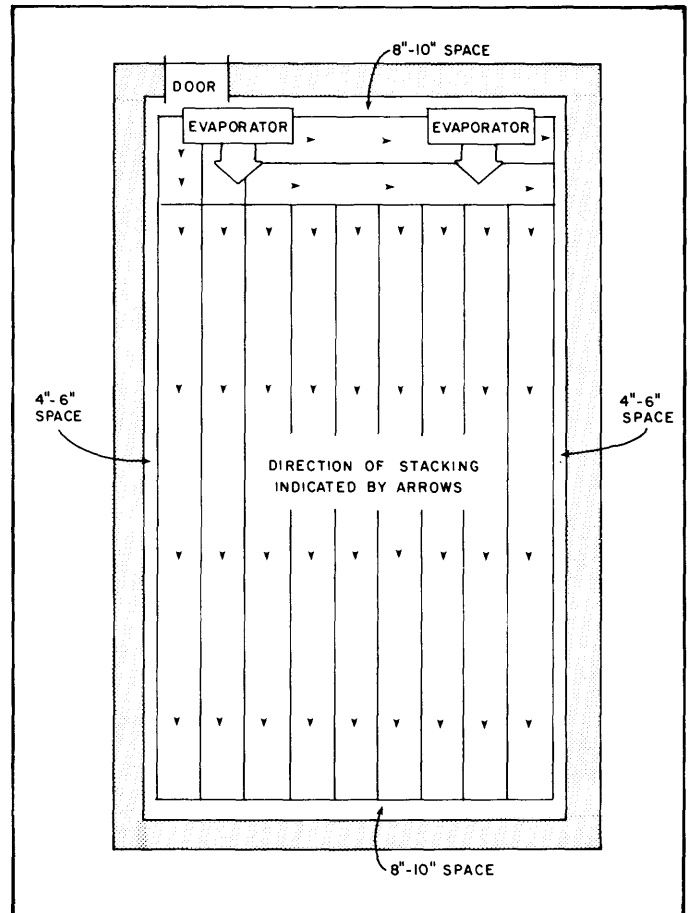

**Figure 10.** Stacking Pattern for Maximum Cooling Efficiency in Room with Evaporators Located at the Side

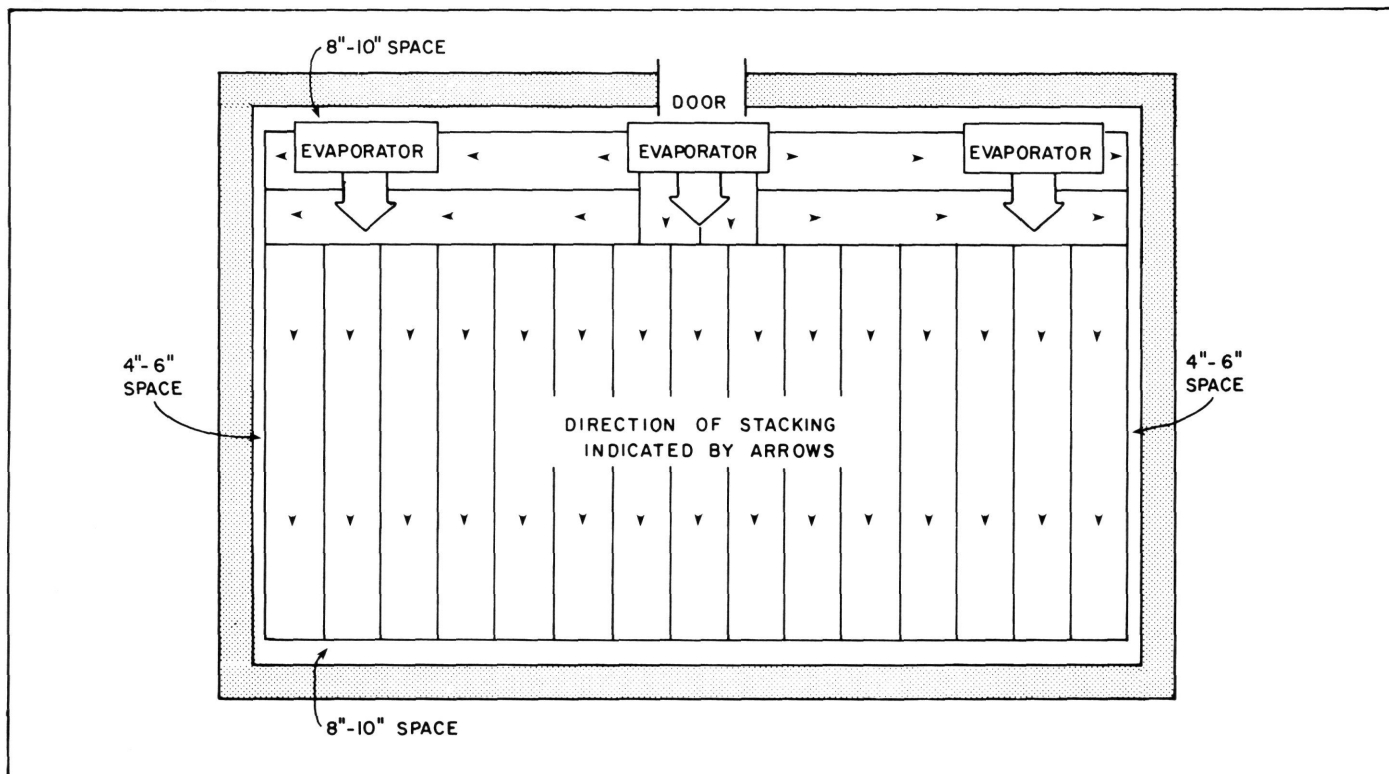

front to the back of the room. If only one pallet bin within the row is a different height, it will partially block air flow through most of the pallet runner openings. Bins in the last one or two rows near the doorway can be turned 90° to the air flow to load the last produce in the room.

Bin stacking is easily managed if the bin row location is painted on the floor. For new storages, plan the stacking patterns relative to the refrigeration system before construction begins. Good planning will ensure optimum use of floor space and refrigeration capacity during cooling.

Leave at least 8" to 10" between the pallet bin stack and the wall downstream from the evaporator. This space allows the cooling air to pass down behind the stacks on the far wall, circulate uniformly back through the produce, and return to the evaporator. Leave a 4" to 6" space between the outside bins and the side walls for air movement. Sometimes it may be desirable to block this side space near the back of a tightly stacked room so that all cooling air is returned through the pallet stacks. If spaces (4" to 6") are left between adjacent rows of bin stacks, do not block the side wall spaces. A curb around the perimeter of the storeroom guarantees this bin to wall spacing and protects the wall insulation and gas seal from damage.

Dry coil evaporators with high capacity propeller fans will discharge air 50' to 70', if the area above the bin

stacks is kept clear. Nonuniform bin heights, lime pallets on top of the stacks, structural protrusions, and low ceiling clearance all reduce the efficiency and throw of fans. These conditions short circuit air back to the evaporator instead of allowing it to pass through the stacked produce. Place evaporators where air channels in the direction of the structural components or runs from a high ceiling at the center towards the low point near the eaves of a pitched roof ceiling. Also stack the bins from the outside wall to the center of the building in this case. Position doors to facilitate loading and stacking for the best air movement. It may be necessary to alter stacking patterns in rooms where old floor mounted blowers and distribution duct systems have been replaced with ceiling mounted blowers.

### ● Pallet Bin Construction

Pallet bins should have a minimum of 8% to 11% of the bottom surface area open for air circulation. Apples in tightly stacked bins with bottom openings typically take 15 hours to half cool. This cooling rate is comparable with that obtained in palletized bushel boxes. Pallet bins with 6% and 8% open areas in the floor and sides, respectively, half cool in about 10 hours. Three half cooling periods are needed to remove 87% of the field heat.

## ● Temperature Sensors

Thermometers inside the storage indicate the temperature of the air and the product. Usually plan to place two thermometers inside each CA room, if a remote temperature sensing system is not used. Place one thermometer inside the access hatch at the CA door, and another behind the observation window at the upper level. Calibrate thermometers and remote temperature probes in a stirred 32°F ice water bath to determine the accuracy of each sensor. Mark the correction factor on every probe and thermometer with a tag or tape with the statement, "Add (or subtract) 00 degrees to the reading."

Remote sensors allow the storage operator to monitor temperatures at locations where it would be impossible to read or locate a thermometer. It is also possible to monitor the temperature profiles in a sealed CA room with such a system. Place probes in the following locations:

- Evaporator inlet
- Evaporator discharge near the coil
- Near the product located immediately downstream from the evaporator
- On the ceiling near the center of the room
- All outside walls near the floor
- At the thermostat sensor
- Additional room and product locations as desired

The temperature drop across the evaporator is an indication of the rate of heat and moisture removal by the refrigeration system. This temperature difference is large during pull down, but should be kept small (2°–3°F) during storage to maintain a high relative humidity. Check the discharge and downstream temperatures to be certain that no product is in danger of being injured or frozen. Especially check temperatures near outside walls during very cold winter or very hot summer conditions.

Monitor the sensitivity and set point accuracy of nonindicating mechanical thermostats with a temperature sensor near the thermostat bulb. Other probes can be located as needed to determine cooling rates and long-term storage temperatures of the product.

Reducing air handling equipment operation during storage can cut electrical costs substantially; but install additional probes to indicate storage temperatures and to help determine how long air circulating fans can be turned off. The internal product temperature may also be of interest; but because internal temperatures change slowly, several hours will be required for internal product temperatures to reflect unacceptable high or low storage temperatures.

Check temperature probes near the ceiling to be sure that respiration heat and heat from the outside has not

caused an unacceptable rise in storage air temperatures. Similarly check the temperature around the outside walls near the floor to be sure there is no danger of freezing.

## Operating Procedures

---

The size and complexity of a cold storage partially determine seasonal operating procedures. Individual low-horsepower sealed compressors, which require a minimum of maintenance will serve small plants and walk-in coolers. Large multicompressor storages may require a refrigeration contractor or full time plant mechanic. The following guide is for those who operate their own refrigeration systems. If complex problems arise, refer then to competent refrigeration service personnel.

### ● Refrigeration Plant Start-up

When the refrigeration system is operated on a seasonal basis, check the following items before start-up.

- Check and clean condensers. Use high pressure water to clean dirt and debris from condenser coil surfaces and air passages. Clean and repair all nozzles of water cooled condensers.
- Check condenser fans. Make sure all fans operate and that fan belts and motors are in proper repair. Grease all relubricable bearings.
- Check evaporators. Clean and replace nozzles on brine or water spray units. Check and clean water defrost systems on dry-coil units. Make sure all fans and blowers are in good condition. Replace worn belts and grease all relubricable bearings before start-up.
- Visually inspect the entire system. Check areas of probable refrigerant leaks before starting compressors. Pay particular attention to soldered joints, seals, gaskets, valves, and vibrating parts.
- Be certain all motors are dry before start-up. Motors located in compressor rooms at or below grade will accumulate moisture in the motor windings during shutdown. Start-up of a motor with moisture in the windings may seriously reduce motor life or cause permanent damage. Thoroughly dry motors in damp locations before start-up, either with radiant heaters suspended over each unit or with a portable heater. Use caution with portable heaters and keep the heat blast away from any refrigerant vessels, lines, driers, and the like.
- Check oil level in compressors and refill as needed.
- Check and tighten belts on belt driven equipment.
- Start compressor. Monitor oil level and oil pressure during start-up.

- Check refrigerant level. Be certain there is a full charge in the system. Leak test and recharge if needed. Be sure to recheck refrigerant level every time a new room is turned on, another compressor is started, or the water pump on the condenser unit is turned on. The addition of extra load, additional compressor capacity, and improved condenser efficiency will all affect the volume and quantity of charge needed.
- Check evaporator operation. Make certain expansion valves, EPR, bypass valves, all float switches, and pressure modulating controls are operating correctly.
- Check thermostat. Turn rooms on 4 or 5 days before the first produce is loaded. Make sure the thermostat is functional and controlling temperature within desired limits.

## ● Shutting Down

If the cold storage is not needed for a period, it is advisable to pump down the system and store all the refrigerant in the high pressure receiver. Be certain that all refrigerant is pumped out of the evaporator, oil separators, and refrigerant lines before service valves are closed. Hot summer conditions may create extremely high pressures in parts of the valved off system where refrigerant has been trapped. Also do the following:

- Thoroughly wash all brine spray equipment and grease relubricable bearings.
- Remove all crop residue and any remaining water from the storerooms. Empty pallet bins can be stored in empty, ventilated storage rooms.
- Turn off electrical power to compressors, condensers, and evaporator air handlers. Turn off crankcase heaters and other supplemental heat. Heat compressor motors in rooms at or below grade to prevent moisture accumulation in the windings. A single radiant heat lamp for each motor is adequate for this purpose. Control the heat lamps with a timer and operate 4 to 6 hours each day. Wet windings may cause motor failure when the motor is restarted in the fall.
- Remove all debris from the compressor room.
- Order and stock spare parts, seals, valves, pumps, belts, and bearings for the entire refrigeration system before start-up. Schedule and complete all routine plant maintenance and test the system well in advance of loading.

## Refrigerated Bulk Storage

Refrigeration is sometimes used in conjunction with ambient air ventilated storage. Early storage systems relied entirely upon cool natural conditions to preserve crops for short term storage. Large tonnages of cabbage, apples, onions and potatoes are still stored in this manner in the Northeast. Many of the producers of these crops find it beneficial to supplement ambient air cooling with refrigeration in order to extend the storage season and reduce stored product losses. The handling method dictates how the refrigeration and ventilation systems operate. The pallet bin and bulk storage systems are each discussed below.

Storage systems utilizing conventional pallet bins employ the same equipment and operating procedures as were discussed in previous sections on refrigeration. The pallet bin storage refrigeration system operates independently of the mechanical ventilation system, with the evaporator fans providing all of the air movement when refrigeration is being used. Conversely, the ventilation system is used when ambient temperatures permit and under these conditions all air movement and cooling is accomplished with the ventilation hardware.

Products like potatoes and onions are often stored in bulk and with this method the refrigeration and ventilation systems may operate simultaneously. The most common technique for refrigerating a bulk storage is shown in Figure 11. The refrigeration hardware consists of standard ceiling mounted evaporators which operate in conjunction with the high pressure ventilation fan system. Heat is removed from the air on top of the bulk pile and the cool air is moved by the ventilation system through the bulk product. The evaporator discharge should be directed towards the recirculation inlet to be most efficient. Locate the refrigeration control thermostat in the air plenum below the ventilation fan to assure that the product is not being subjected to air which is too cold.

In some bulk potato and onion storage operations the refrigeration coil is incorporated directly into the ventilation system (Figure 12). The evaporator coil used in this situation is designed and installed to permit all of the recirculated air to pass through it with a minimum amount of resistance. Generally, these coils are somewhat thinner (have fewer rows of tubes) and contain a wider fin spacing and tube spacing than conventional ceiling mounted dry coil units. The high humidity requirements for potato storage requires a low TD and therefore a large amount of coil surface is needed. The combination of low air flow resistance and large coil surface requires a coil of specialized design with a large cross sectional area. The size requirements for this coil may necessitate construction of an oversized air plenum to contain it.

**Figure 11. Bulk Storage with Ceiling-Mounted Evaporator Fan**

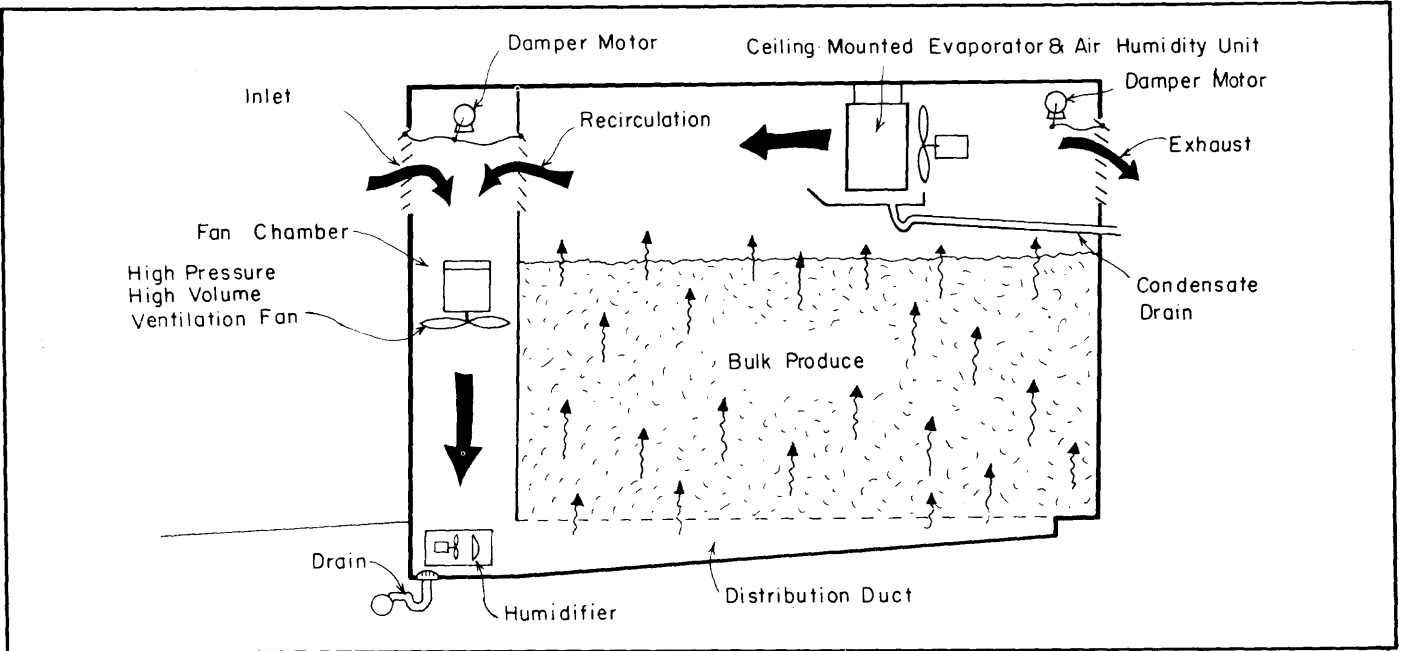

**Figure 12. Bulk Storage with Evaporator Coil located in Air Plenum**

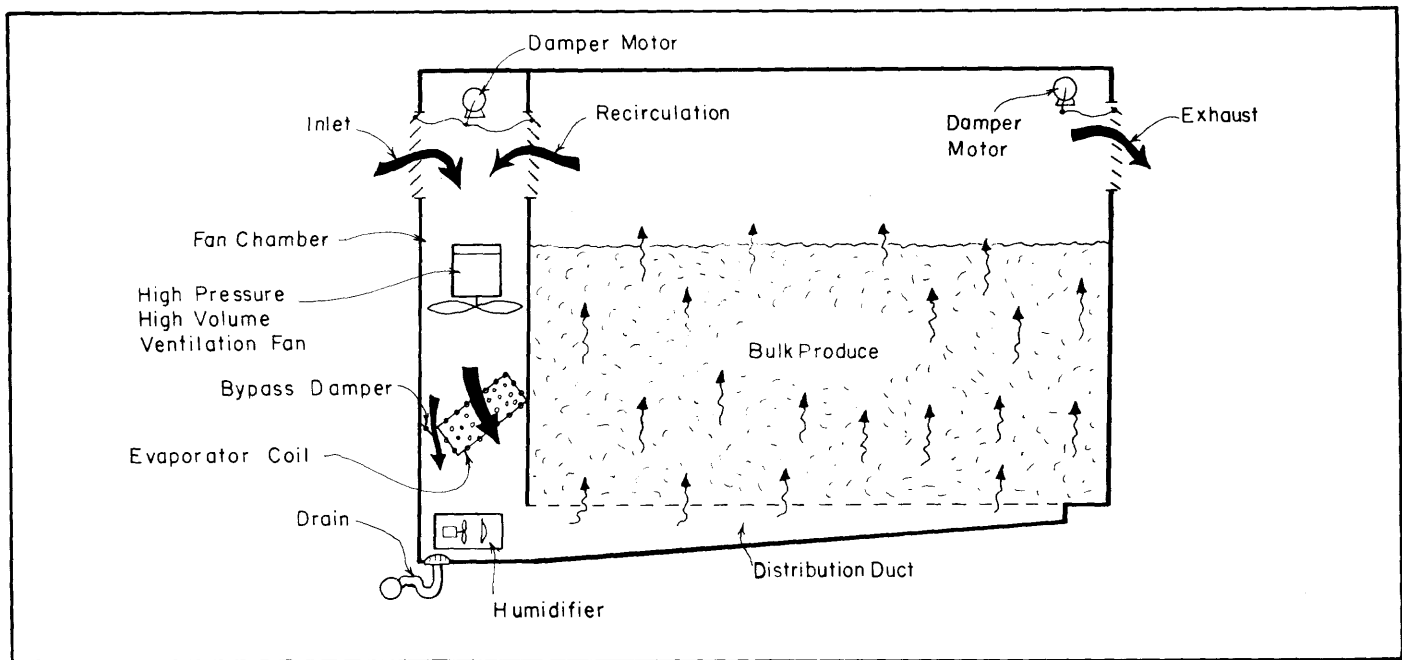

A third type of bulk refrigeration system being introduced into the Northeast is shown in Figure 13 and consists of a self-contained portable refrigeration unit which can be moved from storage to storage as required. Openings are constructed in the air plenum to permit a portion of the recirculated air to pass through the portable refrigeration equipment. A control thermostat is located below the fan discharge to modulate the bypass damper for temperature regulation. The portable system tends to be more expensive to purchase but offers a good economic choice where supplemental refrigeration

is needed only part of the time. For example, the unit may be used to assist in reducing potato temperature after suberization and then moved to another store room as the fall harvest continues. In some cases the storage operator may not know which lots of produce will have the greatest storage potential but will be able to commit the portable refrigeration unit to a particular building or bin as desired in the spring. By so doing it may be possible to utilize one piece of refrigeration equipment on several storerooms throughout the year.

**Figure 13.** Bulk Storage with Portable Refrigeration Unit

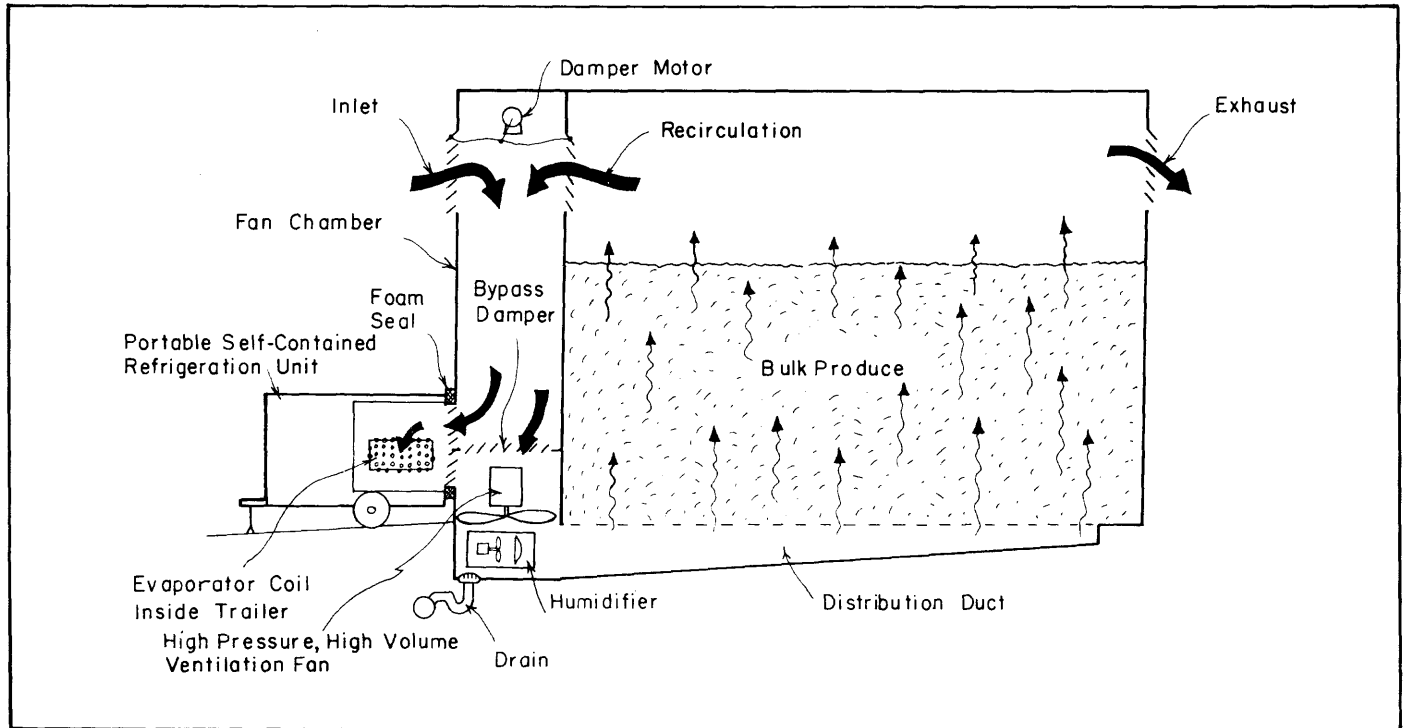

The recommended air exchange and recirculation rates for pallet bin and bulk ventilated storages are given in extension publications dealing with specific commodities of interest.<sup>1</sup> A ventilation capacity of 25 cfm per ton is commonly used and recommended for ambient air storage of vegetables (cabbage, onions, and potatoes). Design bulk systems to deliver this airflow at a static pressure of 1.0 to 1.25 inches of water gauge pressure. If the evaporator coil is installed directly in the air plenum as in Figure 12, the additional air pressure drop through the coil and damper system must be added to the design pressure and the fan capacity should be increased appropriately. The same flow rate (25 cfm/ton) is recommended for ventilated pallet bin storage as well, although

<sup>1</sup>*The Control of Natural-Air Cabbage Storage Environment*, Information Bulletin 137, Cornell University, Ithaca, New York.  
*Storage Recommendations for Northern-Grown Onions*, Information Bulletin 148, Cornell University, Ithaca, New York.

the static pressure requirements of the fan are approximately one tenth of those for the bulk system (i.e. 25 cfm per ton @ 0.15 to 0.25 inches of water gauge).

After the crop temperature is stabilized at the desired level reduce the ventilation rates through intermittent fan operation. Control ventilation fans to operate on demand so as to maintain the desired product temperature. Refrigeration is usually not required during the period when outside air temperatures are below the desired inside storage temperature. As the springtime air temperatures moderate, daytime refrigeration may be used to supplement cool night time ventilation. Late storage will, of course, require total dependence upon the refrigeration system to maintain the desired temperature in the storage. Calculate the capacity of the supplemental refrigeration system from the most severe demand, either fall loading or summer holding conditions.

# Controlled Atmosphere Storage

Controlled atmosphere storage employs reduced temperatures, with reduced oxygen levels and elevated carbon dioxide levels to further suppress metabolic activity in stored products. Commercial applications of CA storage are mainly restricted to the storage of apples, although successful commercial CA cabbage operations are beginning in New York and Canada. Specific CA operating recommendations for many North American apple varieties are found in Cornell Cooperative Extension Information Bulletin 191. Cornell studies recommend 2.5% oxygen and 5.0% CO<sub>2</sub> for long term CA storage of cabbage. Studies of CA storage of celery indicate 3.0% oxygen and less than 1.0% CO<sub>2</sub> are optimum for that crop. The response of other products to CA storage can be found in *Handling, Transportation and Storage of Fruits and Vegetables* by Ryall and Lipton.

Successful CA storage depends on limiting and controlling the concentrations of oxygen and carbon dioxide in the storage environment. Storerooms must be sufficiently airtight to restrict the entry of oxygen from the outside to a rate below that at which product respiration is capable of consuming it. Very careful construction techniques are required to build a cold room that will maintain the desired concentrations of oxygen and CO<sub>2</sub>.

## Construction

### • Sealing Walls and Ceilings

The most common and most reliable material used to seal CA rooms is foamed-in-place polyurethane. Concrete block and precast and tilt-up concrete slabs can be foamed directly with little or no surface preparation. Plywood and chipboard ceilings can be sprayed in a similar manner. Metal surfaces are usually primed to insure adhesion of the foamed-in-place urethane.

A better gas seal is obtained and less foam is needed if the interior surfaces of wood post and steel buildings are lined. Wood roof trusses should have a plywood or chipboard ceiling installed on the lower chord. Do not line the wall and ceiling with rigid board insulation (extruded polystyrene, Styrofoam beadboard, and isocyanurate). Foamed-in-place urethane may distort and loosen these materials upon curing and cause the gas seal to fail during service. Nails and adhesives do not always hold

insulation board materials during repeated pressure changes, so the seal may fail because the insulation board and urethane gradually loosen.

If a cold room is retrofitted for CA, replace all board insulation with foamed-in-place urethane or secure it to the structure with pressure treated 1" x 3" furring strips. Secure the strips with galvanized nails or screws driven through the foam board to the structural backing. If the distance between structural members to which the furring strips are attached exceeds 24", place expanded metal lath over the foam board before the furring strips are attached for additional support.

Leaky CA rooms with sheet metal linings can be upgraded by applying an elastomeric coating. These coatings can usually be applied to the clean surface at a lower cost than urethane insulation, although urethane foam will seal small holes much better. The coatings can also be extended from the wall onto the floor to improve the wall-floor seal. Do not retrofit walls and ceilings if the metal is loose or rusted through, if the insulation behind the metal is wet, or the wood structure has rotted. If any of these conditions exist, completely rebuild the CA room instead.

### • Wall to Floor Joints

The wall-floor joint is the most common failure point in the gas seal. Extreme care is required to prevent separation of the wall and floor seals due to settling of the subfloor. Backfill and mechanically compact the subgrade inside the rooms in 4" layers. Add enough moisture to the backfill material so it is damp but not wet to ensure maximum compaction density. Sand or gravel backfill simplifies the effort. In addition to careful backfilling and compaction, the construction methods shown in Figure 14 ensure that the floor will not settle at the wall-floor joint.

Reinforce both the subfloor and surface floor with the equivalent of 6" x 6" #9 mesh. Specify concrete with a 28-day compressive strength of 4,500 pounds per square inch for both the subfloor and surface slab. Both surface and subsurface slabs should have no expansion joints and should be placed in a single "pour." Extend a continuous surface slab and underlying insulation through the CA doorway.

**Figure 14.** Two Construction Methods Used to Prevent Subfloor Settling and Subsequent Loss of the Wall to Floor Gas Seal

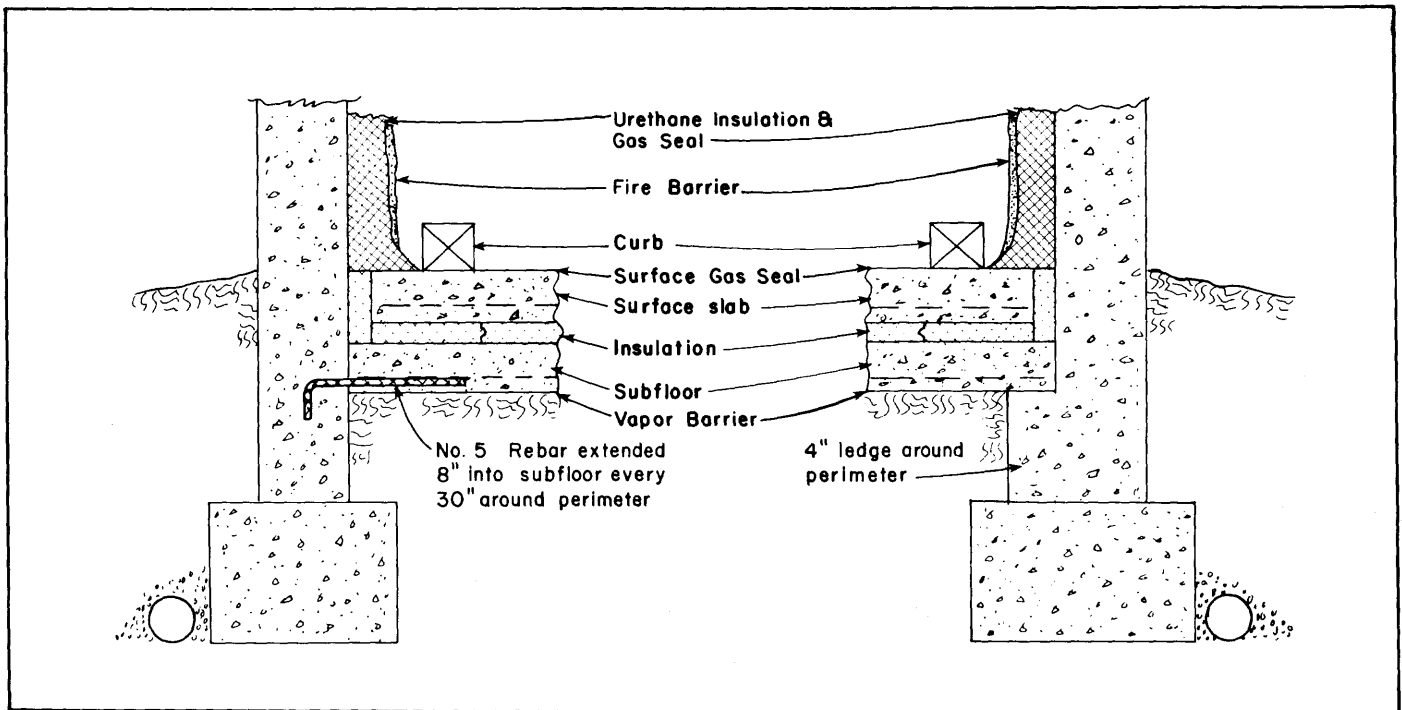

Some contractors install a “shoe” at the wall to floor junction to maintain the gas seal integrity even if the floor settles a small amount. Follow the backfilling and compaction precautions even if a shoe is installed. Figure 16 shows three common types of shoe systems. The first consists of a 28 gauge galvanized iron sheet set in hot (or cold) asphalt and secured to the subfloor with masonry nails. This type of wall to floor seal was common with early CA construction which used asphalt and roofing felt for the subfloor gas seal. This metal shoe and subfloor seal system has been largely replaced by the continuous wall and floor foamed-in-place urethane systems shown in Figure 15.

The second system illustrated in Figure 16 incorporates aluminized mylar sheeting and soft set mastic to create a “flexible” wall to floor seal junction. The mylar is secured to the wall with caulking and “tucked” into a bed of mastic around the perimeter of the room. The entire system is covered with urethane foam. This system can be used with either surface or subsurface floor gas seals.

A neoprene rubber sheet bridges the wall-to-floor joint in the third system shown in Figure 16. The neoprene is glued to the wall and floor before the wall is insulated. A curb protects the sheet.

Install a floor gas seal when the room is first constructed because it is very expensive to install after the room has been built. A common technique incorporates a concrete-surface sealing compound applied directly to the floor

**Figure 15.** Surface Floor Seal Joined to Wall Seal with Polyurethane

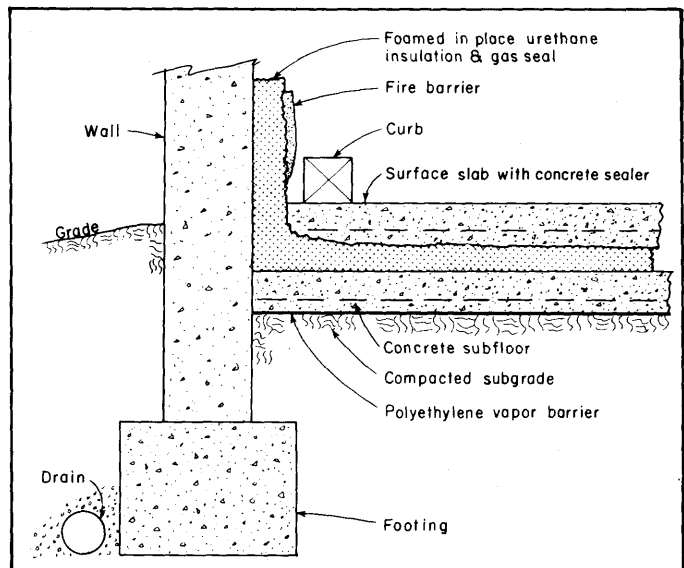

with the foamed-in-place urethane wall insulation sprayed onto it. This method, shown in Figure 15, is widely used in Washington State and in some large western New York CA storage facilities. Board insulation can also be used in the floor (Figure 14), but provide a separate gas seal since this material is not gas tight. It may be possible to retrofit a cold room for CA storage by surface sealing the existing floor, if it is solid and free of cracks. Surface sealing prevents dust in high traffic areas.



**Figure 16.** Three Common Wall to Floor Gas Seal Systems

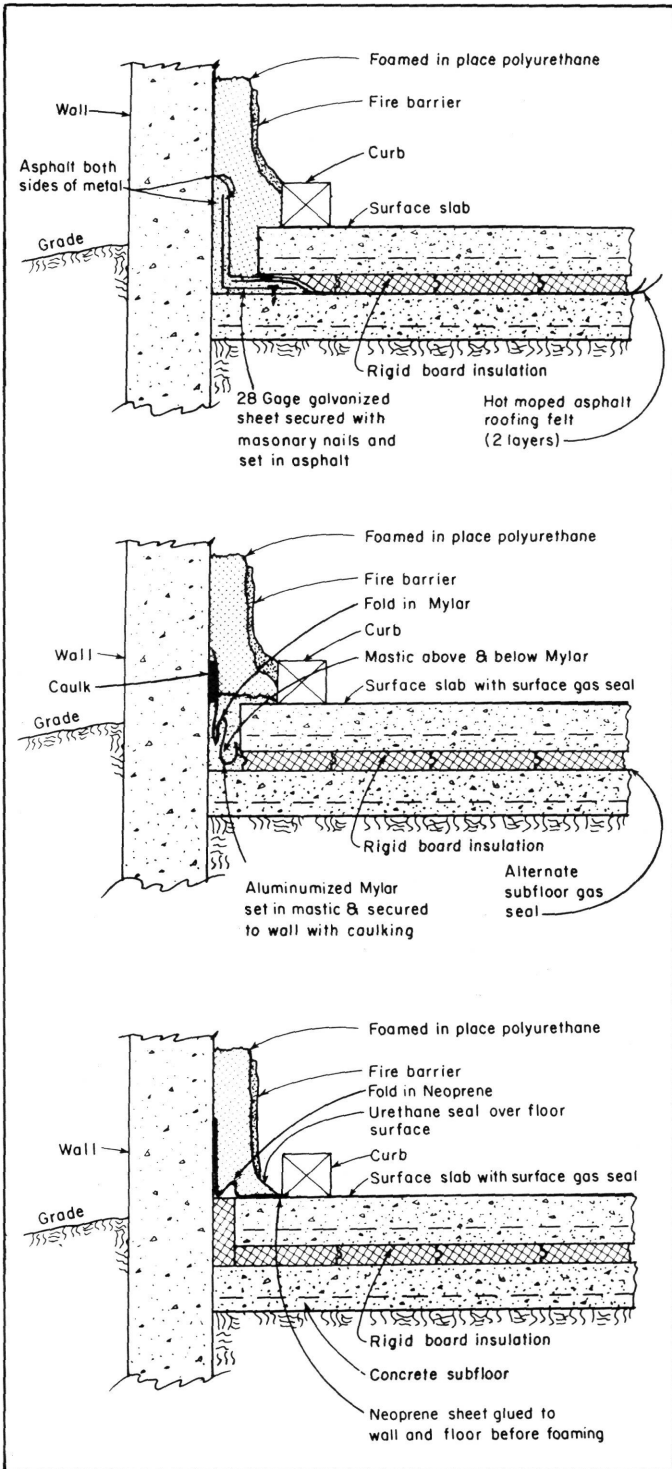

● **CA Doors**

The CA storage room door opening must also be sealed. Commercially manufactured, insulated, sliding gastight doors, which draw down onto rubber gaskets when closed will work. The more common system uses a removable gastight door in conjunction with the permanent sliding, hinged, or overhead cold storage door. The

removable gastight door can be made of metal, wood, or composite materials and may or may not be insulated. Pressure treated plywood should be used on wooden doors.

Paint the surface and edges of the sheets with oil base or epoxy primer before construction, and seal the joints between sheets with butyl or silicone caulk during construction. Wood doors can be framed with pressure treated 2 x 4's and assembled with nonrusting screws or nails. Apply two coats of epoxy paint or an equivalent elastomeric coating to the flat surface of the door after construction. Foam the back side of the door and the framing with urethane insulation.

Similar construction techniques have been used for metal doors. Many older CA installations still use noninsulated doors made of heavy iron plate. Aluminum sheets can also be welded to structural aluminum to create a strong and lightweight airtight door. The back side of these metal doors can also be foam insulated.

Large metal clad and epoxy coated wood CA doors are common in the western United States. These composite doors are framed with wood, stiffened with plywood sheets, and covered with galvanized sheet steel. Joints in the sheet steel cladding are crimped, soldered, or lapped and caulked with silicone. Single oversized sheets of epoxy and fiberglass coated plywood are also used for CA doors. The construction and function of these hand-made, CA doors is very similar to commercial sliding cold storage and CA doors.

Install the removable gastight door from the outside of the CA room. Figures 17, 18, and 19 illustrate several methods of installation. All three systems permit CA door closure without needing someone inside the CA room. The recessed design shown in Figure 18 permits outside

**Figure 17.** Outside Mounted CA Door Secured with Bolts. The "alternate" design permits use of an outside insulated door. Bottom of door is caulked.

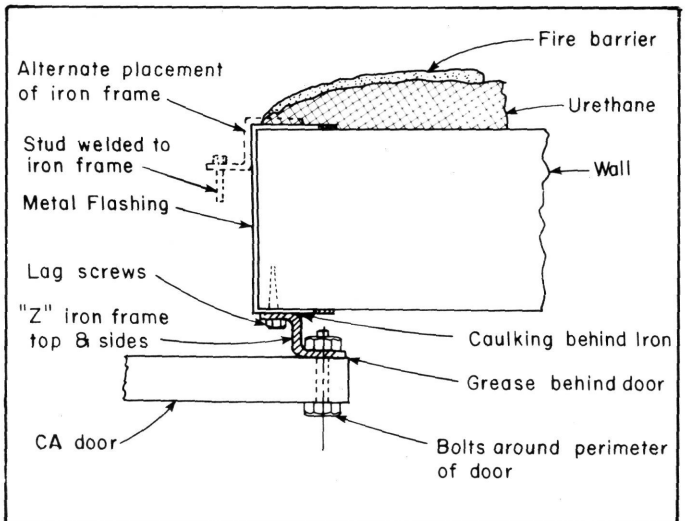

sliding or overhead insulated cold storage doors with the CA doors in place. The Z-iron frame in Figure 17 allows similar operation. Miter and weld the top corners and embed the base of both the Z-iron and channel iron frame (Figure 18) in the concrete surface slab. Complete all welding before applying the wall insulation for fire safety. Structural steel shapes similar to those shown are available from metal building suppliers.

**Figure 18.** Outside Mounted CA Door with Recessed Frame. Bottom of door is caulked.

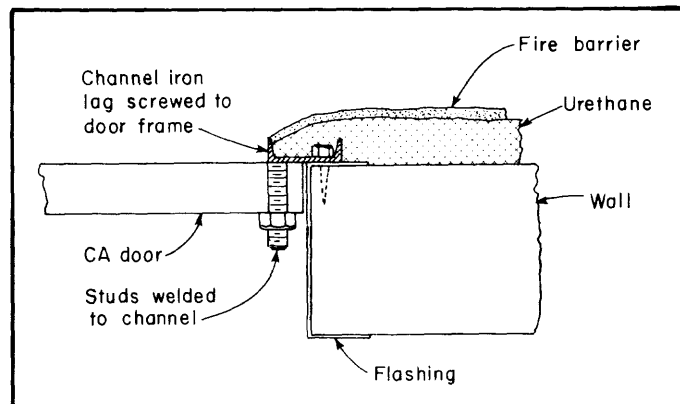

Commercial and handmade metal clad doors are surface sealed to the door frame and held closed with clamps (Figure 19). The seals commonly used with these doors are dry rubber gaskets, duct tape, or grease and caulking. Bolt-on CA doors are sealed to the door frame with caulking compound or heavy grease. Grease is preferred in many cases, because it can be easily removed from the door and door frame and, with care, can be reused several times. The base of the CA door is sealed to the floor with caulking compound. Sometimes an angle iron is screwed to the floor and caulked to provide a positive seal at the base of the door.

**Figure 19.** Outside Mounted Insulated CA Door Secured with Clamps

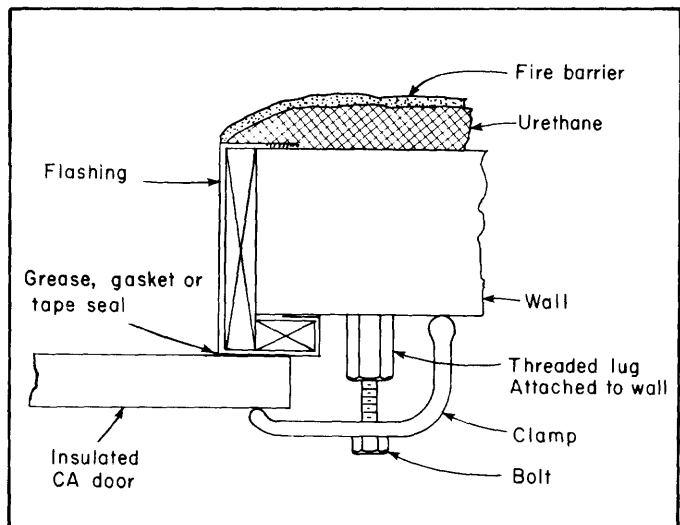

An access hatch in the gastight door allows persons to enter during pressure testing and during the operating season to remove samples of produce, to add bags of lime for CO<sub>2</sub> removal, or to permit simple repairs to be made inside the room. Locate this hatch to allow for easy access to the evaporator. It should be 24" wide and 30" high to allow passage of a person with self contained breathing equipment. The hatch is usually made of an acrylic sheet or a glass window sash attached to the surface of the CA door with studs and wing nuts or easy-opening, over-center latches.

Hinged access doors can be used and are usually secured with over-center latches and sealed with dry gaskets. A dry gasket is preferable to grease because people and equipment pass through the opening. Access doors can also be located at an upper level behind the evaporators. Some operators prefer to have access to the top of the bin stacks in addition to that gained from below. When entry into a CA room is required, observe the safety precautions listed in Appendix 2.

A porthole in the airtight door serves many functions. When workers are inside the room, locating and plugging leaks, the porthole can be used to pass messages and small pieces of equipment. It can also be opened slightly to equalize the pressure in the room when the oxygen is being reduced with an atmosphere generator. During the operating season, it can be used to smell ammonia leaks, burned electrical insulation and fan belts, or overripe apples, to listen for fan malfunctions, and to remove small samples of produce stored nearby.

Steel posts, pipes, channel iron, I-beams, and the like, set into the floor protect the door jams from forklift trucks. Make the door opening between posts 8' to 10' wide and of sufficient height to permit the passage of two stacks of nested bins or three stacked single bins depending upon the method of empty bin storage.

## ● Observation Window

Observation windows installed at the upper level behind the evaporator permit visual inspection of the blower units to determine the length and effectiveness of defrost cycles. Plastic streamers hung from the evaporator discharge locations assist in determining the adequacy of the air flow through the coil. The observation window also permits inspection of the stored product and permits observation of thermometers hung inside the storeroom. The field of visual inspection provided by the observation window will be greatly enhanced by installing an acrylic dome similar to that illustrated in Figure 20.

The observation window can also serve as a ventilation inlet in rooms refrigerated with ammonia to flush ammonia from a sealed room in the unlikely event of an ammonia leak. Since the concentration and time of exposure to ammonia determines the extent of ammonia

**Figure 20.** Acrylic Dome Window Permits Full Field of View Inside CA Room

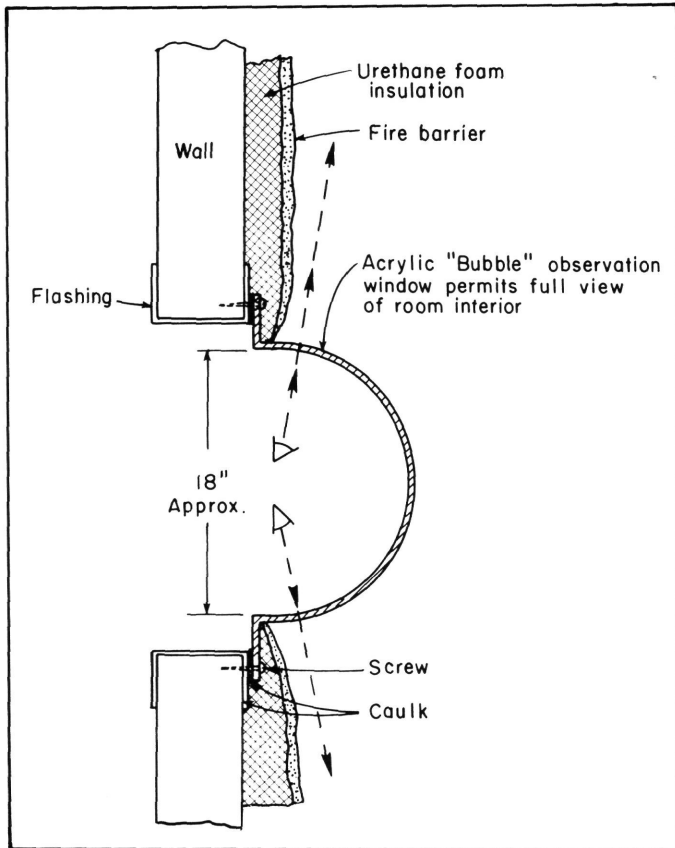

injury in the stored product, rapid ventilation of the room is important. Locate the window near the evaporator intake so ventilation and flushing the room with outside air is possible. Removal of the observation window and access hatch in the CA door permits cross ventilation of the room and insures rapid removal of ammonia. A second access hatch at the upper level behind the evaporators will serve the same purpose as the removable window.

● **Pressure Relief**

A pressure relief port will prevent the development of excessive positive and negative pressures which can cause structural damage to the room and the gas seal. CA structures have been damaged when CO<sub>2</sub> scrubber valves have malfunctioned and during the operation of atmosphere generators when port holes were not opened for pressure relief. Protection against the dangers of rapid changes in pressure is provided by the water trap pressure relief system shown in Figure 21.

Water trap systems (Figure 21) are commonly used for pressure relief. These systems are simple and reliable, although care must be taken to ensure the liquid does not freeze and that only a 1" liquid differential is allowed. Traps need to be refilled periodically because water is lost from evaporation and splashed out during the pressure relief function.

**Figure 21.** Pressure Relief Systems for a CA Room

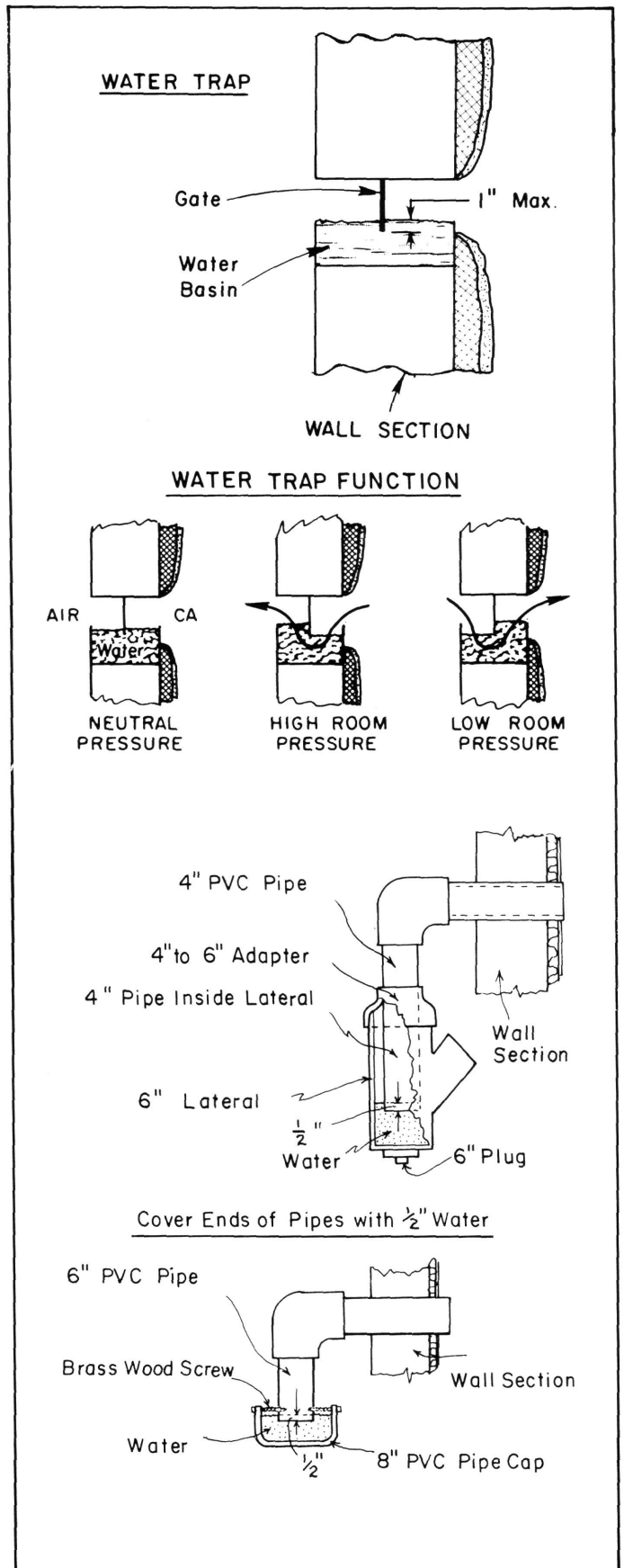

Spring loaded check valve systems (Figure 21) also provide pressure protection. These valves to operate at 1" of water pressure differential. They are much more expensive than water traps, but do not require the regular attention that water traps do.

Size a pressure relief system in proportion to room volume. Water tubes and drain taps small in cross sectional area relative to room volume may not relieve room pressure before structural damage occurs. This consideration is particularly important where carbon and molecular sieve CO<sub>2</sub> scrubbers are used. Experience in the CA fruit industry indicates that 1 square inch of open area in the relief system will handle 1,000 cubic feet of storage volume.

Breather bags reduce the small pressure unbalances that occur during CA operation. Small pressure changes may be caused by:

- Removal of CO<sub>2</sub> by a scrubbing system
- Pressure changes caused by high winds
- Barometric pressure changes in the atmosphere
- Defrosting of refrigeration coils
- The normal refrigeration on/off cycle

Connect breather bags to the CA room with 4" diameter PVC pipe (Figure 22). The pipe should enter the room in the upper corner behind the evaporator and extend into the room 2' or 3'. Place the pipe inlet in a zone of neutral pressure so the bag will accommodate both positive and negative pressure changes inside the room. Suspend the

breather bags from the ceiling in a hallway directly adjacent to the CA room.

Bags currently available have sufficient capacity for 20,000 to 30,000 cubic feet of empty CA storage volume. Two or more bags can be manifolded to a single room if more breather bag capacity is required (Figure 22). Commercially available bags contain 6" diameter connections, and these should be attached directly to the 4" diameter pipe with a reducer. Large pipe diameters, short runs, and a minimum of elbows ensure that the bag can respond to small but rapid pressure changes caused during the defrost cycle.

## • Penetrations

Pipes for atmosphere scrubbers, atmosphere generators, air inlets, lime rooms, defrost systems, evaporator drains, and expansion bags can all be foamed in place when the room is insulated. With careful planning, wall penetrations for these members can be made and short lengths of the proper diameter pipe can be positioned and sealed with the foam before equipment is installed. Also install and carefully foam the support brackets and hanger rods for evaporators before any hardware is put into the room. It is very difficult to obtain a good gas seal and insulation barrier behind and over the top of an evaporator that is hung in place before the foam is applied.

Figure 23 details penetrations for electrical conduits, refrigeration lines, gas sample lines and remote temperature probes. With this design, penetrating members can be installed after the urethane work is finished. It is also

**Figure 22.** Breather Bag Connection for CA Operation

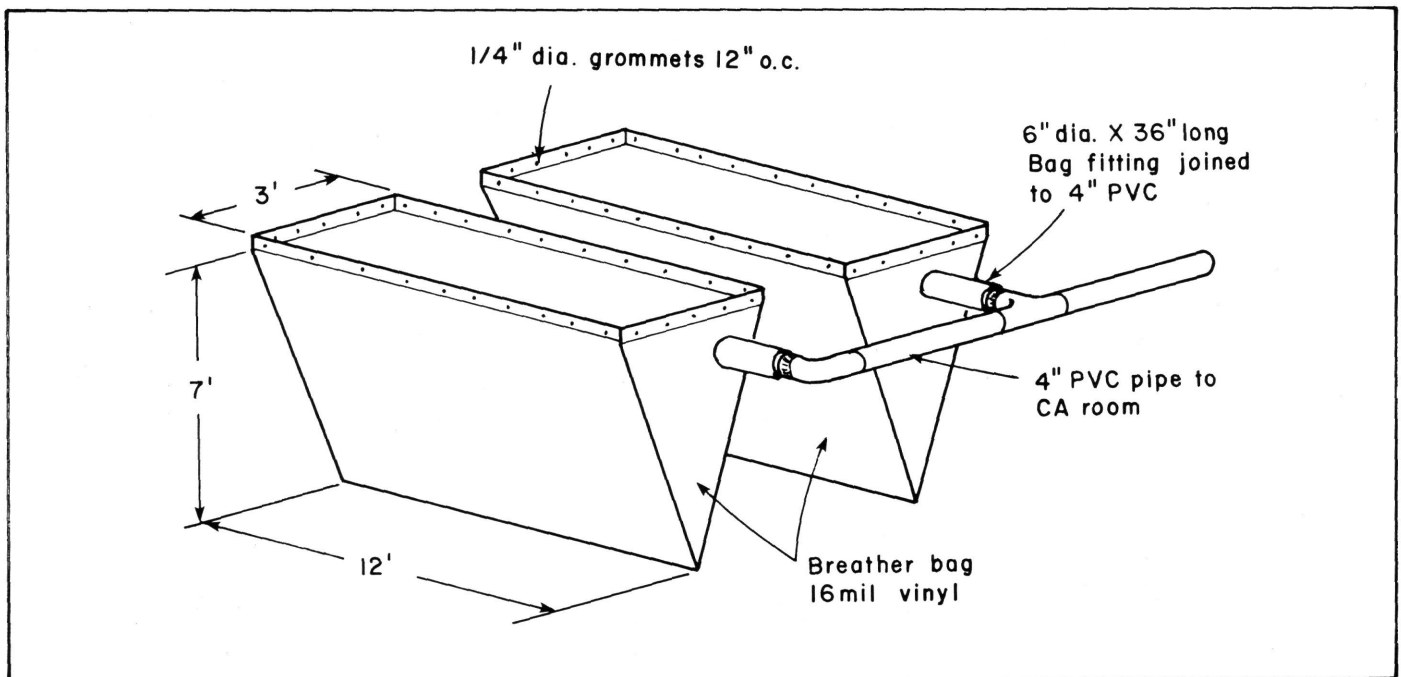

possible to incorporate thermal and vibration strain relief, particularly for iron or copper refrigeration lines, because resilient caulking (silicone) completes the gas seal. Vibration and thermal stresses have broken the gas seal in some situations where these lines were rigidly foamed in place.

The design shown in Figure 23 also permits some degree of misalignment in the penetrating members and the plastic sleeve. The inside diameter of the sleeve must be at least 1/2" more than the outside diameter of the penetrating member. Conduit lines can be run conveniently through similar but smaller sleeves. Fill the inside of all electrical conduits with silicone to prevent air leakage through the metal conduit. Install gas sample lines in a similar manner. It is easier to seal a single penetrating member in an individual sleeve than several members sharing a single large plastic sleeve. The exception is remote temperature sensor lead wires, which are small in size, and a bundle of these can share a single penetration.

**Figure 23.** Gas Seal Penetration

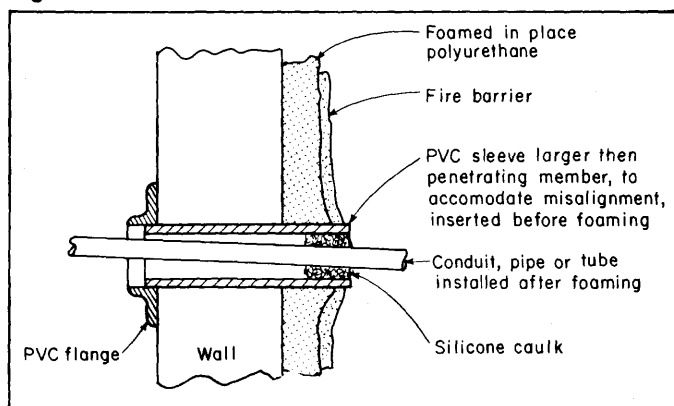

## Pressure Tests

Run a pressure test to determine gas seal integrity and the suitability of a new room for CA storage. Seal all known openings (doors, portholes, vents, pressure relief ports, sleeves, lines, penetrations, electrical boxes, etc.) and pressurize the room to a known (1" water gauge) pressure level and monitor the pressure loss with time. The pressure gauge readings are made (every 10 minutes), to develop a plot such as shown in Figure 24. The slope of the line drawn shows the rate of pressure loss. Leaky rooms that allow too much air entry for reliable CA storage yield a steep sloping line. Tight rooms lose pressure at a more gradual rate and will maintain the desired oxygen levels during storage.

The minimum slope of the pressure-time curve, or the tightness value, needed for successful CA storage depends on the CO<sub>2</sub> scrubbing method, the quantity of produce per unit volume of the room, and the oxygen

level to be maintained in the room. Figure 24 indicates the two pressure standards, or the length of time required for the pressure level in the room to drop 50%, that are currently recommended. One standard is for a "20-minute" room and the other is for a "30-minute" room. Pressure in a 20 minute room drops from 1.0" of water gauge to 0.5" in 20 minutes, and in a 30 minute room it drops from 1.0" to 0.5" in 30 minutes. Note that the corresponding time for the pressure to drop from .5" to .25" is also 20 and 30 minutes, respectively.

The "20 minute" standard is acceptable for all rooms operated at 3.0% oxygen regardless of the means of CO<sub>2</sub> removal used. Commercial experience indicates that a 20 minute room is also adequate for fruit storage at 1.25% oxygen if hydrated lime is used to maintain the desired CO<sub>2</sub> levels. Low oxygen rooms (1.25%) operated with carbon or water scrubbers should meet the "30 minute" pressure test standard. This tighter standard is needed because small amounts of oxygen are added by the carbon and water scrubbing systems.

Both pressure test standards are based upon a room packing factor of 20 to 21 pounds of fruit per cubic foot of empty storage volume. Equivalent CA cabbage packing factors in pallet box storage would be 17 pounds per cubic foot of empty storage volume. These tightness values have been obtained in present day construction and retrofit of old CA facilities. Some contractors in Washington State require a pressure test value in excess of 120 minutes for a 50% drop in initial pressure.

### ● Pressure Test Procedure

Run the pressure test before the fire barrier is applied to the urethane. The fire barrier makes it very difficult to locate leaks that were present and unnoticed during construction. The most accurate pressure tests are made when weather conditions, temperature, barometric pressure, and wind are all stable. The room should be empty and at ambient temperature with all refrigeration turned off. Also turn off all lights and fans in the rooms off, close all known openings in the room and seal all known leaks. Use the following checklist before running a test.

#### CA Storage Check List Prior to a Pressure Test

- CA door sealed?
- Access window sealed?
- Porthole closed?
- Scrubber lines capped or isolation valves closed?
- Breather bag connections capped?
- Pressure relief valves filled with water?
- Defrost line water traps filled with water?
- All penetrating members sealed in place?
- Electrical conduits and boxes caulked inside with silicone?

Figure 24. Pressure-Time Relationship Determined from Pressure Test

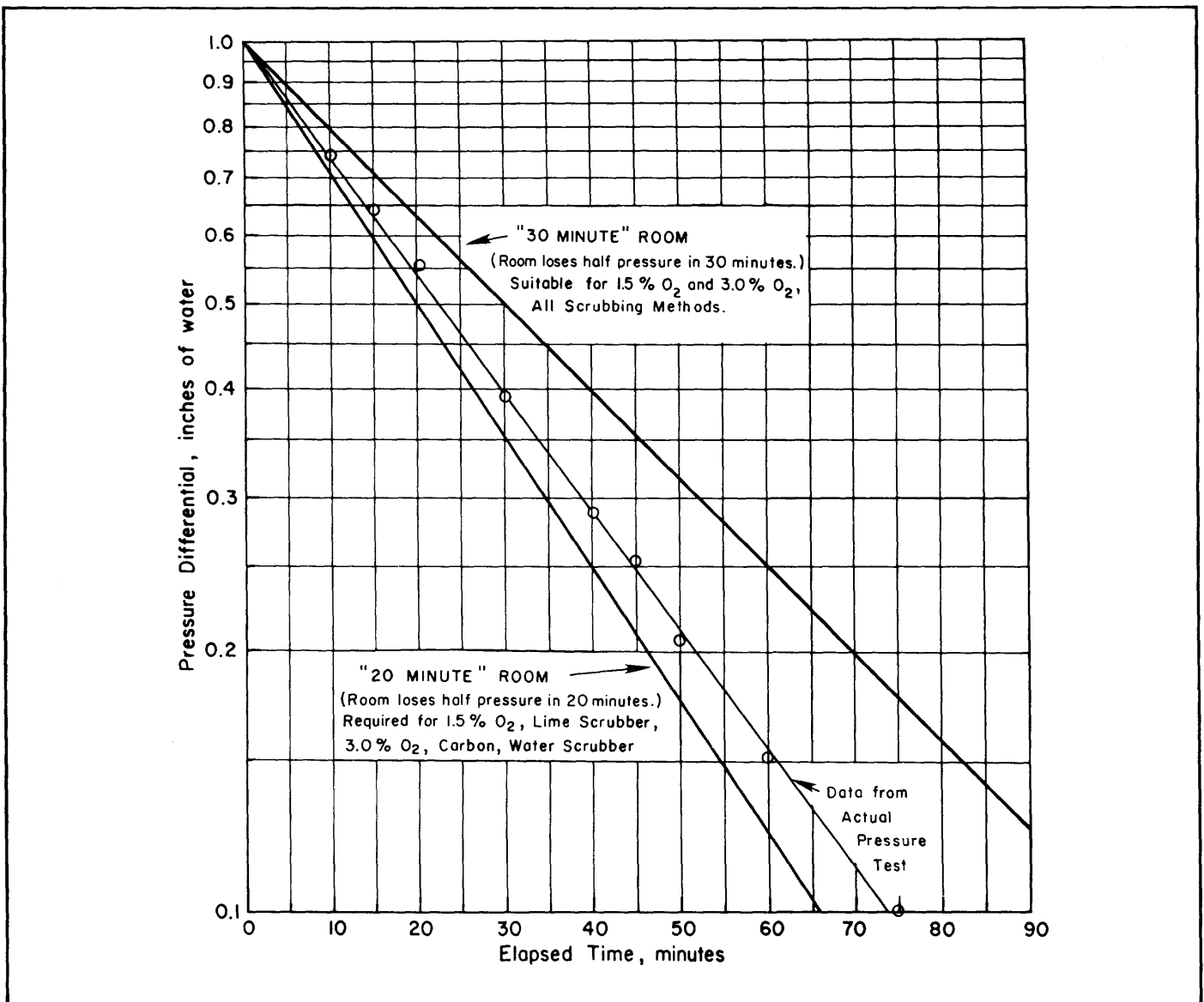

Connect a sensitive manometer, or pressure gauge, to the gas sample line at the room and set it to read the pressure difference between the inside and outside of the room. The manometer, or gauge, should be capable of resolving pressure differences as small as .05" of water gauge pressure.

Then pressurize the room to 1.1" of water gauge pressure with a vacuum cleaner, air fan, or scrubber blower. Never exceed 1.1" of pressure because structural damage may result. After the desired pressure is obtained, turn off the blower and close the air inlet valve. As soon as the pressure drops to 1.00" of gauge pressure, note the time, and record gauge readings every 10 minutes until the room pressure drops to 0.1". Pressure values below 0.1" tend to be unreliable; therefore, data in this range are not used in the pressure test. Plot the time-pressure data between 1" and 0.1" of pressure on

the graph in Appendix 4. Draw a straight line that fits best through the plotted points and compare the line for the tested room with the recommended standards already plotted on the graph. Use the example in Figure 24 as a guide.

Seal any major leaks or it may not even be possible to obtain the initial 1" pressure difference needed for a test. Have one or two people enter the room with repair materials such as silicone or butyl caulking and urethane foam sealer to patch the leaks. A pair of portable, two-way radios makes communication easier for the crews inside and outside the CA room. Use ladders, scaffolding, or an electric forklift to reach potential leaks high above the floor. Never use gasoline and propane powered equipment in a closed room.

After the persons enter the room, repressurize it again so they can find and patch the leaks until the room holds

pressure long enough to complete the pressure test. After all leaks have been found, retest the room to certify final air tightness. When the final test is made, have all CA equipment—burners, scrubbers, lime rooms, breather bags, etc.—connected to the room to make sure that no leaks exist in the plumbing or valving leading to this equipment. Keep a copy of the room test data for future reference.

## ● Locating Leaks

Leaks in new rooms are usually due to improperly sealed doors, gaps in the urethane foam insulation, poorly caulked electrical conduit boxes, or unsealed penetrations. Check all the items on the checklist again, seal them as necessary, and retest the room.

Random leaks can usually be found by listening in the room for the sound of infiltrating air. Leak detection generally is easiest when the room is placed under 1" of negative pressure (vacuum), which will cause air to be drawn in through the leaks. Very small leaks that produce no noise can sometimes be found with "soap" bubbles (1 part glycerine, 2 parts detergent in 3 parts water), applied with a paintbrush to an area of suspected leakage. The room must be under a vacuum so that bubbles form on the leaking surface.

The surface appearance of the urethane foam sometimes indicates where small leaks are likely to be located. Check areas with uneven application, rough surface texture, and joints between structural members and flat surfaces first. Smoke from ventilation smoke sticks or bee smokers may help in locating several small leaks or single large leaks that produce no noise. Persons inside the room watch for disruptions in stagnant puffs or streams of smoke, which indicate that air is being drawn into the room. If the room is tested under positive pressure with smoke, then smoke can be seen exiting the leaks. As with other techniques, use smoke in areas of high probability of failure such as around doors, penetrations, and at the floor-wall junction.

Ventilation smoke "candles" can be used in empty CA rooms pressurized to 0.75" of water gauge. These candles completely fill the volume with nontoxic smoke in 3 to 5 minutes. This smoke can then be seen emerging from the leaks. The exact location of the leak may still be difficult to find because the smoke may emerge from an opening some distance from the surface leak inside the room. When smoke candles are used, use enough to produce a volume of smoke 15 to 20 times greater than the empty store room volume and keep everyone out of the room. Also be careful when using smoke generators because of the combustible nature of many of the materials frequently found around the CA construction site.

If the floor or the floor-wall joint has a suspected leak, but it cannot be located, cover the floor with an inch of

water when the room is tested. An improvement in the pressure test will indicate that leaks were stopped by the water. If water cannot be seen flowing out of the leak, sprinkle sawdust on the surface of the water. When the water has drained out through the leak, the pattern of sawdust on the floor may indicate the location of the hole(s). If the room leaks only when it is loaded with produce, unload a center aisle, then flood the floor and sprinkle the sawdust before unloading the rest of the room. When the water has drained out, unload the rest of the room and observe the flow patterns left by the sawdust. It may be necessary to replace the floor in this situation.

The flooding technique may not be practical in large rooms because of the quantity of water needed. There is also some danger of softening or eroding the subgrade if a large quantity of water leaks through the floor. It is also possible to flood interior areas of the storage if the caulking under the CA door fails during this test. Over 60 gallons of water are needed for each 100 square feet flooded 1" deep.

## CA Equipment

---

Additional specialized equipment is required to establish, maintain and control the oxygen and CO<sub>2</sub> levels in controlled atmosphere storage. These items include: atmosphere generators, carbon dioxide scrubbers, and gas analysis and control equipment. The first CA fruit storage systems relied upon natural respiration processes to reduce the oxygen and raise the CO<sub>2</sub> levels in the storerooms. This technique is still used in commercial CA vegetable storage and in some apple storage installations, but fruit quality is improved if an atmosphere generator is used.

### ● Atmosphere Generators

Atmosphere generators quickly reduce the oxygen concentration when the room is sealed after harvest or resealed after some of the product has been removed during the operating season. Generators also maintain the desired oxygen concentration in CA rooms that develop large leaks during storage.

Open flame, single pass generators burn propane with oxygen from outside air and flush the vented CA room with the combustion products of nitrogen gas and carbon dioxide. Catalytic atmosphere generators recirculate the CA atmosphere through a heated catalyst bed where propane burns with oxygen to produce CO<sub>2</sub>. The CO<sub>2</sub> along with the nitrogen then returns to the room.

Several failures of the safety devices designed to stop the flow of propane if combustion ceases have occurred. (Both types of burners have temperature sensors that shut off the fuel supply if the flame goes out or the cata-

lyst heater fails.) In recent cases propane accumulated and exploded when electrical equipment was turned on in the CA rooms. To reduce this potential danger check all safety devices before burners are operated and install a propane alarm system in CA rooms where these generators are used.

Carbon monoxide has also been produced by atmosphere generators when the propane and oxygen levels were not properly adjusted. Carbon monoxide has not injured the stored commodity (apples), but it has overcome people who were working near the CA room when the doors were opened in the spring. Prevent this problem by making sure the burners are properly adjusted and by venting the rooms with outside air when the CA doors are opened or by opening closed CA rooms after workers have left the facility.

Another type of commercial atmosphere generator has recently been introduced for CA storage use. In this unit anhydrous ammonia ( $\text{NH}_3$ ) reacts with the oxygen present in the CA room. Room atmosphere recirculates through the generator where the ammonia gas reacts at high temperatures with oxygen to form inert nitrogen and water vapor. The advantages offered by this system are that no carbon dioxide, no carbon monoxide, and no hydrocarbons (e.g., ethylene) are generated. Combustion efficiency is dependent upon the combustion temperature and the ammonia-to-oxygen ratio. It may be desirable to install an ammonia alarm system with the unit. Ammonia alarms should also be installed in any ammonia refrigerated CA rooms.

## ● Carbon Dioxide Scrubbers

Three methods are currently used to remove excess carbon dioxide from the CA room atmosphere: fresh hydrated lime, water scrubbers, and commercial  $\text{CO}_2$  adsorption systems.

### Lime scrubbing

Freshly hydrated, high calcium lime [ $\text{Ca}(\text{OH})_2$ ] will remove carbon dioxide from the CA room. Bags of lime placed inside the room supplement other scrubbing methods during the oxygen pull down period. Lime can also handle the entire scrubbing load throughout the storage period.

Between two and five 50 pound bags of hydrated lime per 1,000 bushels of apples are required if lime is used to supplement other scrubbing methods. The exact amount is determined by trial and error; additional amounts can be added to the room with relative ease. The lower rate is usually sufficient for McIntosh storage and the higher rate is frequently needed for Delicious. Use 20 bags per 1,000 bushels of apples if lime is the only means of  $\text{CO}_2$  removal. Experience with CA cabbage storage indicates that forty 50 pound bags per 100 tons are adequate for the first 60 to 100 days with a second 40 bags good for

60 additional days and the third 40 bags good for only an additional 30 days.

Either "chemical" or "agricultural" hydrated lime can be used. Each type is suitable if it is fresh, high in calcium, and of adequate fineness. Particle size is indicated on the bag; at least 95% should pass a 100 mesh sieve. Chemical grade is usually finer than agricultural grade.

"High calcium" hydrate is more reactive than lime containing significant amounts of magnesium. The calcium and magnesium content is stated on the bag in terms of percent calcium oxide ( $\text{CaO}$ ) and magnesium oxide ( $\text{MgO}$ ). For efficient  $\text{CO}_2$  removal, the assay should show "70% to 75%  $\text{CaO}$ " and "less than 2%  $\text{MgO}$ ." Hydrated lime is made from the oxide form of lime, and therefore, the analysis relates to the oxide content. Hydrated lime showing an assay of "75%  $\text{CaO}$ " will contain 99%  $\text{Ca}(\text{OH})_2$ .

Only fresh lime is effective in removing carbon dioxide. The 50 pound bags of lime will weigh approximately 68 pounds when they have absorbed the maximum quantity of carbon dioxide. If "fresh" bags weigh more than 55 pounds reject the shipment and order new lime. The bags may have waterproof liners that must be punctured before the lime is effective for  $\text{CO}_2$  removal. A board with several nails driven through it can be used to punch a number of holes in the side and ends of each bag as it sits on a shipping pallet.

Lime placed directly in the CA room can be placed under the evaporator, in front of the door, or on top of the stack if it does not disrupt the airflow in the room. Some heat will be given off as the lime absorbs carbon dioxide, thus the room thermometer or refrigeration thermostat will not indicate the true temperature of the room if it is located in a dead air space near the lime. Therefore, place the lime downstream from the room thermometer in an area with good air movement.

Replace the lime when the  $\text{CO}_2$  level in the room exceeds the desired level. Spent lime (calcium carbonate,  $\text{CaCO}_3$ ) is still good for soil application, and it can be spread on the fields.

If lime is used to scrub all the  $\text{CO}_2$ , it is usually placed in an airtight box outside the CA room, adjacent to the wall where the evaporator is located (see Figure 25). The box is usually made of plywood or metal and is insulated and sealed with urethane foam. A volume of approximately 3.5 cubic feet for 50 pounds of lime is needed. The lime room door should be large enough to permit loading and unloading of palletized bags of lime with a forklift. Size the box to hold 10 bags of lime per 1,000 bushels of fruit or 40 bags of lime per 100 tons of vegetables.

Run 4" to 6" diameter pipe from the top of the lime box through the wall of the CA room (Figure 25). Run a similar pipe from the base of the lime box overhead and



**Figure 25.** Lime Room Connection for Carbon Dioxide Scrubbing

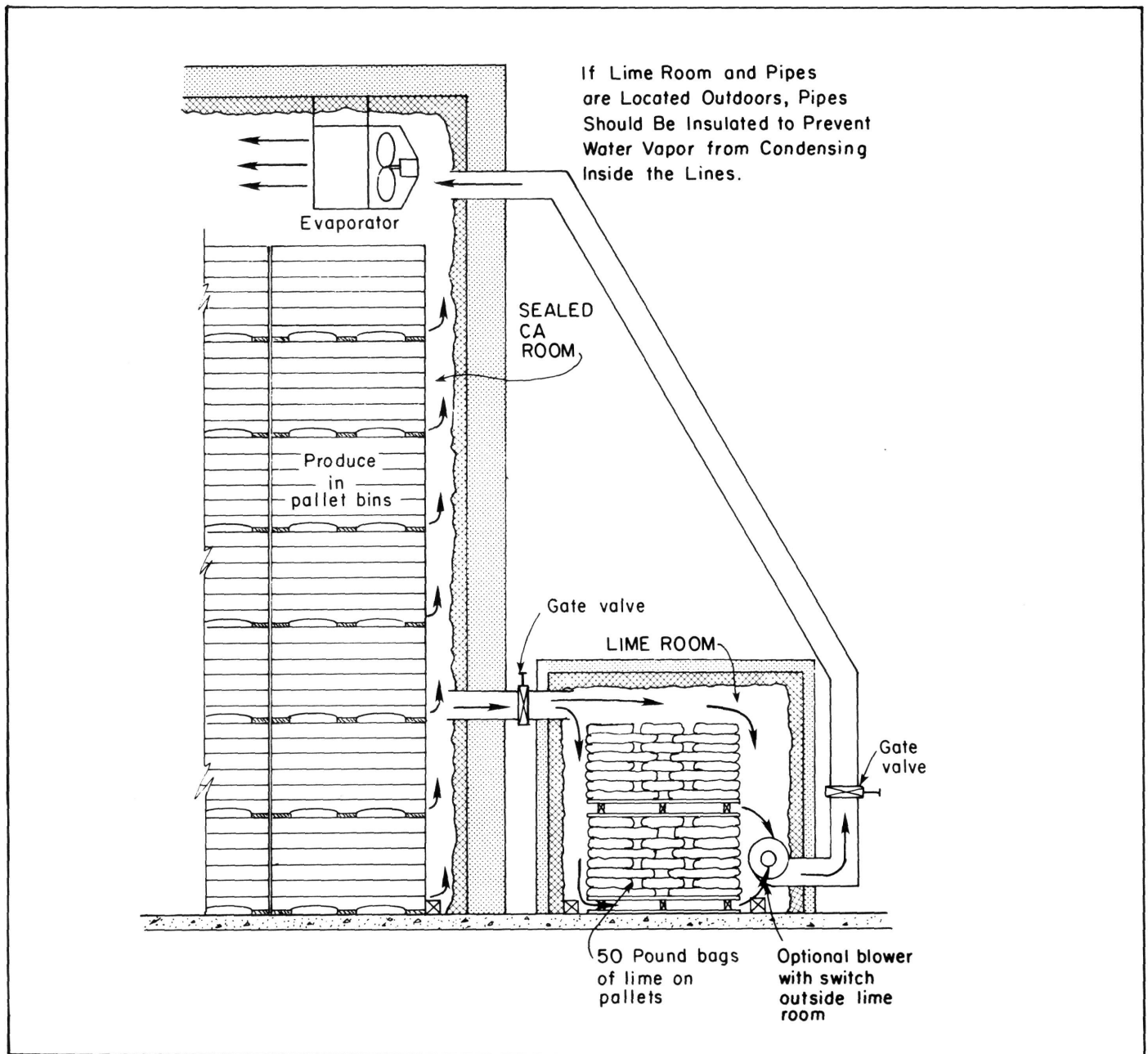

through the wall of the CA room in the vicinity of the evaporator inlet. The pressure changes developed by the evaporator fans are usually sufficient to move the room's atmosphere into the top of the box, downward through the stacks of lime, where it is scrubbed, out through the discharge line, and back into the storeroom. If circulation is not adequate or if smaller scrubber lines are used, install a small externally controlled centrifugal blower inside the lime room. Gate valves in the scrubber lines are used to limit scrubbing action or to isolate the lime box when lime is changed. If the lime room is located outdoors, insulate or run all scrubber lines inside the CA room to prevent moisture condensation.

### Carbon Scrubbers

A recent economic study in New York showed that, although the initial cost of carbon CO<sub>2</sub> scrubbers is high, the operating costs are fairly low; and the total cost over a 13 year operating period is competitive with lime and water scrubbing, if the scrubbers are properly matched for the capacity of the CA rooms. Carbon dioxide is adsorbed on the surface of activated charcoal granules in the scrubber bed. When the bed is saturated, carbon dioxide is desorbed from the activated charcoal with fresh air, that is circulated through the bed and exhausted outdoors. After the desorption cycle, air is purged from

the carbon bed before CA atmosphere is allowed to circulate through it again. Purging prevents the air in the bed from entering the CA room when the scrubber is switched back to the absorption cycle.

Once the timing of the desorption and purge cycles for a new charcoal scrubber has been adjusted, the amount of air added to the room is usually less than that required to maintain the safe oxygen level for storage. The CO<sub>2</sub> removal rates are determined by the number of hours the scrubber is operated each day. One large charcoal scrubber can be manifolded for two or more CA rooms. The scrubber can also be used to "blend" atmospheres between two or more manifolded CA rooms. Equip CA rooms with large pressure and vacuum relief ports to prevent gas seal failure and structural damage if the automatic valve controls malfunction or if manually operated manifold valves are incorrectly set.

### Molecular Sieve Scrubbing

Molecular sieve scrubbers adsorb CO<sub>2</sub> on the surface of a synthetic scrubbing medium. The process "strains" the circulated room atmosphere and captures CO<sub>2</sub> in much the same manner as carbon scrubbers. The CO<sub>2</sub> is desorbed from the sieve material by heating the bed several hundred degrees Fahrenheit and purging it with air. Molecular sieve systems require more energy to operate than carbon scrubbers because of the bed heating requirement.

### Dry Chemical Scrubbing

New types of chemical CO<sub>2</sub> scrubbers are being introduced. These use a proprietary dry caustic material in a closed container. The units appear to be an effective noncorrosive alternative to the caustic soda water scrubbers used previously. This CO<sub>2</sub> scrubber does not add any air to the CA room.

### Water Scrubbing

CA rooms refrigerated with brine spray defrost evaporators commonly use water to remove excess CO<sub>2</sub> from the room atmosphere. Water scrubbing of CO<sub>2</sub> has become less important in recent years because storage operators have shifted from brine spray defrost to other defrost systems. Most water scrubbers do not have sufficient capacity to remove all excess carbon dioxide during the early part of the storage season when respiration rates are high and when atmosphere generators are being used. Bags of hydrated lime are, therefore, stacked inside the CA room to supplement water scrubbers. After the first 60 days of operation, the water scrubber is usually adequate and it may be necessary to reduce the rate of CO<sub>2</sub> removal from the atmosphere by restricting the water flow. Small amounts of oxygen are also added to the CA room from the dissolved air present in the return water stream.

## ● Gas Analysis and Control

Presently oxygen and carbon dioxide concentrations are for the most part, measured with Orsat gas analyzers. These analyzers are accurate, inexpensive and easy to operate, clean, and repair. But Orsat gas analyzers are time consuming to operate and cannot be automated. Operators with large numbers of CA rooms might consider installing automated gas sampling and analysis equipment instead. Automatic oxygen control equipment can be interfaced with automated gas sampling and analysis equipment. The automatic analysis and oxygen control equipment has been developed for operating CA rooms close to the danger limit, 1.25% oxygen for apples. The cost effectiveness of control equipment has not been established for all CA operating conditions, but the potential benefit appears to be good in situations where low oxygen storage and multiple storerooms are operated.

Safe operation of all CA and low oxygen CA, in particular, is critically dependent upon the accuracy of gas analysis. A truly representative gas sample and a correct analysis are essential. Many thousands of dollars of produce has been damaged by low oxygen levels because analysis lines, fittings, and valves have leaked. Air unknowingly added to the gas sample from such leaks, gave high oxygen readings and the rooms were erroneously lowered below the oxygen starvation limits. Sample line leaks unfortunately usually go unnoticed until after the product damage has occurred.

Always install two gas analysis lines in each CA room. Install one for routine analyses, and a second short line to periodically perform an analysis right at the CA room. An Orsat or portable electronic oxygen analyzer can be used once a week for this analysis at the room. Place the sample line intake ends inside the room in an area with good atmosphere circulation and away from the burner, scrubber, and air inlet pipes. Use 1/4" soft copper tubing and for the short line. The longer line can also be 1/4" copper, although Tygon, polyethylene, and rigid PVC plastics are currently being used. Copper lines have failed because of salt corrosion and galvanic reaction with metal components, nails, strapping, and the like. Plastic is subject to mechanical damage and abrasion. Pressure test all lines at least once a year. Condensation may plug gas lines that are run long distances through cold areas. If lines are blocked or frozen, pressure test them to make sure that leaks have not developed.

Sample lines from several CA rooms can be brought to a central analysis station. (Electronic analyzers and CA controllers would also be centrally located.) A manifold and pump arrangement such as shown in Figure 26 may be installed to deliver the gas sample to the centrally located analyzer. Note that the sample does not flow through the pump because it may leak slightly and allow

**Figure 26.** Manifold, Analyzer, and Pump Arrangement for Gas Sample Analysis

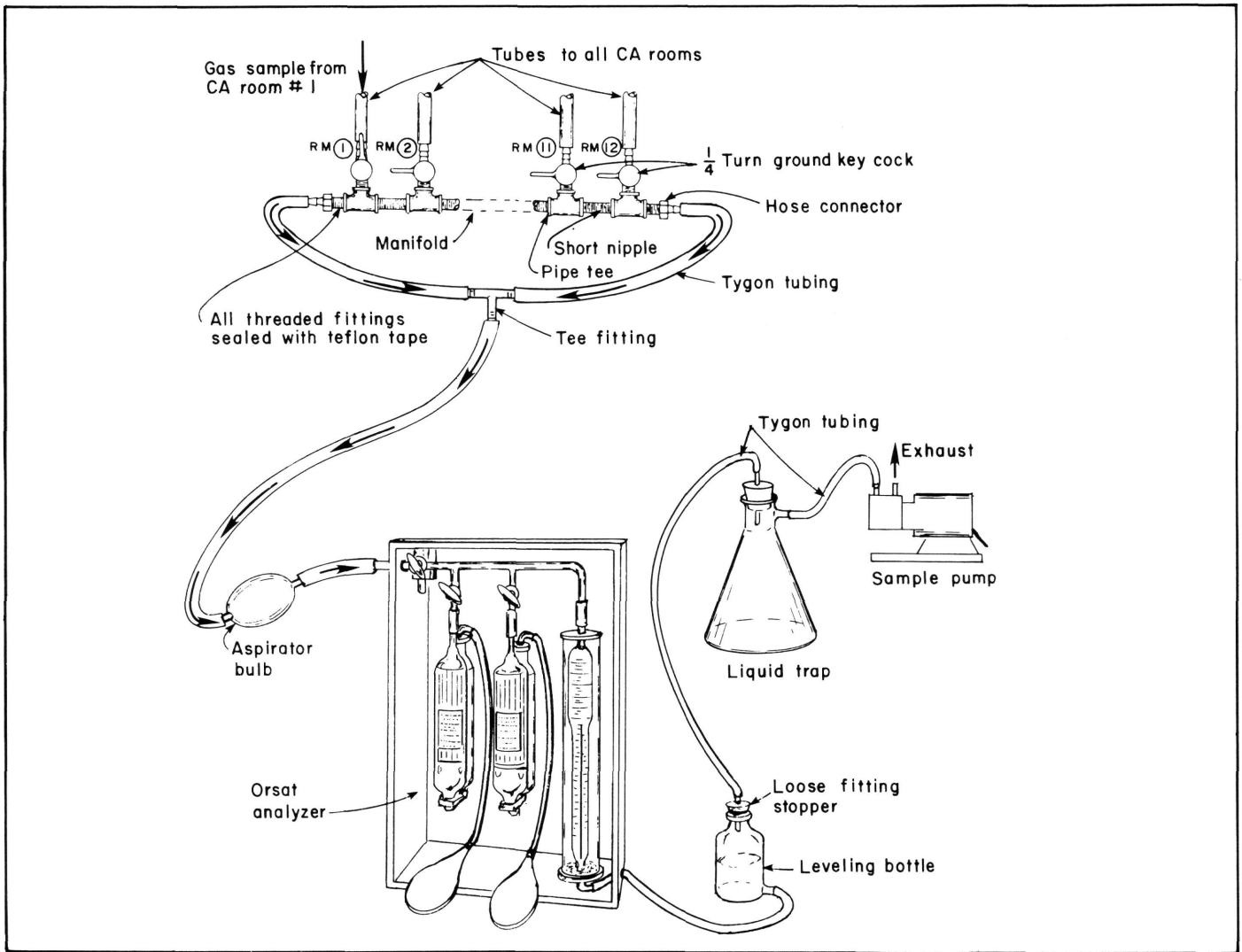

air to mix with the sample and give a false reading. The pump is used only to purge the sample line and manifold, or it may draw the sample through the analyzer as shown in Figure 26. Fit a water trap between the leveling bottle connection and the pump if a pump-through system is used.

Only use very high quality valves in the atmosphere sampling manifold. "One-quarter turn ground key cocks", available from scientific supply firms, have functioned very well in commercial CA applications. Quarter-turn valves are preferred because they are fast operating, and the handle position always indicates whether the valve is closed or open.

Automatic atmosphere controllers operate in conjunction with automatic gas analyzers either to pump air into the room if the oxygen level is too low or to start a carbon dioxide scrubber if the CO<sub>2</sub> level is too high. The analyzer/controller is capable of making many small adjustments daily and, therefore, is ideally suited for

maintaining close control of oxygen in low oxygen store-rooms. Considerable operator attention is required during the setup of these controllers, but once they are operating, very little work is needed to analyze and control the atmosphere in many CA rooms. Oxygen levels in these rooms should still be checked at the room once each week.

Manual control of the CA atmosphere is based upon daily analysis. Oxygen levels are maintained by adding air to the room through an air pipe. The pipe may contain a "regulated leak", a plug with a small hole in it. Leaks of various sizes are used depending upon the oxygen level in the room. Barometric pressure changes and room "pumping" due to defrost events provide the necessary air infiltration through the regulated leak. If oxygen levels are very low, a small centrifugal fan can be used to rapidly add air. This fan should be operated from a timer so that it is not forgotten and left on longer than needed. The porthole in the CA door may also be opened slightly to relieve pressure when the air-blower fan operates.

Carbon dioxide removal is controlled by the length of time the scrubber is operated each day. Lime scrubbers are regulated by the valve opening in a connecting line or the length of time that a circulating fan is turned on. There is no control of the scrubbing effect of lime placed inside the CA room.

## Controlled Atmosphere Storage Operation

---

Before CA rooms are loaded with produce, check all the controlled atmosphere equipment in the plant and prepare it for service. Fill and cool CA rooms rapidly to get maximum benefit from CA storage. It is particularly important to use proper room stacking patterns for rapid cooling and good atmospheric circulation, particularly if some of the blower units are turned off to conserve energy during storage. If lime is placed in the room, do not stack it on top of the bins in front of the evaporator discharge. Also do the following before the room is sealed:

- Place a ladder inside the room in an area beside the evaporators for minor repair work in the filled operating CA room. Refer to Appendix 3 for instructions before entering any CA room.
- Place calibrated, properly operating temperature sensors and thermometers in position.
- Check, adjust, and lubricate all air handling and defrost equipment well before closing the room.
- Look through the observation window to make sure that all fan motors and air streamers are visible and that all necessary lights operate.
- Fill the pressure relief ports with water.

Once the room is filled, caulk, seal, and clamp the CA doors in place. Provide additional regulated pressure relief by opening the porthole or air inlet pipe during generator operation. Then turn on the atmosphere generator to establish the controlled atmosphere.

As the atmosphere is established, carefully monitor it and frequently check oxygen and carbon dioxide levels. The oxygen level should gradually drop from 21% to the desired storage level. If the level does not drop rapidly or if it stabilizes at a level above that desired for storage or if it rises after the generator is turned off look for the following:

- **Generator operation.** Make sure the generator operates properly. If an oxygen burner is being used, make sure that the correct operating temperatures are being maintained in the burner and catalyst beds. Make sure that raw propane is not being fed to the room.

- **Leaks in the room or connecting equipment.** If the oxygen level rises after the generator is turned off, there are leaks in the controlled-atmosphere storage system. Refill all water traps, close all air openings, and do the following:

- a. Pressurize the room with air or nitrogen gas to 1" water pressure. Check the outside of the door frame and all penetrations and connecting equipment for leaks, and reseal where possible.
- b. If a water scrubber is being operated, turn off the aerator and take steps to eliminate bubbles in the return supply coming from the room. The water scrubber may be adding air to the room through the aerator or removing atmosphere from the room if bubbles are present in the return stream.
- c. If water is the only means of carbon dioxide removal and if carbon dioxide levels are extremely high, caustic soda (NaOH) can be added to the water or brine while the aerator is off. Add no more than 40 pounds of chemical per 100 gallons of water; then drain after 6 to 12 hours and replace with clean water. Use caustic soda as a last resort for it is extremely corrosive and will drastically shorten the life of galvanized equipment such as coils and blower units. It may be possible to quickly add lime to the room instead of using caustic soda.
- d. If a lime box is used, seal off the pipes that connect the box to the CA room. If the oxygen drops more quickly in the next 20 to 24 hours, the leak is in the box. Keep the box isolated from the room until the leak is found. Use air pressure in the lime box and soapy water to search for leaks.
- e. Flood the floor with 2" to 3" of water and see if the oxygen level drops. Stop adding water if it must be added frequently because the supporting soil may be washed away from under the floor. Pressure tests on older rooms may indicate acceptable leak rates for storage, but these rooms may develop leaks when the floor is loaded. If this is the situation, replace the floor after storage.

It is possible to complete a storage season with a CA room that develops leaks after pull down. Several procedures can be used to maintain CA conditions and minimize air infiltration:

- Operate the CA generator periodically to lower the oxygen level in rooms that are partially filled or rooms that have been opened and resealed.
- Flush out the oxygen with nitrogen gas from a liquid nitrogen supply. Approximately 1 cubic foot of nitrogen gas is required for each cubic foot of empty storage volume. Use a garden hose to pipe nitrogen gas from a cylinder or a liquid nitrogen hose to pipe

vaporized nitrogen from a liquid tank through the porthole and up to the air intake of the evaporator-blower unit. The atmosphere inside the CA room flushes out through the open porthole.

- Reduce air infiltration brought about by pressure differences within the room by operating the evaporator fans intermittently. The refrigeration system can be cycled on and off in 3 or 4 hour periods. Never use this procedure until the product has been completely cooled.

### Operating the CA Room

CA rooms can be intentionally operated at higher CA storage temperatures than would be used for air storage (e.g., McIntosh apple storage). If room temperatures are

lowered just before the room is opened, open the porthole to prevent a negative pressure from forming in the room.

The access window or CA door itself can be removed to ventilate the CA room. Rooms must be ventilated with fresh air for several hours before they are safe to enter. If an atmosphere generator has been previously used on the room, be careful of possible carbon monoxide poisoning of workers in the building. In this case ventilate the room to the outdoors or open the room after everyone has left for the night. Carbon dioxide dissolved in the produce tissue may impart a flat flavor to the stored commodity when the room is first opened. Normal flavor should return within 24 hours after the CO<sub>2</sub> diffuses out of the tissue.

# Appendix I- Load Calculation Example for a 15,000 Bushel Apple Storage

## Storage Structure:

60' long x 30' wide x 17' high  
 R-10 Floor, R-20 Walls, R-30 Ceiling Insulation  
 Storage capacity 15,000 42 lb units = 315 tons  
 (42 lb per bushel)  
 Storage volume = 60' x 30' x 17' = 30,600 cubic feet  
 (2 cu ft per bushel)

## Temperature Data:

$T_o = 75^\circ\text{F}$  Design Ambient Temperature  
 (Assume fruit temperature =  $75^\circ$ )  
 $T_i = 32^\circ\text{F}$  Storage Temperature  
 $55^\circ\text{F}$  Deep Soil Temperature (Assumed)

## Loading Rate:

10% daily or  $0.10 \times 315 = 31.5$  tons/day

## Cooling Rate:

Cool to  $32^\circ\text{F}$  in 24 hours,  $\Delta T = 43^\circ\text{F}$

## Infiltration:

Assume 2.4 air changes of  $75^\circ\text{F}$  air in 24 hrs from Table 10 (p. 36)

## Miscellaneous:

Lights @ 0.5 watt/sq ft, 10 hr/day; Motors @ 5 hp, 20 hr/day

## Calculations: (Maximum load will occur on 10th day of loading)

### Field heat,

$Q_1 = MC\Delta T$   
 $Q_1 = 31.5 \text{ Ton}/24 \text{ hrs} \times 2,000 \text{ lb}/\text{ton} \times 0.86 \text{ Btu}/\text{lb}^\circ\text{F} \times 43^\circ\text{F}$   
 $Q_1 = 2,329,740 \text{ Btu}/24 \text{ hrs}$

### Respiration Load,

$Q_2 = MK$

The average temperature during pulldown is assumed to be:

$$(75 + 32)/2 = 53.5^\circ\text{F}$$

Interpolating from Table 6 gives,

$$K = 2,370 \text{ Btu}/\text{ton}/24 \text{ hr}$$

$$Q_{21} = 31.5 \text{ ton} \times 2,370 \text{ Btu}/\text{ton}/24 \text{ hr}$$

$$Q_{21} = 74,655 \text{ Btu}/24 \text{ hr (for product loaded on day 10)}$$

Product loaded on days 1 through 9 = 283.5 ton.

Temperature of this product is assumed to be  $32^\circ\text{F}$ .  
 At  $32^\circ\text{F}$ ,

$$K = 700 \text{ Btu}/\text{ton}/24 \text{ hr}$$

$$Q_{22} = 283.5 \text{ ton} \times 700 \text{ Btu}/\text{ton}/24 \text{ hr}$$

(for product loaded on days 1-9)

$$Q_{22} = 198,450 \text{ Btu}/24 \text{ hr}$$

$$Q_2 \text{ for all product} = Q_{21} \times Q_{22} = 74,655 + 198,450$$

$$Q_2 = 273,105 \text{ Btu}/24 \text{ hr}$$

## Conductive Gain,

$Q_3 = 24 A(T_o - T_i)/R$  (Floor, walls, and ceiling computed separately)

$$Q_3 = (24 \text{ hr} \times (60 \times 30) \text{ sq ft} \times (55 - 32)^\circ\text{F}) / (10 \text{ hr sq ft}^\circ\text{F}/\text{Btu})$$

$$+ (24 \text{ hr} \times [17 \times (60 + 30 + 60 + 30)] \text{ sq ft} \times (75 - 32)^\circ\text{F}) / (20 \text{ hr sq ft}^\circ\text{F}/\text{Btu})$$

$$+ (24 \text{ hr} \times (60 \times 30) \text{ sq ft} \times (75 - 32)^\circ\text{F}) / (30 \text{ hr sq ft}^\circ\text{F}/\text{Btu})$$

$$Q_3 = 99,360 \text{ Btu}/24 \text{ hr (floor)}$$

$$+ 157,896 \text{ Btu}/24 \text{ hr (walls)}$$

$$+ 61,920 \text{ Btu}/24 \text{ hr (ceiling)}$$

$$Q_3 = 319,176 \text{ Btu}/24 \text{ hr (total)}$$

## Infiltration,

$$Q_4 = (h_o - h_i) NV/13.5$$

where  $T_o = 75^\circ$ ,  $T_i = 32^\circ$  and  $V = 30,600 \text{ cu ft}$  and  $h_o$ ,  $h_i$  and  $N$  from Tables 9 and 10

$$Q_4 = \{(38.62 - 11.76) \text{ Btu}/\text{lb} (2.4/24 \text{ hr})(30,600) \text{ cu ft}\} / 13.5 \text{ cu ft}/\text{lb}$$

$$Q_4 = 146,118 \text{ Btu}/24 \text{ hr}$$

## Equipment,

Lights:  $0.5 \text{ w}/\text{sq ft} \times (60 \times 30) \text{ sq ft} = 900 \text{ w} = 0.9 \text{ kW}$   
 $t_l = 10 \text{ hr}$

Motors: 5 Hp  
 $tm = 20 \text{ hr}$

## Equipment,

$$Q_5 = (\text{kW} \times 3430) t_l \times (\text{Hp} \times 2545) tm$$

$$= (0.9 \times 3430) 10 + (5 \times 2545) 20$$

$$= 30,870 + 254,500$$

$$Q_5 = 285,370 \text{ Btu}/24 \text{ hr}$$

Total cooling load,

$$Q_1 = 2,329,740 \text{ field heat}$$

$$Q_2 = 273,105 \text{ respiration heat}$$

$$Q_3 = 319,176 \text{ conductive gain}$$

$$Q_4 = 146,118 \text{ infiltration gain}$$

$$Q_5 = 285,370 \text{ equipment}$$

$$Q_t = 3,353,509 \text{ Btu}/24 \text{ hr}$$

## Capacity of Installed Equipment

Capacity =  $Q_t \times \text{SF} \times \text{DF}$ ; Use 1.1 for each factor

$$\text{Capacity} = 3,353,509 \times 1.1 \times 1.1$$

$$\text{Capacity} = 4,057,746 \text{ Btu}/24 \text{ hr}$$

$$= 4,025,076 \text{ Btu}/24 \text{ hr} \div 288,000 \text{ Btu}/24 \text{ hr}/\text{ton}$$

$$= 14.1 \text{ tons}$$

Note that this capacity value is also indicated in Figure 8 with 10 day loading.

**Table 9. Temperature-Enthalpy Relationships<sup>1</sup>**

T, °F	h, BTU/lb
0	0.84
5	2.29
10	3.80
15	5.40
20	7.11
25	8.94
30	10.92
32	11.76
35	13.01
40	15.23
45	17.65
50	20.31
55	23.23
60	26.47
65	30.07
70	34.10
75	38.62
80	43.70
85	49.44
90	55.95
95	63.34
100	71.76

<sup>1</sup>From Psychrometric Tables, ASHRAE.

**Table 10. Storeroom Volume-Infiltration Relationships<sup>1</sup>**

Storeroom Volume Cubic Feet	Number of Air Changes Expected in 24 Hours
1,000	15.5
2,000	10.6
4,000	7.2
6,000	5.8
10,000	4.4
15,000	3.4
20,000	3.0
25,000	2.6
50,000	1.8
100,000	1.2
300,000	1.0
500,000	0.8

<sup>1</sup>From ASHRAE data.

## Appendix II- Controlled Atmosphere Storage Room Safety Precautions

Occasionally, someone must enter a CA storage to obtain produce samples, to replace a broken fan belt or burned out motor, or to make other equipment repairs. The atmosphere in the CA room will not support human life and people have died of asphyxia while working inside CA rooms. It is essential that persons entering CA rooms understand the dangers and take all precautionary measures to insure their safety.

Make the following provisions for anyone who enters an operating CA room.

### Before Sealing the Room

- Install a removable access hatch in the gastight door which is at least 24 inches wide x 30 inches high for a person with self contained breathing equipment strapped to his or her back.
- Place a ladder inside the room near the refrigeration unit. Allow sufficient space to move and use the ladder around the equipment.
- Place a danger sign on each gastight door and remote access hatch. **DANGER - ATMOSPHERE INSIDE WILL NOT SUPPORT HUMAN LIFE** or an equivalent warning printed on the sign in red or orange letters at least 1-1/2 inches high.

### Upon Entering a Sealed CA Room

If you have a state CA registration and need to break the seal before the end of the initial period, notify the Department of Agriculture in advance. If you must go to an area inside the CA room where you cannot be EASILY DRAGGED TO THE DOOR, open and vent with air until the oxygen is 21% before entering (see next item on Symptoms of Asphyxia). If you need to enter a sealed CA room (an area from which you can be easily dragged-rescued) proceed as follows:

- Have at least 2 sets of tested breathing apparatus ready. If you don't own your own equipment, functional breathing equipment may be borrowed or rented. The breathing equipment should be fed with air (compressed or fan blown) not pure oxygen. The mask should be held in place with straps. Scuba diving equipment is dangerous to use because the mouth-piece may drop from your mouth if you fall.
- Check the breathing apparatus. Make sure it delivers air to the mask and that the tank is full of air. The two individuals using the equipment should put on the breathing equipment in normal air and use up a tank

of air while doing routine tasks. They can then become accustomed to the apparatus, learn something about its limitations and hear the alarm when the air level in the tank is nearly exhausted. The tanks should then be refilled prior to use in the CA storage.

- Review the symptoms of asphyxia so you won't take any chances.
- Remove the access hatch cover in the gastight door of the CA storage room.
- Have the repair person enter the CA room with breathing apparatus. The backup person must keep the repair person in sight. If backup can be achieved from outside the CA room, have the backup person ready to enter the CA room, but not using breathing support equipment until necessary. The back-up person may need to enter the CA room to keep the repair person in sight.

If both people are in the CA room and one warning bell rings to signal the tank is almost empty, both people should exit the CA room. If one must climb the ladder, the second should stay on the floor. If both need to climb the ladder to see each other, then drag-rescue cannot be accomplished and the room should be opened and vented with air before repair work is completed.

## Symptoms of Asphyxia

Be sure you understand the following listed symptoms of asphyxia before entering a sealed CA room.

**REMEMBER: THE CA STORAGE CONTAINS LESS THAN 5% OXYGEN**

**21% oxygen** - Breathing, all functions normal.

**17% oxygen** - Candle is extinguished.

**12-16% oxygen** - Breathing increased and pulse rate accelerated.

Ability to maintain attention and to think clearly is diminished, but can be restored with effort.

Muscular coordination for finer skilled movements is somewhat disturbed.

**10-14% oxygen** - Consciousness continues, but judgment becomes faulty.

Severe injuries (burns, bruises, broken bones) may cause no pain.

Muscular efforts lead to rapid fatigue, may permanently injure the heart, and may induce fainting.

**6-10% oxygen** - nausea and vomiting may appear.

Legs give way, person cannot walk, stand, or even crawl. This is often the first and only warning, and it comes too late. The person may realize he is dying, but he does not greatly care. It is all quite painless.

**Less than 6% oxygen** - Loss of consciousness in 30-45 seconds if resting, sooner if active.

Breathing in gasps, followed by convulsive movements, then breathing stops.

Heart may continue beating a few minutes, then it stops.



# Appendix III- Use of the Orsat Analyzer for CA Storage Room Atmosphere Analysis

## Analyzer Preparation

Refer to Figure 26 when reading this section.

1. Put distilled water into water leveling bottle. Leave water leveling bottle on table (not top of analyzer).
2. Put distilled water into water jacket around measuring burette (water magnifies numbers on the measuring burette).
3. Study the three-way valve. There will be a dot or a raised mark on the stopcock to identify position.
4. Remove stoppers with rubber bladders from absorption pipettes.
5. Open stopcock on absorption pipette nearest the measuring burette.
6. Turn three-way stopcock so dot is on right.
7. Use a funnel to put carbon dioxide absorbent (20% sodium hydroxide) into back side of absorption pipette. Fill both sides about 2/3 full.
8. Close stopcock on absorption pipette.
9. Raise water leveling bottle to fill measuring burette with water.
10. When measuring burette is full of water, crimp hose with finger.
11. Now turn three-way stopcock so dot is on your left (closed position).
12. Open stopcock to absorption pipette.
13. Lower water leveling bottle (release finger) to bring liquid in absorption pipette up to red mark on stem of absorption pipette. It probably can't be brought all the way up in this first operation.
14. If so, close valve on absorption pipette and open the three-way valve (dot to right) and raise water leveling bottle until water fills measuring burette.
15. Now close three-way valve by turning dot to your left side.
16. Open absorption pipette valve again and slowly lower water leveling bottle till liquid reaches red mark on stem of absorption pipette.
17. Close pipette valve.
18. Repeat this operation with oxygen absorbent.
19. Inflate air reservoir bladders slightly and plug them into the back sides of the absorption pipettes.

Figure 26. Manifold, Analyzer, and Pump Arrangement for Gas Sample Analysis. (Repeat)

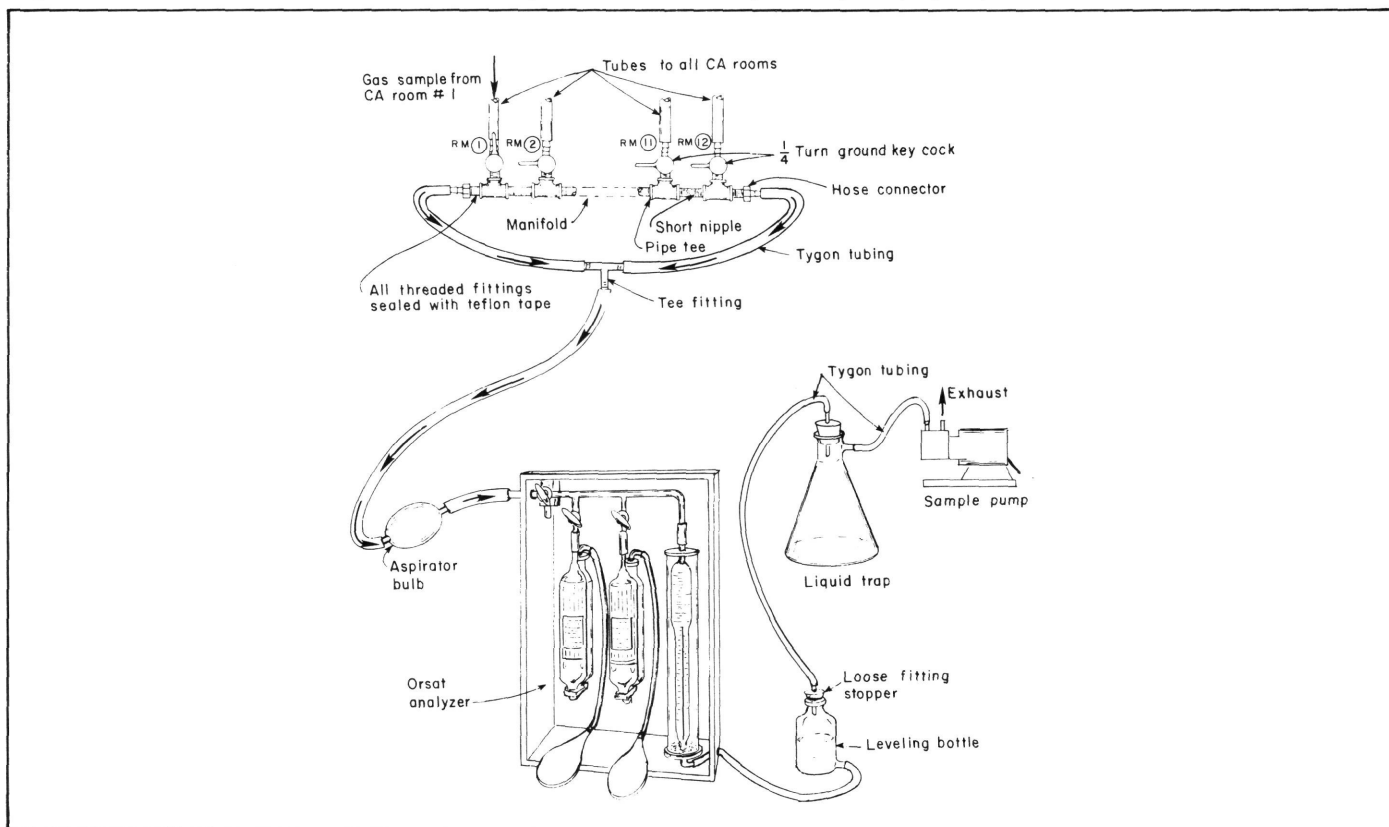

## Analyzer Operation

Most analyzers use a gas collecting bulb to pump a sample of gas from the CA room. Use a rubber or plastic tube to connect the gas collecting bulb to the sampling line or manifold fitting from the CA room(s). Use a short length of tubing to connect gas collecting bulb to left side of apparatus. If the sampling line to your CA room is over 20 feet long, you may want a small air pump to first purge air from the line.

1. Turn three-way valve so dot is at top.
2. Pump bulb 30-50 times. This pushes atmosphere out through water with the latter acting as a valve. This fills the line with a sample of gas from the CA room. Make sure gas collecting bulb does not leak.
3. You now have the sample tube filled with gas from the room. Turn three-way valve so dot is to your right.
4. Raise water level to top of measuring burette and crimp water line with fingers.
5. Turn three-way valve horizontal.
6. Slowly lower water leveling bottle releasing fingers from tube.
7. Lower water level to below zero mark and crimp water tube with fingers.
8. Allow about 5 seconds or whatever time is necessary for all the water from the sides of the measuring burette to drain down.
9. Turn three-way valve so dot is to your right.
10. Slowly raise water level to zero mark. If you go above zero mark, start over again with step 3 above.
11. When you have zero mark exact, turn three-way valve so dot is to your left.
12. The burette now contains exactly 100 cc of gas. Raise water leveling bottle so water level in measuring burette is slightly above zero.
13. Open stopcock to carbon dioxide absorbent (first absorption pipette).
14. Raise water leveling bottle till water completely fills measuring burette. When full, crease water tube with fingers to stop flow.
15. Now lower water level in measuring burette. Watch carbon dioxide absorbent rise in absorption pipette. Don't let absorbent go over red line on the stem of the absorption pipette.
16. Repeat this up and down operation two more times.
17. Now carefully bring absorbent exactly to red line, and close stopcock on pipette.
18. Hold water level in water leveling bottle exactly even

with water level in measuring burette. Allow 5 seconds or whatever time is necessary for drain down of water from sides of measuring burette.

19. Read [% carbon dioxide to nearest 0.1%] and record the % CO<sub>2</sub> reading.

Now raise water leveling bottle slightly and open stopcock on oxygen absorption pipette (second absorbent). Repeat step 12 through 19 on same gas sample. During step 15 and 16 hold the gas sample in the absorption pipette for at least 10 seconds on each of the three absorption steps. Absorption of oxygen takes longer than absorption of CO<sub>2</sub>. The second reading on the measuring burette is % CO<sub>2</sub> + % O<sub>2</sub>. Record this value to the nearest 0.1 %. Subtract the first reading from second reading to obtain the % O<sub>2</sub> and record the difference.

**Example:**

% CO <sub>2</sub> (first reading)	% CO <sub>2</sub> + % O <sub>2</sub> (second reading)	% O <sub>2</sub> (difference)
3.2	6.9	3.7

## Troubleshooting Analyzer

1. *Absorbent liquid won't rise to red line.* Put more air in air bladder.
2. *Liquid will not move down into the absorption pipette or will only move down a few inches when analyzing.* Let air out of air bladder.
3. *Liquid gradually falls in absorption pipette.* Either the stopcock or connector tube leaks. Clean the stopcock with a pipe cleaner and wipe lightly with stopcock lubricant, remove excess and seat tightly. Replace connector tube. See section on checking analyzer for leaks.
4. *Water is present in manifold or in stem of absorption pipette.* Crimp water line with finger immediately and close absorption pipette stopcocks. Turn three-way valve so dot is on right side. Lower water leveling bottle to draw in air and then turn three-way valve so dot is on your left. Raise water leveling bottle slightly and open stopcock on absorption pipette involved. Use air pressure to move water on down into absorbent. Close stopcock on absorption pipette.
5. *Absorbent liquid in manifold or in measuring burette.* Shut stopcock on absorption pipette involved. Turn three-way valve so dot is on your right. Lower water leveling bottle and run all water into bottle. Dump water and rinse water leveling bottle and measuring burette with clean water several times. Now purposely run a **little** water over into pipette involved. Proceed with step 4 to clear line of water.
6. *Burette has clinging water droplets when drained.* Add 2 drops of detergent into water. Change water (preferably distilled) occasionally.
7. *Erratic, nonreproducible readings.* See "Checking Analyzer for Leaks".

## Normal Care of Analyzer

---

1. At end of season remove pipette and three-way stopcocks from analyzer. Hang them on or near the analyzer. This will preclude freezing-up during the summer. To clean apparatus, **cut** off rubber or Tygon plastic connectors on absorption pipettes and measuring burette. Remove and dump absorption liquids down drain. Clean pipettes well with water. Hang upside down to dry. Replace when dry. Replace Tygon and/or rubber tubing.

2. Replace absorbing liquids when they are used up. Check them periodically. You should get the same reading of carbon dioxide with 3 as well as 5 washings. If the indicated concentration goes up a little with the fourth and fifth washings, the liquid is getting weak or the analyzer leaks. When the carbon dioxide absorbent is completely worn out, you will see crystals form across top of the absorption pipette. The carbon dioxide absorbent should last a complete season. Analyze air to check the oxygen absorbent. You should get close to 20.8% oxygen in air with three washings. If you only get something less than 20%, you know the absorbent is weak. This absorbent should also last all season, but it may not.

3. Use distilled water if possible in water leveling bottle to prevent fogging of measuring burette. If the inside of the measuring burette gets greasy, wash it out with soapy water. Then put 2 drops of detergent into the analyzer water.

4. Clean glass manifold, glass tubing, and stopcock holes with pipe cleaners.

5. Don't let apparatus freeze (32°F).

## Checking Analyzer for Leaks

---

1. If all stopcocks are lubricated and firmly seated, there should be no leaks. However, if you get erratic readings,

something is probably leaking. If you get 5% carbon dioxide with three washings and with a fourth get 4.2%; there is probably a leak in the analyzer.

Turn the three-way stopcock so dot is on your right. Raise water level in measuring burette to 2%. Turn three-way valve so dot is on your left. Blow lightly on water leveling bottle to raise water level in measuring burette to 4%. Clamp off water tube with fingers. Hold pressure in measuring burette for a minute. Now release pressure by removing fingers from tube and hold water level in bottle even with water level in measuring burette. It should again read 2%. If it reads higher than the original reading, check for leaks around connector at top of burette and at three-way valve and at the two stopcocks.

2. Check gas collecting bulb at least once a week. Disconnect bulb from analyzer. Squeeze bulb. Shut off tubes on both sides of bulb. Bulb should not inflate. Check leather or plastic gaskets. Sometimes the check valves do not seat properly. Remove and reseal them.

3. Be sure rubber or plastic tubing connected to sampling tube or manifold does not leak. Shut off rubber or plastic tubing at connection with fingers and repeat 2 above. The gas manifold can be tested in a similar manner. Sample lines to the CA rooms can be blocked inside the room before the room is sealed and checked in the same manner.

4. Erratic and false readings can be obtained if there is a leak from the front to the back of an absorption pipette. Leaks happen when one of the glass tubes in the absorption pipette falls through the glass plate into the connector between the two parts of the absorption pipette.

Remove the absorption pipette from the analyzer. Empty out the liquid and tap the absorption pipette while it is upside down until the glass tube falls back into place. (This accident is most likely to happen during rough handling in transit from the maker of the analyzer.)

# Appendix IV- Pressure Test Data Sheet

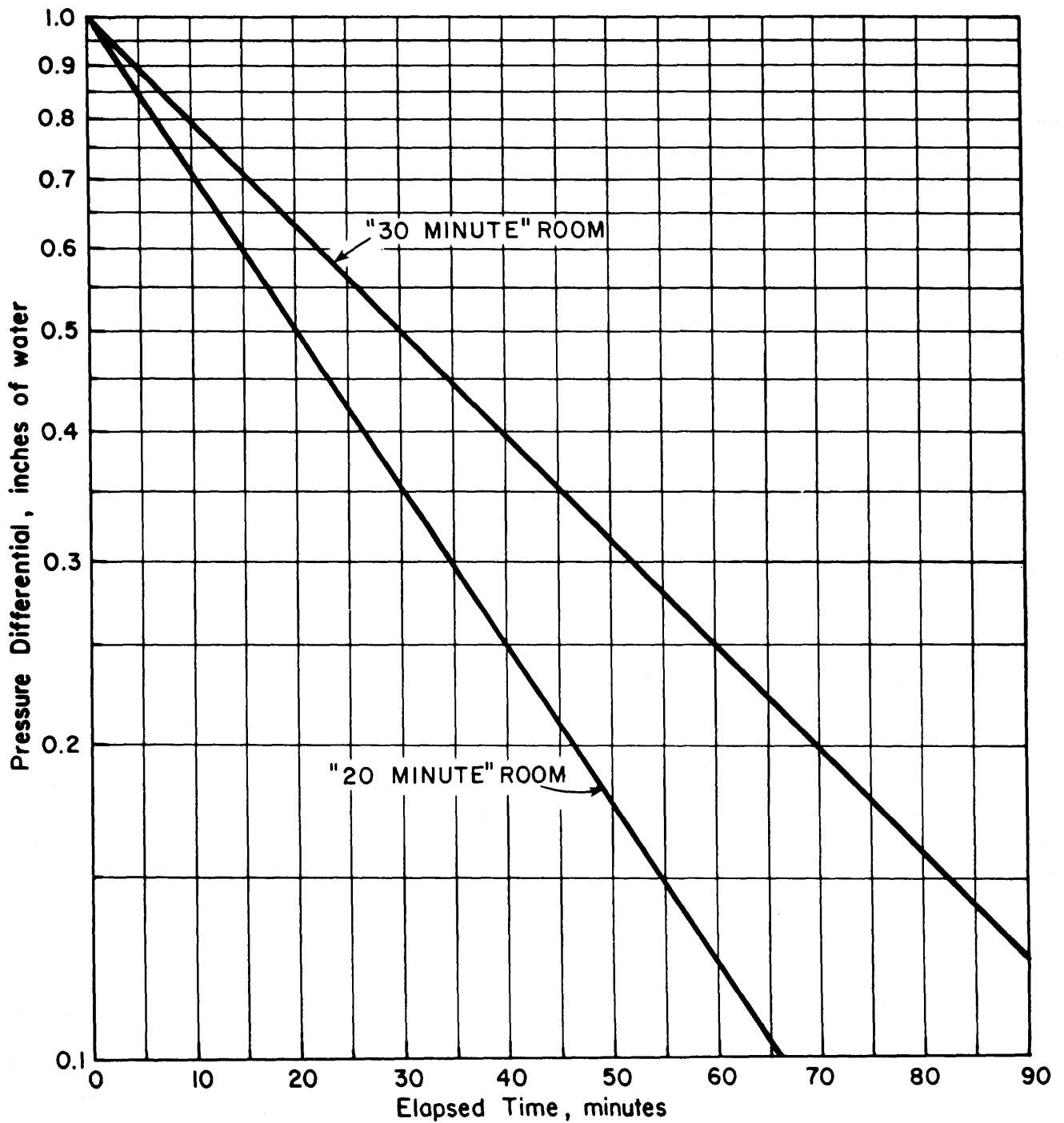

STORAGE OWNER \_\_\_\_\_ DATE \_\_\_\_\_

STORAGE LOCATION \_\_\_\_\_ ROOM # \_\_\_\_\_

REMARKS:

# REFERENCES

---

- ASHRAE. 1981. *Handbook of Fundamentals*. American Society of Heating, Refrigerating and Air-conditioning Engineers, Inc. 1791 Tullie Circle NE, Atlanta, GA 30329.
- ASHRAE. 1982. *Handbook of Applications*. American Society of Heating, Refrigerating and Air-conditioning Engineers, Inc. 1791 Tullie Circle NE, Atlanta, GA 30329.
- ASHRAE. 1965. *Fruit Storage*. Proceedings of the symposium presented at the July 5-7 meeting at Portland, OR. American Society of Heating, Refrigerating and Air-conditioning Engineers, Inc. 345 E 47th St., New York, NY.
- Bartsch, J. A. 1981. *Pressure Relief for Controlled Atmosphere Storage*. Agricultural Engineering Idea Sheet 67. Cornell University, Ithaca, NY 14853.
- Bartsch, J. A. and G. D. Blanpied. 1982. *Temperature Monitoring Systems for Cold Storage*. Agricultural Engineering Extension Bulletin 430. Cornell University, Ithaca, NY 14853.
- Blanpied, G. D. 1981. *Relative Humidity as Affected by Room Temperature and Coil Type*. Unpublished data presented at New York State Fruit Storage Schools.
- Factory Mutual Engineering and Research Corporation. 1983. *FM Approval Guide, 1983 Equipment, Materials, Services for Conservation of Property*. Edited by Eleanor Knight. FM Systems, 1151 Boston-Providence Turnpike, Norwood, MA 02062.
- Furry, R. B., R. M. R. Isenberg, and M. C. Jorgensen. 1981. *Postharvest Controlled Atmosphere Storage of Cabbage*. Search: Agriculture. Cornell University Agricultural Experiment Station, New York State College of Agriculture and Life Sciences. #19, ISSN 0362-2754. Ithaca, NY 14853.
- Furry, R. B., J. A. Hicks, M. C. Jorgensen and J. A. Bartsch. 1984. *Controlled Atmosphere Storage of Celery*. Paper #84-4038. The American Society of Agricultural Engineers. St. Joseph, Michigan 49085.
- Henderson, Y. and H.W. Haggard. *Noxious Gases and the Principles of Respiration Influencing Their Action*. Reinhold Publ. Corp., New York, NY.
- Lorenzen, R. T. and G. D. Blanpied. 1963. *Some Experiences with Water Vapor Condensation in Controlled Atmosphere Apple Storage Structures*. American Society of Agricultural Engineers Paper No. NA63-301. ASAE, St. Joseph, MI 49085.
- MWPS. 1982. *Structures and Environment Handbook*. Midwest Plan Service, 10th Edition. ISBN 0-89373-050-9. Iowa State University, Ames, IA 50011.
- Meffert, H. F. 1968. *Factors Influencing the Operation of C.A. Stores*. The International Institute of Refrigeration. Proceedings of the 5th International Congress of Refrigeration. Paris, France.
- Mitchell, F. G., R. Guillou, and R. A. Parsons. 1972. *Commercial Cooling of Fruits and Vegetables*. California Agricultural Experiment Station Extension Service Manual 43. Agr. Publications, University of California, Berkeley, CA 94720.
- Ryall, A. L. and W. J. Lipton. 1979. *Handling, Transportation and Storage of Fruits and Vegetables*. Vol. 1, Vegetables and Melons. AVI Publishing Co. Inc., Westport, CT.
- USDA. 1962. *Cooling Apples in Pallet Boxes*. Agricultural Marketing Service Marketing Research Report No. 532.
- USDA. 1968. *The Commercial Storage of Fruits, Vegetables, and Florist and Nursery Stocks*. Agricultural Handbook No. 66. U.S. Government Printing Office, Washington, DC 20402.
- Wills, R. H. H., T. H. Lee, D. Graham, W. B. McGlasson, and E. G. Hall. 1981. *Postharvest - An Introduction to the Physiology and Handling of Fruits and Vegetables*. AVI Publishing Company, Inc., Westport, CT.