

COOPERATIVE EXTENSION SERVICE • MICHIGAN STATE UNIVERSITY

Gravity Drain Gutters for Swine Manure Systems

Authors

Daniel J. Meyer, Pennsylvania State University
Richard K. White, Ohio State University

Reviewers

Ted J. Brevik, University of Wisconsin
LeRoy W. Cluever, South Dakota State University

The handling characteristics of swine manure depend upon the age of the pigs, the ration fed, and water usage. Manure may be removed from a swine barn by: (1) manual or mechanical scraping, (2) intermittent flushing with dump tanks, siphons or manually controlled valves, (3) continuous flushing, and (4) gravity draining. Scraping works best for long barns (over 100 ft.) such as grower-finisher or farrow-nursery barns where the slotted floor area is in one line. Scrapers or flush systems operate with or without slotted floors. Flushing requires large amounts of water (about 50 gal./ft. of gutter width). This is not practical in all areas because of odor nuisance potential.

Frequent removal of manure from a building has the following advantages when compared to a slotted floor placed over a below-floor manure storage:

- Building remodeling is easier than with deep below-floor storages.
- Air contains less corrosive gases which adds to the life of the continuous running winter fan.
- A central manure storage can be utilized for several buildings instead of constructing a separate storage under each building.
- Sanitation and clean up between groups are more easily accomplished in farrowing and nursery barns.
- Fuel bills may be lower because winter fan rates are not based on odor levels (i.e., 20 cfm vs. 35 cfm per crate—MWPS rates).
- Swine and operating personnel are exposed to lower pit gas concentrations in the building.
- There is less metal deterioration (slats, feeders, and heaters) in buildings.

Gravity drain gutter systems can be utilized for handling liquid manure from swine of all ages. Gutter shapes used today are a modification of the deep, narrow gutter developed in the early 1960's (Fig.1). These gutters depended on the pigs working the manure to them. Modifications to the original 6-inch-wide gutters include wider top widths, rounded bottoms, flatter slopes to the bottom, and shorter lengths.

The "Y" and "V" gutter gravity drain systems have disadvantages when compared to slotted floors over manure storages in that they are more complicated to build, and result in higher total manure system costs.

Research on gas production from nursery manure has shown that ammonia (NH_3) and hydrogen sulfide (H_2S) gas production vary with length of storage time and manure temperature. Neither NH_3 nor H_2S gas is produced until 4 days of storage. To minimize gas production, therefore, a gravity drain gutter should be sized to fill within 4 days. The high temperature trial (73° F.) in this study had three times the H_2S gas production rates of the low temperature trial (60° F.). Several producers have confirmed these data in their hot nurseries with shallow pits that are not emptied for 3-4 weeks. Steel feeders and wire flooring corroded and needed replacement in only 2-3 years.

A farrowing barn with a partial above-the-floor pit had an average H_2S concentration of 2.17 ppm. in the exhaust air. Three other below-the-floor partial pit farrowing and finishing barns averaged only 0.12 ppm. H_2S in the exhaust air. Researchers concluded that the above-the-floor manure storage caused higher manure temperatures than those in the other below-ground level storages.

Design of Gravity Drain Gutters

Designing a gravity drain system involves its shape, slope, length, outlet, and slat type.

Gutter shapes may vary considerably (Fig. 1), but most of them have in common a narrow section at the bottom of the gutter which receives all the liquids and part of the solids, depending on the slope above it. A minimum manure depth of 12 in. has worked most successfully for flow toward the outlet when the plug is pulled. The total depth of regular and modified Y and V gutters varies from 16 to 36 in. These modified gutters extend under totally slotted 7-ft. farrowing crates and 8-ft. nursery pens. A common feature in these modified gutters is the bottom section which is narrowed to 6-8 in. This limits the number of days of storage needed for the minimum 12-in. draining depth.

Two types of **side slopes** to the gutter have been used. The first is a self-cleaning slope utilizing a minimum of a 1 in. rise per 1 in. run for farrowing and 1 in. rise per 3/4 in. run for nursery. These steep slopes work well for narrow nursery pens (4 ft.) housing single litters. However, these steep slopes require excavation that is too deep for farrowing crates and long nursery pens which have totally slotted floors. The second type has flatter slopes to decrease construction difficulty and cost. The slopes being used are 1-2 in. per foot for farrowing and 3-4 in. per foot for nurseries. Because these flatter slopes accumulate manure solids and feed they should be hosed or scraped off every 1-2 weeks to keep the ammonia levels down and to control flies. A combination of the first and second type of slope is being used in totally slotted farrowing crates and nursery pens. It involves placing the self-cleaning steep slopes under the slotted floor sections with the heaviest manure concentration. The flatter slopes are used under the remainder of the floor section.

If concrete is used allow it to cure 4-6 weeks before paint is applied to the surface to keep it smoother over its lifetime and easier to wash down. Epoxy and polyester resin and polyurethane paints have been used successfully, but concrete must be clean and cured before applying them. Thick rigid plastic material is an alternative to concrete. Start the slope after at least a 3-in. vertical drop below slats so the manure can fall free of the slotted floor.

Gutter **length** should be a maximum of 40 ft. for farrowing or nursery barns and 70 ft. for grower and finisher barns. If a center plug is used, the length can be doubled since the gutter drains from both ends to the middle. The depth can be increased to build up more flush force for longer gutters. However, the longer draining intervals allow (1) feed and manure solids to build up in the bottom and (2) gas production rates to increase. One to two inches of water should cover the bottom of the gutter before using it the first time. This initial water also helps longer gutters to drain cleaner.

The **longitudinal slope** of the gutter should be about 1 in. of drop in 20-40 ft. If the gutter slope is steeper, solids remain on the upper end when the liquids flow out. Expect a small deposit of solids on the upper end of the gutter as normal.

The preferred **slat type** over the gutter is one with a high percentage open area, such as woven wire. The high percentage open area allows for easy visual checking to see how full the gutter is, and how much manure has built up on the slope above the gutter. This type of slotted floor also allows easier slope cleaning with a hose or a high-pressure washer.

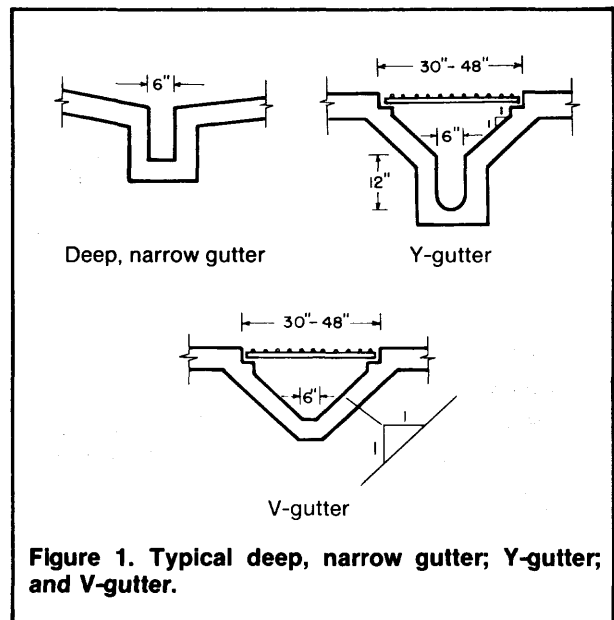

Figure 1. Typical deep, narrow gutter; Y-gutter; and V-gutter.

The **outlet** from the gutter must be equipped with an easy-to-remove watertight plug. Three types are shown in Figure 2. Fit the plugs into a 90-degree elbow or a tee. It is better, in case a waterer leaks or breaks, to have an overflow as part of the plug. The one shown has a gas trap built into it to prevent backdraft of pit gases in case the barn has negative pressure ventilation. Locate the plug outside the pen or crate to keep pigs from falling in unless a permanent guard is used. For a multiple room facility, consider locating the nursery room plugs in a common alley outside the rooms (Fig. 3). The main sewer line can be buried outside the perimeter of the barn in case access is needed for maintenance. If the rooms are drained individually, a 6-in. diameter main sewer pipe is adequate. If the barn has 4 or more rooms, and all gutter plugs will be pulled in a short interval, consider an 8-in. pipe.

Floor Cross-Sections of Gravity Drain Gutters

Farrowing

Nine cross-sections for farrowing crates are shown in Figures 4A through 4J. Figures 4A, 4B, and 4J are examples that can be used in remodeling situations to build above the floor, whereas the other cross-section examples require new sites or the removal of portions of existing concrete floors. Only Figure 4F shows the steep slopes which are self-cleaning; the others require periodic cleaning.

The example in Figure 4A utilizes plastic gutters for the front 12 in. of slats and 30-36-in. slats in the rear. The boards in the center section could be replaced with concrete if the crates are at floor level. The concrete center section should be finished smooth for the pigs to prevent knee abrasions. Caution should be exercised when applying concrete sealers because they can cause the concrete to become too smooth for the pigs and sow to stand.

The Figure 4B example utilizes a plastic gutter in the rear with a thick plastic sheet attached to it. A 3-6 in. clearance between the flooring and the start of the front slope is needed for access to wash down feed and

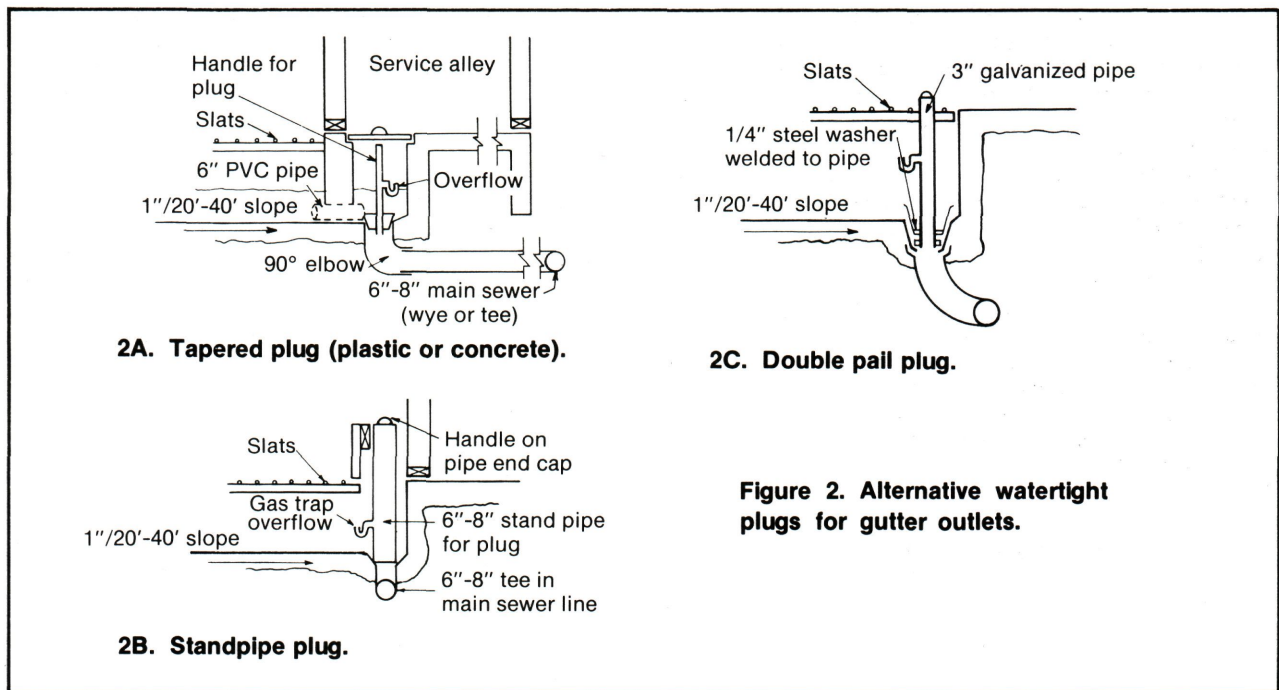

Figure 2. Alternative watertight plugs for gutter outlets.

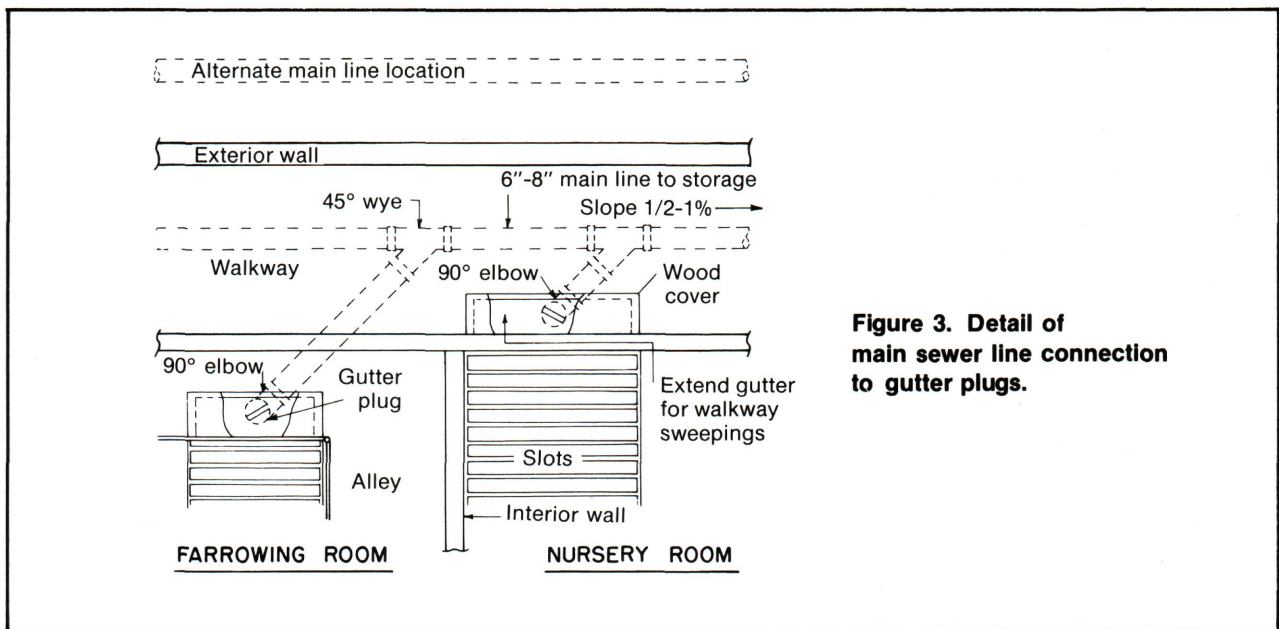

Figure 3. Detail of main sewer line connection to gutter plugs.

manure solids. This is critical if the flooring has only a small percentage of slotted or open area. The other alternative of washing the slope directly through the slotted flooring may splash too much water on the pigs. The crates in Figures 4A, 4B, and 4J generally are raised a minimum of 16 in. for "construction reasons." Crates elevated more than 12 in. normally require a portable ramp for the sow to get in and out.

Figure 4C shows the bottom of the rear slope starting about 18 in. from the rear of the crate. Manure solids accumulate mostly in the back 24 in. of the crate. The steeper 1-in. rise per 1 in. run slope helps in washing the solids into the gutter. This figure has a hovered front creep about 16 in. wide, which is a much easier add-on option with floor-level crates. The front creep can provide the warm environment needed for the pigs and away from the cool environment (70° F. or

less) desired for the sow. The pigs will not use the front creep when a "warm" flooring such as plastic is used in the sow area. The front creep also provides an easy access to the pigs that is away from the sow to prevent crushing.

The rear section of the gutter shown in Figure 4D is half of a large PVC pipe (generally 24-in. diameter) which collects most of the manure solids. The minimum slope of the front section toward the half pipe is 1 in. per foot, but 2 in. per foot is preferred.

The gutter shown in Figure 4E is similar to the gutters in Figure 4F but easier to construct. Generally the bottom of the V is 6 in. wide and the top 2 to 2 1/2 ft. The depth is about 12 in. A disadvantage of the V-shape is that it takes about three times as long as the Y-shape for the manure level to reach the 12-in. depth needed to drain it.

Figure 4F shows 2 precast concrete gutters back to back. The slope of the sides is about 1 in. rise per 1 in. run which is needed for self-cleaning. These 30-in. deep gutters have a bottom section 6 in. wide and 12 in. deep. The higher cost disadvantage of the gutters is offset by a shorter installation time.

Both cast-in-place gutters in Figures 4G and 4H have a square bottom to simplify construction. The one in Figure 4H requires a minimum of 1 in. per foot slope toward the gutter.

Concrete blocks can be used to elevate the crate (Fig. 4J) in order to install a gutter under it. The deep gutter is a 6- or 8-in. PVC pipe cut in half lengthwise. A disadvantage of this gutter is that it takes much more time to fill to the needed depth for good drainage than any of the other examples.

Examples shown in Figures 4A, 4B, and 4F can be purchased commercially whereas all the others need to be cast in place.

Nursery Pen Gravity Gutter Design

Six cross-sections for nursery pens are shown in Figure 5. Figures 5A and 5B adapt well for remodeled

barns where it is desirable to build above an existing floor. An advantage of Figure 5A over 5B is that the slope to the gutter is twice as steep, so cleaning is easier. The slope toward the gutter should be a minimum of 1 in. per foot, but 3-4 in. per foot is preferred. The gutter in Figure 5A has two 8-in. blocks for its bottom. It could also be constructed with a rounded instead of square bottom for slightly better cleaning. The legs of the pen frame should be 6 in. above the concrete block stands to allow access for cleaning the slopes. The nipple waterers should be located over the gutter to encourage pigs to drop manure there. The sides of the pen toward the alleys should be solid up to 16 in. high to keep the pigs' manure inside the pen (Fig. 5B). Prefabricated plastic is shown for the gutter and the sloping area next to it. The plastic slope needs to be supported with 2 x 4's unless sand fill is used under it for support (check manufacturer's recommendations).

Figure 5C shows a narrow pen (4 ft.) with a Y-shaped gutter underneath. For self-cleaning, the slope should be 1 in. rise per 3/4 in. run. This would require a 3 1/2 ft. depth to the bottom of the gutter, assuming it has a 12-in. deep bottom section. It is critical that the

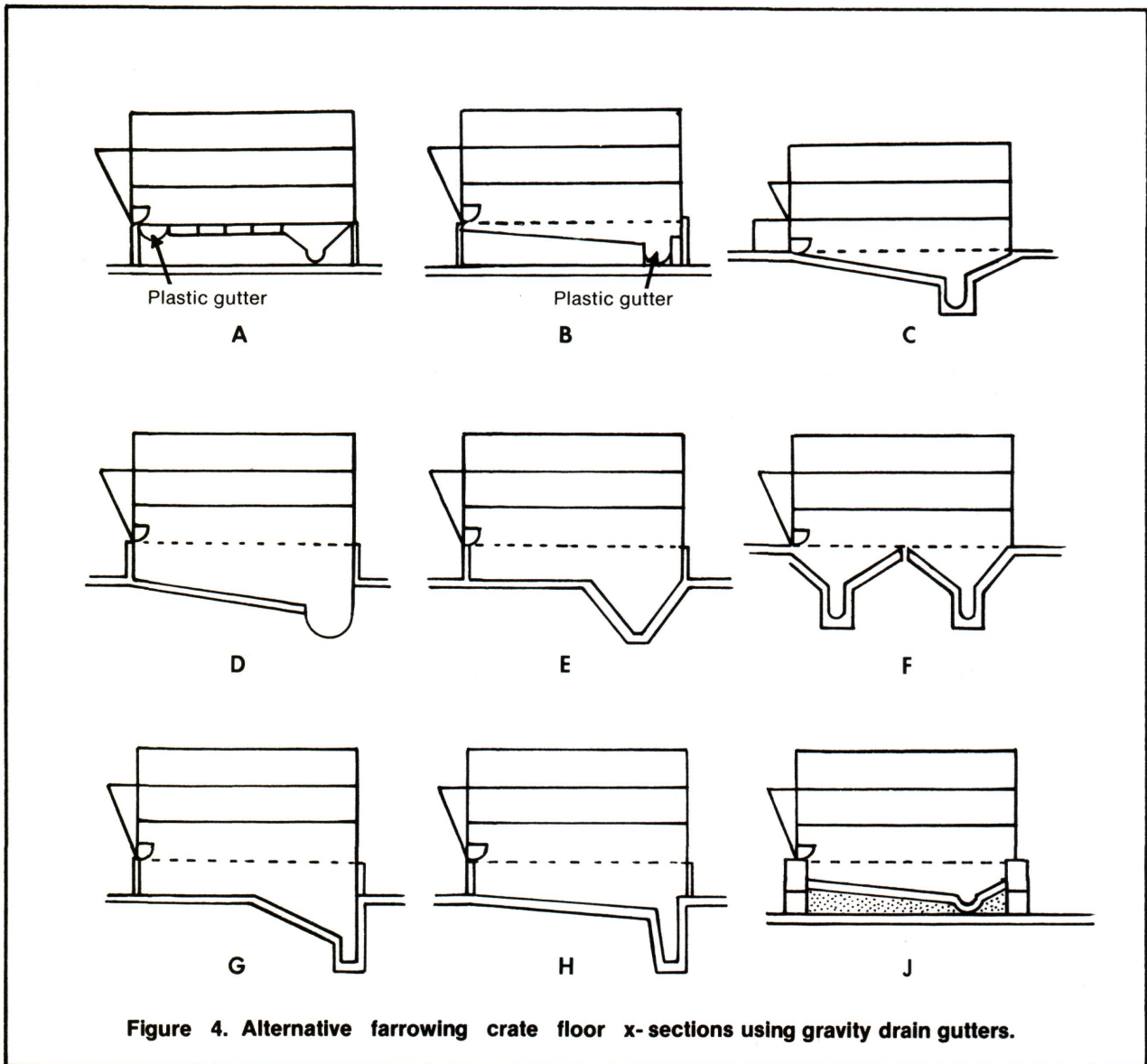

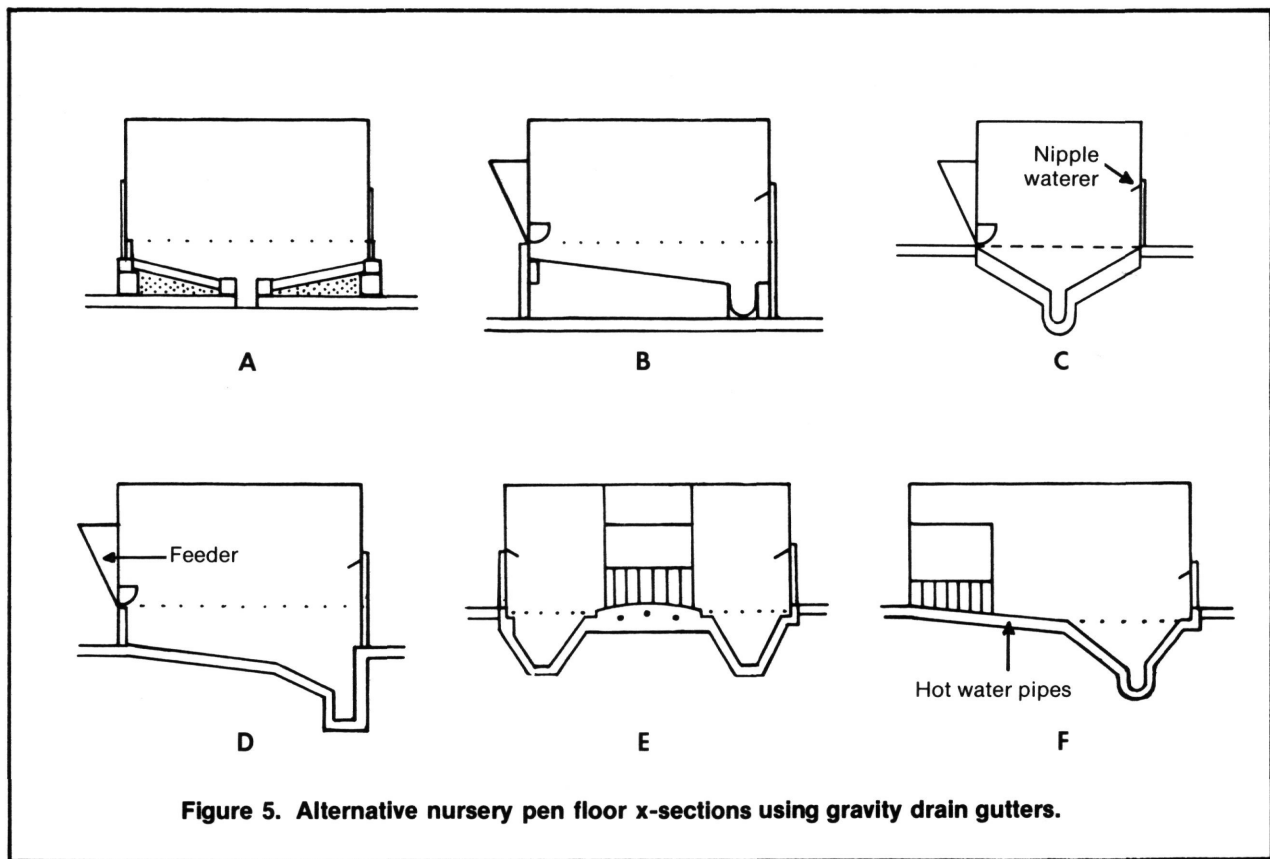

Figure 5. Alternative nursery pen floor x-sections using gravity drain gutters.

pen flooring be as open as possible when the pen is not elevated above the existing alley floor. Woven wire flooring is one type through which a floor beneath can be easily cleaned with a pressure washer.

The gutter shown in Figure 5D can be cast in place easier than the Y-shaped gutter in Figure 5C. A portion of the area nearest the gutter is sloped much steeper because most of the manure solids will fall through the floor at this end of the pen (usually the end opposite the feeder). The 6-in. square bottom is also easier to construct than the rounded bottom in Figure 5C.

The cross-sections in Figures 5E and 5F show partially slotted floors, whereas the other cross-sections show totally slotted floors. The partially slotted pens require slightly different design, management, and stocking rates. Figure 5E shows gutters on both sides of a heated concrete slab. The flooring over the gutters should be metal, not plastic; otherwise, pigs will lay on the "warm" plastic flooring instead of the heated slab. The concrete center section helps control the amount of feed wastage if the feeder is located in this section. The concrete center section generally is one-third of the pen length (typical pen length is 8-10 ft.). Observation of these systems indicates that pigs require 25% more area than on totally slotted floors. A 40-lb. pig requires 2 1/2 sq. ft. versus 2 sq. ft. on a totally slotted pen.

The example shown in Figure 5F is more difficult to manage than the others. At least 30% of the pen should be slotted. A heated concrete section is essential. Use a type of flooring over the gutter which is not warm to the touch to prompt pigs to dung in this area. Solid sides in the sleeping area are also essential for correct dunging habits. The gutter should have self-cleaning slopes because access to the slotted section is difficult.

The pigs should be allowed 3 sq. ft. per pig up to 40 lb. The pens should not be narrower than 4 ft.

Finishing Barn Gravity Gutter Design

Figure 6 shows a sloped solid floor pen with 1 or 2 gutters at the lower end of the pen. Floor slopes, pen partitions, and air flow patterns are critical considerations for keeping pigs resting on the upper end and dunging near the lower end. Dunging generally occurs in the open partition areas where the floor slope is steep (1 in. per foot recommended). It is important to have a 2-4 in. step down from the resting area to the dunging area. The dunging section should be a minimum of one-third of the pen length. The depth of the gutter in Figures 6A and 6B should be 24 in. A pipe guard over the gutter in Figures 6A and 6B may be installed to protect small pigs. Square gutters work as well as semicircular gutters in finishing units.

In Figure 6C, the floor between the gutters has a steep slope (1 in. per foot) for self-cleaning. This increases the effective slotted floor area. Another option is shown in Figure 6D. The manure is held in 2-ft.-deep gutters which are drained after the manure reaches a 12-in. depth. Disadvantages of this option include pit gas, produced because the gutters do not fill soon enough before they go anaerobic, and solids that settle out, requiring periodic cleanout. Advantages are less gas production and lower construction costs than deep pits. The slope design criteria which apply for gravity drain gutters also apply here. For these wider gutters, dividers should be placed lengthwise on the floor every 2 ft. across the gutter to reduce channeling and make cleaning easier. The dividers should be 6 in. high minimum and narrow to reduce solids buildup on them.

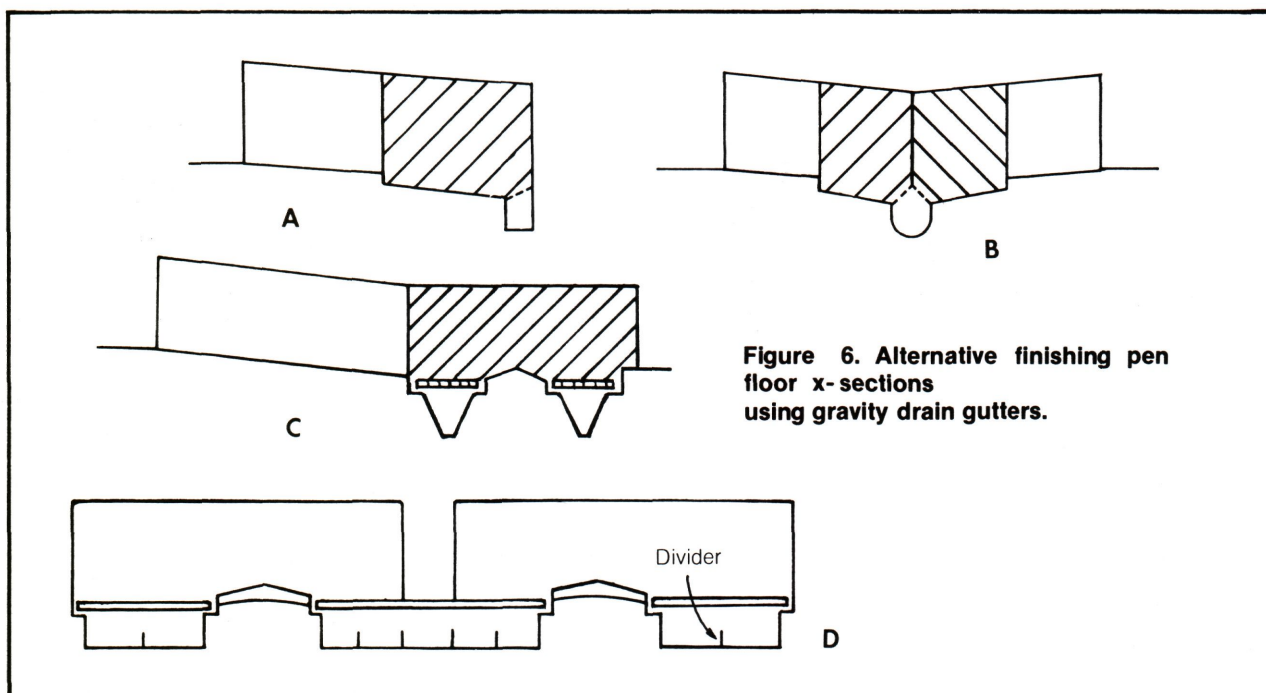

Figure 6. Alternative finishing pen floor x-sections using gravity drain gutters.

Manure Storage

Manure can be stored in a concrete or steel tank, earthen storage, or an earthen treatment lagoon (the latter two should be properly sealed). Tanks and earthen storages should be covered to minimize odors. A minimum of 60 days of storage time (180 days is preferred) is recommended. Check state regulations for minimum storage criteria. Refer to Pork Industry Handbook Fact Sheet 67, "Swine Waste Management Alternatives," for manure production per day and storage alternatives.

Draining or pumping manure into a storage under another barn will agitate that manure and release gases. Good pit ventilation is essential at the point of entry to handle the gases released into the barn when the existing liquid in storage is disturbed.

Manure Transfer Systems

If possible, design the system so that manure flows to the storage by gravity. The drain pipes from the plug should have a minimum of 6 in. diameter to prevent plugging. Eight-inch diameter is suggested for finishing barns and buildings where it is desired to drain all the gutters at one time. Slope the 6-inch and 8-inch pipe a minimum of 0.5% ($1/16$ in./ft.) to 1% ($1/8$ in./ft.) to achieve good cleaning velocities. The maximum distance between cleanouts in the drain pipe should be 300 ft. The storage inlet should be at least 3 ft. above the bottom since solids tend to settle out at the point where the manure enters the storage.

To obtain sufficient slope for gravity transfer of manure, it may be necessary to construct the barn floor on extra fill; otherwise, storage capacity is lost by not using all of the available height. Another alternative is a collection sump with a pump to lift the manure into the storage. Use a pump large enough to handle 1 1/2 inch diameter solids or use an air transfer system.

Gutter Construction

The gutters can be (1) assembled from commercially available prefabricated plastic, fiberglass, or precast

concrete sections; (2) made on the site from concrete by using commercially available forms; (3) constructed using home-built forms, or (4) a combination of the first three. The Y and V gutters are more costly to construct than the other shapes because of the steeper slopes.

Prefabricated and Precast Gutters

The fiberglass gutter sections are joined together by applying a liquid resin on an overlapping strip at the joint. The plastic gutter sections are joined together with a grip tape or caulking compound and bolts or channel brackets at the joints. The plastic gutter manufacturers have designed systems for below-floor and above-floor applications. Installation of below-floor plastic gutters requires inner bracing, to prevent the sand backfill or fresh concrete from pushing in the form, and weights or temporary bracing to keep the gutter in place. Precast concrete gutters are used in below-floor applications. Minimal excavation is needed with the precast concrete sections. They are set on a presloped footing and are stable without bracing or anchoring. The sections are mortared together to prevent leaks.

Forms to Construct Gutters

Commercial steel forms which are available for Y-gutters can be set in excavated trenches and anchored to the surrounding concrete floor with lag-bolts or weighted with sandbags. Concrete for the alleys is placed before the trench is excavated with a small backhoe. Commercial plywood forms can also be set in excavated trenches. They are temporarily braced to the roof trusses to prevent uplift. When gutter forms are used, the concrete is generally poured in one step and should be well vibrated to ensure a smooth finish.

Cast-in-Place Gutters

Generally, the bottom of cast-in-place concrete gutters is constructed first, using the excavated soil as the outside form (Fig. 7). An inner frame with short spacer blocks will form the inner wall. The wood grain should run vertical so blocks can be split and removed.

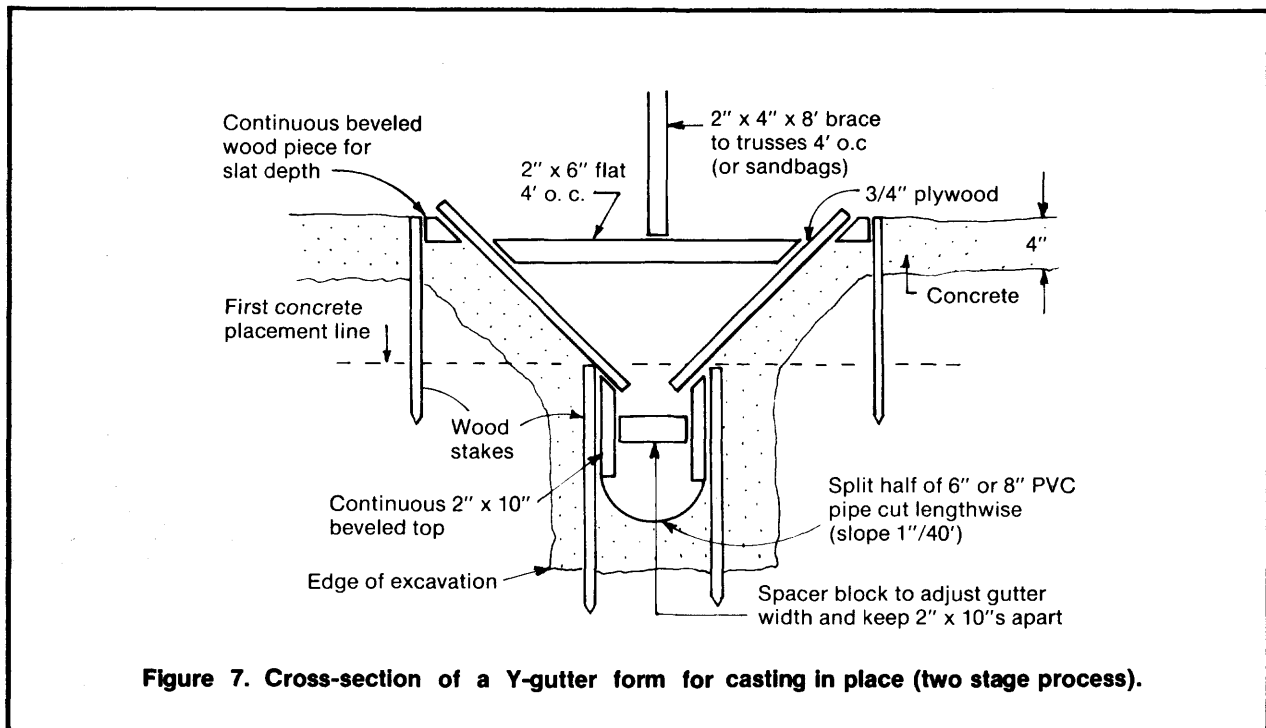

Figure 7. Cross-section of a Y-gutter form for casting in place (two stage process).

Fresh concrete should be vibrated to fill the space beneath the inner frame, to prevent water leakage from the gutter, and to provide a smooth surface. A semicircular bottom can be constructed by cutting a 6- or 8-in. PVC pipe in half lengthwise and nailing the half-pipe in the bottom of the inner frame.

Two methods have been used to form the steeper slope in the V or Y-shaped gutters. The **first** method utilizes reinforcing bars ($\frac{3}{8}$ in.) placed vertically every 4 ft. in the gutter and extended up the sideslope. The soil forms the sideslope for the underside of the concrete form. If the concrete is very stiff and concrete mesh is placed over the rebars (above the soil), then the concrete sideslope can be troweled in place. This is a time-consuming method, but it requires no forms.

The **second** method for the steep slope construction is to use existing soil or fill for the underside form. Stakes are driven as shown in Figure 7. A piece of wood is nailed to the top of the stakes to form a slat ledge (make it the same as the depth of the slats). Then, plywood is nailed to this piece of wood. The plywood is braced to the roof trusses or weighted to prevent uplift. After the concrete has set 1-2 hours, the plywood is taken off and the concrete steel troweled. Another way to give a quick, smooth finish with little troweling is to line the plywood with 4-6 mil polyethylene plastic or Masonite hardboard.

Foundation Insulation

When the gutters are placed next to an outside wall foundation, insulation is needed to minimize freezing in the gutters in cold climate areas. A minimum of 1 in. of a water-resistant foam insulation is recommended.

Remodeling

When remodeling requires new concrete on top of existing concrete, the minimum thickness of the new concrete must be 3 $\frac{1}{2}$ in. or 2 $\frac{1}{2}$ in. if reinforcing mesh is used. Use a mix of 7 bags of cement per cubic yard, and a small gravel size for the thinner concrete.

Management of the Gravity Gutter

Start-Up

A biological slime must form on the gutter sides and bottom to get good cleaning action when the gutter contents are emptied. This will naturally occur in 3-4 weeks. If solids remain in the upper end of the gutter during this initial period, they should be removed manually or hosed down.

Draining Gutter

It is important to have the gutter filled to at least a 12-in. depth before emptying the contents in order to move solids from the upper end. When replacing the plug or gate, wiggle it in the slot or seat to be sure the outlet is tightly closed. It should be drained at least every 4-5 days to ensure lower barn odor levels and good bottom scouring action in the gutter.

Water in Gutter

Adding 2 or more in. of water in the gutter after draining will facilitate better drainage of the gutter next time, particularly if it is greater than 40 ft. long. A waterer over each gutter ensures having extra dilution water in the gutter.

Safety

Do not enter collection sumps, or manure storages or hauling tanks, unless they have been and are being well ventilated. Also, do not enter these structures without a self-contained breathing apparatus or an air line. In addition, a body harness with a lifeline should be used, with two people standing by who are capable of lifting a person from the storage.

MICHIGAN STATE UNIVERSITY



COOPERATIVE
EXTENSION
SERVICE

MSU is an Affirmative Action/Equal Opportunity Institution. Cooperative Extension Service programs are open to all without regard to race, color, national origin, sex, or handicap.

Issued in furtherance of cooperative extension work in agriculture and home economics, acts of May 8, and June 30, 1914, in cooperation with the U.S. Department of Agriculture. Gordon E. Guyer, Director, Cooperative Extension Service, Michigan State University, E. Lansing, MI 48824.

This information is for educational purposes only. Reference to commercial products or trade names does not imply endorsement by the Cooperative Extension Service or bias against those not mentioned. This bulletin becomes public property upon publication and may be reprinted verbatim as a separate or within another publication with credit to MSU. Reprinting cannot be used to endorse or advertise a commercial product or company.

New—2M—11:84,KMF—CP, Price 45c