



pork industry handbook

COOPERATIVE EXTENSION SERVICE • MICHIGAN STATE UNIVERSITY

Remodeling Ideas For Farrowing Facilities

Authors

Larry D. Jacobson, University of Minnesota
Robert D. Fritschen, University of Nebraska
J. Pat Murphy, Kansas State University

Reviewers

Frank H. Hedden, Clemson University
Dennis Liptrap, University of Kentucky

Existing farmstead buildings, such as dairy barns, can sometimes be remodeled into successful farrowing facilities. Other times, however, the only benefit of remodeling is saving the cost of the building "shell," a relatively small percentage of the total construction cost. Therefore, all available options should be analyzed carefully before proceeding with a remodeling project. This fact sheet first discusses the decision factors in remodeling and then how one should approach such a task.

Decision Factors

Location

If an existing facility is not in or near an area suitable for a new facility, then the old unit should not be remodeled. Criteria for proper site selection include: correct distance and direction from farm home, location near existing hog facilities; space for future expansion, ease of materials (animals, feed, and waste) handling, proper drainage, reasonable access to utilities, and some degree of security. Rarely can all of these guidelines be strictly found when considering locations. But if the site is, for instance, adjacent to and downwind from the house or on the opposite side of the farmstead from the other hog buildings, the decision to remodel *definitely* should be reconsidered.

Structural Soundness

Obviously, the structural condition of the existing facility is important. The building should be sound from the foundation to the roof. If work is needed to solve major problems such as a cracked foundation, a sagging roof, a leaning wall, or a series of rotten ceiling joists, then the facility should not be remodeled. Only a minimum amount of exterior work, such as shingling and painting, can be tolerated in a proposed remodeled building.

Physical Size

First determine the space required for the proposed farrowing operation. Then, if the building is of sufficient size, consider it to be a candidate for remodeling. Do not reduce original size requirements to fit an existing structure; in-

stead, build a new unit. If a building is too large, a partition wall can be added to accommodate the proposed farrowing unit.

Pros and Cons

Before starting a remodeling project, list the advantages and disadvantages of the proposed remodeled structure. Consider the location, the structural soundness, the size and other criteria in the list. Economic considerations are important, but remember that most people *underestimate* the cost of materials and labor required for remodeling. If remodeling expenditures exceed 50% of the cost of a new unit, do not remodel. The time spent listing the pros and cons can often save a great deal of money, time and disappointment.

Design Factors

Layout

After deciding to remodel, the first item to consider is the layout. The arrangement of the farrowing crates or pens depends on all of the following: inside dimensions of the facility; condition and contour of the floor; location of support posts, gutters, mangers, partitions; and other obstructions. Most dairy barns can accommodate up to 3 rows of farrowing crates or 2 rows of farrowing pens (Figure 1). Other facilities (Figure 2) can tolerate only 2 rows of crates and a single row of pens. Narrower buildings can use the arrangement given in Figure 3 which allows for 2 rows of crates with narrow side alleys used for feeding sows and handling piglets. As a general rule, it is preferable to have crates and pens run the length of the building rather than across the width. However, partitions may be added to a large facility, as shown in Figure 4, to allow for separate farrowing rooms with a common hallway. If farrowing crates are desired, the "raised" variety (Figure 5) adapts to most types of existing floors; whereas, considerable concrete work is often required if crates are placed on the existing floor. In addition, raised crates can be purchased pre-assembled which speeds up the remodeling process. A disadvantage includes difficulty getting sows in and out

Cooperative Extension Service Programs are open to all without regard to race, color, national origin, or sex. Issued in furtherance of cooperative extension work in agriculture and home economics, acts of May 8, and June 30, 1914, in cooperation with the U.S. Department of Agriculture. Gordon E. Guyer, Director, Cooperative Extension Service, Michigan State University, E. Lansing, MI 48824.

1P-5M-6:81-UP, Price 20 cents. Single copy free to Michigan residents.

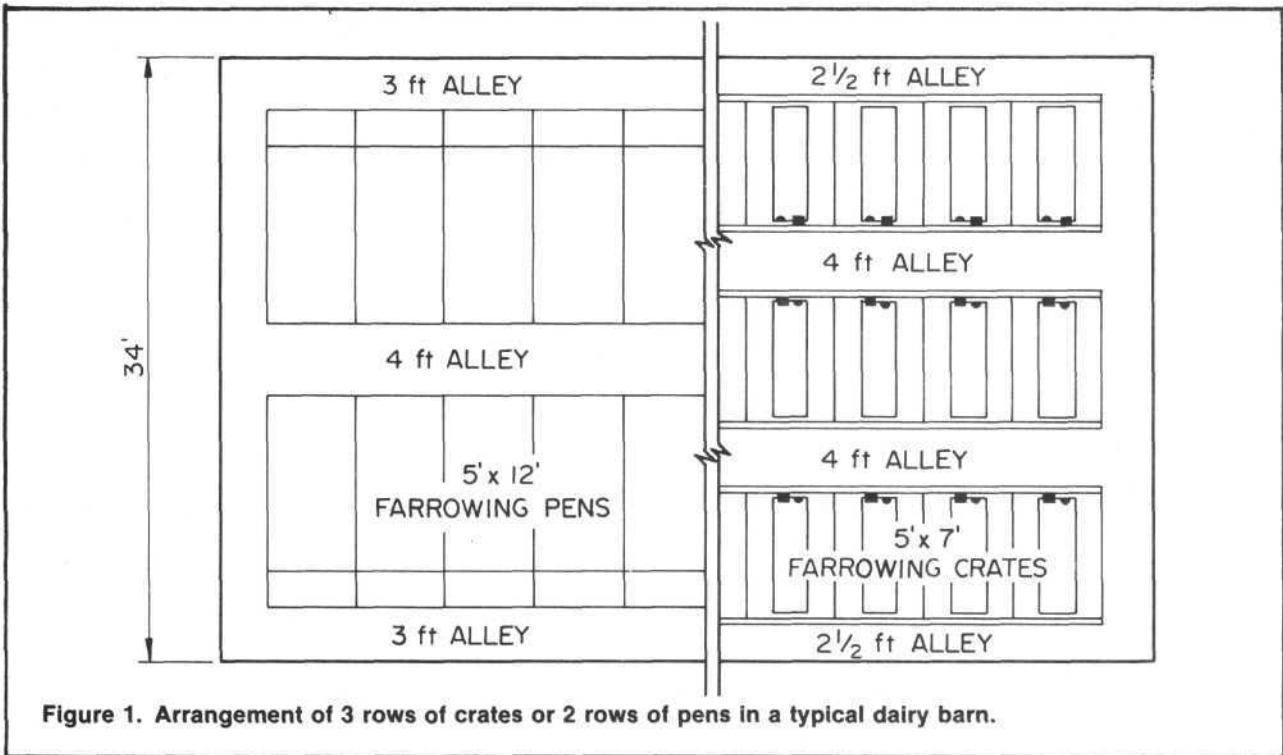

Figure 1. Arrangement of 3 rows of crates or 2 rows of pens in a typical dairy barn.

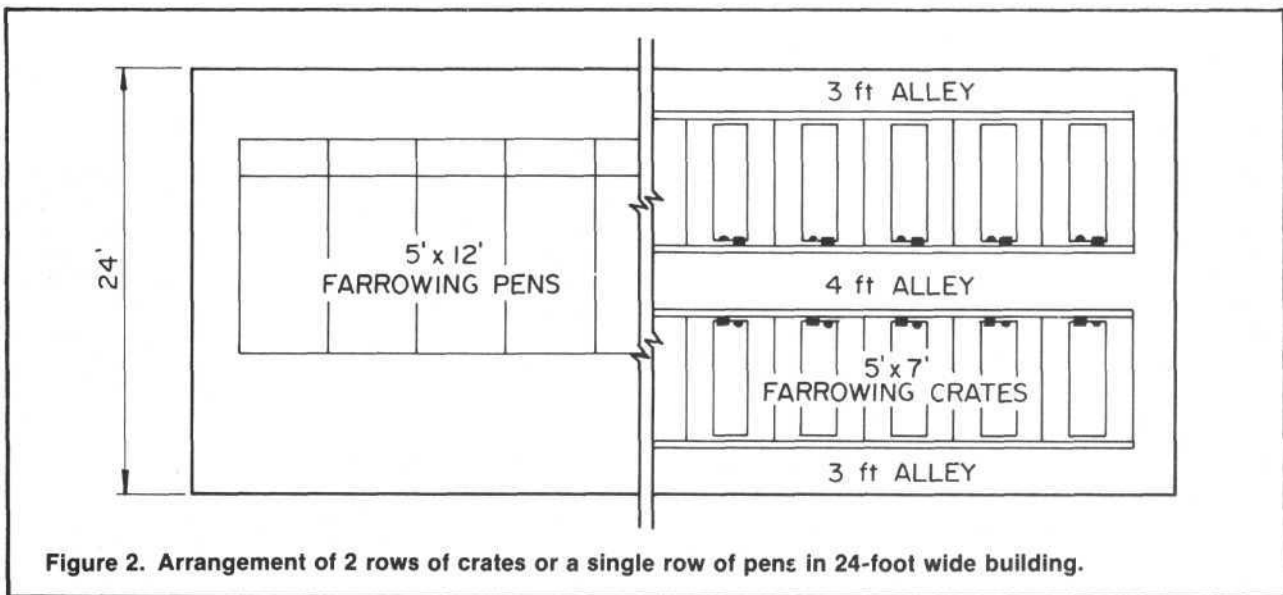

Figure 2. Arrangement of 2 rows of crates or a single row of pens in 24-foot wide building.

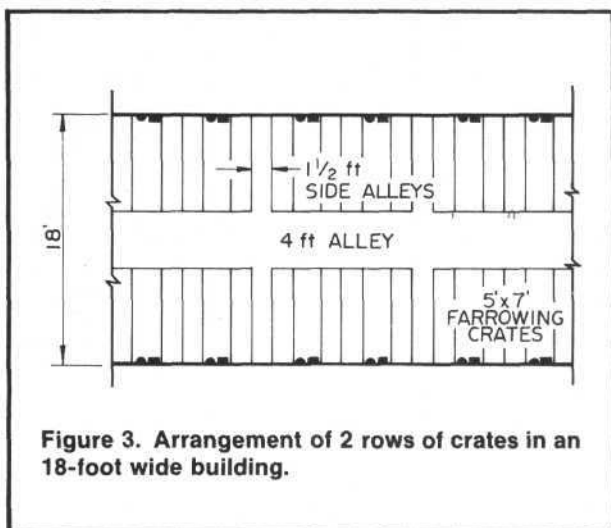

Figure 3. Arrangement of 2 rows of crates in an 18-foot wide building.

of crates from a lower alley. However, this problem can be solved by using a homemade movable ramp.

The layout of farrowing crates or pens in a remodeled facility is a compromise between how easily manure, feed, and animals can be handled and the maximum use of the available space. It is generally assumed that more labor per sow is required in a remodeled facility than in a new facility. Many times producers try to squeeze in an extra stall or two which makes their labor requirements excessively high compared to those where "extra" stalls were left out.

Manure Handling

The method of manure handling is also an important consideration in the remodeled farrowing facility. Manure can be handled as a solid or a liquid. When handled as a solid, some type of bedding is required. Most liquid systems have storage facilities (capacity for 6 mos. use), which adds to the initial investment.

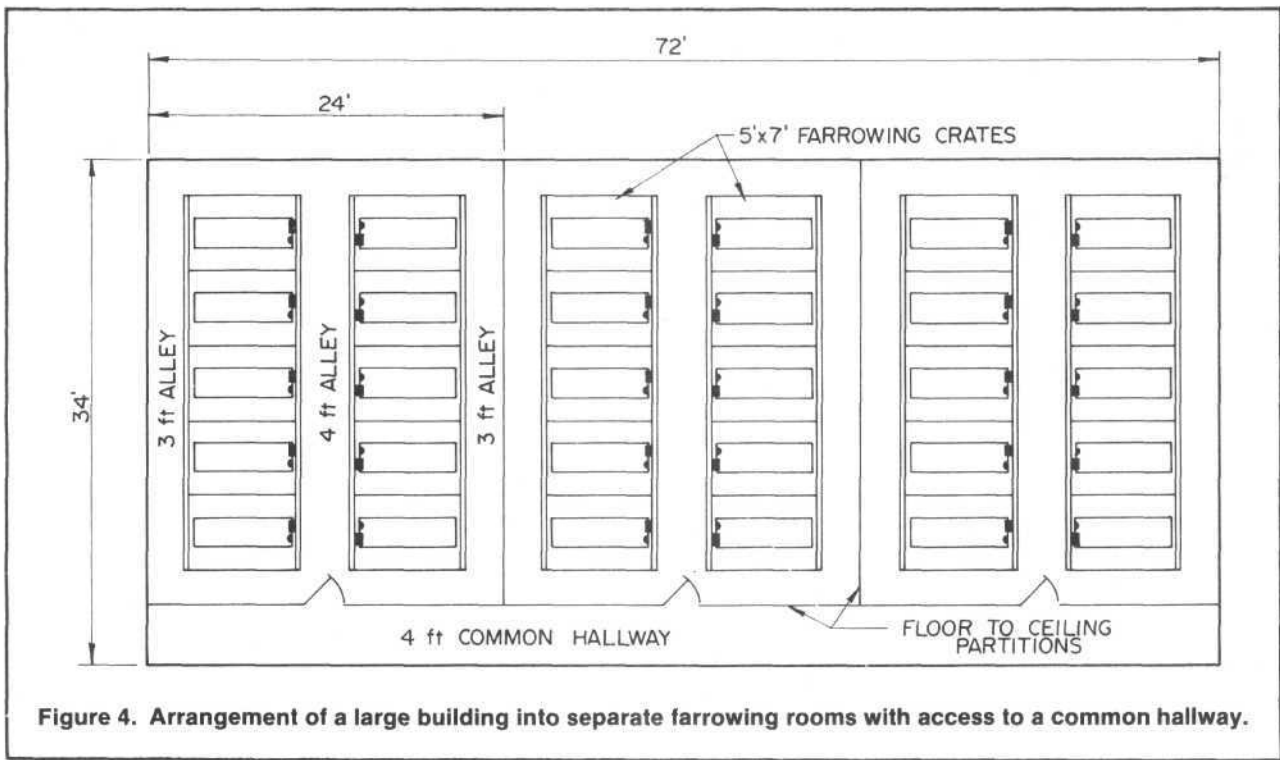

Figure 4. Arrangement of a large building into separate farrowing rooms with access to a common hallway.

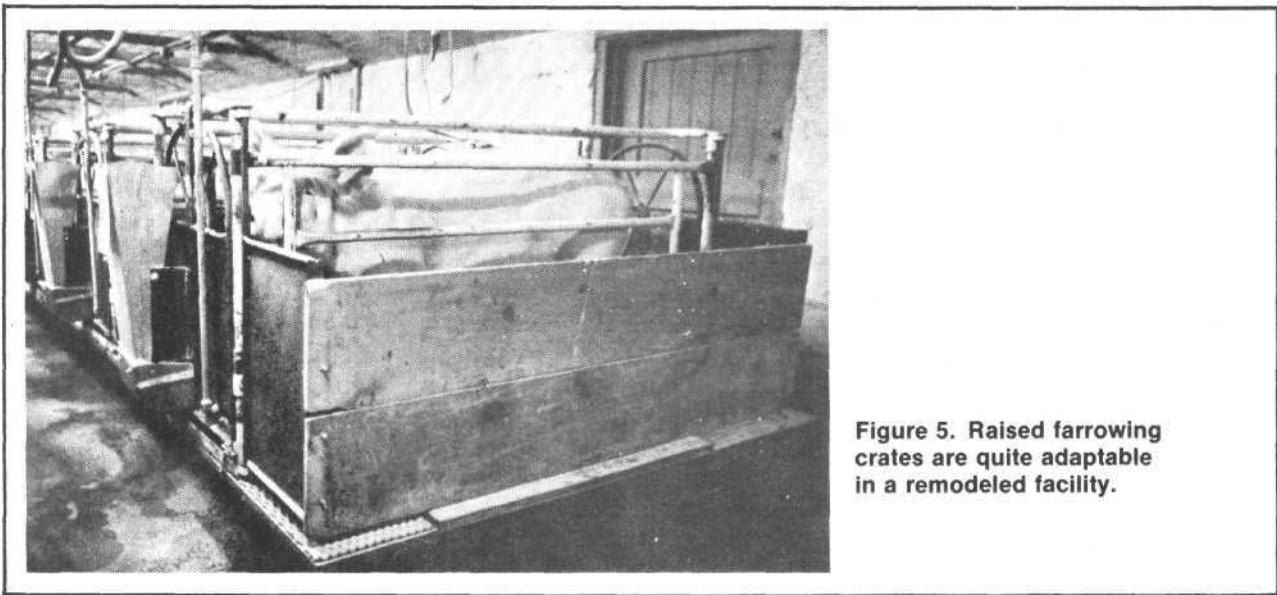

Figure 5. Raised farrowing crates are quite adaptable in a remodeled facility.

Since a relatively small amount of manure is generated in the farrowing barn, it may be removed by hand scraping. A requirement of this method is to have sloped floors so that separation of solids and liquids occurs. As the lowest investment, highest labor system, it puts very few constraints on crate or pen location, so space efficiency of the remodeled unit is high. Some solid manure systems use gutters and barn cleaners (Figure 6). Often the existing equipment in an old dairy barn can be used directly. Labor is significantly reduced compared to hand scraping, but daily or frequent hauling is still required.

Liquid manure systems are high-investment and low-labor. Deep pits are used frequently in new construction, but are not recommended for remodeling because of the time, labor, and expense involved in digging a pit inside of an existing building. An easily adapted liquid system in a remodeled facility is the gravity drain system. This technique drains manure to an outside storage unit without the aid of a flush tank. A storage unit is built outside of the building and at an elevation which is below its gradeline; other-

wise, a sump and pump are needed. The gravity-drain gutters can be Y-shaped or rectangular shaped (Figure 7). The width of a flat-bottom gutter should be 2 feet or less so that channels are not formed when the manure is emptied. If wider gutters are necessary, flow straighteners like that shown in Figure 7 should be used. The bottoms of the gutters need a slight slope ($1''/25'$) to one end where a 6 in. diameter drain is located (Figure 8). Manure is removed by periodically "pulling the plug" and letting the manure drain into the storage pit. A vent should be placed on the storage unit so that "back pressure" does not restrict the draining action. After cleanout, water should be added until the bottom of the gutter is covered. This additional water avoids the problem of manure drying or "sticking" to the bottom. It is generally recommended that the manure be removed at least once a week.

Insulation

The walls and ceilings of the facility should be insulated to prevent the formation of condensation on the interior



Figure 6. Traditional gutter cleaners work well in a solid manure system.

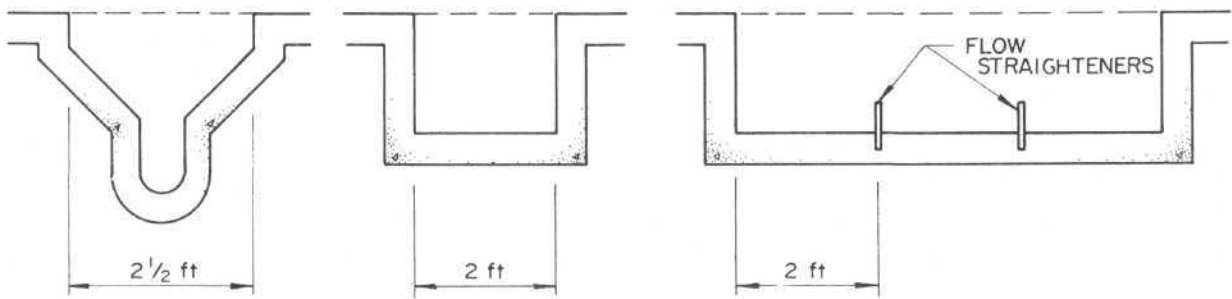

Figure 7. Y or rectangular-shaped gutters used in gravity-drain liquid manure systems.

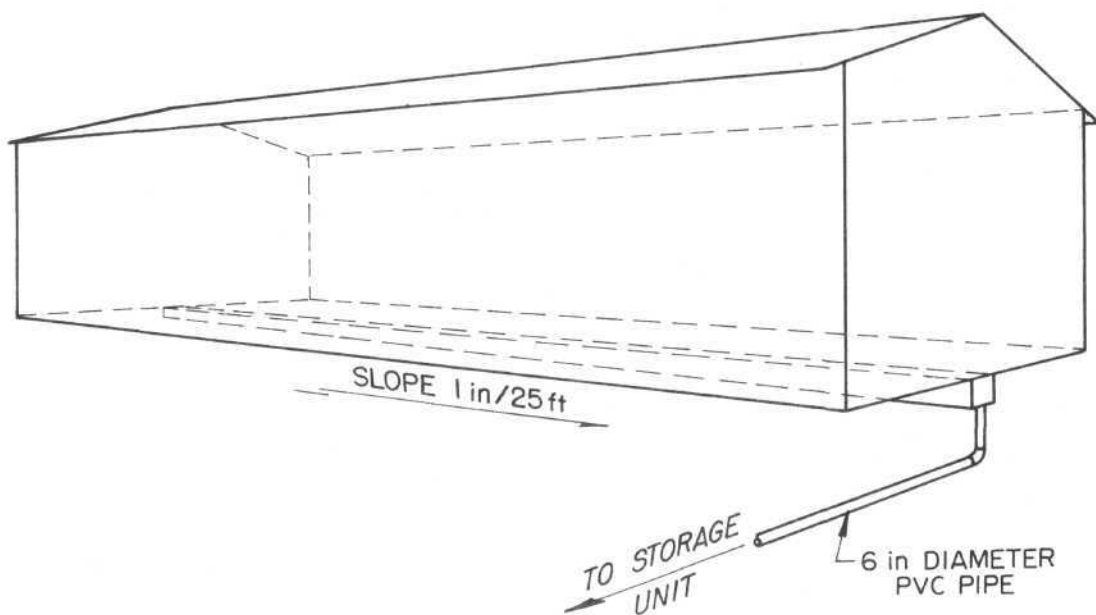

Figure 8. Slope of gutters in a gravity-drain system.

surfaces. Insulation also reduces heat loss in the winter and heat gain in the summer. A 4 or 6 mil (0.004 or 0.006 in.) polyethylene vapor barrier should always be placed on the warm side of the insulation to protect it from moisture damage.

A horizontal ceiling should be present in a remodeled farrowing building. This plan allows for either a hayloft or an attic space from which incoming ventilation air may be taken. Several feet of old hay or several tiers of baled hay in a hayloft of an old barn is sufficient insulation. Other facilities should have 6-8 in. of fill insulation (R-value of at least 23) in the ceiling. Place a vapor barrier on the warm side of the insulation and, if possible, underneath the hay.

There are generally 3 basic types of existing walls in facilities. The first is where either 2 x 4 or 2 x 6 studs are used and left exposed. Insulation of this wall is accomplished very simply by fitting 3½ in. (R-value = 11) or 6 in. (R-value = 19) fiberglass blankets between the studs. A vapor barrier is then put over the insulation, and plywood or other rigid material is nailed to the studs to form a protective covering.

Another common type wall uses unexposed studs. For this case, it is best to remove the inside boards and to insulate the spaces with fiberglass blankets as suggested earlier. Blowing in loose-fill cellulose or foam-in-place urea formaldehyde is possible, but settling and shrinkage are disadvantages.

The remaining type of wall is block or tile. The insulation value of such walls is very low (R-value of 0.5-2). One can insulate these walls by vertically stripping 2 x 2's 2 ft. on center against the wall and placing sheets of 1½ in. thick foam-type insulation between the studs. Again, a polyethylene vapor barrier should be applied on the warm side of the insulation and 5/8-in. plywood, fire-rated 1/2-in. plywood, or some other acceptable material, be placed on the wall for fire protection. Normally placement is on the inside, but the same procedure can be done on the outside surface. Either method gives an insulation value for the wall (R-value = 9) which will prevent condensation under most conditions. If a higher R-value is desired (R-value = 14),

one may strip the walls with 2 x 4's instead of 2 x 2's and use 3½ in. fiberglass blankets instead of the foam insulation.

Ventilation

It is best to approach the ventilation in a remodeled facility as you would in a new unit. Too often producers try to modify an inadequate existing system which causes more problems than it solves.

Fan capacities should be chosen based on the recommended ventilation rates in cubic feet per minute, cfm, at 1/8 in. static pressure (see Table 1). Fans should be lo-

Table 1. Recommended ventilation rates or fan capacities for farrow facilities.

Continuous winter	Fall	Summer
cfm/sow and litter		
20	(+60) 80	(+130) 210

cated where they do not face prevailing winds and should be mounted in existing windows. Make sure that the minimum fan runs on a *continuous* basis and that it is rated at 1/8 in. static pressure. This fan can have a duct built over it so that air is removed from near the floor (Figure 9). This action conserves heat and, by adjusting the sliding damper, airflow of a larger fan can be throttled down to the correct level. The other fans would be controlled by thermostats and operated in a stepwise fashion.

Fans determine the amount of air moved, but the distribution of air inside the facility is determined by the size and location of the air inlets. During the winter, provide 18 in. of 1-in. wide slot for every 100 cfm of fall and spring fan capacity. This inlet area can be provided by cutting 1-in. wide slots and removing air from the attic space (see Figures 10 and 11). An alternative is to drill 2-in. diameter holes, as shown in Figure 12. Six 2-in. diameter holes spaced 3-in. on center is approximately the same area as 18 in. of a 1-in.

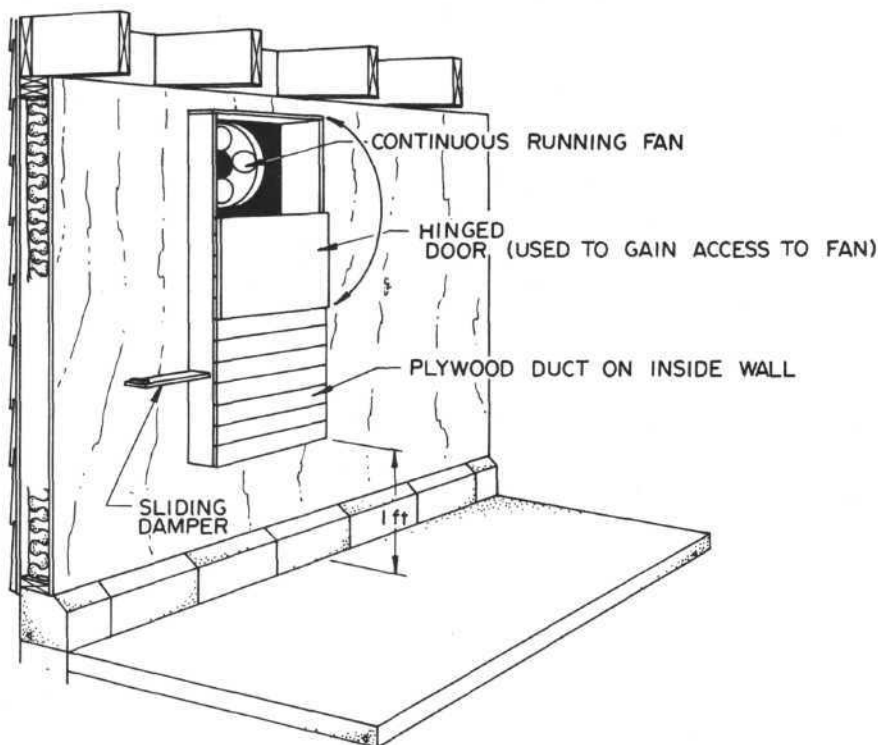

Figure 9. Plywood duct built around the continuously running fan to draw air from near the floor and throttle down a large fan.

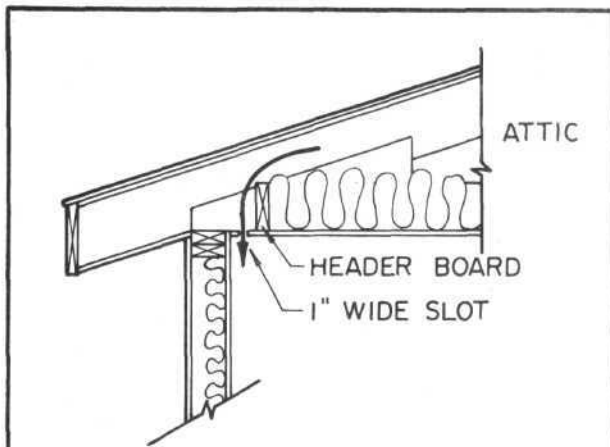

Figure 10. Detail of a 1-inch wide slot cut in the ceiling along both walls.

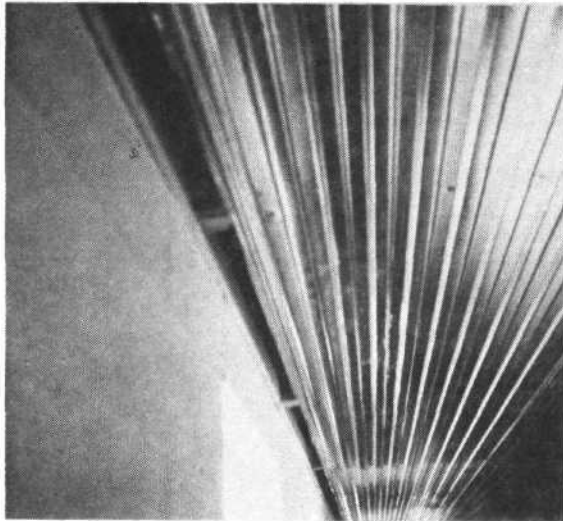

Figure 11. A continuous 1-inch wide slot in a farrowing unit.

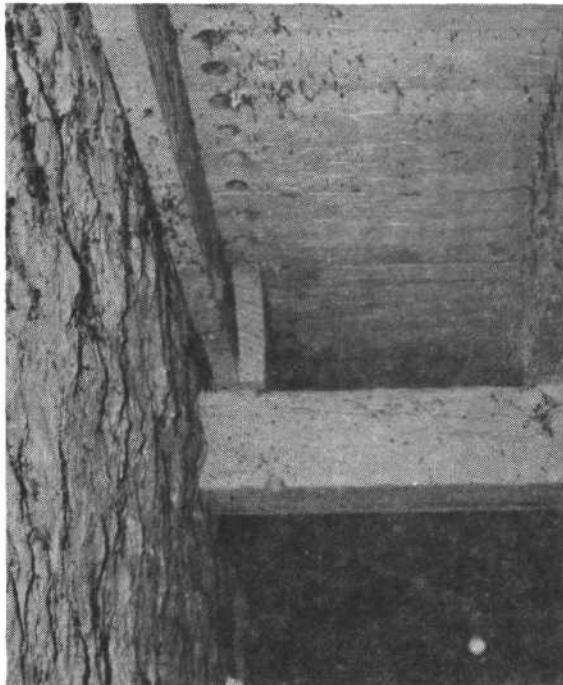

Figure 12. Two-inch diameter holes drilled in a ceiling to approximate a slot inlet.

wide slot. Sufficient air distribution will result if the slots or holes are evenly spaced along both walls. One must place header boards in the attic to protect inlets from plugging with insulation or hay. Additional inlet area is required for warm weather operation. As before, provide an 18-in. long 1-in. wide slot for every 100 cfm of added summer fan capacity. This additional inlet area may be located in the ceiling, adjacent to the winter inlets, or it can be provided by outside ventilation doors (old converted windows) or eave openings. All other windows should be permanently closed and covered with insulation. The outside inlets should be located on the north or east sides since this is the coolest air available.

Management of these inlets can be done automatically with static pressure-sensitive devices or manually. Generally, only two basic settings are necessary; one for winter and one for warm temperature conditions. Any time that inlets are placed in the ceiling, louvers or vents must be provided in the attic to allow air to enter that space. Louver area should be 1½ times larger than the ceiling inlet area.

Heating

A remodeled farrowing building will generally require more supplemental heat than a new facility. For cold climates, use 5,000 BTU per sow to determine heater size and 3,000 BTU per sow for milder climates. Hot air furnaces are often used to provide this supplemental heat. To obtain even heating, a plywood distribution duct like that shown in Figure 13 works well. Caution should be used in the thermostat settings of the fans and the heater so that they do not conflict. The continuous running (minimum) fan should be the only one operating when the heater comes on. The thermostat on the next larger fan should be set high enough so it does not turn on while the heater is operating. Besides maintaining a proper air temperature (supplemental heat), creep heat is necessary for maintaining warm surface temperatures for baby piglets.

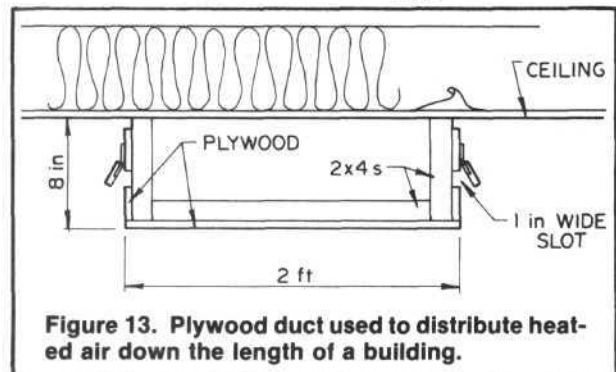

Figure 13. Plywood duct used to distribute heated air down the length of a building.

Summary

Remodeling of existing farmstead buildings into farrowing facilities can sometimes be a feasible approach to starting or expanding a hog operation. However, the building under consideration must meet certain cost, location, and upkeep criteria to qualify for remodeling. Should these criteria not be met, then the decision to remodel that building should definitely be reconsidered.

The following PIH fact sheets contain information related to remodeling and should be consulted before entering into construction.

- PIH-10 Swine Farrowing Units
- PIH-32 Building Materials and Equipment for Swine Facilities
- PIH-57 Supplemental Heat for Swine
- PIH-60 Mechanical Ventilation of Swine Buildings

Reference to products in this publication is not intended to be an endorsement to the exclusion of others which may be similar. Persons using such products assume responsibility for their use in accordance with the current directions of the manufacturer.