

Extension Bulletin E-1501
FILE: 19.35
June 1981

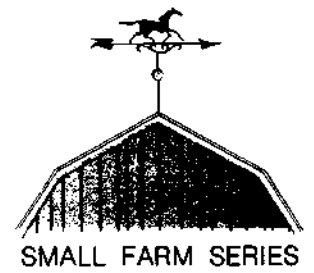

Housing Your Sheep

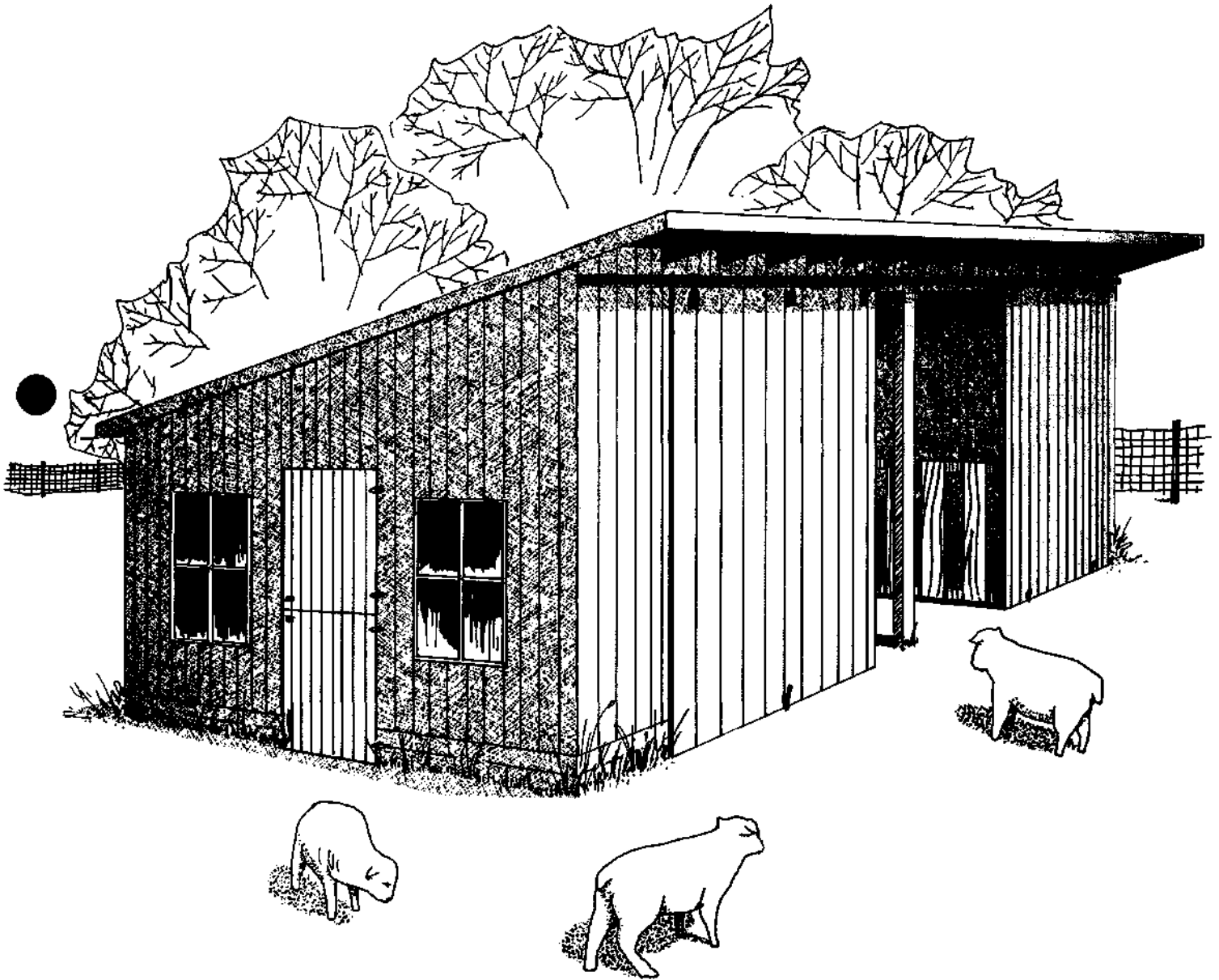

Housing Your Sheep

By Marvin Heft*

Extension Agricultural Agent, Allegan County

Small flocks of sheep are becoming increasingly popular in Michigan. This interest is particularly strong among people living on small acreages. Sheep keep weeds under control on nonlawn areas and provide a source of meat, fiber and income. Sheep are also excellent animals for youth in 4-H programs.

Sheep in most cases require some type of housing. Perhaps an existing building can be adapted or a new one built to fit the needs of the sheep.

There are four factors to consider when selecting sheep housing. The first two have to do with the sheep and their needs. The other two have to do with you and your environment.

Sheep need an environment that will keep them healthy. Furthermore, they need a certain amount of space for safety and comfort. You, as an owner, need an environmental system that is acceptable to you. We all have an idea of what we can accept.

Some people leave their sheep outside all winter; others want their sheep inside a closed building. Most use an open type of building. All are acceptable, within limits, to sheep.

Your neighbors could be your biggest problem in deciding on an acceptable environment for your sheep. Will the type of environment you choose be acceptable to them? Will they call the authorities if you keep your sheep outdoors during the worst part of our Michigan winters? Some people, sheep owners included, believe that sheep must be inside during the winter. If they are your neighbors, you could have problems with them.

This bulletin does not provide all the specific construction details needed to build sheep housing. It provides basic concepts and principles to help you determine the sheep housing that will best fit your needs.

Before You Buy, Build or Remodel

Before you start pounding nails, consider the following questions:

- Can you keep sheep at your location? Check local zoning regulations. Does your proposed building meet local building codes?
- Is the site well-drained? Build on a well-drained site. A building on wet soil will always be damp inside.
- Is the site easily accessible at all times to care for the animals and to bring feed in? It should be.
- How are you going to handle the manure and control flies? Long-time summer storage could lead to fly problems.
- Does the site have sufficient room for a season's hay storage, or will you have to bring in hay weekly or monthly?
- Will your water system supply adequate water for your sheep and meet your peak household needs? The same holds true for your electrical system.
- Have you thought about the accessibility of fire equipment to the building in case of a fire?
- Does your planning include adequate locks and latches on doors and gates?

*The author expresses special thanks to William Bickert, Extension Agricultural Engineer; Duane Girbach, County Extension Director, Livingston County; and Joseph Ames, Extension Agri-

cultural Agent, Washtenaw County, for reviewing this bulletin and making suggestions.

Sources of Information

Several sources of information and plans can help you design your sheep housing.

The Cooperative Extension Service, serving all counties of Michigan, has several sources of assistance for you. They have plans for sheep barns, a publication, "Sheep Handbook, Housing & Equipment" (MWPS-3) that gives specific details on construction of many of the needs of a sheep barn. Extension Bulletin E-1058, Sheep Buildings & Equipment, is a catalog of plans. There is a charge for the handbook and for some of the plans. Most Extension Agricultural Agents can assist you in developing a plan to fit your needs.

Many lumber dealers have plans available from design services or lumber associations. A few have planning services. Some building contractors can assist in planning a sheep barn.

One important point to remember: make use of trained people in designing your sheep housing. The building must meet your needs and the needs of the sheep.

Remodel an Existing Building

Remodeling is probably the biggest problem facing a sheep owner with a building on his/her property. Remodeling is all right if the building can economically be converted to proper sheep housing.

The first thing to look at is the condition of the building. Is it worth remodeling? Are the frame and roof in good condition? Are the building's footings adequate? What is the condition of the existing floor? Is there at least an 8-foot ceiling height? Can the existing building be ventilated properly? Is the location desirable for you?

In short, will the remodeled building provide sheep housing that will satisfy you at a cost that is equal to, or less than, the cost of a new building?

Remember, old basement barns are hard to ventilate properly. Before proceeding, make sure the ventilation system is properly designed.

How Much Shelter Do Sheep Need?

The minimum requirement for sheep in most of Michigan is no housing. Housing is not necessary for most sheep if there is adequate shade from the summer sun and windbreak against winter winds. Most farm woodlots can supply both of these basic requirements. However, use of the woodlot for this purpose might not be compatible with your idea of good woodlot management. Furthermore, the woodlot might not be in a convenient place for you to care for your sheep. Lambing during the winter months will require shelter that is handy.

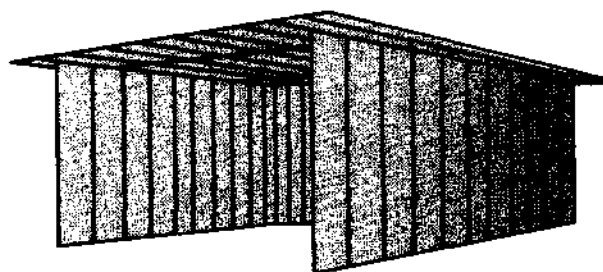

Fig. 1—Typical open housing.

Types of Sheep Housing

A basic requirement for sheep housing is that it be free from excessive moisture and drafts. The cold temperatures experienced in Michigan are only a secondary consideration. Sheep, as well as other animals, can tolerate very cold temperatures, if they can get out of the wind. Excess moisture in sheep buildings is responsible for many sheep respiratory problems during winter months. Ideally, the relative humidity should be between 50 and 80 percent.

There are three basic types of sheep housing:

Open Housing—One or more sides of the building are left open (Fig. 1). Sheep are allowed to move in and out of the building at all times. The inside temperature is about the same as the outside temperature. This is one form of cold housing, but not included in the cold housing definition.

Cold Housing—Building is enclosed and the inside temperature fluctuates with the outside temperature. The inside temperature can be slightly warmer. Ventilation is required to remove excess moisture from the building. Normally, sheep are not penned inside the building.

Warm Housing—Building is enclosed and the temperature is maintained between 45°F and 65°F. Ventilation is required to remove excess moisture from the building. Insulation is recommended to minimize the required heat needed to maintain desired temperature. **This type of sheep housing is not recommended.** Warm temperatures cause poor wool quality.

Of the three types, open housing is by far the most popular in Michigan.

When using an existing building as open housing, doors and windows on the side away from the prevailing (generally westerly) winds are generally left open.

Burlap covering the open windows will prevent drafts and normally provide enough ventilation to remove excess moisture if there are openings on the opposite side. Closing doors (during periods of

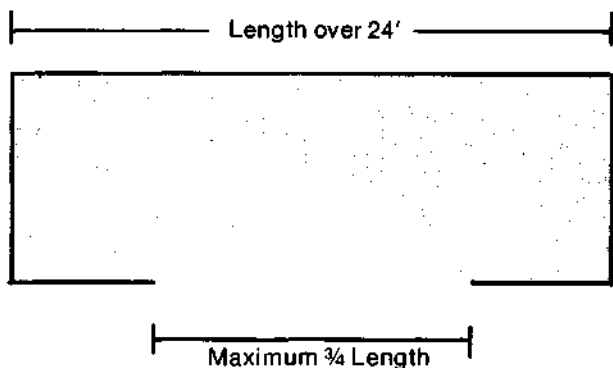

Fig. 2—Maximum opening for open-housing buildings over 24 feet long.

adverse weather) converts this type of open housing into cold housing. This is often done prior to shearing to make sure that the wool is dry at shearing time.

A new open-housing building can be a simple roof with two or more sides, located on a dry site, providing between 12 and 16 square feet per ewe and lambs. If you will be having only feeder lambs, plan on 6 to 8 square feet per lamb. Buildings over 24 feet in length need a minimum of three sides. The fourth side can be closed up to one-quarter of the length (Fig. 2).

At lambing time, you may need heat for short periods. A form of spot heat will provide the needed heat over the lambing pens. For more information, see section on heat in open and closed housing.

Building Types and Requirements

Roof Styles

A wide variety of possibilities exist in sheep housing styles (Fig. 3). Most common is the gable roof. The aesthetics of the building has a great bearing on your final decision. Recent developments in metal siding have improved the looks of the clear-span, post-frame building.

The gambrel roof is often used where hay and straw are desired overhead and where appearance is a consideration.

In the clear-span building, hay and straw storage is on one end of the building. Often the building is made long enough to store lawn and garden equipment and other tools.

Size of Building

The amount of space needed in your sheep building depends upon the number of sheep to be housed. You will also need room to store feed, medicines and room for lambing pens.

Plan on 12 to 16 square feet for each ewe and her lambs. If you are only housing feeder lambs, you will need 6 to 8 square feet per lamb.

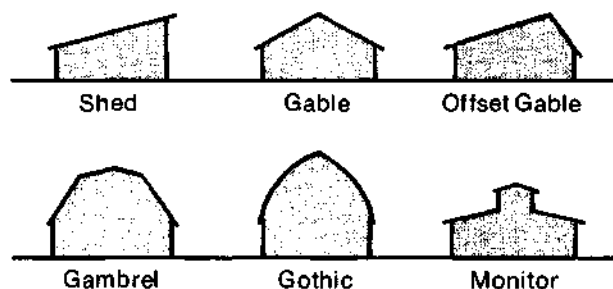

Fig. 3—Some common roof lines.

Plan on having room for one lambing pen for every 7 to 10 ewes. The lambing pen can be a minimum of 4 by 4 feet in size.

Storage

You will need storage space for hay, grain and straw—20 cubic feet per ewe to store one month's hay supply and 20 cubic feet to store one month's straw supply. The grain storage size varies according to the type of sheep you will be housing. The ewe will require 2 cubic feet for one month's supply. The feeder lamb needs 4 cubic feet to store one month's supply.

If there is a small silo on your property, you may be able to use it to store feed in the form of haylage or corn silage. Check with your Extension Agent to see if this is practical in your case. In most cases, this will not be practical.

The supply room can be as small as a 4- by 6-foot room. A larger room may be more practical.

Space Requirement Calculations

$$\text{Floor Space: Ewes, No. Head} \times 12 \text{ to } 15 \text{ sq. ft.} =$$

$$\text{Feeder Lambs, No. Head} \times 6 \text{ to } 8 \text{ sq. ft.} =$$

$$\text{Lambing Pens: No. Ewes} \div 7 \text{ to } 10 \times 16 =$$

Hay Storage:

$$\frac{\text{No. Head} \times 20 \times \text{Months of Storage}}{\text{Depth of Storage}} =$$

Straw Storage:

$$\frac{\text{No. Head} \times 20 \times \text{Months of Storage}}{\text{Depth of Storage}} =$$

$$\text{Grain: No. Ewes} \times 2 + 3 \text{ (Max. Storage Depth)} =$$

$$\text{No. Feeder Lambs} \times 4 + 3 =$$

$$\text{No. Creep Fed Lambs} \times 1 + 3 =$$

$$\text{Supply Room: Length} \times \text{Width} =$$

$$\text{Other storage desired: Sq. Ft.} =$$

$$\text{TOTAL AREA NEEDED, Sq. Ft.} =$$

After you have decided on the total amount of space needed, determine the actual dimensions of the building (Fig. 4).

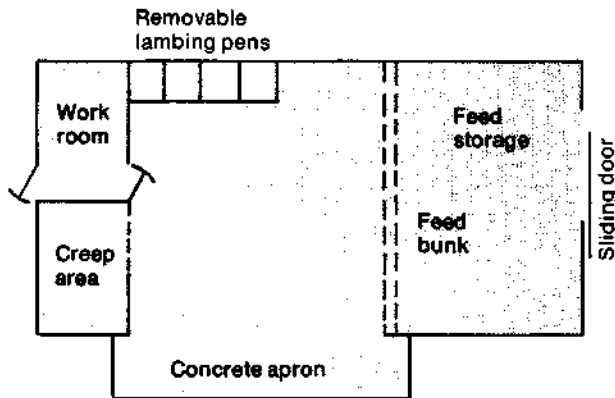

Fig. 4—Typical layout inside feeding.

Floors

The floor of a sheep building can be made of 2 to 4 inches of crushed limestone. Sand, gravel or compacted clay are the most common materials. (There are some concrete floors.) The floor should be well drained.

The supply room and feed storage floor areas should be concrete and well drained.

Feed Mangers

The sheep flock can be fed either indoors or outdoors. Properly sized mangers will help sheep to eat comfortably with a minimum of feed wastage. Several factors must be considered in designing a feeding system.

Each ewe will need 16 to 20 inches of bunk space to allow all ewes to eat at the same time. The hay bunk needs to be 8 to 10 inches per ewe if hay is available at all times.

The feeder lamb needs 9 to 12 inches of bunk space for all lambs to eat at once. This can be reduced to 3 to 4 inches if hay is available at all times.

You will need 1 to 1½ inches of creep feeder space for each lamb on creep feeding.

Bunks should be a maximum of 28 inches wide if the sheep feed from both sides (Fig. 5) and 14 inches if the sheep feed from only one side (Fig. 6). The

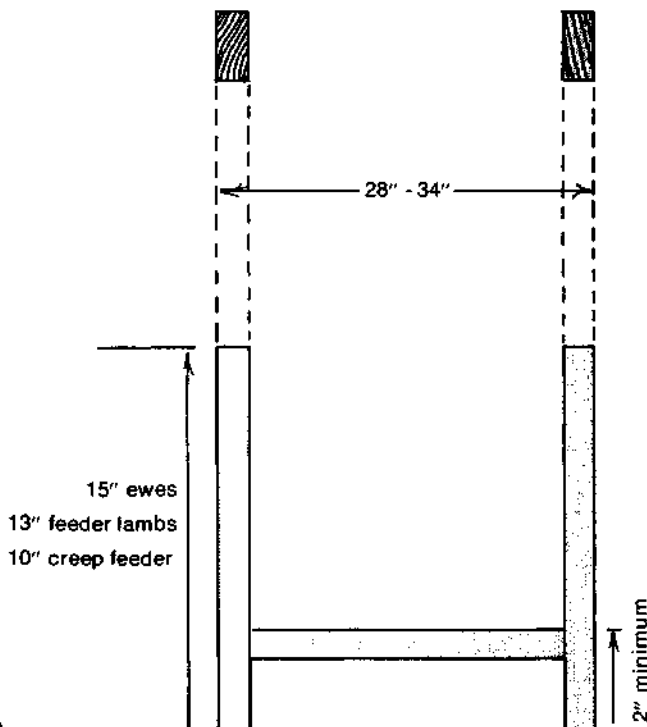

Fig. 5—Typical feeder for feeding on both sides.

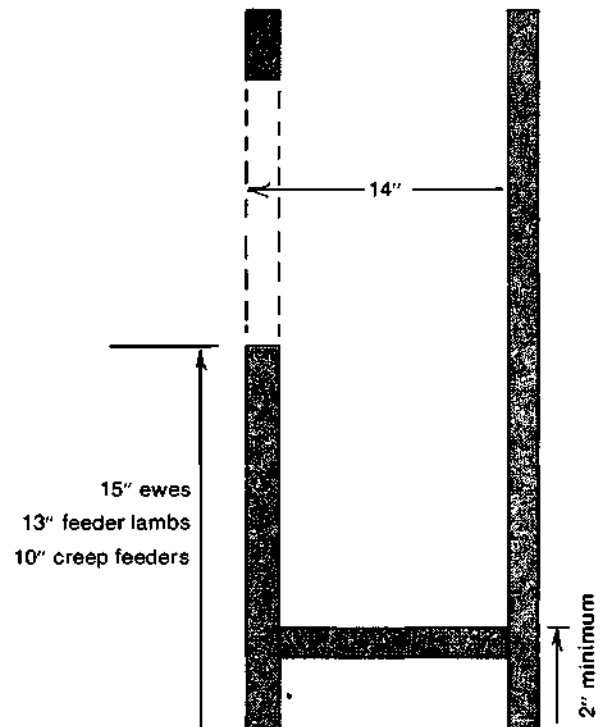

Fig. 6—Typical feeder for feeding on one side.

maximum heights the animal has to reach over is 15 inches for ewes, 13 inches for feeder lambs and 10 inches for creep feeding.

The bottom of the feed bunk varies in height depending on location and management. Inside feed bunks can be as low as 2 inches from the floor as long as manure is not allowed to build up alongside the bunk. Outside bunks should have bottoms a minimum of 6 inches from the ground, to allow for some buildup of snow, soil and manure. In no case should the buildup be such that the sheep has to eat at a level below its feet. Another consideration is that the higher the bottom of the feed bunk, the less feed storage and the more often the sheep have to be fed.

Hay can be stored in racks that extend to the ceiling if you have overhead hay storage. The hay racks would be filled from the upper level.

"The Sheep Handbook: Housing & Equipment" (MWPS-3), has details on many feeding bunks and racks. It is available from your local Extension office or the Agricultural Engineering Department, Michigan State University, East Lansing.

Ceiling Height

The ceiling height is determined by the method used to clean out the housing area. Hand cleaning will allow an 8-foot ceiling height. When a tractor is used, the ceiling height is determined by the height of the tractor and the operator. Allow about 1 foot more height than the tractor and operator need. This allows a degree of safety for the operator.

Water

You should plan on having water available in sheep housing at all times. Each ewe and lamb will consume up to 2½ gallons of water per day. A feeder lamb will use up to 1½ gallons per day.

An automatic bowl, electrically heated in cold weather, will handle 40-50 ewes and their lambs. Fifty to 75 feeder lambs can use one bowl. If you will be using a livestock tank for watering, you can figure on 15-25 ewes and lambs per foot of tank perimeter or 25-40 feeder lambs. Some form of heat should be supplied to keep the water in the tank from freezing.

Electricity

An adequate electrical service is an important part of your building. The service should be large enough to safely handle lighting, ventilation, spot space heating (if electrical) and shearing equipment. You may also want a water heater and a small refrigerator for medicine storage.

All lighting fixtures should be dust-proof. This reduces the fire hazard caused by dust buildup on

the bulbs. Locate lighting fixtures where they cannot be easily broken. A minimum of one light should be placed in the supply room and in the feed area.

Convenience outlets should be the covered outdoor type, so that dust and moisture cannot get into the outlet. Outlets should be located close to the lambing pens if heat lamps will be used for spot heat. There should be at least one outlet in the supply room.

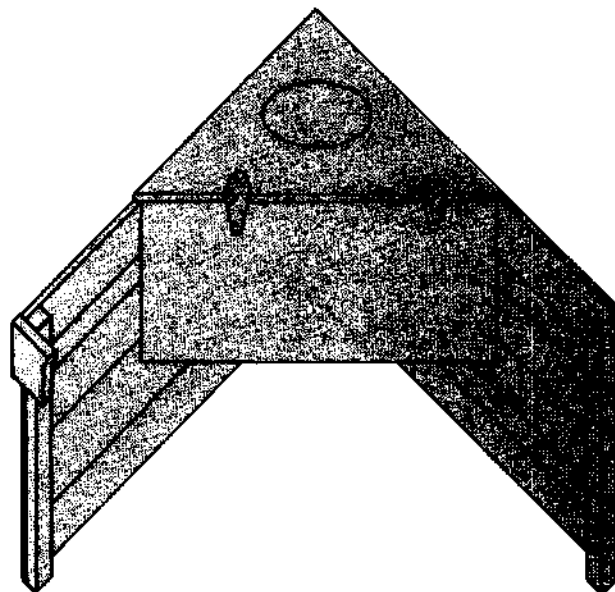

Fig. 7—Lamb hover Plan No. 872-C1-9.

Heat in Open or Cold Housing

Heat will be required during lambing season in open and cold housing. Normally spot heaters are used to supply heat in the area around the lamb. Heat lamp and radiant LP gas heaters are the most common heat sources.

Use supplemental heat with caution. Make sure the heat unit is fastened in such a way that it cannot drop into the bedding and cause a fire. The ewe should not be able to rub against it, for she could be burnt. The wiring must be installed according to the local electrical code.

It is a good idea to enclose one corner of the lambing pen with a plywood hover (Fig. 7). The lamb can get underneath to get the benefit of the heat. The heat lamp is protected from the ewe and from dropping into the bedding. Plan No. 872-C1-9 has the details on hover construction. See your county Cooperative Extension Service office to obtain a copy.

Heat is needed for a short period. Once the lamb is dried off and nursing satisfactorily, the heat can be discontinued. The continued use of supplemental heat may lead to pneumonia and other respiratory troubles.

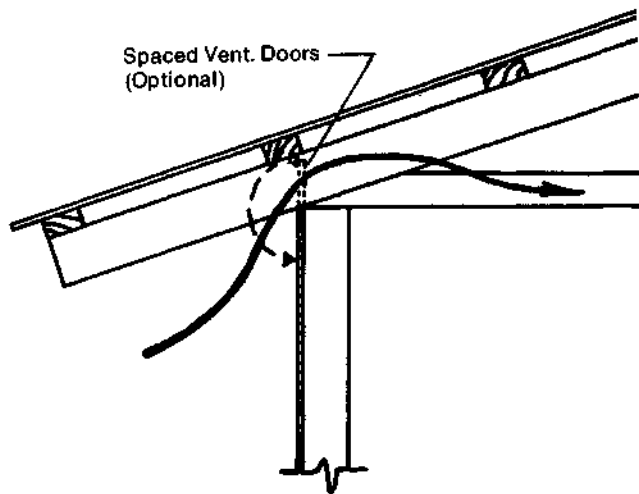

Fig. 8—Under-eave air inlet.

Ventilation

Buildings are ventilated to remove moisture produced by the sheep. If the moisture remains in the building, odors build up and condensation occurs on the windows, walls and ceiling. Excess moisture can lead to respiratory problems. It can also cause rotting of wood and wood products in the construction of the building.

The ventilation system must be properly designed to maintain the desired environment for sheep. The environment throughout the housing should be fairly uniform.

The ventilation system consists of three basic requirements:

- A way for fresh air to enter the building
- A means of moving the air through the building
- A way for the stale air to leave the building

If these three components are not properly designed, the system will not work.

Open Housing—uses natural air movement for ventilation. The open front should be to the south or east, away from prevailing winds.

Air inlets along the back are required to allow the fresh air to enter the building. The air inlets can be openings under the eaves (Fig. 8) or adjustable windows. In some cases a burlap bag is placed over the window opening in place of glass. This allows the air to move across the building and exhaust through the front. Insulation is recommended under the roof or in the ceiling to help prevent condensation.

Cold Housing—ventilation is similar to open housing. In most cases, air moves naturally through the building. Electric fans are occasionally used to aid in the air movement. There must be a place for air to enter the building and to exhaust. Air inlets can be openings under the eaves (Fig. 8) or adjustable windows. Air exhausts can be open doors and/or adjustable windows. As in the case of open housing, burlap bags can be used over window openings instead of glass. Insulation in the ceiling or under the roof is recommended to help prevent condensation.

Warm Housing—ventilation of warm housing is complex. You should use trained people in the design of a system for this type of housing. The building must be insulated, and vapor barriers are a must. Heat will be required to maintain temperature. In most cases, electric fans are used to provide air flow (Fig. 9). Fans on controls require no further attention once set. Windows or adjustable panels can be used to control airflow. Considerable attention is required by the owner in order to maintain temperature, as heat can be wasted by the constant airflow through the building.

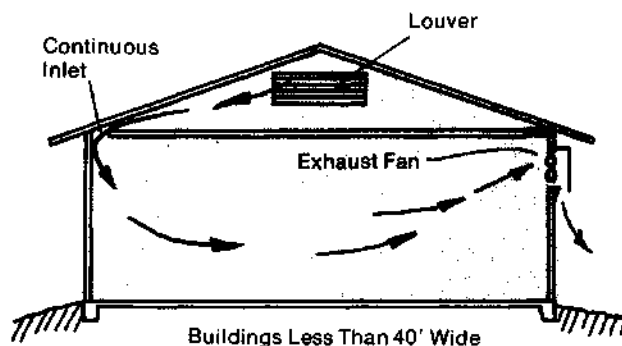

Fig. 9—Mechanical ventilation example.

At minimum, fans for winter ventilation have a capacity of 25 cubic feet per minute for each 1,000 pounds of sheep housing. Summer ventilation will require 100 cubic feet per minute.

The airflow of the selected fans should be rated at 1/8 inch static pressure. This gives the fan the ability to move air through the building.

The motor on the fan should be totally enclosed and protected by an overload protective device against burnout.

Shutters are needed on fans to prevent backdrafts. The fan should be shielded to protect people, animals, birds and the fan.

Insulating warm housing—In southern Michigan, the minimum recommended insulation "R" value is 14 for sidewalls and 23 for the ceiling (Fig. 10).

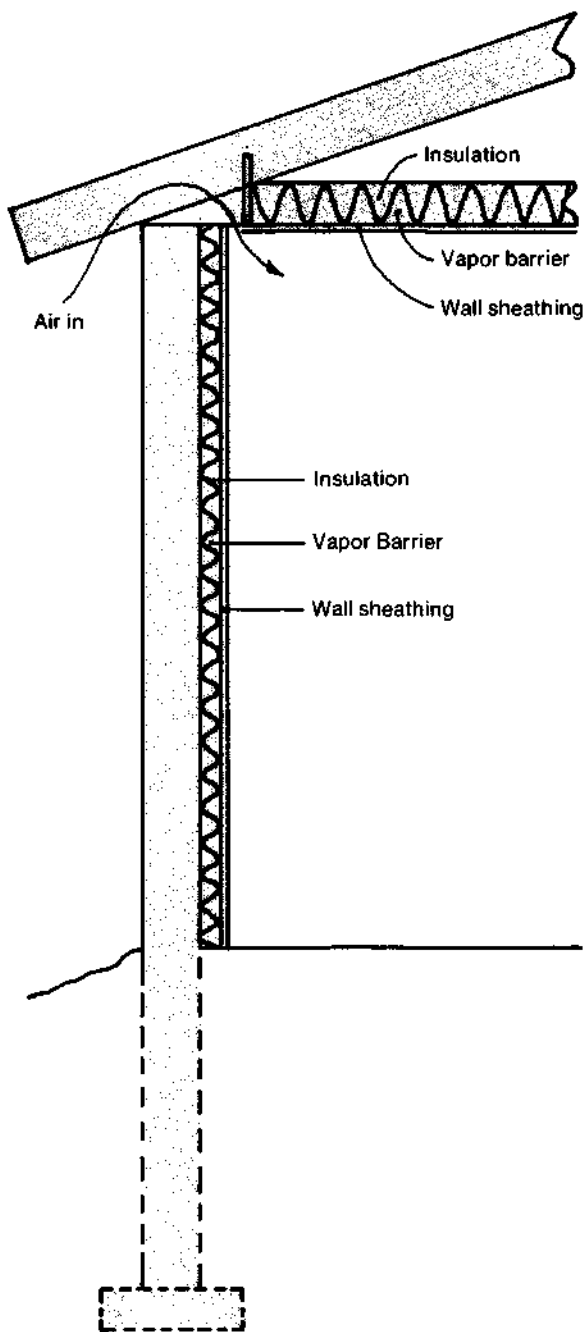

Fig. 10—Typical insulation placement.

Higher "R" values are desirable in northern Michigan. The "R" value is the measure of a material to resist the flow of heat through it. The higher the "R" value, the better the insulation material.

There are many types of insulating materials. Used correctly and in the proper amounts, most will properly insulate your sheep building.

Vapor barrier in warm housing—The vapor barrier is a vital part of the insulation and ventilation system. A vapor barrier slows or stops the movement of water vapor through the building walls and ceiling. Water vapor moves through walls and ceiling from the warm areas to the cold. Therefore, the vapor barrier belongs on the inside of the building walls and ceiling (Fig. 10).

As the water vapor moves through the wall, the dew point is reached and the vapor condenses in the wall. This lessens the insulation value of your insulation and can cause rotting of the wood in the wall.

The vapor barrier should be as tight as possible. It should be protected from mechanical damage by covering it with an interior surface.

The most common vapor barrier is 4 mil polyethylene plastic. Aluminum foil is also used. Many insulation batts have a vapor barrier.

MICHIGAN STATE UNIVERSITY



MSU is an Affirmative Action/Equal Opportunity Institution. Cooperative Extension Service programs are open to all without regard to race, color, national origin, or sex.

Issued in furtherance of cooperative extension work in agriculture and home economics, acts of May 8, and June 30, 1914, in cooperation with the U.S. Department of Agriculture. Gordon E. Guyer, Director, Cooperative Extension Service, Michigan State University, E. Lansing, MI 48824.

This information is for educational purposes only. Reference to commercial products or trade names does not imply endorsement by the Cooperative Extension Service or bias against those not mentioned. This bulletin becomes public property upon publication and may be reprinted verbatim as a separate or within another publication with credit to MSU. Reprinting cannot be used to endorse or advertise a commercial product or company.

Price 50 cents.

1P-6-B1-2.5M-DG-UP.

Michigan State University Printing