

ENERGY FACTS

Cooperative Extension Service
Michigan State University

Energy Fact Sheet No. 2

Extension Bulletin E-1112

January 1978

Wind Power

By Truman C. Surbrook

Extension Specialist, and Jeffrey E. Friedle, Graduate Assistant, Department of Agricultural Engineering

Using the wind for power is not a new idea. Drawings 5,000 years old depict boats on the Nile River using the wind. The first windmills, which were used for grinding grain, appeared in Persia in about 200-400 B.C.

Returning Crusaders introduced windpower to Europe in the 13th century. By the 14th century the Dutch had advanced the technology and were using windpower to drain portions of river deltas.

In the United States, windpower was used for pumping water from the early 1800s until about 20 years ago. From 1927 to the mid-1950s, wind-driven generators produced up to 3 kilowatts (kw) of power for basic electric needs of rural homes and farmsteads.

The decrease in the use of wind devices was the result of two factors:

1. Availability of central station power on demand which was dependable and inexpensive.
2. Opportunity to have power available with little or no initial investment and no maintenance problems.

Wind Characteristics

The major factors responsible for power output from a particular wind machine are area and wind speed. Of these two factors, wind speed has the greatest effect. A minimum average wind speed of 7 miles per hour is required to operate a windmill. Doubling the area will double the power output, but doubling the wind speed will result in a power output eight times the original output. It is important, then, to locate the wind machine in such a way as to take best advantage of the prevailing wind.

Wind speed is affected by topography (hills and valleys) and surface roughness (buildings and trees). Surface roughness will naturally tend to reduce wind speed near the ground. Wind speed will continue to

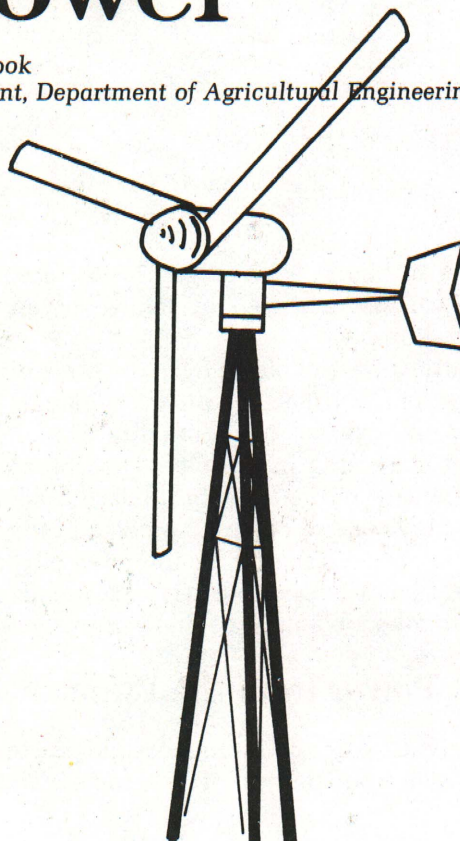

FIGURE 1. High speed propeller-driven wind generator.

increase at higher elevations. This effect is illustrated in Figure 2. Construction sites for wind machines should be chosen to avoid the "shadows" of obstacles that will reduce wind speed.

A cost comparison should be made between increasing the rotor area versus increasing the tower height to maximize the power output of the wind machine.

Certain topographical features can augment wind speed. The speed of the wind will increase where the wind is funneled into a valley. Speed will also be slightly higher near the ground at the top of a hill where air flow is over a smooth hill. These effects are

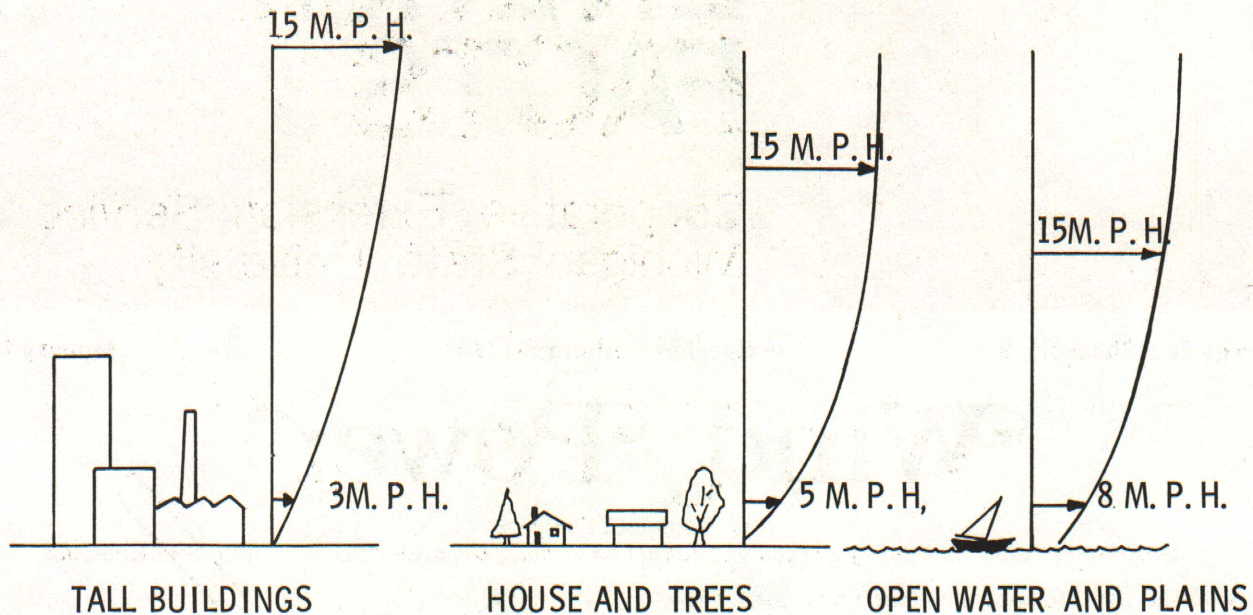

FIGURE 2. Surface roughness by tall objects reduces wind speed near the ground.

illustrated in Figure 3. Average power from a wind machine can be increased by taking advantage of these situations.

Normally, the wind blows from the same direction 65 percent of the time. The other 35 percent of the time the wind "gusts," changing direction 15-70 degrees and increasing in velocity. These gusts occur only 35 percent of the time, but due to their higher velocity, they contain about 75 percent of the power in the wind. Depending on the intended purpose for the power, it may be possible to choose a rotor design which can take advantage of these power gusts.

Power from the Wind

The theoretical or maximum possible power in the wind depends upon the area of the wind collector and

the cube of the wind speed. The following formula expresses this relationship in the form of watts.

$$\text{Power}_T = 0.00502 \times \text{Area} \times (\text{Wind Speed})^3$$

where: Power_T = theoretical wind power in watts
 Area = useful area of rotor in square feet
 Wind speed = average wind speed in miles per hour

Unfortunately, it is not possible to extract all of the power in the wind. An ideal wind machine can obtain about 59 percent of the theoretical windpower. But real wind machines operate with a much lower efficiency. Actual power efficiency is dependent upon wind machine design. There are four types of wind machines in common use and their approximate efficiencies are given in Table 1. Actual efficiency varies as a result of changes in the ratio of the speed of

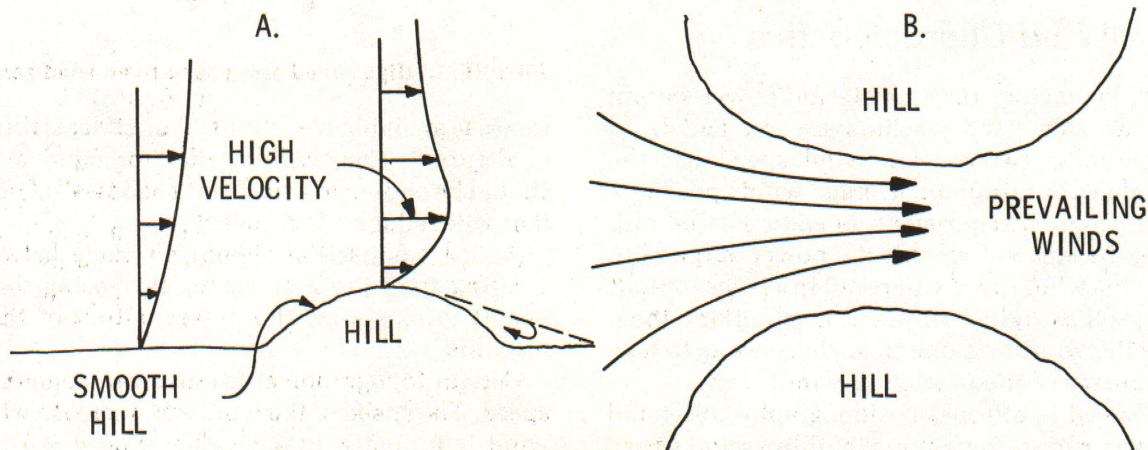

FIGURE 3. (a) Wind speed increases as wind flows over a smooth hill. (b) Wind speed may be higher in a valley between two hills.

Table 1. Approximate efficiency for various wind machines. (Rotor types are described later.)

Type	Efficiency
High-Speed Propeller	45%
Darrieus Rotor	32%
Multiblade Turbine	30%
Savonius Rotor	16%
Modified	18%

the tip of the propeller to the wind speed. But for power estimation purposes, the efficiencies of Table 1 are sufficient.

There is a further reduction involved in the process of converting this shaft power to electrical power. Power is lost in gearboxes or pulley drives, the alternator or generator and any other power-conversion equipment. This conversion efficiency can vary from 50 to 80 percent. For the purpose of power estimation, 65 percent will be used in the formula.

$$\text{Efficiency} = \text{Efficiency (Rotor)} \times \text{Efficiency (Conversion)}$$

Therefore, the approximate electrical power in watts which can be expected from a wind machine can be determined by the following formula:

$$\text{Power} = 0.00502 \times \text{Area} \times (\text{Wind Speed})^3 \times \text{Efficiency}$$

The area in the formula is the useful area of the rotor perpendicular to the direction of the wind. For the high-speed propeller and the multiblade turbine types the area is easy to determine.

$$\begin{aligned} \text{Area (propeller)} &= \frac{\pi}{4} \times (\text{diameter})^2 \\ &= 0.785 \times (\text{diameter})^2 \end{aligned}$$

For the Savonius type only about half the area swept by the turning rotor is useful. (See Figure 4.)

$$\text{Area (Savonius)} = \text{Radius} \times \text{Height}$$

In the case of the Darrieus rotor, the actual area perpendicular to the direction of the wind will have to be determined.

Example: A 6-foot diameter high-speed propeller wind machine is in an area where the wind speed averages 15 miles per hour.

$$\text{Area} = 0.785 \times (\text{diameter})^2 = 0.785 \times (6)^2 = 28.3 \text{ ft}^2$$

$$\text{Wind speed} = 15 \text{ miles per hour}$$

$$\begin{aligned} \text{Efficiency} &= \text{Efficiency (Rotor)} \times \text{Efficiency (Conversion)} \\ &= 0.45 \times 0.65 = 0.29 \end{aligned}$$

$$\text{Power} = 0.00502 \times 28.3 \times (15)^3 \times 0.29 = 139 \text{ watts}$$

Realistic total system efficiencies are between 10 and 30 percent. Therefore, at best, 30 percent of the theoretical wind energy can be turned into electrical energy.

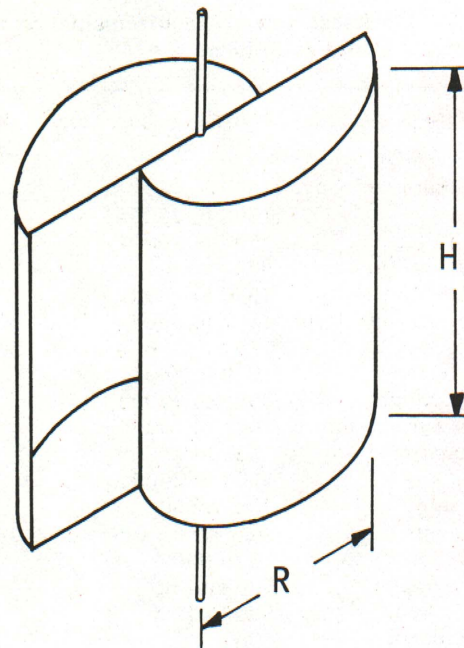

FIGURE 4. The useful wind collecting area of a Savonius rotor is estimated to be the radius times the height.

Based on a total system efficiency of 30 percent, Table 2 gives the actual power to be expected from wind machines of various rotor diameters.

Table 2. Available power (watts) from the wind assuming a system efficiency of 30 percent.

Rotor Diameter (ft)	Average Wind Speed (miles per hour)				
	5	10	15	20	25
4	2	19	64	152	296
6	5	43	144	341	665
8	10	76	256	605	1183
10	15	119	399	947	1848
12	21	170	575	1363	2661
14	30	232	782	1855	3623
16	38	307	1022	2423	4731
18	48	383	1293	3066	5988
20	59	473	1597	3785	7393

Commercial wind generator sets have a power output rating generally based upon a wind speed of 25 to 30 miles per hour. Therefore, power output at lower wind speeds will be less than the rated output.

To estimate the size generator needed to power electrical equipment in the home, the wattage of electrical equipment to be operated at any particular time must be determined. Table 3 can be used to estimate the wattage required. A type of wind machine must be selected, and the size rotor calculated as described earlier.

Table 3. Electrical power requirements of household appliances and equipment.

Appliance	Watts	Horsepower
Refrigerator	1500‡	1/4
Freezer	1500 to 2300‡	1/4 to 1/2
Water pump	2300 to 7500‡	1/2 to 2
Furnace oil burner	860‡	1/6
Furnace blower	1500 to 2300‡	1/4 to 1/2
Electric clothes dryer	1500 to 5000	and 1/6 to 1/4
Clothes washer	1500 to 2300‡	1/4 to 1/2
Water heater	1000 to 6000	
Electric range	3000 to 12000	
Small surface unit	1000 to 1400	
Large surface unit	1500 to 2400	
Oven	2500 to 4000	
Television	200 to 600	
Dishwasher	(may have booster heater) 1/6	
Electric fan	75 to 300	
Electric heater	500 and up	
Electric iron	500 to 1200	
Coffee maker	1000	
Mixer	100 to 175	
Electric skillet	1200	
Toaster	1100	
Incandescent lamp	(wattage on lamp)	
Fluorescent lamp*	(wattage on lamp × 1.2)	
Mercury yard lamp*	200, 300 or 450	

*The fixture draws more power than the lamp wattage because of the ballast.

‡This is the power required to start the motor. The motor will draw only one-fourth this amount of power once it obtains full operating speed.

Rotor Types

Rotors of wind machines can be classified according to the orientation of the axis of rotation to the direction of the wind. Rotors with their axis parallel to the wind stream are called horizontal rotors. Some means of keeping the rotor faced into the wind is needed. The gyroscopic effect of the rotor will make tracking slow, and quick changes of wind direction gusts will not be utilized.

Vertical axis rotors have their axis perpendicular to the earth and to the wind stream. These rotors accept wind from any direction, thus better utilizing the extra power in the gusts.

Rotors can be further classified as "drag" or "lift" type. Drag type rotors have lower efficiencies, but they develop higher torque (turning power) at low speed. Lift type rotors produce power from drag forces plus force from lift due to the airfoil shape of the blade. Lift type rotors generally operate at higher efficiencies. Little low-speed torque is a limitation, but the lift type develops more power per unit area of rotor.

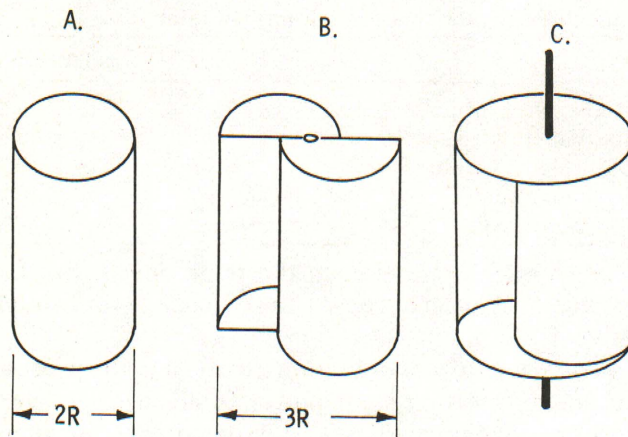

FIGURE 5. Savonius rotor can be constructed from (a) 55 gal. drum, cut in half and welded in (b) an offset manner. Finished rotor (c) with end caps installed.

Savonius Rotor

The Savonius rotor is a vertical axis, drag type wind machine. This slow-turning rotor has a high starting torque and is well suited for pumping water. The slow speed means balancing the rotor is not critical. A major advantage of this rotor is cost of construction. Cylinders, such as 55-gallon drums, are split and offset as shown in Figure 5. End caps are added to complete the rotor. One disadvantage of using steel drums is the weight of the rotor.

Because of low cost, several rotors can be stacked to increase surface area. With this arrangement, enough power can be derived from the wind to operate a small generator. The original Savonius rotor had a maximum efficiency of 15 percent, but with the modified design shown in Figure 6, maximum efficiency was increased to 18 percent.

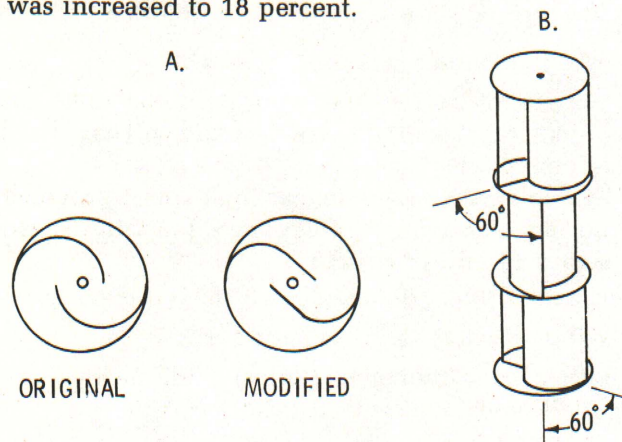

FIGURE 6. (a) The modified Savonius rotor has a higher efficiency than the original design. (b) Savonius rotors can be stacked one on top of the other to get more area facing the wind. Each rotor should be rotated 60° from the one below.

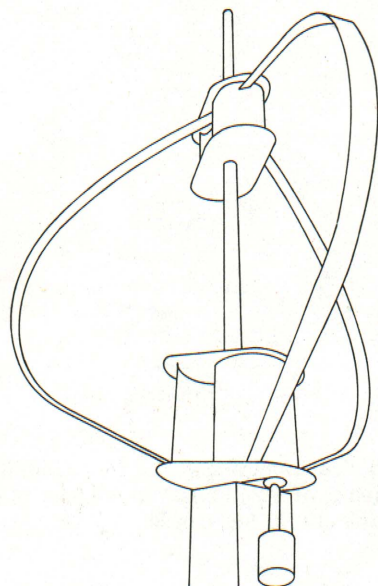

FIGURE 7. The three blade Darrieus rotor is often used to power wind generators. The small Savonius rotors at the top and bottom are added to make the Darrieus self-starting.

Darrieus Rotor

The Darrieus rotor is a vertical axis, lift type wind machine. The rotor has two or three blades with an airfoil cross section. It has a maximum efficiency of 38 percent, but due to very low starting torque, it is not self-starting. A Savonius rotor could be added, as shown in Figure 7, to make it self-starting. It is a reasonably high-speed rotor and is suitable for powering a generator.

Multiblade Turbine

The multiblade turbine (Stewart Mill) is the familiar water pumping wind machine (Figure 8). The rotor generally has from 15 to 40 blades on a horizontal axis. This drag type rotor operates at a relatively low speed, thus balancing of the rotor is not critical. Because of high starting torque, it is very well suited for pumping water.

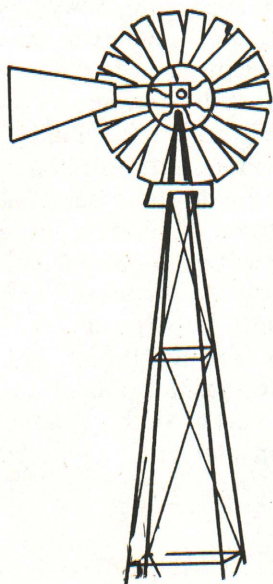

FIGURE 8. The multiblade turbine is ideal for pumping water.

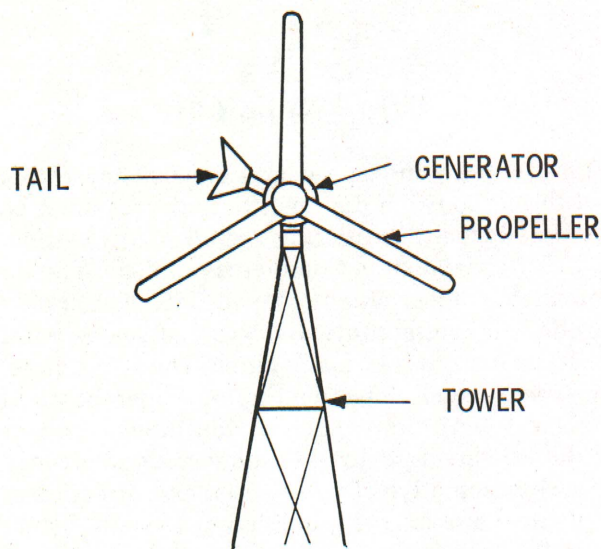

FIGURE 9. The three-bladed high speed propeller is most popular for powering wind generators.

High-Speed Propeller

The high-speed propeller is the lift type and has two or three airfoil blades (Figure 9). A three-blade propeller is generally easier to balance. Maximum efficiency for this type is 47 percent, but in spite of low starting torque it is well suited for generating electricity.

The high-speed propeller and the multiblade turbine both need some means of keeping the rotor faced into the wind. A tail vane or rudder is often used. With all four types, some means must be provided for braking the rotor or turning it out of the wind. This is necessary to prevent damage to the rotor or other system components when the wind speed becomes excessive.

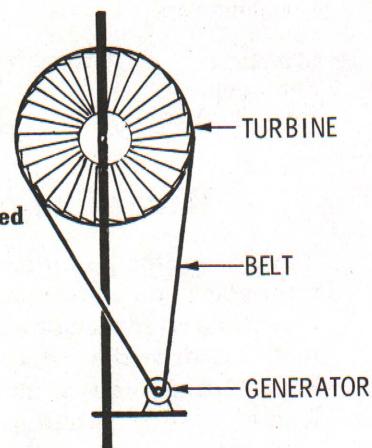

FIGURE 10. The super-speed turbine drives the generator with a belt.

Super-Speed Turbine (SST)

This type looks similar to the multiblade turbine except the SST has airfoil blades (Figure 10). Instead of using a gear box at the shaft, the SST has a belt which travels around the outside of the rotor and drives the generator directly. This type has been tested at Oklahoma State University.

Wind Speed

The average wind speed and consistency of the wind throughout the day, month and year must be determined when considering a wind energy system. The U.S. Department of Commerce publishes annual summaries of local climatological data. These data give the average monthly and average yearly wind speed and direction in many cities. The wind, however, is very much dependent upon topography and other local conditions, such as buildings, trees or large lakes. Therefore, local weather station data may not be representative of wind speed and direction at the planned site for the wind energy system. Before any major investment is made, a thorough study of local wind conditions is necessary.

For meteorological data, specify the location from Table 4 and the year. Ask for "Local Climatological Data, Annual Summary with Comparative Data." Write to: National Climatic Center, Federal Building, Asheville, NC 28801, and mark on the envelope "Attention Publications."

Table 4. Average wind speed for various locations in Michigan based upon 1974 weather data. These wind speeds were determined at 20 feet above the ground.

LOCATION	AVERAGE WIND SPEED (MILES PER HOUR)			
	January	April	July	October
Alpena	8.9	9.7	7.5	7.5
Detroit	11.1	9.7	8.1	6.1
Detroit Metro	13.9	11.9	10.6	7.8
Flint	8.9	9.2	8.9	6.1
Grand Rapids	10.3	11.7	8.6	8.3
Houghton Lake	7.2	8.1	7.0	6.4
Lansing	12.5	10.6	10.0	7.2
Marquette	10.0	8.3	13.9	10.6
Muskegon	8.1	8.9	6.4	7.0
Sault Ste. Marie	13.0	8.1	5.5	8.1

Water Pumping Systems

A system for pumping water would consist of a rotor placed on a tower and a pump. The rotary motion of the wind machine is changed to reciprocating motion to drive the piston of the pump. A rotor with a high starting torque is needed to overcome the large load of a piston pump.

Figure 11 shows maximum pumping rate with average wind 15 to 18 m.p.h. and different diameter rotors. Pumping rate will vary as shown in Figure 12 due to the change in velocity. A maximum rate is achieved because the rotor is designed to turn itself out of the wind as a safety factor when winds become excessive. A water storage tank must also be provided to hold water during periods when there is little or no wind.

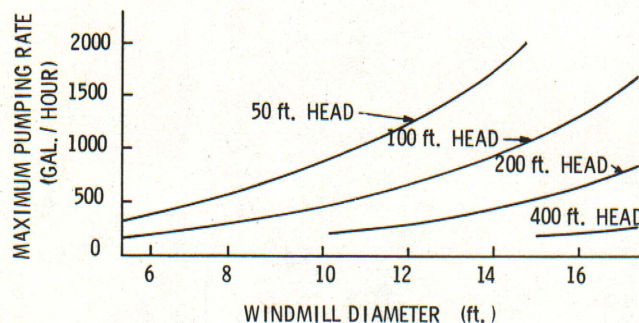

FIGURE 11. Typical pumping rates for windmills with an overall efficiency of 10%. Wind speed was 15 mph for small mills and 18 mph for large mills.

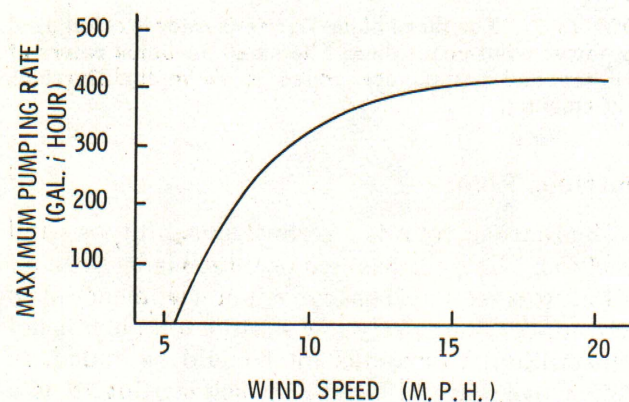

FIGURE 12. Typical output of a 10-ft.-diameter windmill and 100-ft.-head of various wind speeds.

Wind-Generating Systems

The major drawback to using wind-generated electricity is that there is not a constant supply of electrical power available when it is needed. If wind-generated electricity is to be used for domestic purposes, some adjustments in home energy use patterns will be necessary. Electrical energy-using activities will have to be rescheduled to some extent to take advantage of the wind. Another problem is the pattern of energy usage. Because utility power has always been available at any time in sufficient quantity, electrical energy usage in the home is concentrated in short time periods due to eating habits and personal convenience. These peak periods of energy usage generally occur in the morning between 7 and 9 a.m. and in late afternoon and early evening between 4 and 8 p.m. What this means is that a large generator is needed to supply electricity during these peak periods, but during the slack periods the generator is running mostly idle. In order to get by with a smaller generator and thus a lower investment, it will be

necessary to adjust home energy usage patterns to lower peak electrical demand.

Most people aren't willing to put up with the inconvenience of having electricity only when the wind blows. Therefore, a more practical approach is to use wind power to supplement normal utility power. The double throw transfer switch is the only arrangement approved today by most electrical power suppliers for transfer between normal utility power and wind generator. This is the same type of transfer switch required for emergency standby generators. With this system, the home can be manually switched from utility power to the wind generator when there is sufficient wind to handle the home electrical load. Check with your local electrical supplier concerning the connection of a wind generator to your home wiring system.

Most electrical appliances require alternating current with a constant voltage and frequency identical to utility power in order to prevent damage to the equipment. The voltage must be either 115 or 230, and the frequency must be 60 hertz. As the wind speed changes, the output voltage and frequency of the wind generator will change. There are several ways to solve this problem.

One method of voltage and frequency regulation is to use a direct current generator to charge batteries. An inverter is used to produce 115- or 230-volt, 60-hertz alternating current from the batteries even if the wind is not blowing. Only deep discharge or deep cycle batteries will withstand the extremes of charging and discharging over a long period of time. Regular auto or truck batteries will develop plate decomposition or buckling under deep discharge. Batteries must be stored in a warm area for maximum effectiveness. A half-charged battery will freeze at -6°F , and a completely discharged battery will freeze at $+18^{\circ}\text{F}$. The disadvantage of this system is the high cost and maintenance of the batteries.

A more desirable approach is to use an inverter capable of producing the 115- or 230-volt, 60-hertz alternating current directly from the output of the direct current generator powered by the wind machine.

A third approach is to use the output of the wind generator directly to perform a task not requiring constant voltage or frequency. One such task is heating water. A 30-gallon electric water heater can be installed ahead of the main water heater as a preheater. The 30-gallon water heater is then connected directly to the wind generator. When there is wind, water will be partially heated by the wind generator, thus reducing the energy demand of the main water heater. (See Figure 13.)

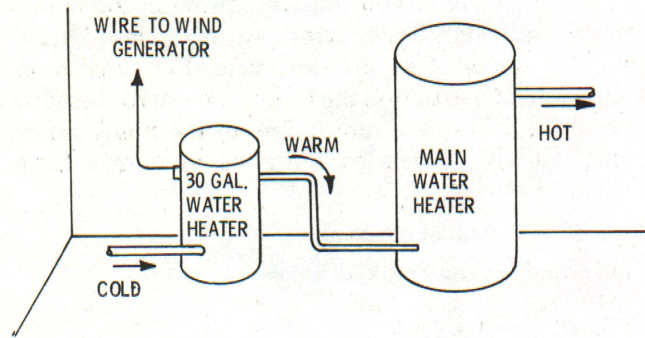

FIGURE 13. Wind generator used to preheat water.

Equipment Needed

There are a number of components required for a complete wind generator system:

1. Rotor, preferably a 3-blade, high-speed propeller.
2. Alternator.
3. Gearbox, pulley drive or direct drive to connect the rotor to the alternator at the proper revolutions per minute.
4. A tower for mounting the rotor and equipment high enough to take advantage of higher wind speeds above the ground.
5. A brake to stop the machine for repairs.
6. Controls for voltage regulation, or an inverter.
7. Rotor speed control to prevent overspeeding in high winds.

Batteries can be added to store excess electricity or to make electrical power available when there is no wind. An inverter is then required to convert the direct current of the batteries to alternating current for household appliances. But, generally, most people do not want the added expense and maintenance of storage batteries, so instead they try to use the electricity directly. Approximate costs for some components are listed in Table 5.

Table 5. Costs of some wind-generation components based on 1976 prices.

Item	Approximate Cost (Dollars)
Steel tower, per foot	20 - 22
Storage batteries	
Use only deep discharge or deep cycle batteries	95 - 125
Inverter, 12 volt DC to 115 volt AC	
200 watt, light duty	40 - 60
1000 watt, heavy duty	350 - 400
Standby generator, heavy duty	
115 volt AC	600 - 1000
1500 - 3000 watts	

Further Information

The purpose of this bulletin is to provide you with a general understanding of wind power and familiarize you with some of its possible uses. For details on design and construction the following references will be helpful. These are only a few of the many references available. Libraries and bookstores may have these and others.

For a good technical overview:

Wind Machines, by Frank Eldridge
Mitre Corp.
Westgate Research Park
McLean, VA 22101

Nontechnical language and good drawings:

Wind and Wind Spinners, by Michael A. Hackleman
Earthmind
P.O. Box 276
Acton, CA 93510

Constructing a Savonius rotor:

"How to Construct a Cheap Wind Machine
for Pumping Water"
Do-it-yourself leaflet No. 5
Brace Research Institute
MacDonald College of McGill University
Ste. Anne DeBellevue
Quebec, Canada

General description and ideas:

Handbook of Homemade Power
Mother Earth News
Henderson, NC 27536

Acknowledgements

The Michigan Committee on Rural Electrification provided financial and technical support for development of this bulletin. The following individuals also provided technical assistance:

Ray C. Alexander, Consumers Power Company

Erwin J. Raven, The Detroit Edison Company

Claybourne Mitchell, Jr., The Detroit Edison
Company

Howard J. Doss, Agricultural Engineering
Department, MSU

John B. Gerrish, Agricultural Engineering
Department MSU

Bill A. Stout, Agricultural Engineering
Department, MSU

This information is for educational purposes only. Reference to commercial products or trade names does not imply discrimination or indorsement by the Cooperative Extension Service. Cooperative Extension Service Programs are open to all without regard to race, color, or national origin. Issued in furtherance of cooperative extension work in agriculture and home economics, acts of May 8, and June 30, 1914, in cooperation with the U.S. Department of Agriculture. Gordon E. Guyer, Director, Cooperative Extension Service, Michigan State University, E. Lansing, MI 48824

1P-10M-1:78-UP, Price 10 cents, Single copy free to Michigan residents

Michigan State University Printing